

CITY OF SOLANA BEACH
SOLANA BEACH CITY COUNCIL, SUCCESSOR AGENCY TO THE REDEVELOPMENT AGENCY,
PUBLIC FINANCING AUTHORITY, & HOUSING AUTHORITY



AGENDA

Joint REGULAR Meeting
Wednesday, April 27, 2022 * 6:00 p.m.

City Hall / Council Chambers, 635 S. Highway 101, Solana Beach, California

- City Council meetings are video recorded and archived as a permanent record. The [video](#) recording captures the complete proceedings of the meeting and is available for viewing on the City's website.
- Posted Reports & Supplemental Docs contain records up to the cut off time prior to meetings for processing new submittals. Complete records containing meeting handouts, PowerPoints, etc. can be obtained through a [Records Request](#).

PUBLIC MEETING ACCESS

The Regular Meetings of the City Council are scheduled for the 2nd and 4th Wednesdays and are broadcast live. The video taping of meetings are maintained as a permanent record and contain a detailed account of the proceedings. Council meeting tapings are archived and available for viewing on the City's [Public Meetings](#) webpage.

WATCH THE MEETING

- Live web-streaming: Meetings web-stream live on the City's website on the City's [Public Meetings](#) webpage. Find the large Live Meeting button.
- Live Broadcast on Local Govt. Channel: Meetings are broadcast live on Cox Communications - Channel 19 / Spectrum (Time Warner)-Channel 24 / AT&T U-verse Channel 99.
- Archived videos online: The video taping of meetings are maintained as a permanent record and contain a detailed account of the proceedings. Council meeting tapings are archived and available for viewing on the City's [Public Meetings](#) webpage.

AGENDA MATERIALS

A full City Council agenda packet including relative supporting documentation is available at City Hall, the Solana Beach Branch [Library](#) (157 Stevens Ave.), La Colonia Community Ctr., and online www.cityofsolanabeach.org. Agendas are posted at least 72 hours prior to regular meetings and at least 24 hours prior to special meetings. Writings and documents regarding an agenda of an open session meeting, [received](#) after the official posting, and distributed to the Council for consideration, will be made available for public viewing at the same time. In addition, items received at least 1 hour 30 minutes prior to the meeting time will be uploaded online with the agenda posting. Materials submitted for consideration should be forwarded to the [City Clerk's department](#) 858-720-2400. The designated location for viewing of hard copies is the City Clerk's office at City Hall during normal business hours.

PUBLIC COMMENTS

Written correspondence (supplemental items) regarding an agenda item at an open session meeting should be submitted to the City Clerk's Office at clerkoffice@cosb.org with a) Subject line to include the meeting date b) Include the Agenda Item # as listed on the Agenda.

- Correspondence received after the official posting of the agenda, but two hours prior to the meeting start time, on the meeting day, will be distributed to Council and made available online along with the agenda posting. All submittals received before the start of the meeting will be made part of the record.
- Written submittals will be added to the record and not read out loud.

And/Or

Verbal Comment Participation:

Please submit a speaker slip to the City Clerk prior to the meeting, or the announcement of the Section/Item, to provide public comment. Allotted times for speaking are outlined on the speaker's slip for each agenda section: Oral Communications, Consent, Public Hearings and Staff Reports.

Public speakers have 3 minutes each to speak on each topic. Time may be donated by another individual who is present at the meeting to allow an individual up to 6 minutes to speak. Group: Time may be donated

by two individuals who are present at the meeting allowing an individual up to 10 minutes to speak. Group Hearings: For public hearings only, time may be donated by two individuals who are present at the meeting allowing an individual up to 15 minutes to speak.

SPECIAL ASSISTANCE NEEDED

In compliance with the Americans with Disabilities Act of 1990, persons with a disability may request an agenda in appropriate alternative formats as required by Section 202. Any person with a disability who requires a modification or accommodation in order to participate in a meeting should direct such request to the [City Clerk's office](#) (858) 720-2400 at least 72 hours prior to the meeting.

As a courtesy to all meeting attendees, please set cellular phones and pagers to silent mode and engage in conversations outside the Council Chambers.

<u>CITY COUNCILMEMBERS</u>		
Lesa Heebner, Mayor		
Kelly Harless, Deputy Mayor		David A. Zito, Councilmember
Jewel Edson, Councilmember		Kristi Becker, Councilmember

Gregory Wade
City Manager

Johanna Canlas
City Attorney

Angela Ivey
City Clerk

SPEAKERS:

Please submit your speaker slip to the City Clerk prior to the meeting or the announcement of the Item. Allotted times for speaking are outlined on the speaker's slip for Oral Communications, Consent, Public Hearings and Staff Reports.

READING OF ORDINANCES AND RESOLUTIONS:

Pursuant to [Solana Beach Municipal Code](#) Section 2.04.460, at the time of introduction or adoption of an ordinance or adoption of a resolution, the same shall not be read in full unless after the reading of the title, further reading is requested by a member of the Council. If any Councilmember so requests, the ordinance or resolution shall be read in full. In the absence of such a request, this section shall constitute a waiver by the council of such reading.

CALL TO ORDER AND ROLL CALL:

CLOSED SESSION REPORT:

FLAG SALUTE:

APPROVAL OF AGENDA:

PROCLAMATIONS/CERTIFICATES: *Ceremonial*

None at the posting of this agenda

PRESENTATIONS: *Ceremonial items that do not contain in-depth discussion and no action/direction.*

None at the posting of this agenda

ORAL COMMUNICATIONS:

Comments relating to items on this evening's agenda are taken at the time the items are heard. This portion of the agenda provides an opportunity for members of the public to address the City Council on items relating to City business and not appearing on today's agenda by submitting a speaker slip (located on the back table) to the City Clerk. Pursuant to the Brown Act, no action shall be taken by the City Council on public comment items. Council may refer items to the City Manager for placement on a future agenda. The maximum time allotted for each presentation is THREE MINUTES. No donations of time are permitted (SBMC 2.04.190). Please be aware of the timer light on the Council Dais.

COUNCIL COMMUNITY ANNOUNCEMENTS / COMMENTARY:

An opportunity for City Council to make brief announcements or report on their activities. These items are not agendized for official City business with no action or substantive discussion.

A. CONSENT CALENDAR: (Action Items) (A.1. - A.5.)

Items listed on the Consent Calendar are to be acted in a single action of the City Council unless pulled for discussion. Any member of the public may address the City Council on an item of concern by submitting to the City Clerk a speaker slip (located on the back table) before the Consent Calendar is addressed. Those items removed from the Consent Calendar by a member of the Council will be trailed to the end of the agenda, while Consent Calendar items removed by the public will be heard immediately after approval of the Consent Calendar to hear the public speaker.

All speakers should refer to the public comment section at the beginning of the agenda for details. Please be aware of the timer light on the Council Dais.

A.1. Minutes of the City Council.

Recommendation: That the City Council

1. Approve the Minutes of the City Council meetings held February 9, 2022 and March 2, 2022.

[Item A.1. Report \(click here\)](#)

Posted Reports & Supplemental Docs contain records up to the cut off time, prior to the start of the meeting, for processing new submittals. The final official record containing handouts, PowerPoints, etc. can be obtained through a Records Request to the City Clerk's Office.

A.2. Register Of Demands. (File 0300-30)

Recommendation: That the City Council

1. Ratify the list of demands for March 26, 2022 – April 15, 2022.

[Item A.2. Report \(click here\)](#)

Posted Reports & Supplemental Docs contain records up to the cut off time, prior to the start of the meeting, for processing new submittals. The final official record containing handouts, PowerPoints, etc. can be obtained through a Records Request to the City Clerk's Office.

A.3. General Fund Adopted Budget for Fiscal Year 2021/2022 Changes. (File 0330-30)

Recommendation: That the City Council

1. Receive the report listing changes made to the Fiscal Year 2021/2022 General Fund Adopted Budget.

[Item A.3. Report \(click here\)](#)

Posted Reports & Supplemental Docs contain records up to the cut off time, prior to the start of the meeting, for processing new submittals. The final official record containing handouts, PowerPoints, etc. can be obtained through a Records Request to the City Clerk's Office.

A.4. Quarterly Investment Report. (File 0350-44)

Recommendation: That the City Council

1. Accepts and files the Cash and Investment Report for the quarter ended March 31, 2022.

[Item A.4. Report \(click here\)](#)

Posted Reports & Supplemental Docs contain records up to the cut off time, prior to the start of the meeting, for processing new submittals. The final official record containing handouts, PowerPoints, etc. can be obtained through a Records Request to the City Clerk's Office.

A.5. Solid Waste Rate Review - Proposition 218 Notification. (File 1030-15)

Recommendation: That the City Council

1. Adopt **Resolution 2022-037** setting the Solid Waste Rate Review Public Hearing protest vote for June 22, 2022.

[Item A.5. Report \(click here\)](#)

Posted Reports & Supplemental Docs contain records up to the cut off time, prior to the start of the meeting, for processing new submittals. The final official record containing handouts, PowerPoints, etc. can be obtained through a Records Request to the City Clerk's Office.

NOTE: The City Council shall not begin a new agenda item after 10:30 p.m. unless approved by a unanimous vote of all members present. (SBMC 2.04.070)

B. PUBLIC HEARINGS: (B.1)

This portion of the agenda provides citizens an opportunity to express their views on a specific issue as required by law after proper noticing by submitting a speaker slip (located on the back table) to the City Clerk. After considering all of the evidence, including written materials and oral testimony, the City Council must make a decision supported by findings and the findings must be supported by substantial evidence in the record. An applicant or designee(s) for a private development/business project, for which the public hearing is being held, is allotted a total of fifteen minutes to speak, as per SBMC 2.04.210. A portion of the fifteen minutes may be saved to respond to those who speak in opposition. *All other speakers should refer to the public comment section at the beginning of the agenda for time allotment.* Please be aware of the timer light on the Council Dais.

B.1. Public Hearing: 1246 Highland Dr., Applicant: Brent & Leslie Stringer, Application: DRP21-005. (File 0600-40)

The proposed project meets the minimum zoning requirements under the SBMC, may be found to be consistent with the General Plan and may be found, as conditioned, to meet the discretionary findings required as discussed in this report to approve a DRP. Therefore, Staff recommends that the City Council:

1. Conduct the Public Hearing: Open the Public Hearing, Report Council Disclosures, Receive Public Testimony, and Close the Public Hearing.
2. Find the project exempt from the California Environmental Quality Act pursuant to Section 15301 of the State CEQA Guidelines; and
3. If the City Council makes the requisite findings and approves the project, adopt **Resolution 2022-031** conditionally approving a DRP to construct a 721 square-foot addition to an existing split level, single-family residence with a detached 1,176 square-foot, two-story garage/storage building, and perform associated site improvements at 1246 Highland Drive, Solana Beach.

[Item B.1. Report \(click here\)](#)

Posted Reports & Supplemental Docs contain records up to the cut off time, prior to the start of the meeting, for processing new submittals. The final official record containing handouts, PowerPoints, etc. can be obtained through a Records Request to the City Clerk's Office.

C. STAFF REPORTS: (C.1. – C.4.)

Submit speaker slips to the City Clerk.

All speakers should refer to the public comment section at the beginning of the agenda for time allotments. Please be aware of the timer light on the Council Dais.

C.1. Parks and Recreation Commission Appointment. (File 0120-06)

Recommendation: That the City Council

1. Consider the applications submitted and appoint one (1) member to the Parks and Recreation Commission nominated/appointed by *Council-at-large* for a term ending January 2024.

[Item C.1. Report \(click here\)](#)

Posted Reports & Supplemental Docs contain records up to the cut off time, prior to the start of the meeting, for processing new submittals. The final official record containing handouts, PowerPoints, etc. can be obtained through a Records Request to the City Clerk's Office.

C.2. Introduce (1st Reading) Ordinance 523 - Regulating the Use, Sale and Distribution of Balloons filled with Gas Lighter than Air. (File 0220-70)

Recommendation: That the City Council

1. Introduce **Ordinance 523** amending Title 5 and adding Chapter 5.07 to the Solana Beach Municipal Code to address the Use, Sale and Distribution of Balloons Filled with Gas Lighter than Air.

[Item C.2. Report \(click here\)](#)

Posted Reports & Supplemental Docs contain records up to the cut off time, prior to the start of the meeting, for processing new submittals. The final official record containing handouts, PowerPoints, etc. can be obtained through a Records Request to the City Clerk's Office.

C.3. Adopt (2nd Reading) Ordinance 522 - Regulating Non-Serialized Untraceable Ghost Guns. (File 0250-70)

Recommendation: That the City Council

1. Adopt **Ordinance 522** amending Chapter 7.20 and adding Chapter 7.20.040 to the Solana Beach Municipal Code to address non-serialized untraceable ghost guns.

[Item C.3. Report \(click here\)](#)

Posted Reports & Supplemental Docs contain records up to the cut off time, prior to the start of the meeting, for processing new submittals. The final official record containing handouts, PowerPoints, etc. can be obtained through a Records Request to the City Clerk's Office.

C.4. Introduce (1st Reading) Ordinance 516 – Electronic Filing of Campaign Statements. (File 0430-50)

Recommendation: That the City Council

1. Introduce **Ordinance 516** related to electronic campaign statements, adding Section 2.24.085 Electronic Filing of Campaign Statements to the Solana Beach Municipal Code.

[Item C.4. Report \(click here\)](#)

Posted Reports & Supplemental Docs contain records up to the cut off time, prior to the start of the meeting, for processing new submittals. The final official record containing handouts, PowerPoints, etc. can be obtained through a Records Request to the City Clerk's Office.

WORK PLAN COMMENTS:

Adopted June 23, 2021

COMPENSATION & REIMBURSEMENT DISCLOSURE:

GC: Article 2.3. Compensation: 53232.3. (a) Reimbursable expenses shall include, but not be limited to, meals, lodging, and travel. 53232.3 (d) Members of a legislative body shall provide brief reports on meetings attended at the expense of the local agency "City" at the next regular meeting of the legislative body.

COUNCIL COMMITTEE REPORTS: [Council Committees](#)

REGIONAL COMMITTEES: (outside agencies, appointed by this Council)

- a. City Selection Committee (meets twice a year) Primary-Heebner, Alternate-Edson
- b. Clean Energy Alliance (CEA) JPA: Primary-Becker, Alternate-Zito
- c. County Service Area 17: Primary- Harless, Alternate-Edson
- d. Escondido Creek Watershed Authority: Becker /Staff (no alternate).
- e. League of Ca. Cities' San Diego County Executive Committee: Primary-Becker, Alternate- Harless. Subcommittees determined by its members.
- f. League of Ca. Cities' Local Legislative Committee: Primary-Harless, Alternate-Becker
- g. League of Ca. Cities' Coastal Cities Issues Group (CCIG): Primary-Becker, Alternate-Harless
- h. North County Dispatch JPA: Primary-Harless, Alternate-Becker
- i. North County Transit District: Primary-Edson, Alternate-Harless
- j. Regional Solid Waste Association (RSWA): Primary-Harless, Alternate-Zito
- k. SANDAG: Primary-Heebner, 1st Alternate-Zito, 2nd Alternate-Edson. Subcommittees determined by its members.
- l. SANDAG Shoreline Preservation Committee: Primary-Becker, Alternate-Zito
- m. San Dieguito River Valley JPA: Primary-Harless, Alternate-Becker
- n. San Elijo JPA: Primary-Zito, Primary-Becker, Alternate-City Manager
- o. 22nd Agricultural District Association Community Relations Committee: Primary-Edson, Primary-Heebner

STANDING COMMITTEES: (All Primary Members) (Permanent Committees)

- a. Business Liaison Committee – Zito, Edson.
- b. Fire Dept. Management Governance & Organizational Evaluation – Harless, Edson
- c. Highway 101 / Cedros Ave. Development Committee – Edson, Heebner
- d. Parks and Recreation Committee – Zito, Harless
- e. Public Arts Committee – Edson, Heebner
- f. School Relations Committee – Becker, Harless
- g. Solana Beach-Del Mar Relations Committee – Heebner, Edson

CITIZEN COMMISSION(S)

- a. Climate Action Commission: Primary-Zito, Alternate-Becker

ADJOURN:

Next Regularly Scheduled Meeting is *May 11, 2022*

Always refer the City's website Event Calendar for updated schedule or contact City Hall.

www.cityofsolanabeach.org 858-720-2400

AFFIDAVIT OF POSTING

STATE OF CALIFORNIA }
COUNTY OF SAN DIEGO } §
CITY OF SOLANA BEACH }

I, Angela Ivey, City Clerk of the City of Solana Beach, do hereby certify that this Agenda for the April 27, 2022 Council Meeting was called by City Council, Successor Agency to the Redevelopment Agency, Public Financing Authority, and the Housing Authority of the City of Solana Beach, California, was provided and posted on April 20, 2022 at xx:xx p.m. on the City Bulletin Board at the entrance to the City Council Chambers. Said meeting is held at 6:00 p.m., April 27, 2022, in the Council Chambers, at City Hall, 635 S. Highway 101, Solana Beach, California.

Angela Ivey, City Clerk
City of Solana Beach, CA

UPCOMING CITIZEN CITY COMMISSION AND COMMITTEE MEETINGS:

Regularly Scheduled, or Special Meetings that have been announced, are posted on each Citizen Commission's Agenda webpage. See the [Citizen Commission's Agenda webpages](#) or the City's Events [Calendar](#) for updates.

- **Budget & Finance Commission**
- **Climate Action Commission**
- **Parks & Recreation Commission**
- **Public Arts Commission**
- **View Assessment Commission**



CITY OF SOLANA BEACH

SOLANA BEACH CITY COUNCIL, SUCCESSOR AGENCY TO THE REDEVELOPMENT AGENCY,
PUBLIC FINANCING AUTHORITY, AND HOUSING AUTHORITY

MINUTES

Joint – Closed Session

Wednesday, February 09, 2022 ♦ 5:00 p.m.

Teleconference Location Only-City Hall/Council Chambers, 635 S. Highway 101, Solana Beach, California
This meeting will be conducted in accordance with Government Code sections 54953(e) and 54954.3 and other applicable law.

CITY COUNCILMEMBERS

Lesa Heebner, Mayor

Kelly Harless
Deputy Mayor

David A. Zito
Councilmember
District 1

Jewel Edson
Councilmember
District 3

Kristi Becker
Councilmember

Gregory Wade
City Manager

Johanna Canlas
City Attorney

Angela Ivey
City Clerk

CALL TO ORDER AND ROLL CALL:

Mayor Heebner called the meeting to order at 5:02 p.m.

Present: Lesa Heebner, Kelly Harless, David A. Zito, Jewel Edson, Kristi Becker,

Absent: None

Also Greg Wade, City Manager

Present: Johanna Canlas, City Attorney

PUBLIC COMMENT ON CLOSED SESSION ITEMS (ONLY): None

CLOSED SESSION:

1. CONFERENCE WITH LEGAL COUNSEL – ANTICIPATED LITIGATION

Pursuant to Government Code Section 54956.9(d)(2)

One (1) Potential case.

2. CONFERENCE WITH LEGAL COUNSEL – INITIATION OF LITIGATION

Pursuant to Government Code Section 54956.9(d)(4)

One (1) Potential case.

3. CONFERENCE WITH LEGAL COUNSEL – EXISTING LITIGATION

Pursuant to Government Code Section 54956.9(d)(1)

Beach & Bluff Conservancy v. City of Solana Beach, California Coastal Commission,
Surfrider (Case No. 37-2019-0002080-CU-WM-NC)

4. CONFERENCE WITH LABOR NEGOTIATORS Pursuant to Government Code Section
(added 2-8-22 11:15am)

54957.6 Agency designated representative: Gregory Wade

Employee organizations: Solana Beach Firefighter's Association

ADJOURN:

Mayor Heebner adjourned the meeting at 6:25 p.m.

Angela Ivey, City Clerk

Approved: _____

Agenda Item # A.1.



CITY OF SOLANA BEACH

SOLANA BEACH CITY COUNCIL, SUCCESSOR AGENCY TO THE REDEVELOPMENT
AGENCY, PUBLIC FINANCING AUTHORITY, AND HOUSING AUTHORITY

MINUTES

Joint REGULAR Meeting

Wednesday, February 09, 2022 * 6:00 p.m.

Teleconference Location Only-City Hall/Council Chambers, 635 S. Highway 101, Solana Beach, California

This meeting was conducted in accordance with California Government Code sections 54953(e) and 54954.3 and other applicable law.

- City Council meetings are video recorded and archived as a permanent record. The video recording captures the complete proceedings of the meeting and is available for viewing on the City's website.
- Posted Reports & Supplemental Docs contain records up to the cut off time prior to meetings for processing new submittals. Complete records containing meeting handouts, PowerPoints, etc. can be obtained through a [Records Request](#).

CITY COUNCILMEMBERS

Lesa Heebner, Mayor

Kelly Harless
Deputy Mayor

David A. Zito
Councilmember
District 1

Jewel Edson
Councilmember
District 3

Kristi Becker
Councilmember

Gregory Wade
City Manager

Johanna Canlas
City Attorney

Angela Ivey
City Clerk

SPEAKERS:

See Public Participation on the first page of the Agenda for publication participation options.

READING OF ORDINANCES AND RESOLUTIONS:

Pursuant to [Solana Beach Municipal Code](#) Section 2.04.460, at the time of introduction or adoption of an ordinance or adoption of a resolution, the same shall not be read in full unless after the reading of the title, further reading is requested by a member of the Council. If any Councilmember so requests, the ordinance or resolution shall be read in full. In the absence of such a request, this section shall constitute a waiver by the council of such reading.

CALL TO ORDER AND ROLL CALL:

Mayor Heebner called the meeting to order at 6:33 p.m.

Present: Lesa Heebner, Kelly Harless, Jewel Edson, Kristi Becker

Absent: David A. Zito

Also Greg Wade, City Manager

Present: Johanna Canlas, City Attorney

Angela Ivey, City Clerk

Dan King, Assistant City Manager

Mo Sammak, City Engineer/Public Works Dir.

Ryan Smith, Finance Dir.

Joseph Lim, Community Development Dir.

CLOSED SESSION REPORT: None

FLAG SALUTE:

PRESENTATIONS: Ceremonial items that do not contain in-depth discussion and no action/direction.

Black History Month

Mayor Heebner read the proclamation for Black History Month.

APPROVAL OF AGENDA:

Motion: Moved by Councilmember Harless and second by Councilmember Becker to approve.
Approved 4/0/1 Ayes: Heebner, Harless, Edson, Becker. Noes: None. Absent: Zito. Motion carried.

ORAL COMMUNICATIONS:

Note to Public: Refer to [Public Participation](#) for information on how to submit public comment.

This portion of the agenda provides an opportunity for members of the public to address the City Council on items relating to City business and not appearing on today's agenda by joining the virtual meeting online to speak live, per the Public Participation instructions on the Agenda. Pursuant to the Brown Act, no action shall be taken by the City Council on public comment items. No written correspondence may be submitted in lieu of public speaking. Council may refer items to the City Manager for placement on a future agenda. The maximum time allotted for each speaker is THREE MINUTES (SBMC 2.04.190).

COUNCIL COMMUNITY ANNOUNCEMENTS / COMMENTARY:

An opportunity for City Council to make brief announcements or report on their activities. These items are not agendaized for official City business with no action or substantive discussion.

A. CONSENT CALENDAR: (Action Items) (A.1. - A.5.)

Note to Public: Refer to [Public Participation](#) for information on how to submit public comment.

Items listed on the Consent Calendar are to be acted in a single action of the City Council unless pulled for discussion.

Any member of the public may address the City Council on an item of concern by submitting written correspondence for the record to be filed with the record or by joining the virtual meeting online to speak live, per the Public Participation instructions on the Agenda. The maximum time allotted for each speaker is THREE MINUTES (SBMC 2.04.190).

Those items removed from the Consent Calendar by a member of the Council will be trailed to the end of the agenda, while Consent Calendar items removed by the public will be discussed immediately after approval of the Consent Calendar.

A.1. Minutes of the City Council.

Recommendation: That the City Council

1. Approve the Minutes of the December 8, 2021 City Council Meetings.

Approved Minutes http://www.ci.solana-beach.ca.us/index.asp?SEC=F0F1200D-21C6-4A88-8AE1-0BC07C1A81A7&Type=B_BASIC

Motion: Moved by Councilmember Edson and second by Deputy Mayor Harless to approve.
Approved 4/0/1 Ayes: Heebner, Harless, Edson, Becker. Noes: None. Absent: Zito. Motion carried.

A.2. Register Of Demands. (File 0300-30)

Recommendation: That the City Council

1. Ratify the list of demands for January 08, 2022 – January 21, 2022.

[Item A.2. Report \(click here\)](#)

Posted Reports & Supplemental Docs contain records up to the cut off time, prior to the start of the meeting, for processing new submittals. The final official record containing handouts, PowerPoints, etc. can be obtained through a Records Request to the City Clerk's Office.

Motion: Moved by Councilmember Edson and second by Deputy Mayor Harless to approve.

Approved 4/0/1 Ayes: Heebner, Harless, Edson, Becker. Noes: None. Absent: Zito. Motion carried.

A.3. General Fund Budget Adjustments for Fiscal Year 2021/2022. (File 0330-30)

Recommendation: That the City Council

1. Receive the report listing changes made to the Fiscal Year 2021/2022 General Fund Adopted Budget.

[Item A.3. Report \(click here\)](#)

Posted Reports & Supplemental Docs contain records up to the cut off time, prior to the start of the meeting, for processing new submittals. The final official record containing handouts, PowerPoints, etc. can be obtained through a Records Request to the City Clerk's Office.

Motion: Moved by Councilmember Edson and second by Deputy Mayor Harless to approve.
Approved 4/0/1 Ayes: Heebner, Harless, Edson, Becker. Noes: None. Absent: Zito. Motion carried.

A.4. Local Emergency Teleconferencing. (File 0240-25)

Recommendation: That the City Council

1. Adopt **Resolution 2022-015** authorizing remote teleconference meetings of the legislative bodies of the City for the period of February 10, 2022 through March 12, 2022 pursuant to the new provisions of the Brown Act.

[Item A.4. Report \(click here\)](#)

Posted Reports & Supplemental Docs contain records up to the cut off time, prior to the start of the meeting, for processing new submittals. The final official record containing handouts, PowerPoints, etc. can be obtained through a Records Request to the City Clerk's Office.

Motion: Moved by Councilmember Edson and second by Deputy Mayor Harless to approve.
Approved 4/0/1 Ayes: Heebner, Harless, Edson, Becker. Noes: None. Absent: Zito. Motion carried.

A.5. Conflict of Interest Code Update. (File 0440-00)

Recommendation: That the City Council

1. Adopt **Resolution 2022-010** adopting an amended Solana Beach Conflict of Interest Code.

[Item A.5. Report \(click here\)](#)

Posted Reports & Supplemental Docs contain records up to the cut off time, prior to the start of the meeting, for processing new submittals. The final official record containing handouts, PowerPoints, etc. can be obtained through a Records Request to the City Clerk's Office.

Motion: Moved by Councilmember Edson and second by Deputy Mayor Harless to approve.
Approved 4/0/1 Ayes: Heebner, Harless, Edson, Becker. Noes: None. Absent: Zito. Motion carried.

B. PUBLIC HEARINGS: (B.1. – B.3.)

Note to Public: Refer to [Public Participation](#) for information on how to submit public comment.

Any member of the public may address the City Council on an item of concern by submitting written correspondence for the record to be filed with the record or by registering to join the

virtual meeting online to speak live, per the Public Participation instructions on the Agenda. The maximum time allotted for each speaker is THREE MINUTES (SBMC 2.04.190).

An applicant or designee(s) for a private development/business project, for which the public hearing is being held, is allotted a total of fifteen minutes to speak, as per SBMC 2.04.210. A portion of the fifteen minutes may be saved to respond to those who speak in opposition. All other speakers have three minutes each.

After considering all of the evidence, including written materials and oral testimony, the City Council must make a decision supported by findings and the findings must be supported by substantial evidence in the record.

B.1. Public Hearing: 135 South Sierra Ave., Applicant: Las Brisas Homeowners Association, Case: CUP20-004. (File 0600-40)

Recommendation: That the City Council

1. Conduct the Public Hearing: Open the Public Hearing, Report Council Disclosures, Receive Public Testimony, and Close the Public Hearing.
2. Find this the Proposed Project exempt from the requirements of CEQA pursuant to 2022 State California CEQA Guidelines §15269 as emergency conditions exist onsite.
3. Adopt **Resolution 2022-013** conditionally approving a Conditional Use Permit Modification to construct a return wall that would consist of a drilled pier/caisson design with structural concrete between piers, extend from the top of the southern terminus of the existing seawall to the top of the bluff, and would be covered with hand sculpted, colored shotcrete to match the adjacent natural bluff at 135 S. Sierra Avenue, Solana Beach.

[Item B.1. Report \(click here\)](#)

[Item B.1. Supplemental Docs \(updated 2-09-22 at 3:01pm\)](#)

Posted Reports & Supplemental Docs contain records up to the cut off time, prior to the start of the meeting, for processing new submittals. The final official record containing handouts, PowerPoints, etc. can be obtained through a Records Request to the City Clerk's Office.

Greg Wade, City Manager, introduced the item.

Corey Andrews, Principal Planner, presented a PowerPoint (on file).

Mayor Heebner opened the public hearing.

Greg Wade, City Manager, spoke about the Surfrider letter reference to a special condition issued by the Coastal Commission in a Coastal Development Permit, that Staff did verify that the mitigation fees were paid in full, that the 2010 approval did not trigger additional mitigation fees, and that Staff was processing this as Conditional Use Permit amendment.

Council and Staff discussed the irrigation capped within one hundred feet of the bluff top, the 2004 seawall conforms with the LCP as an appropriate bluff retention device structure, construction activities during holidays and Fiesta Del Sol, the project was designed to protect the upper bluff fronting the Las Brisas property and not neighboring properties,

Bob Trettin, applicant representative, spoke about doing all or most of the work from the top of the bluff rather than using the beach very long during the holidays or events, the 2005 irrigation capping was required at a 150- foot back exceeding the requirement of this permit, this was a 22-year permit that would need amending no later than 2026 to apply for an

additional 20 years along with mitigation fees, there was no nexus allowing a double charge for the same sand twice,

Brian Caine, Las Brisas Board, said that homeowners were anxious about the collapse and that the project was very important to them.

Council discussed amending the resolution to require that no construction activities occur on the beach between the date of Fiesta Del Sol to Labor Day.

Motion: Moved by Councilmember Edson and second by Councilmember Becker to close the public hearing. **Approved 4/0/1** Ayes: Heebner, Harless, Edson, Becker. Noes: None. Absent: Zito. Motion carried.

Motion: Moved by Councilmember Edson and second by Councilmember Becker to approve including no construction on the beach allowed between May 20th until Labor Day. **Approved 4/0/1** Ayes: Heebner, Harless, Edson, Becker. Noes: None. Absent: Zito. Motion carried.

B.2. Public Hearing Continued: 211 Ocean St., Applicant: Blakely, Case: DRP21-004/ SDP21-004. (File 0600-40)

The proposed project meets the minimum zoning requirements under the SBMC, may be found to be consistent with the General Plan and may be found, as conditioned, to meet the discretionary findings required as discussed in this report to approve a DRP and SDP. Therefore, Staff recommends that the City Council:

1. Conduct the continued Public Hearing: Report Council Disclosures, Receive Public Testimony, and Close the Public Hearing.
2. Find the project exempt from the California Environmental Quality Act pursuant to Section 15303 of the State CEQA Guidelines; and
3. If the City Council makes the requisite findings and approves the project, adopt **Resolution 2021-128** conditionally approving a DRP, SDP, and SDP Waiver to demolish a single-family residence, construct a replacement two-story, single-family residence with an attached two-car garage, and perform associated site improvements at 211 Ocean Street, Solana Beach.

[Item B.2. Report \(click here\)](#)

[Item B.2. Supplemental Docs \(updated 2-09-22 at 1:20pm\)](#)

Posted Reports & Supplemental Docs contain records up to the cut off time, prior to the start of the meeting, for processing new submittals. The final official record containing handouts, PowerPoints, etc. can be obtained through a Records Request to the City Clerk's Office.

Greg Wade, City Manager, introduced the item.

Katie Benson, Sr. Planner, presented a PowerPoint (on file).

Council disclosures.

Ford Blakely, Applicant, presented a PowerPoint (on file) reviewing the history of the project, and spoke about support for the project, changes since the last meeting to address bulk and scale, the project being the most modest plan on the street and having the second smallest ratio for the building square footage, support of six neighbors and an issue with only one neighbor, their review of all of Council's past comments to produce a workable solution, and

asked for approval.

Julie Hamilton (time donated by Ronald Everett, Monty James, Asli Carome) said that they've had no contact with the Blakely's since the View Assessment Commission, there was a significant amount of proposed outdoor living area including a large second story deck, the privacy impacts and bulk and scale concerns, that they were requesting the sill height be raised for the five windows that look onto the Carome's property, the southeast corner balcony be removed or reduced by 120 sq. ft. and move the deck back 10 ft. as well as remove the deck cover.

David Babbe said that he supported Ms. Hamilton's comments and they were only asking him to scale back or move the location of the deck.

Michelle Stribling said that they were never contacted by the Blakely's to discuss the project and any impacts, that mansionized homes were changing the fabric, feel, and lifestyle of the neighborhood, the bulk and scale of the property was maxed out in FAR sq. footage and height, and that the bulk and scale should be greatly reduced.

Erin McBriar said that she was surprised that the neighbor was asking for a deck to be removed after a View Assessment Commission meeting, that the Blakely's worked with her on an easy solution when they proposed a deck facing her pool, that the project appeared to be a reasonable home for the lot size, working with the neighbor to achieve a mutually beneficial solution would be better than minimizing the project at this stage, and that she and four other neighbors have worked with neighbors on issues that arose during and after construction on their own home.

Ford Blakely said that they had an email with Frank Stribling on April 30, 2022 regarding surf updates, his roof deck, and a picture of the image of their project telling them we would be happy to review our plans with them, that he ran into Michelle Stribling on the street and said she loved the project and she thought it would get approved, that the images presented by Ms. Carome and her graphic designers were renditions of how they would like us to design our home, that these obstacles have delayed the project and created friction in the neighborhood, and that they intended to gain their own privacy as well as respect the privacy of their neighbors.

Mayor Heebner said she wanted to address some comments made about her notes from a prior meeting that were suggestions from one Councilmember and not a design recommendation, and that this current design had achieved reducing the bulk and scale.

Councilmember Edson said that she was sympathetic to concerns of Ms. Carome and Mr. Babbe, that the Blakely's had been thoughtful in working with neighbors to reach a compromise by agreeing to reduce the second story deck roof over the desk, that the project was 14 ½ ft. from the east property line which only had to be 5 ft., that a landscape plan was provided on each property line to screen the view into the neighbors' yards, and that the roof deck pushed back had reduced the bulk and scale.

Motion: Moved by Deputy Mayor Harless and second by Mayor Heebner to close the public hearing. **Approved 4/0/1** Ayes: Heebner, Harless, Edson, Becker. Noes: None. Absent: Zito. Motion carried.

Councilmember Harless said that Council works hard to make the best decisions for the community as a whole, that we do not look at impacts on one person, that privacy cannot be protected, and that the deck cover was the main issue with bulk and scale and their reduction had met the requirements and supported the project.

Deputy Mayor Becker said that there was tension and disappointment on both sides, hard to maximize property development, process benefits, the difficulty of maximizing the area of their property, the process was done well to hear all sides, and that the project was better than when it started, and that she could make all of the findings.

Motion: Moved by Deputy Mayor Harless and second by Councilmember Becker to approve. **Approved 4/0/1** Ayes: Heebner, Harless, Edson, Becker. Noes: None. Absent: Zito. Motion carried.

Mayor Heebner adjourned the meeting for a break at 7:52 p.m. and reconvened the meeting at 8:00 p.m.

C. STAFF REPORTS: (C.1. – C.3.)

Note to Public: Refer to [Public Participation](#) for information on how to submit public comment.

Any member of the public may address the City Council on an item of concern by submitting written correspondence for the record to be filed with the record or by registering to join the virtual meeting online to speak live, per the Public Participation instructions on the Agenda. The maximum time allotted for each speaker is THREE MINUTES (SBMC 2.04.190).

C.1. Fiscal Year 2020-21 Annual Comprehensive Financial Report (ACFR).

(File 0310-11)

Recommendation: That the City Council

1. Accept and file the City of Solana Beach Annual Comprehensive Financial Report (ACFR) for the Fiscal Year July 1, 2020 – June 30, 2021.
2. Accept and file the Communication of Internal Control Related Matters identified in an Audit letter.
3. Accept and file the Auditor's Communication with Those Charged with Governance letter.

[Item C.1. Report \(click here\)](#)

Posted Reports & Supplemental Docs contain records up to the cut off time, prior to the start of the meeting, for processing new submittals. The final official record containing handouts, PowerPoints, etc. can be obtained through a Records Request to the City Clerk's Office.

Greg Wade, City Manager, introduced the item.

Ryan Domino, LSL Financial, presented a PowerPoint (on file).

Ryan Smith, Finance Director, continued the PowerPoint (on file).

No action required.

C.2. Citywide Traffic Calming Measures. (File 0860-45)

Recommendation: That the City Council

1. Validate the North Highway 101 Engineering and Traffic Speed Survey performed by STC Traffic.
2. Adopt **Resolution 2022-012** determining that upon the basis of the Engineering and Traffic Speed Survey, that North Highway 101, between Cliff Street and the northern city limit, the speed limit shall be 35 miles per hour, which is the most appropriate speed to facilitate the orderly movement of traffic and is reasonable and safe.
3. Consider and provide direction to Staff on implementing the three proposed traffic calming measures at San Mario, South Sierra, and Santa Helena.

[Item C.2. Report \(click here\)](#)

[Item C.2. Supplemental Docs \(updated 2-09-22 at 1:20pm\)](#)

Posted Reports & Supplemental Docs contain records up to the cut off time, prior to the start of the meeting, for processing new submittals. The final official record containing handouts, PowerPoints, etc. can be obtained through a Records Request to the City Clerk's Office.

Greg Wade, City Manager, introduced the item.

Jennifer Kuzman said that the speed cushion petition for S. Sierra was needed from the neighbors adjacent to the proposed area, in which the City's own property would be one of the neighbors, and is asking for support and approval from the City to continue working with Public Works Director to gain the remaining signatures.

Karl Rudnick said that low intermittent obstacles were prohibited in California Highway design, to remove the choker idea on Santa Helena and consider a two-foot buffer as an alternate solution, and adding more frequent cross hatching.

Council and Staff discussed traffic Sheriff Deputy locations and frequency on streets, patrolling at night for traffic violations such as speeding, trying the 2 ft. buffer on Santa Helena, the loud sound that street dots generate, taking a speed survey to track the impact of the calming measures, using a combination of striping and race pavement markers (RPMs) within a two-foot buffer zone, reflective painting options on flat paving, and crosshatching.

David DiPierro, STC Traffic, spoke about various colors used for pavements, using thermoplastic as reflective, concerns about street dots near bike lanes, and implementing measures in small steps.

Motion: Moved by Councilmember Edson and second by Deputy Mayor Harless to approve and paint a 2 ft. buffer, instead of a proposed choker, narrowing the lanes on the downhill side to 10 ft. using more cross hatching and looking at thermoplastic striping. **Approved 4/0/1** Ayes: Heebner, Harless, Edson, Becker. Noes: None. Absent: Zito. Motion carried.

C.3. SANDAG 2021 Annual Report. (File 0150-55)

Recommendation: That the City Council

1. Receive the report of SANDAG's 2021 Annual Report.

[Item C.3. Report \(click here\)](#)

[Item C.3. Updated Report #1 \(added 2-9 at 1:20pm\)](#)

Posted Reports & Supplemental Docs contain records up to the cut off time, prior to the start of the meeting, for processing new

Greg Wade, City Manager, introduced the item and said that Assembly Bill 805 requires that a representative member of the local jurisdiction provide an annual report made available by SANDAG 2021.

Mayor Heebner reported that the Regional Transportation Plan (RTP) is a document required by state and federal law, that it includes a mandate to reduce greenhouse gas emissions including vehicle miles traveled. The Plan, or the Five Big Moves, are 1) complete corridors by way of managed lanes, 2) transit leap which also includes commuter trail, light rail, rapid buses, and ferry, 3) mobility hubs as major connection points, 4) flexible fleets which would provide different mobility services, and 5) Next Operating System (Next OS) which is a digital platform that compiles information from various sources in a centralize data hub for analysis to improve how transportation is planned, operated, and experienced. She said that noted in the report were purple lines that connect from Tijuana airport to various places in the county that would someday connect to the mid-coast trolley, the Blue Line Express which would be a high-speed grade separated train, relocating the LOSSAN corridor off of the bluffs in Del Mar, and federal and state funding to Transnet.

Councilmember Edson reported that North County pays approximately 30% of the taxes to Transnet but would only receive a 20% split at this time, adding trains to the coaster with newer and cleaner locomotives, and adding more frequent trips to increase mass transit options.

Mayor Heebner said that a proposed tax to drivers was removed as a funding source for projects, that there was a citizens' initiative being circulated to increase taxation to a half a cent sales tax countywide for funding some measures in the MTS zone, which would not include Solana Beach, and that there would be other anticipated sales tax measures coming from SANDAG throughout the years.

Council reached consensus to send a letter regarding potential changes to the TransNet ordinance.

COMPENSATION & REIMBURSEMENT DISCLOSURE:

GC: Article 2.3. Compensation: 53232.3. (a) Reimbursable expenses shall include, but not be limited to, meals, lodging, and travel. 53232.3 (d) Members of a legislative body shall provide brief reports on meetings attended at the expense of the local agency "City" at the next regular meeting of the legislative body.

COUNCIL COMMITTEE REPORTS: [Council Committees](#)

REGIONAL COMMITTEES: (outside agencies, appointed by this Council)

STANDING COMMITTEES: (All Primary Members) (Permanent Committees)

CITIZEN COMMISSION(S)

ADJOURN:

Mayor Heebner adjourned the meeting at 9:42 p.m.



CITY OF SOLANA BEACH

SOLANA BEACH CITY COUNCIL, SUCCESSOR AGENCY TO THE REDEVELOPMENT AGENCY,
PUBLIC FINANCING AUTHORITY, AND HOUSING AUTHORITY

MINUTES

Joint – Closed Session

Wednesday, March 02, 2022 ♦ 3:30 p.m.

Teleconference Location Only-City Hall/Council Chambers, 635 S. Highway 101, Solana Beach, California
This meeting will be conducted in accordance with Government Code sections 54953(e) and 54954.3 and other applicable law.

CITY COUNCILMEMBERS

Lesa Heebner, Mayor

Kelly Harless
Deputy Mayor

David A. Zito
Councilmember
District 1

Jewel Edson
Councilmember
District 3

Kristi Becker
Councilmember

Gregory Wade
City Manager

Johanna Canlas
City Attorney

Angela Ivey
City Clerk

CALL TO ORDER AND ROLL CALL:

Mayor Heebner called the meeting to order at 3:30 p.m.

Present: Lesa Heebner, Kelly Harless, David A. Zito, Jewel Edson, Kristi Becker,

Absent: None

Also Greg Wade, City Manager

Present: Johanna Canlas, City Attorney

PUBLIC COMMENT ON CLOSED SESSION ITEMS (ONLY): None

CLOSED SESSION:

1. CONFERENCE WITH LEGAL COUNSEL – ANTICIPATED LITIGATION

Pursuant to Government Code Section 54956.9(d)(2)

Two (2) Potential cases.

2. CONFERENCE WITH LABOR NEGOTIATORS

Pursuant to Government Code Section 54957.6

Agency designated representative: Gregory Wade

Employee organizations: Miscellaneous Employees, Marine Safety Unit, Solana Beach Firefighter’s Association, and Unrepresented Employees.

3. CONFERENCE WITH LEGAL COUNSEL – INITIATION OF LITIGATION

Pursuant to Government Code Section

54956.9(d)(4) Two (2) Potential case(s).

No Reportable Action

ADJOURN:

Mayor Heebner adjourned the meeting at 5:10 p.m.

Megan Bavin, Deputy City Clerk

Council Approved:



STAFF REPORT CITY OF SOLANA BEACH

TO: Honorable Mayor and City Councilmembers
FROM: Gregory Wade, City Manager
MEETING DATE: April 27, 2022
ORIGINATING DEPT: Finance
SUBJECT: Register of Demands

BACKGROUND:

Section 3.04.020 of the Solana Beach Municipal Code requires that the City Council ratify a register of demands which represents all financial demands made upon the City for the applicable period.

Register of Demands- 03/26/22 through 04/15/22

Check Register-Disbursement Fund (Attachment 1)		\$	1,132,294.85
Net Payroll M20	April 1, 2022		270,083.83
Retirement Payroll	April 7, 2022		4,051.00
Council Payroll	April 14, 2022		6,063.32
Net Payroll M21	April 15, 2022		<u>255,304.63</u>
TOTAL		\$	<u><u>1,667,797.63</u></u>

DISCUSSION:

Staff certifies that the register of demands has been reviewed for accuracy, that funds are available to pay the above demands, and that the demands comply with the adopted budget.

CEQA COMPLIANCE STATEMENT:

Not a project as defined by CEQA.

FISCAL IMPACT:

The register of demands for March 26, 2022 through April 15, 2022 reflects total expenditures of \$1,667,797.63 from various City sources.

WORK PLAN:

N/A

CITY COUNCIL ACTION: _____

OPTIONS:

- Ratify the register of demands.
- Do not ratify and provide direction.

DEPARTMENT RECOMMENDATION:

Staff recommends that the City Council ratify the above register of demands.

CITY MANAGER'S RECOMMENDATION:

Approve Department Recommendation.

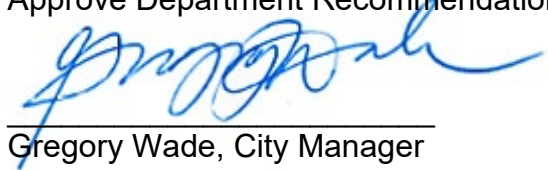
A handwritten signature in blue ink, appearing to read "Gregory Wade", is written over a horizontal line.

Gregory Wade, City Manager

Attachments:

1. Check Register – Disbursement Fund



City of Solana Beach

Register of Demands

3/26/2022 - 4/15/2022

Department Vendor	Description	Date	Check/EFT Number	Amount
100 - GENERAL FUND				
ICMA PLAN 302817	Payroll Run 1 - Warrant M20	03/31/2022	9000460	\$15,332.31
ICMA PLAN 302817	Payroll Run 1 - Warrant M21	04/14/2022	9000468	\$21,483.29
SOLANA BEACH FIREFIGHTERS ASSOC	Payroll Run 1 - Warrant M20	03/31/2022	9000464	\$850.00
SOLANA BEACH FIREFIGHTERS ASSOC	Payroll Run 1 - Warrant M21	04/14/2022	9000473	\$850.00
US BANK	MM-MISAC CONFERENCE	04/08/2022	101661	\$872.73
US BANK	MM-TRAVEL REIMBURSEMENT	04/08/2022	101661	\$56.28
LEGAL SHIELD CORP	PPD LEGAL-MAR 22	04/08/2022	101670	\$38.85
AFLAC	AFLAC-MARCH 21	03/31/2022	101624	\$803.86
SAN DIEGO COUNTY SHERIFF'S DEPT.	CR TOW FEE-DEC/STAFF-DEC	03/31/2022	101649	(\$328.26)
SAN DIEGO COUNTY SHERIFF'S DEPT.	CR TOW FEE-JAN	04/14/2022	101707	(\$109.42)
DEPARTMENT OF CONSERVATION	SMIP FEES-JAN-MAR 22	04/14/2022	101697	\$1,886.43
DEPARTMENT OF CONSERVATION	SMIP FEES-JAN-MAR 22	04/14/2022	101697	\$32.07
ICMA RHS 801939	Payroll Run 1 - Warrant M20	03/31/2022	9000461	\$1,953.96
ICMA RHS 801939	Payroll Run 1 - Warrant M21	04/14/2022	9000469	\$1,960.07
STERLING HEALTH SERVICES, INC.	M20 FSA/SCA CONTRIBUTIONS	04/08/2022	9000466	\$1,343.75
STERLING HEALTH SERVICES, INC.	M20 FSA/SCA CONTRIBUTIONS	04/08/2022	9000466	\$439.77
PACIFIC WEST SPACE COMMUNICATIONS	RFND-DOUBLE PAYMENT ON BC RENEWAL	04/08/2022	101677	\$48.00
PACIFIC WEST SPACE COMMUNICATIONS	RFND-DOUBLE PAYMENT ON BC RENEWAL	04/08/2022	101677	\$4.00
MEGAN J HALVEY MESSAGE THERAPY	RFND-DOUBLE PAID ON BC	04/08/2022	101672	\$231.00
MEGAN J HALVEY MESSAGE THERAPY	RFND-DOUBLE PAID ON BC	04/08/2022	101672	\$103.00
MEGAN J HALVEY MESSAGE THERAPY	RFND-DOUBLE PAID ON BC	04/08/2022	101672	\$4.00
MEGAN J HALVEY MESSAGE THERAPY	RFND-DOUBLE PAID ON BC	04/08/2022	101672	\$4.00
ERICKSON-HALL CONSTRUCTION COMPANY	RFND-ENC20-0145/780 SANTA VICTORIA	04/14/2022	101699	\$774.00
SARAH MOLARUIS	RFND-SB-0636940	04/14/2022	101708	\$70.50
FRANCHISE TAX BOARD	GARNISHMENT ORD#633140172933902746 PD041522	04/14/2022	101700	\$803.62
TOTAL GENERAL FUND				\$49,507.81
1005150 - CITY CLERK				
IRON MOUNTAIN	RECORDS STORAGE-MAR	04/08/2022	101669	\$521.77
IRON MOUNTAIN	RECORDS STORAGE-APRIL	04/08/2022	101669	\$765.96
STAPLES CONTRACT & COMMERCIAL	BADGE REELS/PAPER TOWELS	03/31/2022	101654	\$40.17
US BANK	AI-BADGES	04/08/2022	101661	\$16.14
US BANK	GA-MINUTES TRANSCRIPT	04/08/2022	101661	\$30.25
US BANK	GA-DATE STAMPER	04/08/2022	101661	\$152.67
US BANK	GA-MINUTES TRANSCRIPT	04/08/2022	101661	\$48.50
US BANK	AI-CA MUNICIPAL HANDBOOK	04/08/2022	101661	\$196.51
US BANK	AI-SOUND PROOFING	04/08/2022	101661	\$43.09
UT SAN DIEGO - NRTH COUNTY	COMMISSIONS VOLUNTEER AD	04/08/2022	101688	\$250.00
ROBERT HALF	Temp Front Desk -03/11/21	03/31/2022	101648	\$1,652.80
ROBERT HALF	Temp Front Desk-03/04/22	03/31/2022	101648	\$1,652.80

ROBERT HALF	Temp Front Desk-02/18/22	03/31/2022	101648	\$1,652.80
ROBERT HALF	Temp Front Desk--12/24/21	03/31/2022	101648	\$1,624.40
CORODATA RECORDS MANAGEMENT, INC	DESTRUCTION-09/02/21	03/31/2022	101630	\$154.12
CORODATA RECORDS MANAGEMENT, INC	RECORDS STORAGE-OCT 21	03/31/2022	101630	\$476.28
CORODATA RECORDS MANAGEMENT, INC	RECORDS STORAGE-FEB 22	03/31/2022	101630	\$600.86
CODE PUBLISHING COMPANY INC	WEB HOSTING 21-22	04/08/2022	101663	\$425.00

TOTAL CITY CLERK**\$10,304.12****1005200 - CITY MANAGER**

US BANK	AU-WALL CALENDAR	04/08/2022	101661	\$15.93
US BANK	GW-LA TIMES 6MNTH SUBSCPT	04/08/2022	101661	\$51.87
US BANK	KM-RFND STORAGE TOTE	04/08/2022	101661	(\$49.54)
ICMA MEMBERSHIP RENEWALS	WADE-MEMEBERSHIP 2022	04/14/2022	101702	\$1,400.00

TOTAL CITY MANAGER**\$1,418.26****1005250 - LEGAL SERVICES**

HOGAN LAW APC	GENERAL LEGAL-FEB	04/14/2022	101701	\$877.50
NOSSAMAN LLP	PROF SERVICE-JAN	03/31/2022	101644	\$180.00
NOSSAMAN LLP	PROF SERVICE-FEB	03/31/2022	101644	\$3,467.36
BURKE WILLIAMS & SORENSEN	JAN'22 - 96-0001 CITY ATTORNEY SVCS	04/08/2022	101660	\$5,109.00
BURKE WILLIAMS & SORENSEN	JAN'22 - 96-0001.003 SB9 ORD	04/08/2022	101660	\$340.00
BURKE WILLIAMS & SORENSEN	JAN'22 - 96-0002 CODE ENF	04/08/2022	101660	\$736.00
BURKE WILLIAMS & SORENSEN	JAN'22 - 96-0006 PERSONNEL	04/08/2022	101660	\$1,753.33
BURKE WILLIAMS & SORENSEN	JAN'22 - 96-0014 REDLGH T CMRA CITATIONS	04/08/2022	101660	\$381.00
BURKE WILLIAMS & SORENSEN	JAN'22 - 96-0019 VIEW ASSESSMENT COMMISSION	04/08/2022	101660	\$1,000.00
BURKE WILLIAMS & SORENSEN	JAN'22 - 96-0027 BEACH BLUFF CONSV V CITY	04/08/2022	101660	\$120.00
BURKE WILLIAMS & SORENSEN	JAN'22 - 96-0033 COVID19	04/08/2022	101660	\$2,100.00
BURKE WILLIAMS & SORENSEN	JAN'22 - 96-0038 NCTD STATION	04/08/2022	101660	\$552.00
BURKE WILLIAMS & SORENSEN	JAN'22 - MONTHLY RETAINER	04/08/2022	101660	\$11,250.00

TOTAL LEGAL SERVICES**\$27,866.19****1005300 - FINANCE**

STAPLES CONTRACT & COMMERCIAL	FIN-PHONE STAND	04/08/2022	101685	\$33.93
STAPLES CONTRACT & COMMERCIAL	FIN-ORGANIZER,AIR FRESHENER	04/08/2022	101685	\$25.92
STAPLES CONTRACT & COMMERCIAL	FIN-LABEL PRINTER	04/08/2022	101685	\$107.74
STAPLES CONTRACT & COMMERCIAL	FIN-CORD MGMT,HIGHLIGHTERS,UTL HOOK	04/08/2022	101685	\$58.23
US BANK	RS-FIN DROP BOX	04/08/2022	101661	\$300.62
US BANK	GW-MASKS FOR CH	04/08/2022	101661	\$193.65
US BANK	KM-BROCHURE HOLDER	04/08/2022	101661	\$26.93
US BANK	RS-FY21 ACFR AWARD FEE	04/08/2022	101661	\$460.00
US BANK	RS-22 CSMFO CONF-HOTEL 2/17/22	04/08/2022	101661	\$268.08
KOPPEL & GRUBER PUBLIC FINANCE	BENEFIT FEE ASSESSMENT DISTRICTS-JAN-MAR	04/14/2022	101703	\$554.98
BARTEL ASSOCIATES, LLC	OPEB VALUATION-JAN	04/14/2022	101691	\$2,100.00
BARTEL ASSOCIATES, LLC	GASBS 75 REPORT/OPEB VALUATION-DEC	04/14/2022	101691	\$9,500.00
BUSINESS PRINTING COMPANY INC	BUSINESS CARDS-THAYER/SITHER	04/14/2022	101693	\$193.93
XEROX CORPORATION	XEROX-CLERK-MAR	04/14/2022	101721	\$78.74
KFORCE INC.	FINANCE TEMP-03/03/22	03/31/2022	101640	\$991.20
KFORCE INC.	FINANCE TEMP-03/10/22	04/14/2022	9000470	\$1,018.24
KFORCE INC.	FINANCE TEMP-03/17/22	04/14/2022	9000470	\$1,031.20
KFORCE INC.	FINANCE TEMP-03/24/22	04/14/2022	9000470	\$1,021.44

HR DIRECT	1095-C KIT	04/08/2022	101668	\$242.97
TOTAL FINANCE				\$18,207.80
1005350 - SUPPORT SERVICES				
STAPLES CONTRACT & COMMERCIAL	CEN-PENS	04/08/2022	101685	\$14.02
STAPLES CONTRACT & COMMERCIAL	CEN-BATTERIES,SHARPIE,PAPER,NOTEPAD	04/08/2022	101685	\$232.48
STAPLES CONTRACT & COMMERCIAL	CEN-COPY PAPER,POST IT	04/08/2022	101685	\$274.20
STAPLES CONTRACT & COMMERCIAL	CEN-DISPOSABLE MASKS	04/08/2022	101685	\$80.76
US BANK	KM-OFFICE FURNITURE	04/08/2022	101661	\$619.52
BUSINESS PRINTING COMPANY INC	WINDOW ENVELOPES	04/14/2022	101693	\$933.46
XEROX CORPORATION	XEROX-UPSTAIRS-MAR	04/14/2022	101721	\$46.67
XEROX CORPORATION	XEROX-UPSTAIRS-MAR	04/14/2022	101721	\$298.25
XEROX CORPORATION	XEROX-PLANNING-MAR	04/14/2022	101721	\$158.61
XEROX CORPORATION	XEROX-PLANNING-MAR	04/14/2022	101721	\$546.78
XEROX CORPORATION	XEROX-CLERK-MAR	04/14/2022	101721	\$271.68
XEROX CORPORATION	XEROX-FIERY-PLAN-MAR	04/14/2022	101721	\$132.61
XEROX CORPORATION	XEROX-FIERY-UPSTAIRS-MAR	04/14/2022	101721	\$132.61
XEROX CORPORATION	XEROX-FIERY-CLERK-MAR	04/14/2022	101721	\$122.84
JENNIFER REED	ADMIN AVC-FEB	04/14/2022	9000472	\$84.50
TOTAL SUPPORT SERVICES				\$3,948.99
1005400 - HUMAN RESOURCES				
SHARP REES-STEALY MEDICAL CTRS INC	PRE-EMPLOYMENT SCREENING	03/31/2022	101651	\$279.00
SHARP REES-STEALY MEDICAL CTRS INC	PRE-EMPLOYMENT SCREEN	04/14/2022	101710	\$264.50
US BANK	KM-PICTURE FRAMES	04/08/2022	101661	\$25.84
US BANK	PS-LINKEDIN ANNUAL MMBRSHIP	04/08/2022	101661	\$323.88
US BANK	PS-LABOR LAW POSTERS	04/08/2022	101661	\$311.07
US BANK	PS-SPACE HEATER	04/08/2022	101661	\$80.80
US BANK	PS-PRINTER INK	04/08/2022	101661	\$230.34
US BANK	PS-2022 COVID LEAVE SMNR	04/08/2022	101661	\$100.00
POUNEH SAMMAK	RFND-GIFT CARDS/PANEL MEMBERS	03/31/2022	101647	\$120.00
DONNOE & ASSOCIATES, INC	FIRE ENGINEER EXAM/BOOKS	03/31/2022	101634	\$385.00
JULIETTE THAYER	TUITION REIMB-THAYER-ECON FOR MANAGERS	04/14/2022	9000474	\$1,010.00
PRIMO INVESTIGATIONS	BACKGROUND CHECK-CODE	04/08/2022	101680	\$325.00
DEPARTMENT OF JUSTICE	FINGERPRINT APP-FEB	03/31/2022	101632	\$96.00
PRISM	PEPM-67 EMPLOYEES-APR-JUN 22	04/14/2022	101706	\$418.08
TOTAL HUMAN RESOURCES				\$3,969.51
1005450 - INFORMATION SERVICES				
COX COMMUNICATIONS INC	0013410039730701-03/19-04/18	04/14/2022	101695	\$313.28
US BANK	AT&T	04/08/2022	101661	\$53.50
US BANK	MM-WEB CAMS (COVID-19)	04/08/2022	101661	\$402.06
US BANK	AT&T	04/08/2022	101661	\$64.20
US BANK	AT&T	04/08/2022	101661	\$64.20
US BANK	MM-HEAD SETS (COVID-19)	04/08/2022	101661	\$96.81
US BANK	MM-IT SUPPLIES	04/08/2022	101661	\$68.46
US BANK	MM-USB ADAPTERS	04/08/2022	101661	\$58.14
US BANK	MM-USB ADAPTERS	04/08/2022	101661	\$86.19
US BANK	MM-LABEL MAKER TAPE	04/08/2022	101661	\$7.53
US BANK	MM-8 POWERSTRIPS	04/08/2022	101661	\$213.68

US BANK	MM-PRINTER	04/08/2022	101661	\$280.14
US BANK	MM-POWER SUPPLY	04/08/2022	101661	\$87.12
US BANK	MM-ADOBE LICENSE	04/08/2022	101661	\$128.51
US BANK	MM-SCANNER CABLES/POWER CRD	04/08/2022	101661	\$197.66
US BANK	MM-ADOBE LICENSE	04/08/2022	101661	\$239.88
US BANK	MM-ADOBE LICENSE	04/08/2022	101661	\$119.88
US BANK	MM-WARRANTY OFFICE EQUIP	04/08/2022	101661	\$33.99
US BANK	MM-PORT AIR FOR SERVER RM	04/08/2022	101661	\$785.71
US BANK	DK-CONSTANT CONTACT	04/08/2022	101661	\$55.00
US BANK	DK-HOSTING DOMAINS	04/08/2022	101661	\$9.95
US BANK	DK-CONSTANT CONTACT	04/08/2022	101661	\$55.00
US BANK	DK-HOSTING DOMAINS	04/08/2022	101661	\$9.95
VERIZON WIRELESS-SD	670601022-02/24-03/23	04/14/2022	101717	\$152.04
GOLDEN TELECOM, INC.	PHONE REPLACEMENT	03/31/2022	101637	\$260.50
WESTERN AUDIO VISUAL	CHAMBERS TECH-APR	04/14/2022	101718	\$499.00
AT&T CALNET 3	9391062899-01/24/22-02/23/22	03/31/2022	101625	\$167.08
AT&T CALNET 3	9391012278-01/24/22-02/23/22	03/31/2022	101625	\$3,242.02

TOTAL INFORMATION SERVICES**\$7,751.48****1005550 - PLANNING**

US BANK	JL-APACA END OF SINGLE UNIT	04/08/2022	101661	\$15.00
US BANK	CA-OFFICE SUPPLIES	04/08/2022	101661	\$150.65
UT SAN DIEGO - NRTH COUNTY	PUB HRNG-DRP 21-012/SDP 21-014	04/08/2022	101688	\$268.02
UT SAN DIEGO - NRTH COUNTY	PUB HRNG-DRP20-006/SDP21-010	04/08/2022	101688	\$391.68
1 STOP TONER & INKJET, LLC	TONER-PLN/BLDG	04/14/2022	101705	\$657.23

TOTAL PLANNING**\$1,482.58****1005560 - BUILDING SERVICES**

US BANK	CA-OFFICE SUPPLIES	04/08/2022	101661	\$120.27
1 STOP TONER & INKJET, LLC	TONER-PLN/BLDG	04/14/2022	101705	\$657.23
ESGIL CORPORATION	BUILDING-FEB 22	03/31/2022	101635	\$16,686.30

TOTAL BUILDING SERVICES**\$17,463.80****1005590 - PARKING ENFORCEMENT**

US BANK	CA-OFFICE SUPPLIES	04/08/2022	101661	\$51.69
DATATICKET INC.	FEB22 PARKING TICKET PROCESSING	04/08/2022	101666	\$515.88
DATATICKET INC.	DEC21 PARKING TICKET PROCESSING	04/08/2022	101666	\$566.22
VERIZON WIRELESS-SD	442224168-1-02/24-03/23	04/14/2022	101717	\$141.27
BILL SMITH FOREIGN CAR SERVICE INC	FORD-OIL CHANGE/FILTER	03/31/2022	101626	\$45.37
1 STOP TONER & INKJET, LLC	TONER-CODE	04/14/2022	101705	\$117.23
WEX FLEET UNIVERSAL	AUTO FUEL-02/08/22-03/07/22	04/08/2022	101689	\$46.62

TOTAL PARKING ENFORCEMENT**\$1,484.28****1006110 - LAW ENFORCEMENT**

SAN DIEGO COUNTY SHERIFF'S DEPT.	LAW ENFORCEMENT-DEC 21	03/31/2022	101649	\$391,125.33
SAN DIEGO COUNTY SHERIFF'S DEPT.	CR TOW FEE-DEC/STAFF-DEC	03/31/2022	101649	(\$4,025.58)
SAN DIEGO COUNTY SHERIFF'S DEPT.	LAW ENFORCEMENT-JAN 22	04/14/2022	101707	\$391,125.33
SAN DIEGO COUNTY SHERIFF'S DEPT.	STAFF-JAN	04/14/2022	101707	(\$4,025.58)

TOTAL LAW ENFORCEMENT**\$774,199.50****1006120 - FIRE DEPARTMENT**

US BANK	EP-SPARKPLUGS	04/08/2022	101661	\$23.77
---------	---------------	------------	--------	---------

US BANK	EP-AIR CLEANER	04/08/2022	101661	\$18.18
US BANK	CH-COUPLER/AIR TOOL FITTING	04/08/2022	101661	\$48.31
US BANK	CH-CORDLESS HAMMER DRILL	04/08/2022	101661	\$429.92
US BANK	MS-BASIN CCAI MEM/TRAINING	04/08/2022	101661	\$460.00
US BANK	JM-FS CLEANING SUPPLIES	04/08/2022	101661	\$774.65
US BANK	EP-SPARKPLUGS	04/08/2022	101661	\$65.80
US BANK	MM-ZOHO DESK RENEWAL 2022	04/08/2022	101661	\$960.00
US BANK	MM-SOLID STATE DRIVE	04/08/2022	101661	\$107.74
US BANK	MM-PORTABLE SSD DRIVE	04/08/2022	101661	\$148.05
US BANK	MM-WARRANTY PRT SSD DRIVE	04/08/2022	101661	\$14.99
US BANK	JS-FUEL	04/08/2022	101661	\$431.95
CULLIGAN OF SAN DIEGO	WATER FLTR-04/01-05/31	04/08/2022	101665	\$91.60
ACE UNIFORMS & ACCESSORIES	SHIRTS/TIE/BEANIE/PATCH	03/31/2022	101623	\$496.76
PARKHOUSE TIRE INC	T237-TIRES	04/08/2022	101678	\$1,732.08
WEX BANK	AUTO FUEL-FEB	04/14/2022	101719	\$1,796.10
WEX BANK	CR EXEMPT TAX-FEB	04/14/2022	101719	(\$86.02)
WEX FLEET UNIVERSAL	AUTO FUEL-02/08/22-03/07/22	04/08/2022	101689	\$458.50

TOTAL FIRE DEPARTMENT**\$7,972.38****1006130 - ANIMAL CONTROL**

HABITAT PROTECTION, INC	DEAD ANIMAL REMOVAL-MAR	03/31/2022	101646	\$145.00
HABITAT PROTECTION, INC	DEAD ANIMAL REMOVAL SVC-MAR	04/08/2022	101679	\$145.00

TOTAL ANIMAL CONTROL**\$290.00****1006170 - MARINE SAFETY**

CAMEO PAPER & JANITORIAL SUPPLY INC	TIDE/DISINFECTANT/TOWELS	03/31/2022	101628	\$123.37
US BANK	JS-EMT CERT	04/08/2022	101661	\$145.50
US BANK	GU-OFFICE SUPPLIES	04/08/2022	101661	\$25.84
US BANK	GU-EMR RECERT	04/08/2022	101661	\$40.00
US BANK	EM-DIVE TEST RECERT	04/08/2022	101661	\$20.00
US BANK	EM-SHIPPING -RETURN	04/08/2022	101661	\$13.28
US BANK	JP-HQ OFFICE & CLN SUPPLIES	04/08/2022	101661	\$132.15
US BANK	JP-HQ OFFICE & CLN SUPPLIES	04/08/2022	101661	\$87.30
US BANK	EM-CLEANING SUPPLIES	04/08/2022	101661	\$29.08
BILL SMITH FOREIGN CAR SERVICE INC	FRONTR-OIL CHANGE/FILTER	03/31/2022	101626	\$47.40
BILL SMITH FOREIGN CAR SERVICE INC	BREAK REPLACEMENT/OIL FILTERS/ROTOR PADS	04/14/2022	101692	\$1,871.65
SHULTZ AUDIO VIDEO	SPEAKER REPAIR	03/31/2022	101652	\$2,464.00
WEX FLEET UNIVERSAL	AUTO FUEL-02/08/22-03/07/22	04/08/2022	101689	\$535.32

TOTAL MARINE SAFETY**\$5,534.89****1006510 - ENGINEERING**

DEL MAR BLUE PRINT COMPANY, INC.	MAP	03/31/2022	101631	\$18.49
UNDERGROUND SVC ALERT OF SOCAL INC	DIG ALERT-MAR	04/14/2022	101715	\$87.55
WEX FLEET UNIVERSAL	AUTO FUEL-02/08/22-03/07/22	04/08/2022	101689	\$143.38
STATE CONTROLLER'S OFFICE	ANNUAL STREET REPORT FY21/22	04/14/2022	101711	\$2,633.60
T.Y. LIN INTERNATION	LSF OVERHEAD BRIDGE MAINT DESIGN & SUPPORT SVC-FEB	04/08/2022	101687	\$9,060.00

TOTAL ENGINEERING**\$11,943.02****1006520 - ENVIRONMENTAL SERVICES**

MISSION LINEN & UNIFORM INC	LAUNDRY-PW	03/31/2022	101642	\$13.62
-----------------------------	------------	------------	--------	---------

MISSION LINEN & UNIFORM INC	LAUNDRY-PUB WORKS	04/08/2022	101673	\$13.62
CONSOLIDATED ELECTRICAL DIST INC	LED/SOCKET	03/31/2022	101629	\$2,333.22
WEX FLEET UNIVERSAL	AUTO FUEL-02/08/22-03/07/22	04/08/2022	101689	\$417.09
RECYCLE AWAY LLC	RSWA-HHW CITY FACILITIES RECYCLE BINS	04/08/2022	101681	\$6,990.51
TOTAL ENVIRONMENTAL SERVICES				\$9,768.06

1006530 - STREET MAINTENANCE

MISSION LINEN & UNIFORM INC	LAUNDRY-PW	03/31/2022	101642	\$23.35
MISSION LINEN & UNIFORM INC	LAUNDRY-PUB WORKS	04/08/2022	101673	\$23.35
DIXIELINE LUMBER CO INC	BLACKTOP PATCH	03/31/2022	101633	\$170.14
DIXIELINE LUMBER CO INC	BLACKTOP PATCH	03/31/2022	101633	\$129.19
DIXIELINE LUMBER CO INC	BLACK TOP PATCH	04/14/2022	101698	\$129.19
SDG&E CO INC	UTILITES-02/08-03/10	04/14/2022	101709	\$884.32
SDG&E CO INC	UTILITES-02/01-03/10	04/14/2022	101709	\$567.85
NAPA AUTO PARTS INC	REFRIGERANT	03/31/2022	101643	\$58.71
US BANK	AP-PW PHONE CASES/ CHRGRS	04/08/2022	101661	\$108.78
US BANK	AP-FOUNTAIN TIMER/TRASH BAGS	04/08/2022	101661	\$50.04
US BANK	AP-CHAINSAW CHAIN	04/08/2022	101661	\$31.67
JOSHUA BLEA	MILEAGE-12/29 & 12/31	04/08/2022	101659	\$28.00
NISSHO OF CALIFORNIA	CITY-WIDE LANDSCAPE MAINT SRVC-FEB	04/08/2022	101675	\$1,827.01
WEX FLEET UNIVERSAL	AUTO FUEL-02/08/22-03/07/22	04/08/2022	101689	\$378.00
TOTAL STREET MAINTENANCE				\$4,409.60

1006540 - TRAFFIC SAFETY

SDG&E CO INC	UTILITES-02/08-03/10	04/14/2022	101709	\$1,142.02
SDG&E CO INC	UTILITES-02/01-03/10	04/14/2022	101709	\$538.09
REDFLEX TRAFFIC SYSTEMS, INC	RED LIGHT CAMERA-MAR	04/14/2022	9000471	\$7,158.00
AT&T CALNET 3	9391012279- TRAFFIC SYSTEMS-02/24-03/23	04/08/2022	101658	\$47.31
STC TRAFFIC, INC	ON-CALL TRAFFIC CONSULTING-NOV 21	04/14/2022	101712	\$3,040.00
STC TRAFFIC, INC	ON-CALL TRAFFIC CONSULTING-DEC 21	04/14/2022	101712	\$3,135.00
STC TRAFFIC, INC	ON-CALL TRAFFIC CONSULTING-JAN 22	04/14/2022	101712	\$2,865.00
TOTAL TRAFFIC SAFETY				\$17,925.42

1006560 - PARK MAINTENANCE

MISSION LINEN & UNIFORM INC	LAUNDRY-PW	03/31/2022	101642	\$16.54
MISSION LINEN & UNIFORM INC	LAUNDRY-PUB WORKS	04/08/2022	101673	\$16.54
DIXIELINE LUMBER CO INC	PEWTER SPRAY	03/31/2022	101633	\$7.85
SANTA FE IRRIGATION DISTRICT	005979-005-12/02/21-02/01/22	04/08/2022	101682	\$119.80
JOSHUA BLEA	MILEAGE-12/29 & 12/31	04/08/2022	101659	\$56.00
NISSHO OF CALIFORNIA	CITY-WIDE LANDSCAPE MAINT SRVC-FEB	04/08/2022	101675	\$16,594.07
THE HOME DEPOT PRO	BLEACH/LINERS/CLEANER POLISH/GRAFFITI RMVR	03/31/2022	101655	\$181.18
THE HOME DEPOT PRO	LINERS	03/31/2022	101655	\$541.22
WEX FLEET UNIVERSAL	AUTO FUEL-02/08/22-03/07/22	04/08/2022	101689	\$78.21
TOTAL PARK MAINTENANCE				\$17,611.41

1006570 - PUBLIC FACILITIES

SEASIDE HEATING & AIR CONDITIONING	HVAC SERVICES-LCCC-JAN	03/31/2022	101650	\$120.00
SEASIDE HEATING & AIR CONDITIONING	HVAC SERVICES -FCCC-JAN	03/31/2022	101650	\$65.00
SEASIDE HEATING & AIR CONDITIONING	HVAC SERVICES -MS-JAN	03/31/2022	101650	\$65.00
SEASIDE HEATING & AIR CONDITIONING	HVAC SERVICES -FS-JAN	03/31/2022	101650	\$120.00
SEASIDE HEATING & AIR CONDITIONING	HVAC SERVICES -PW-JAN	03/31/2022	101650	\$245.00

SEASIDE HEATING & AIR CONDITIONING	HVAC SERVICES COUNCIL CHAMBERS-1 OF 2	04/08/2022	101683	\$980.00
SEASIDE HEATING & AIR CONDITIONING	HVAC SERVICES COUNCIL CHAMBERS-2 OF 2	04/08/2022	101683	\$980.00
SEASIDE HEATING & AIR CONDITIONING	HVAC SERVICES AT CITY FACILITIES-CH	04/08/2022	101683	\$356.00
DSR - DOOR SERVICE & REPAIR, INC	AS NEEDED REPAIR-02/21	04/08/2022	101667	\$495.00
DIXIELINE LUMBER CO INC	DIMMER/BLANK PLATE	03/31/2022	101633	\$21.10
DIXIELINE LUMBER CO INC	SNAP IN CONNECTOR/WALL PLATE	03/31/2022	101633	\$14.88
DIXIELINE LUMBER CO INC	DISPOSAL	03/31/2022	101633	\$128.22
DIXIELINE LUMBER CO INC	SOAP/LOTION DISPENSER	03/31/2022	101633	\$45.28
DIXIELINE LUMBER CO INC	CLOSET REBUILD KITS	03/31/2022	101633	\$70.66
DIXIELINE LUMBER CO INC	PLIERS/WRENCH/PRUNER/SNIPPERS	04/14/2022	101698	\$103.87
SDG&E CO INC	UTILITES-02/08-03/10	04/14/2022	101709	\$6,706.09
SDG&E CO INC	UTILITES-02/01-03/10	04/14/2022	101709	\$1,776.17
US BANK	AP-HANDSANTIZER (COVID-19)	04/08/2022	101661	\$26.88
US BANK	AP-CH LIGHTING/FOOT SWITCH	04/08/2022	101661	\$270.90
NISSHO OF CALIFORNIA	CITY-WIDE LANDSCAPE MAINT SRVC-FEB	04/08/2022	101675	\$2,509.06
CINTAS CORPORATION NO. 2	FIRST AID SUPPLIES-CH	04/08/2022	101662	\$67.19
SUNBELT RENTALS, INC.	TROUBLESHOOT MACHINE	04/08/2022	101686	\$540.00
STANDARD PLUMBING SUPPLY COMPANY	CEMENT/BALL VALVE	03/31/2022	101653	\$17.86
STANDARD PLUMBING SUPPLY COMPANY	RFND-INVOICE NYPD30	03/31/2022	101653	(\$69.69)
STANDARD PLUMBING SUPPLY COMPANY	FAUCET/PIPE/FLEX SEAL	03/31/2022	101653	\$174.47
STANDARD PLUMBING SUPPLY COMPANY	PANEL	03/31/2022	101653	\$96.39
STANDARD PLUMBING SUPPLY COMPANY	FS-FRIDGE REPLACEMENT PARTS	04/08/2022	101684	\$104.96
WEX FLEET UNIVERSAL	AUTO FUEL-02/08/22-03/07/22	04/08/2022	101689	\$130.34
TOTAL PUBLIC FACILITIES				\$16,160.63
1007100 - COMMUNITY SERVICES				
US BANK	KM-HEAVY DUTY STAPLER	04/08/2022	101661	\$13.89
TOTAL COMMUNITY SERVICES				\$13.89
1007110 - GF-RECREATION				
US BANK	KW-TRANSLATION-MEMORIAL Day	04/08/2022	101661	\$30.00
1 STOP TONER & INKJET, LLC	TONER-LC	03/31/2022	101645	\$84.91
CALIFORNIA OFFICE CLEANING, INC	CUSTODIAL SRVC FOR FCCC PRIVATE EVENTS-JAN	03/31/2022	101627	\$270.00
WEX FLEET UNIVERSAL	AUTO FUEL-02/08/22-03/07/22	04/08/2022	101689	\$75.54
TOTAL GF-RECREATION				\$460.45
1205460 - SELF INSURANCE RETENTION				
GEORGE HILLS COMPANY, INC.	CLM. GENR PROF SVC-FEB	03/31/2022	101636	\$117.00
GEORGE HILLS COMPANY, INC.	CLM.2205 PROF SVC-FEB	03/31/2022	101636	\$162.00
GEORGE HILLS COMPANY, INC.	CLM.1904 PROF SVC-FEB	03/31/2022	101636	\$135.00
GEORGE HILLS COMPANY, INC.	CLM. GENR PROF SVC-FEB	03/31/2022	101636	\$63.00
GEORGE HILLS COMPANY, INC.	CLM. GENR PROF SVC-FEB	03/31/2022	101636	\$63.00
BURKE WILLIAMS & SORENSEN	JAN'22 - 96-0007.001 HUNTER CLAIM	04/08/2022	101660	\$414.00
TOTAL SELF INSURANCE RETENTION				\$954.00
1355200 - ASSET REPLACEMENT-CTY MNGR				
TYLER TECHNOLOGIES, INC.	50/50 WORK SPLIT-MAR	04/14/2022	101714	\$1,799.49
TOTAL ASSET REPLACEMENT-CTY MNGR				\$1,799.49
1355300 - ASSET REPLACEMENT-FINANCE				
TYLER TECHNOLOGIES, INC.	50/50 WORK SPLIT-MAR	04/14/2022	101714	\$3,800.51
TOTAL ASSET REPLACEMENT-FINANCE				\$3,800.51

1605360 - OPEB OBLIGATION

MIDAMERICA	CTYSOLANAG5-APR 22	04/08/2022	9000465	\$6,889.00
TOTAL OPEB OBLIGATION				\$6,889.00

2037510 - HIGHWAY 101 LANDSC #33

SDG&E CO INC	UTILITES-02/08-03/10	04/14/2022	101709	\$2,817.47
KOPPEL & GRUBER PUBLIC FINANCE	BENEFIT FEE ASSESSMENT DISTRICTS-JAN-MAR	04/14/2022	101703	\$730.61
NISSHO OF CALIFORNIA	CITY-WIDE LANDSCAPE MAINT SRVC-FEB	04/08/2022	101675	\$2,079.50
TOTAL HIGHWAY 101 LANDSC #33				\$5,627.58

2047520 - MID 9C SANTA FE HILLS

SANTA FE IRRIGATION DISTRICT	005979-006-12/02/21-02/01/22	04/08/2022	101682	\$130.21
SANTA FE IRRIGATION DISTRICT	005979-007-12/02/21-02/01/22	04/08/2022	101682	\$132.35
SANTA FE IRRIGATION DISTRICT	005979-009-12/02/21-02/01/22	04/08/2022	101682	\$124.04
SANTA FE IRRIGATION DISTRICT	005979-010-12/02/21-02/01/22	04/08/2022	101682	\$123.34
SANTA FE IRRIGATION DISTRICT	005979-011-12/02/21-02/01/22	04/08/2022	101682	\$121.32
SANTA FE IRRIGATION DISTRICT	005979-012-12/02/21-02/01/22	04/08/2022	101682	\$117.47
KOPPEL & GRUBER PUBLIC FINANCE	BENEFIT FEE ASSESSMENT DISTRICTS-JAN-MAR	04/14/2022	101703	\$48.56
SANTA FE HILLS HOA	MONTHLY SFH MID PAYMENT	03/31/2022	9000463	\$18,333.33
TOTAL MID 9C SANTA FE HILLS				\$19,130.62

2057530 - MID 9E ISLA VERDE

KOPPEL & GRUBER PUBLIC FINANCE	BENEFIT FEE ASSESSMENT DISTRICTS-JAN-MAR	04/14/2022	101703	\$24.98
TOTAL MID 9E ISLA VERDE				\$24.98

2077550 - MID 9H SAN ELIJO #2

KOPPEL & GRUBER PUBLIC FINANCE	BENEFIT FEE ASSESSMENT DISTRICTS-JAN-MAR	04/14/2022	101703	\$26.36
TOTAL MID 9H SAN ELIJO #2				\$26.36

2087580 - COASTAL RAIL TRAIL MAINT

NISSHO OF CALIFORNIA	CITY-WIDE LANDSCAPE MAINT SRVC-FEB	04/08/2022	101675	\$3,996.53
TOTAL COASTAL RAIL TRAIL MAINT				\$3,996.53

2117600 - STREET LIGHTING DISTRICT

SDG&E CO INC	UTILITES-02/01-03/10	04/14/2022	101709	\$8,872.32
TOTAL STREET LIGHTING DISTRICT				\$8,872.32

2135550 - DEVELOPER PASS-THRU- PLANNING

HARRIS & ASSOC. INC.	B21-0507/678 SAN MARIO DR	03/31/2022	101638	\$1,120.00
HARRIS & ASSOC. INC.	B21-0507/678 SAN MARIO DR	03/31/2022	101638	\$1,880.00
MICHAEL BAKER INTERNATIONAL, INC	1718.03/0 IDA AVE	03/31/2022	101641	\$1,400.00
CTE, INC	CUP20-004/135 S. SIERRA AVE	04/08/2022	101664	\$1,250.00
CTE, INC	CUP20-004 LAS BRISAS AT 135 S SIERRA-FEB	04/14/2022	101696	\$260.00
SUMMIT ENVIROMENTAL GROUP, INC.	1714.29-SOLANA HIGHLANDS-FEB	04/08/2022	9000467	\$1,380.00
TOTAL DEVELOPER PASS-THRU- PLANNING				\$7,290.00

2196110 - COPS PROGRAM

SAN DIEGO COUNTY SHERIFF'S DEPT.	LAW ENFORCEMENT-DEC 21	03/31/2022	101649	\$12,000.00
SAN DIEGO COUNTY SHERIFF'S DEPT.	LAW ENFORCEMENT-JAN 22	04/14/2022	101707	\$12,000.00
TOTAL COPS PROGRAM				\$24,000.00

2286510 - TRANSNET EXTENSION-CIP

MW PELTZ + ASSOCIATES INC	9525 ST HELENA TRAIL-MAR	04/14/2022	101704	\$13,800.00
CHEN RYAN ASSOCIATES	9538.22 SAFE RT SCH-FEB	04/14/2022	101694	\$3,194.81
TOTAL TRANSNET EXTENSION-CIP				\$16,994.81

2406510 - COMM DEV BLOCK GR (CDBG)-CIP

UT SAN DIEGO - NRTH COUNTY	INVITING BID-2022-04	03/31/2022	101656	\$293.74
----------------------------	----------------------	------------	--------	----------

TOTAL COMM DEV BLOCK GR (CDBG)-CIP**\$293.74****2466510 - PER CAPITA GRANT FUND-CIP**

CHEN RYAN ASSOCIATES	9538.22 SAFE RT SCH-FEB	04/14/2022	101694	\$9,584.44
----------------------	-------------------------	------------	--------	------------

TOTAL PER CAPITA GRANT FUND-CIP**\$9,584.44****2505570 - COASTAL BUSINESS/VISITORS**

US BANK	KW-EGG HUNT SUPPLIES	04/08/2022	101661	\$475.45
---------	----------------------	------------	--------	----------

TOTAL COASTAL BUSINESS/VISITORS**\$475.45****2706120 - PUBLIC SAFETY- FIRE**

US BANK	RB-MEDICAL SUPPLIES CSA.17	04/08/2022	101661	\$435.58
---------	----------------------------	------------	--------	----------

NATIONWIDE MEDICAL SURGICAL INC	CSA17.22 EPINEPHRINE	04/08/2022	101674	\$245.00
---------------------------------	----------------------	------------	--------	----------

L. N. CURTIS & SONS INC	Curtis - Vortex-SYSTEM AZTEK PROSERIES	04/08/2022	101671	\$1,765.10
-------------------------	--	------------	--------	------------

TOTAL PUBLIC SAFETY- FIRE**\$2,445.68****2706170 - PUBLIC SAFETY- MARINE SAFETY**

US BANK	EM-MEDICAL SUPPLIES (CSA-17)	04/08/2022	101661	\$109.91
---------	------------------------------	------------	--------	----------

US BANK	GU-MEDICAL SUPPLIES	04/08/2022	101661	\$315.81
---------	---------------------	------------	--------	----------

TOTAL PUBLIC SAFETY- MARINE SAFETY**\$425.72****4506190 - SAND REPLNSHMNT/RETENTION**

SUMMIT ENVIROMENTAL GROUP, INC.	9926 PROF SVC SND-FEB	04/08/2022	9000467	\$1,380.00
---------------------------------	-----------------------	------------	---------	------------

TOTAL SAND REPLNSHMNT/RETENTION**\$1,380.00****5097700 - SANITATION**

MISSION LINEN & UNIFORM INC	LAUNDRY-PW	03/31/2022	101642	\$9.73
-----------------------------	------------	------------	--------	--------

MISSION LINEN & UNIFORM INC	LAUNDRY-PUB WORKS	04/08/2022	101673	\$9.73
-----------------------------	-------------------	------------	--------	--------

AFFORDABLE PIPELINE SERVICES INC	SEWER-PREVENTIVE	04/08/2022	101657	\$425.00
----------------------------------	------------------	------------	--------	----------

AFFORDABLE PIPELINE SERVICES INC	SEWER-URINAL-R	04/08/2022	101657	\$425.00
----------------------------------	----------------	------------	--------	----------

SANTA FE IRRIGATION DISTRICT	005979-008-12/02/21-02/01/22	04/08/2022	101682	\$117.18
------------------------------	------------------------------	------------	--------	----------

PACIFIC SAFETY CENTER	MEMBERSHIP RENEWAL 11/21-10/22	04/08/2022	101676	\$145.00
-----------------------	--------------------------------	------------	--------	----------

AT&T CALNET 3	9391012277-SEWER -2/24-3/23	04/08/2022	101658	\$15.63
---------------	-----------------------------	------------	--------	---------

WEX FLEET UNIVERSAL	AUTO FUEL-02/08/22-03/07/22	04/08/2022	101689	\$156.41
---------------------	-----------------------------	------------	--------	----------

TOTAL SANITATION**\$1,303.68****5507750 - SOLANA ENERGY ALLIANCE**

INBOUND DESIGN INC.	SEA WEBSITE MAINT-OCT	03/31/2022	101639	\$49.00
---------------------	-----------------------	------------	--------	---------

INBOUND DESIGN INC.	SEA WEBSITE MAINT-NOV	03/31/2022	101639	\$49.00
---------------------	-----------------------	------------	--------	---------

INBOUND DESIGN INC.	SEA WEBSITE MAINT-DEC	03/31/2022	101639	\$49.00
---------------------	-----------------------	------------	--------	---------

INBOUND DESIGN INC.	SEA WEBSITE MAINT-JAN	03/31/2022	101639	\$49.00
---------------------	-----------------------	------------	--------	---------

INBOUND DESIGN INC.	SEA WEBSITE MAINT-FEB	03/31/2022	101639	\$49.00
---------------------	-----------------------	------------	--------	---------

INBOUND DESIGN INC.	SEA WEBSITE MAINT-MAR	03/31/2022	101639	\$49.00
---------------------	-----------------------	------------	--------	---------

TOSDAL APC	SEA PROF SVC-NOV	04/14/2022	101713	\$3,089.00
------------	------------------	------------	--------	------------

TOTAL SOLANA ENERGY ALLIANCE**\$3,383.00****6527820 - SUCCESSOR AGENCY**

URBAN FUTURES INC	2017 TAX ALLOC BONDS	04/14/2022	101716	\$775.00
-------------------	----------------------	------------	--------	----------

TOTAL SUCCESSOR AGENCY**\$775.00****6718510 - BARBARA UNDERGROUNDING-DS**

WILLDAN	CONT DISCL FY22 - BARBARA/GRANADOS BOND	04/08/2022	101690	\$750.00
---------	---	------------	--------	----------

WILLDAN	BARBARA-JAN-MAR 22	04/08/2022	101690	\$280.60
---------	--------------------	------------	--------	----------

WILLDAN	RVN BND-BARB-OCT-DEC 21	04/14/2022	101720	\$348.24
TOTAL BARBARA UNDERGROUNDING-DS				\$1,378.84
6728520 - PACIFIC UNDERGROUNDING-DS				
WILLDAN	CONT DISCL FY22 - PACIFIC BOND	04/08/2022	101690	\$250.00
WILLDAN	PACIFIC-JAN-MAR 22	04/08/2022	101690	\$259.02
WILLDAN	RVN BND-PACIFIC-OCT-DEC 21	04/14/2022	101720	\$278.95
TOTAL PACIFIC UNDERGROUNDING-DS				\$787.97
6738530 - MARSOLAN UNDERGROUNDNG-DS				
WILLDAN	MARSOLAN-JAN-MAR 22	04/08/2022	101690	\$257.09
WILLDAN	RVN BND-MARSOLAN-OCT-DEC 21	04/14/2022	101720	\$272.75
TOTAL MARSOLAN UNDERGROUNDNG-DS				\$529.84
6768560 - SO SOLANA SEWER DISTR-DS				
KOPPEL & GRUBER PUBLIC FINANCE	SO SOL SWR-JAN-MAR	04/14/2022	101703	\$431.22
TOTAL SO SOLANA SEWER DISTR-DS				\$431.22
REPORT TOTAL:				\$1,132,294.85



STAFF REPORT CITY OF SOLANA BEACH

TO: Honorable Mayor and City Councilmembers
FROM: Gregory Wade, City Manager
MEETING DATE: April 27, 2022
ORIGINATING DEPT: Finance
SUBJECT: Report on Changes Made to the General Fund Adopted Budget for Fiscal Year 2021-22

BACKGROUND:

Staff provides a report at each Council meeting that lists changes made to the current Fiscal Year (FY) General Fund Adopted Budget. The information provided in this Staff Report lists the changes made through April 13, 2022.

DISCUSSION:

The following table on the next page reports the revenue, expenditures, and transfers for 1) the Adopted General Fund Budget approved by Council on June 23, 2021 (Resolution 2021-092) and 2) any resolutions passed by Council that amended the Adopted General Fund Budget.

GENERAL FUND - ADOPTED BUDGET PLUS CHANGES As of April 13, 2022
--

General Fund Operations

Date	Action	Description	Revenues	Expenditures	Transfers from GF	Net Surplus
06/23/2021	Reso 2021-092	Adopted Budget	22,694,100	(20,222,560)	(916,100)	\$ 1,555,440
06/23/2021	Reso 2021-086	Crossing Guards	121,540	(48,984)	-	1,627,996
07/14/2021	Reso 2021-096	FY22 MOU	-	(950)	-	1,627,046
09/08/2021	Reso 2021-103	Landscaping Maintenance Services	-	(40,000)	-	1,587,046
11/10/2021	Reso 2021-125	Street Maintenance and Repairs Project	-	-	(200,000)	1,387,046
02/23/2022	Reso 2022-017	La Colonia Master Plan Update	-	-	(32,140)	1,354,906
02/23/2022	Reso 2022-019	Street Maintenance and Repairs Project	-	-	(17,500)	1,337,406
03/09/2022	Reso 2022-025	FY22 Mid-Year Budget Update	365,000	(358,000)	-	1,344,406
04/13/2022	Reso 2022-034	Economic Consulting Services	-	(30,000)	-	1,314,406

General Fund Unreserved Balance

Date	Action	Description	Revenues	Expenditures	Transfers from GF	Net
10/27/2021	Reso 2021-124	FY21 Surplus- PARS Contribution	-	(455,000)	-	(455,000)

COUNCIL ACTION:

CEQA COMPLIANCE STATEMENT:

Not a project as defined by CEQA

FISCAL IMPACT:

N/A

WORK PLAN:

N/A

OPTIONS:

- Receive the report.
- Do not accept the report

DEPARTMENT RECOMMENDATION:

Staff recommends that the City Council receive the report listing changes made to the FY 2021-2022 General Fund Adopted Budget.

CITY MANAGER'S RECOMMENDATION:

Approve Department Recommendation



Gregory Wade, City Manager



STAFF REPORT CITY OF SOLANA BEACH

TO: Honorable Mayor and City Councilmembers
FROM: Gregory Wade, City Manager
MEETING DATE: April 27, 2022
ORIGINATING DEPT: Finance
SUBJECT: **Quarterly Investment Report**

BACKGROUND:

California Government Code Section 53600 requires timely reporting of local agency investment transactions and portfolio to the agency's legislative body.

This item is before Council to receive a presentation and to accept and file the Cash and Investment Report for the quarter ended March 31, 2022.

DISCUSSION:

The investment objectives for the City of Solana Beach are 1) to provide safety to ensure the preservation of capital in the overall portfolio, 2) to provide sufficient liquidity for cash needs and 3) to generate a market rate of return consistent with the Investment Policy. The performance objective for the portfolio is to earn a total rate of return through a market cycle that is equal to or above the return on the benchmark yield. In order to achieve this objective, the portfolio invests in high-quality fixed income securities that comply with the Investment Policy and all applicable regulations governing the funds.

The attached Quarterly Cash and Investment Report ensures that the City complies with Section 53600. The City's investment portfolio complies with the City's Investment Policy that is approved annually by the City Council. The majority of City funds are invested in Chandler Asset Management (Chandler), Public Agency Retirement Services (PARS), and Local Agency Investment Fund (LAIF).

CEQA COMPLIANCE STATEMENT:

Not a project as defined by CEQA

CITY COUNCIL ACTION:

FISCAL IMPACT:

None

WORK PLAN:

N/A

OPTIONS:

- Receive reports
- Provide direction

DEPARTMENT RECOMMENDATION:

Staff recommends that the City Council accepts and files the attached Cash and Investment Report for the quarter ended March 31, 2022.

CITY MANAGER'S RECOMMENDATION:

Approve Department Recommendation



Gregory Wade, City Manager

Attachments:

1. Cash and Investment Report – March 31, 2022
2. Chandler Asset Quarterly Investment Report- March 31, 2022
3. PARS Trust Monthly Statement – March 31, 2022

**City of Solana Beach
Cash and Investment Report
March 31, 2022**

Type of Investment	Custodian	Maturity	Percent of Portfolio	Cost Value (Rounded)	Market Value (Rounded)	Current Quarter Yield	Quarter Interest Earned (Rounded)	Fiscal Year to Date Interest Earned (Rounded)
General Checking Account	Union Bank of California	On Demand ⁽¹⁾	19.39%	\$ 9,814,650	\$ 9,814,650	N/A	N/A	N/A
Payroll Account	Union Bank of California	On Demand ⁽¹⁾	2.66%	1,344,821	1,344,821	N/A	N/A	N/A
Worker's Comp - Checking	Union Bank of California	On Demand ⁽¹⁾	0.08%	39,749	39,749	N/A	N/A	N/A
Successor Agency - Checking	Union Bank of California	On Demand ⁽¹⁾	0.72%	362,535	362,535	N/A	N/A	N/A
SEA Lockbox	River City Bank	On Demand ⁽¹⁾	0.08%	40,058	40,058	N/A	N/A	N/A
SEA Reserve	River City Bank	On Demand ⁽¹⁾	0.83%	421,034	421,034	0.15%	55	117
Local Agency Investment Fund	State of CA	On Demand ⁽¹⁾	8.09%	4,095,657	4,095,657 ⁽²⁾	0.32%	3,227	15,556
Chandler Asset Management (CMA) Investment Portfolio	US Bank	1 to 3 years	58.83%	29,780,356	29,133,792 ⁽⁵⁾	2.05% ⁽⁶⁾	68,707 ⁽⁷⁾	307,065 ⁽⁷⁾
Public Agency Retirement Services (PARS)	US Bank	Varied	9.32%	4,719,205	4,948,018 ⁽³⁾	-5.10%	(94,804) ⁽⁷⁾	137,200 ⁽⁷⁾
Wells Fargo Advantage Money Market RDA Refunding Bond Series 2017	Wells Fargo Bank (Cash with Fiscal Agent)	Varied	0.00%	13	13 ⁽⁴⁾	N/A	-	-
Total Cash and Investment:			100.00%	\$ 50,618,078	\$ 50,200,327		\$ (22,814)	\$ 459,938

⁽¹⁾ Funds may be withdrawn with 24 hours notice

⁽²⁾ Source: Monthly Pooled Money Investment Account Market Valuation as reported by LAIF (if available)

⁽³⁾ Source: US Bank Asset Summary
⁽⁴⁾ Source: fiscal agent month-end statements.

⁽⁵⁾ Source: US Bank
⁽⁶⁾ Quarter Ending Average Market Yield to Maturity

⁽⁷⁾ Includes realized investment gains/losses of current quarter

I certify that this report accurately reflects all pooled investments and is in compliance with Government Code Section 53640-53646 as amended January 1, 1996, as well as the investment policy of the City of Solana Beach as approved annually by the City Council.

Furthermore, I certify that sufficient investment liquidity and anticipated revenues are available to meet the City's budgeted expenditure requirements for the next six months.

Date 04/15/2022

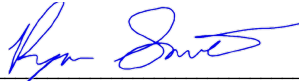
Approved by:
Ryan Smith
Finance Director/Treasurer



City of Solana Beach

MONTHLY ACCOUNT STATEMENT

MARCH 1, 2022 THROUGH MARCH 31, 2022

Chandler Team:

For questions about your account, please call (800) 317-4747,
or contact operations@chandlerasset.com

Custodian

US Bank
Alex Bazan
(503) 464-3685

CHANDLER ASSET MANAGEMENT
chandlerasset.com

Information contained herein is confidential. We urge you to compare this statement to the one you receive from your qualified custodian. Please see Important Disclosures.



PORTFOLIO CHARACTERISTICS

Average Modified Duration	1.74
Average Coupon	0.93%
Average Purchase YTM	1.02%
Average Market YTM	2.05%
Average S&P/Moody Rating	AA+/Aa1
Average Final Maturity	1.93 yrs
Average Life	1.76 yrs

ACCOUNT SUMMARY

	Beg. Values as of 2/28/22	End Values as of 3/31/22
Market Value	27,406,208	29,070,091
Accrued Interest	55,299	63,701
Total Market Value	27,461,507	29,133,792
Income Earned	22,801	22,505
Cont/WD		2,237,056
Par	27,751,883	29,873,163
Book Value	27,723,425	29,780,390
Cost Value	27,723,425	29,780,356

TOP ISSUERS

Government of United States	33.6%
Federal Farm Credit Bank	11.4%
Federal Home Loan Mortgage Corp	7.6%
Federal Home Loan Bank	7.6%
Federal National Mortgage Assoc	6.9%
First American Govt Oblig Fund	2.3%
Honda ABS	1.6%
Toyota ABS	1.6%
Total	72.5%

SECTOR ALLOCATION

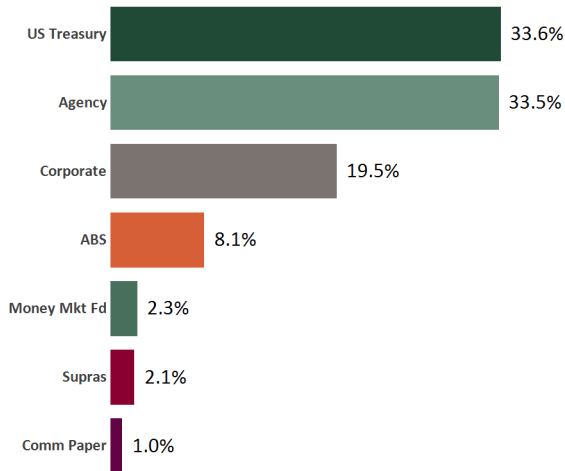

MATURITY DISTRIBUTION

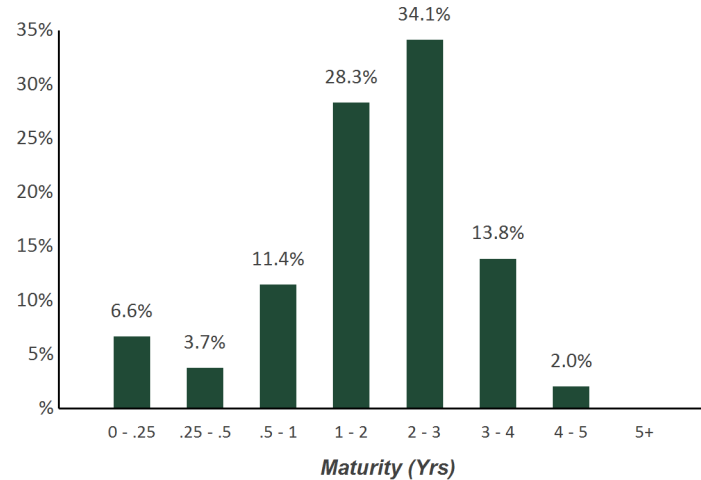

CREDIT QUALITY (S&P)

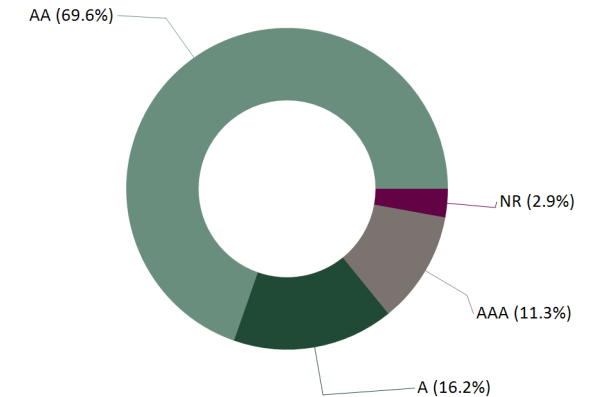

PERFORMANCE REVIEW

TOTAL RATE OF RETURN	Annualized								
	1M	3M	YTD	1YR	2YRS	3YRS	5YRS	10YRS	3/31/2016
City of Solana Beach	-1.18%	-2.21%	-2.21%	-2.60%	-0.81%	1.02%	1.31%	N/A	1.18%
ICE BofA 1-3 Yr US Treasury & Agency Index	-1.33%	-2.34%	-2.34%	-2.84%	-1.30%	0.88%	1.08%	N/A	0.94%

Statement of Compliance

As of March 31, 2022



City of Solana Beach

Assets managed by Chandler Asset Management are in full compliance with state law and the City's investment policy.

Category	Standard	Comment
U.S. Treasuries	No limitations; Full faith and credit of the U.S. are pledged for the payment of principal and interest	<i>Complies</i>
Federal Agencies	30% max per Agency/GSE issuer; 20% max callable agency securities; Federal agencies or U.S. government-sponsored enterprise obligations, participations, or other instruments, including those issued or fully guaranteed as to principal and interest by federal agencies or U.S. government sponsored enterprises.	<i>Complies</i>
Supranational Obligations	"AA" rating category or higher by a Nationally Recognized Statistical Rating Organization ("NRSRO"); 30% max; 10% max per issuer; USD denominated senior unsecured unsubordinated obligations; Issued or unconditionally guaranteed by International Bank for Reconstruction & Development (IBRD), International Finance Corporation (IFC), or Inter-American Development Bank (IADB)	<i>Complies</i>
Municipal Securities (CA, Local Agency)	"A" rating category or higher by a NRSRO; 30% max; 5% max per issuer; Include obligations of the City, State of California, and any local agency within the State of California	<i>Complies</i>
Municipal Securities (CA, Other States)	"A" rating category or higher by a NRSRO; 30% max; 5% max per issuer; Bonds of any of the other 49 states in addition to California, including bonds payable solely out of the revenues from a revenue-producing property owned, controlled, or operated by a state, or by a department, board, agency, or authority of any of the other 49 states, in addition to California.	<i>Complies</i>
Corporate Medium Term Notes	"A" rating category or higher by a NRSRO; 30% max; 5% max per issuer; Issuer is a corporation organized and operating within the U.S. or by depository institutions licensed by the U.S. or any state and operating within the U.S.	<i>Complies</i>
Asset-Backed, Mortgage-Backed, Mortgage Pass-Through Securities, and Collateralized Mortgage Obligations	"AA" rating category or higher by a NRSRO; 20% max (combined ABS/MBS/CMO); 5% max per Asset-Backed or Commercial Mortgage security issuer; There is no issuer limitation on any Mortgage security where the issuer is the U.S. Treasury or a Federal City/GSE; Asset-Backed, Mortgage-Backed, Mortgage Pass-Through Securities, and Collateralized Mortgage Obligations from issuers not defined in section 3 (US Treasuries) and 4 (Federal Agencies) of the Authorized Investments section of the policy	<i>Complies</i>
Negotiable Certificates of Deposit (NCD)	The amount of NCD insured up to the FDIC limit does not require any credit ratings; Any amount above FDIC insured limit must be issued by institutions with "A-1" short-term debt rating or higher by a NRSRO; or "A" long-term rating category or higher by a NRSRO; 30% max (combined with CDARS); 5% max per issuer; Issued by a nationally or state-chartered bank, or a federal or state association, a state or federal credit union, or by a federally-licensed or state-licensed branch of a foreign bank.	<i>Complies</i>
Certificate of Deposit Placement Service (CDARS)	30% max (combination of Certificates of Deposit, including CDARS)	<i>Complies</i>
FDIC Insured Time Deposits (Non-negotiable CD/TD)	Non-Negotiable Certificates of Deposit in state or federally chartered banks, savings and loans, or credit unions; The amount per institution is limited to maximum covered under FDIC; 20% max combined FDIC & Collateralized CD/TD	<i>Complies</i>
Collateralized Time Deposits (Non-negotiable CD/TD)	Non-Negotiable Certificates of Deposit in state or federally chartered banks, savings and loans, or credit unions in excess of insured amounts which are fully collateralized with securities in accordance with California law; 20% max combined FDIC & Collateralized CD/TD	<i>Complies</i>
Collateralized Bank Deposits	City's deposits with financial institutions will be collateralized with pledged securities per California Government Code	<i>Complies</i>
Banker's Acceptances	"A-1" short-term debt rated or higher by a NRSRO; or "A" long-term debt rating category or higher by a NRSRO; 40% max; 5% max per issuer; 180 days max maturity	<i>Complies</i>

Commercial Paper	25% max; 5% max per issuer; 270 days maturity; 10% max of the outstanding paper of any single issuer; Issued by an entity that meets all of the following conditions in either (a) or (b): a. Securities issued by corporations: (i) organized and operating within the U.S. with assets > \$500 million; (ii) "A-1" rated or better by a NRSRO; (iii) "A" rating or better by a NRSRO, if issuer has other debt obligations. b. Securities issued by other entities: (i) organized within the U.S. as a special purpose corporation, trust, or limited liability company; (ii) must have program-wide credit enhancements including, but not limited to, overcollateralization, letters of credit, or a surety bond; (iii) rated "A-1" or better by a NRSRO	Complies
Money Market Mutual Funds	Registered with SEC under Investment Company Act of 1940 and issued by diversified management companies and meet either of the following criteria: (i) Highest rating by two NRSROs; or (ii) Retained an investment adviser registered or exempt from SEC registration with > 5 years experience managing money market mutual funds with AUM >\$500 million; (iii) 20% max per Money Market Mutual Fund; 20% max combined Money Market Mutual Funds and Mutual Funds	Complies
Mutual Funds	Invest in securities as authorized under CGC, Section 53601 (a) to (k) and (m) to (q) inclusive and meet either of the following criteria: (i) Highest rating by two NRSROs; or (ii) Retained an investment adviser registered or exempt from SEC registration with > 5 years experience investing in securities authorized by CGC, Section 53601 and with AUM >\$500 million; (iii) 10% max per Mutual Fund; 20% max combined Money Market Mutual Funds and Mutual Funds	Complies
Local Agency Investment Fund (LAIF)	Maximum amount permitted by LAIF; Not used by investment adviser	Complies
Investment Trust of California (CalTRUST)	Joint powers authority (JPA) organized and managed by the Investment Trust of California JPA for the benefit of local agencies, pursuant to CGC; Not used by investment adviser	Complies
Repurchase Agreements	102% Collateralized; 1 year max maturity; Not used by investment adviser	Complies
Prohibited	Investments not specifically described in the policy; Futures and Options; Inverse floaters; Ranges notes, Mortgage-derived or Interest-only strips; Zero interest accrual securities, if held to maturity; Under a provision sunseting January 1, 2026, securities backed by U.S. Government that could result in a zero- or negative-interest accrual if held to maturity are permitted; Trading securities for the sole purpose of speculating on the future direction of interest rates; Purchasing or selling securities on margin; Reverse repurchase agreements; Securities lending or any other form of borrowing or leverage; Foreign currency denominated securities; Purchases of securities issued by fossil fuel companies that directly source the majority (more than 50%) of their revenue from oil, gas, and or coal production.	Complies
Credit Risk/ Downgrade	If securities owned by the City are downgraded to a level below the requirements of the policy, making the security ineligible for additional purchases, the following steps will be taken: -Any actions taken related to the downgrade by the investment manager will be promptly communicated to the Treasurer; -If a decision is made to retain the security, the credit situation will be monitored and reported to the City Council.	Complies
Duration	typically plus or minus 20% of Benchmark Index	Complies
Max Per Issuer	5% max per issuer, except U.S. Government, its Agencies and GSEs, Supranationals, Money Market Mutual Funds, LAIF, other LGIP, or where otherwise specified in the investment policy	Complies
Maximum Maturity	5 years, except as otherwise stated in the policy	Complies

Reconciliation Summary

As of March 31, 2022



BOOK VALUE RECONCILIATION		
BEGINNING BOOK VALUE		\$27,723,424.61
Acquisition		
+ Security Purchases	\$3,161,952.12	
+ Money Market Fund Purchases	\$820,751.64	
+ Money Market Contributions	\$2,000,000.00	
+ Security Contributions	\$0.00	
+ Security Transfers	\$0.00	
Total Acquisitions		\$5,982,703.76
Dispositions		
- Security Sales	\$1,709,125.00	
- Money Market Fund Sales	\$2,222,379.17	
- MMF Withdrawals	\$4,961.57	
- Security Withdrawals	\$0.00	
- Security Transfers	\$0.00	
- Other Dispositions	\$0.00	
- Maturities	\$0.00	
- Calls	\$0.00	
- Principal Paydowns	\$37,130.82	
Total Dispositions		\$3,973,596.56
Amortization/Accretion		
+/- Net Accretion	\$34.11	
		\$34.11
Gain/Loss on Dispositions		
+/- Realized Gain/Loss	\$47,824.47	
		\$47,824.47
ENDING BOOK VALUE		\$29,780,390.39

CASH TRANSACTION SUMMARY		
BEGINNING BALANCE		\$78,037.88
Acquisition		
Contributions	\$2,000,000.00	
Security Sale Proceeds	\$1,709,125.00	
Accrued Interest Received	\$5,034.25	
Interest Received	\$11,577.63	
Dividend Received	\$0.25	
Principal on Maturities	\$0.00	
Interest on Maturities	\$0.00	
Calls/Redemption (Principal)	\$0.00	
Interest from Calls/Redemption	\$0.00	
Principal Paydown	\$37,130.82	
Total Acquisitions	\$3,762,867.95	
Dispositions		
Withdrawals	\$4,961.57	
Security Purchase	\$3,161,952.12	
Accrued Interest Paid	\$2,543.36	
Total Dispositions	\$3,169,457.05	
ENDING BOOK VALUE		\$671,448.78

Holdings Report

As of March 31, 2022



CUSIP	Security Description	Par Value/Units	Purchase Date Book Yield	Cost Value Book Value	Mkt Price Mkt YTM	Market Value Accrued Int.	% of Port. Gain/Loss	Moody/S&P Fitch	Maturity Duration
ABS									
477870AC3	John Deere Owner Trust 2019-B A3 2.21% Due 12/15/2023	30,964.36	07/16/2019 2.23%	30,957.78 30,957.78	100.27 1.25%	31,046.91 30.41	0.11% 89.13	Aaa / NR AAA	1.71 0.28
43813RAC1	Honda Auto Receivables 2020-1 A3 1.61% Due 4/22/2024	147,092.20	02/19/2020 1.62%	147,063.37 147,063.37	99.93 1.74%	146,990.41 65.78	0.50% (72.96)	Aaa / NR AAA	2.06 0.53
65479JAD5	Nissan Auto Receivables Owner 2019-C A3 1.93% Due 7/15/2024	107,816.93	10/16/2019 1.94%	107,811.24 107,811.24	100.19 1.42%	108,025.77 92.48	0.37% 214.53	Aaa / AAA NR	2.29 0.38
47789KAC7	John Deere Owner Trust 2020-A A3 1.1% Due 8/15/2024	104,840.68	03/04/2020 1.11%	104,834.28 104,834.28	99.68 1.69%	104,508.44 51.26	0.36% (325.84)	Aaa / NR AAA	2.38 0.53
36262XAC8	GM Financial Auto Lease Trust 2021-3 A2 0.39% Due 10/21/2024	190,000.00	08/10/2021 0.39%	189,997.42 189,997.42	97.13 2.54%	184,543.01 22.64	0.63% (5,454.41)	NR / AAA AAA	2.56 1.35
58769KAD6	Mercedes-Benz Auto Lease Trust 2021- B A3 0.4% Due 11/15/2024	130,000.00	06/22/2021 0.40%	129,990.19 129,990.19	97.45 2.42%	126,690.07 23.11	0.43% (3,300.12)	NR / AAA AAA	2.63 1.27
09690AAC7	BMW Vehicle Lease Trust 2021-2 A3 0.33% Due 12/26/2024	85,000.00	09/08/2021 0.34%	84,991.23 84,991.23	97.49 2.43%	82,864.29 4.68	0.28% (2,126.94)	Aaa / NR AAA	2.74 1.20
05601XAC3	BMW Vehicle Lease Trust 2022-1 A3 1.1% Due 3/25/2025	90,000.00	01/11/2022 1.11%	89,986.55 89,986.55	97.51 2.72%	87,761.61 16.50	0.30% (2,224.94)	NR / AAA AAA	2.99 1.55
43813GAC5	Honda Auto Receivables Trust 2021-1 A3 0.27% Due 4/21/2025	65,000.00	02/17/2021 0.27%	64,998.81 64,998.81	97.92 2.54%	63,645.73 4.88	0.22% (1,353.08)	Aaa / NR AAA	3.06 0.92
47788UAC6	John Deere Owner Trust 2021-A A3 0.36% Due 9/15/2025	95,000.00	03/02/2021 0.37%	94,981.74 94,981.74	96.85 2.79%	92,006.65 15.20	0.32% (2,975.09)	Aaa / NR AAA	3.46 1.30
89190GAC1	Toyota Auto Receivables Trust 2021-B A3 0.26% Due 11/17/2025	385,000.00	06/08/2021 0.26%	384,958.54 384,958.54	96.71 2.64%	372,333.50 44.49	1.28% (12,625.04)	NR / AAA AAA	3.64 1.39
43815EAC8	Honda Auto Receivables 2021-3 A3 0.41% Due 11/18/2025	180,000.00	08/17/2021 0.41%	179,997.37 179,997.37	96.40 2.69%	173,521.98 26.65	0.60% (6,475.39)	NR / AAA AAA	3.64 1.60
43815GAC3	Honda Auto Receivables Trust 2021-4 A3 0.88% Due 1/21/2026	90,000.00	11/16/2021 0.89%	89,981.03 89,981.03	96.82 2.58%	87,140.70 22.00	0.30% (2,840.33)	Aaa / NR AAA	3.81 1.89
47789QAC4	John Deere Owner Trust 2021-B A3 0.52% Due 3/16/2026	115,000.00	07/13/2021 0.52%	114,989.74 114,989.74	95.82 2.82%	110,192.77 26.58	0.38% (4,796.97)	Aaa / NR AAA	3.96 1.85

Holdings Report

As of March 31, 2022



CUSIP	Security Description	Par Value/Units	Purchase Date Book Yield	Cost Value Book Value	Mkt Price Mkt YTM	Market Value Accrued Int.	% of Port. Gain/Loss	Moody/S&P Fitch	Maturity Duration
ABS									
89238JAC9	Toyota Auto Receivables Trust 2021-D A3 0.71% Due 4/15/2026	85,000.00	11/09/2021 0.71%	84,998.19 84,998.19	96.22 2.82%	81,790.40 26.82	0.28% (3,207.79)	NR / AAA AAA	4.04 1.81
44935FAD6	Hyundai Auto Receivables Trust 2021-C A3 0.74% Due 5/15/2026	65,000.00	11/09/2021 0.75%	64,985.49 64,985.49	96.10 2.82%	62,464.87 21.38	0.21% (2,520.62)	NR / AAA AAA	4.13 1.90
362554AC1	GM Financial Securitized Term 2021-4 A3 0.68% Due 9/16/2026	70,000.00	10/13/2021 0.68%	69,998.22 69,998.22	96.60 2.67%	67,617.97 19.83	0.23% (2,380.25)	Aaa / AAA NR	4.47 1.73
47787JAC2	John Deere Owner Trust 2022-A A3 2.32% Due 9/16/2026	115,000.00	03/10/2022 2.34%	114,974.56 114,974.56	98.70 2.91%	113,508.68 111.17	0.39% (1,465.88)	Aaa / NR AAA	4.47 2.22
448977AD0	Hyundai Auto Receivables Trust 2022-A A3 2.22% Due 10/15/2026	200,000.00	03/09/2022 2.23%	199,992.30 199,992.30	98.75 2.79%	197,506.00 185.00	0.68% (2,486.30)	NR / AAA AAA	4.55 2.21
380146AC4	GM Financial Auto Receivables 2022-1 A3 1.26% Due 11/16/2026	60,000.00	01/11/2022 1.27%	59,994.79 59,994.79	96.81 3.09%	58,086.66 31.50	0.20% (1,908.13)	NR / AAA AAA	4.63 1.76
Total ABS		2,410,714.17	0.92%	2,410,482.84	2.50%	2,352,246.42 842.36	8.08% (58,236.42)	Aaa / AAA AAA	3.39 1.42
AGENCY									
313379Q69	FHLB Note 2.125% Due 6/10/2022	500,000.00	06/06/2018 2.81%	487,020.50 487,020.50	100.31 0.50%	501,557.00 3,276.04	1.73% 14,536.50	Aaa / AA+ AAA	0.19 0.19
3135G0W33	FNMA Note 1.375% Due 9/6/2022	580,000.00	09/05/2019 1.49%	577,981.60 577,981.60	100.18 0.95%	581,062.56 553.82	2.00% 3,080.96	Aaa / AA+ AAA	0.44 0.43
3133EKY91	FFCB Note 1.375% Due 10/11/2022	500,000.00	10/08/2019 1.46%	498,715.00 498,715.00	100.10 1.19%	500,479.50 3,246.53	1.73% 1,764.50	Aaa / AA+ AAA	0.53 0.52
3130AFE78	FHLB Note 3% Due 12/9/2022	600,000.00	12/20/2018 2.77%	605,208.00 605,208.00	101.12 1.36%	606,721.80 5,600.00	2.10% 1,513.80	Aaa / AA+ AAA	0.69 0.68
3133EKUA2	FFCB Note 1.85% Due 2/1/2023	600,000.00	07/23/2019 1.86%	599,850.00 599,850.00	100.44 1.31%	602,653.80 1,850.00	2.07% 2,803.80	Aaa / AA+ AAA	0.84 0.82
3133ELNWO	FFCB Note 1.45% Due 2/21/2023	600,000.00	02/14/2020 1.45%	599,988.00 599,988.00	100.04 1.40%	600,264.60 966.67	2.06% 276.60	Aaa / AA+ AAA	0.90 0.88

Holdings Report

As of March 31, 2022



CUSIP	Security Description	Par Value/Units	Purchase Date Book Yield	Cost Value Book Value	Mkt Price Mkt YTM	Market Value Accrued Int.	% of Port. Gain/Loss	Moody/S&P Fitch	Maturity Duration
AGENCY									
3133834G3	FHLB Note 2.125% Due 6/9/2023	700,000.00	06/10/2019 2.00%	703,318.00 703,318.00	100.23 1.93%	701,623.30 4,627.78	2.42% (1,694.70)	Aaa / AA+ NR	1.19 1.16
3133EKS7	FFCB Note 1.77% Due 6/26/2023	500,000.00	06/21/2019 1.89%	497,675.00 497,675.00	99.81 1.92%	499,061.00 2,335.42	1.72% 1,386.00	Aaa / AA+ AAA	1.24 1.21
3135G05G4	FNMA Note 0.25% Due 7/10/2023	520,000.00	07/08/2020 0.32%	518,882.00 518,882.00	97.85 1.97%	508,801.28 292.50	1.75% (10,080.72)	Aaa / AA+ AAA	1.28 1.26
3133EL3V4	FFCB Note 0.2% Due 8/14/2023	500,000.00	08/12/2020 0.27%	498,955.00 498,955.00	97.63 1.96%	488,140.00 130.56	1.68% (10,815.00)	Aaa / AA+ AAA	1.37 1.35
3137EAEV7	FHLMC Note 0.25% Due 8/24/2023	475,000.00	08/19/2020 0.28%	474,515.50 474,515.50	97.49 2.08%	463,080.83 122.05	1.59% (11,434.67)	Aaa / AA+ AAA	1.40 1.38
3137EAEW5	FHLMC Note 0.25% Due 9/8/2023	500,000.00	09/29/2020 0.23%	500,310.00 500,310.00	97.48 2.04%	487,424.00 79.86	1.67% (12,886.00)	Aaa / AA+ AAA	1.44 1.42
3137EAEY1	FHLMC Note 0.125% Due 10/16/2023	400,000.00	10/29/2020 0.24%	398,596.00 398,596.00	96.99 2.12%	387,962.40 229.17	1.33% (10,633.60)	Aaa / AA+ AAA	1.55 1.52
3137EAEZ8	FHLMC Note 0.25% Due 11/6/2023	525,000.00	11/03/2020 0.28%	524,527.50 524,527.50	97.04 2.14%	509,464.73 528.65	1.75% (15,062.77)	Aaa / AA+ AAA	1.60 1.58
3135G06H1	FNMA Note 0.25% Due 11/27/2023	465,000.00	11/23/2020 0.29%	464,469.90 464,469.90	96.93 2.15%	450,731.94 400.42	1.55% (13,737.96)	Aaa / AA+ AAA	1.66 1.63
3137EAF2	FHLMC Note 0.25% Due 12/4/2023	375,000.00	12/02/2020 0.28%	374,628.75 374,628.75	96.85 2.17%	363,193.50 304.69	1.25% (11,435.25)	Aaa / AA+ AAA	1.68 1.65
3133EMRZ7	FFCB Note 0.25% Due 2/26/2024	435,000.00	02/22/2021 0.26%	434,843.40 434,843.40	96.53 2.12%	419,895.06 105.73	1.44% (14,948.34)	Aaa / AA+ AAA	1.91 1.88
3130AQF40	FHLB Note 1% Due 12/20/2024	400,000.00	12/21/2021 1.03%	399,648.00 399,648.00	96.23 2.44%	384,908.80 1,100.00	1.32% (14,739.20)	Aaa / AA+ AAA	2.73 2.65
3133ENKS8	FFCB Note 1.125% Due 1/6/2025	205,000.00	01/06/2022 1.20%	204,538.75 204,538.75	96.49 2.44%	197,812.50 512.50	0.68% (6,726.25)	Aaa / AA+ AAA	2.77 2.69
3135G05X7	FNMA Note 0.375% Due 8/25/2025	500,000.00	03/07/2022 1.78%	476,560.00 476,560.00	93.18 2.48%	465,922.00 187.50	1.60% (10,638.00)	Aaa / AA+ AAA	3.41 3.34
Total Agency		9,880,000.00	1.18%	9,840,230.90	1.77%	9,720,760.60 26,449.89	33.46% (119,470.30)	Aaa / AA+ AAA	1.33 1.31

Holdings Report

As of March 31, 2022



CUSIP	Security Description	Par Value/Units	Purchase Date Book Yield	Cost Value Book Value	Mkt Price Mkt YTM	Market Value Accrued Int.	% of Port. Gain/Loss	Moody/S&P Fitch	Maturity Duration
COMMERCIAL PAPER									
62479MJW4	MUFG Bank Ltd/NY Discount CP 1.43% Due 9/30/2022	300,000.00	03/30/2022 1.46%	297,807.33 297,831.16	99.28 1.46%	297,831.16 0.00	1.02% 0.00	P-1 / A-1 NR	0.50 0.50
Total Commercial Paper		300,000.00	1.46%	297,807.33 297,831.16	1.46%	297,831.16 0.00	1.02% 0.00	P-1 / A-1 NR	0.50 0.50
CORPORATE									
084664BT7	Berkshire Hathaway Note 3% Due 5/15/2022	350,000.00	12/11/2018 3.31%	346,510.50 346,510.50	100.24 1.06%	350,823.90 3,966.67	1.22% 4,313.40	Aa2 / AA A+	0.12 0.12
911312BC9	UPS Callable Note Cont 4/16/2022 2.35% Due 5/16/2022	400,000.00	04/10/2018 2.99%	390,204.00 390,204.00	100.08 0.38%	400,323.60 3,525.00	1.39% 10,119.60	A2 / A- NR	0.13 0.04
24422EUA5	John Deere Capital Corp Note 2.7% Due 1/6/2023	350,000.00	10/29/2019 1.96%	357,889.00 357,889.00	100.91 1.50%	353,171.70 2,231.25	1.22% (4,717.30)	A2 / A A	0.77 0.75
037833AK6	Apple Inc Note 2.4% Due 5/3/2023	256,000.00	05/02/2019 2.75%	252,605.44 252,605.44	100.57 1.87%	257,463.81 2,525.87	0.89% 4,858.37	Aaa / AA+ NR	1.09 1.06
06406FAD5	Bank of NY Mellon Corp Callable Note Cont 6/16/2023 2.2% Due 8/16/2023	350,000.00	09/12/2019 2.15%	350,616.00 350,616.00	99.92 2.26%	349,705.30 962.50	1.20% (910.70)	A1 / A AA-	1.38 1.34
69371RR24	Paccar Financial Corp Note 0.35% Due 2/2/2024	210,000.00	01/28/2021 0.39%	209,756.40 209,756.40	96.38 2.38%	202,398.21 120.46	0.70% (7,358.19)	A1 / A+ NR	1.84 1.81
89114QCQ9	Toronto Dominion Bank Note 0.55% Due 3/4/2024	250,000.00	05/12/2021 0.53%	250,125.00 250,125.00	96.30 2.53%	240,749.50 103.13	0.83% (9,375.50)	A1 / A AA-	1.93 1.89
808513BN4	Charles Schwab Corp Callable Note Cont 2/18/2024 0.75% Due 3/18/2024	300,000.00	Various 0.70%	300,409.70 300,409.70	96.75 2.46%	290,237.11 81.25	1.00% (10,172.59)	A2 / A A	1.97 1.93
023135BW5	Amazon.com Inc Note 0.45% Due 5/12/2024	350,000.00	Various 0.67%	348,107.95 348,107.95	96.43 2.19%	337,498.36 608.12	1.16% (10,609.59)	A1 / AA AA-	2.12 2.08
91324PEB4	United Health Group Inc Callable Note Cont 5/15/2022 0.55% Due 5/15/2024	125,000.00	11/08/2021 0.78%	124,282.50 124,282.50	95.87 2.56%	119,838.50 259.72	0.41% (4,444.00)	A3 / A+ A	2.13 2.08

Holdings Report

As of March 31, 2022



CUSIP	Security Description	Par Value/Units	Purchase Date Book Yield	Cost Value Book Value	Mkt Price Mkt YTM	Market Value Accrued Int.	% of Port. Gain/Loss	Moody/S&P Fitch	Maturity Duration
CORPORATE									
14913R2L0	Caterpillar Financial Service Note 0.45% Due 5/17/2024	340,000.00	05/10/2021 0.50%	339,544.40 339,544.40	95.73 2.52%	325,479.28 569.50	1.12% (14,065.12)	A2 / A A	2.13 2.09
06051GJY6	Bank of America Corp Callable Note Cont 6/14/2023 0.523% Due 6/14/2024	255,000.00	06/07/2021 0.58%	255,016.80 255,016.80	97.24 1.88%	247,965.32 396.39	0.85% (7,051.48)	A2 / A- AA-	2.21 2.17
06367TQW3	Bank of Montreal Note 0.625% Due 7/9/2024	300,000.00	09/10/2021 0.65%	299,757.00 299,757.00	95.11 2.86%	285,321.90 427.08	0.98% (14,435.10)	A2 / A- AA-	2.28 2.22
79466LAG9	Salesforce.com Inc Callable Note Cont 7/15/2022 0.625% Due 7/15/2024	55,000.00	06/29/2021 0.64%	54,971.95 54,971.95	95.83 2.51%	52,704.52 72.57	0.18% (2,267.43)	A2 / A+ NR	2.29 2.24
91159HHX1	US Bancorp Callable Note Cont 6/28/2024 2.4% Due 7/30/2024	300,000.00	11/09/2021 0.85%	312,465.00 312,465.00	99.43 2.65%	298,280.70 1,220.00	1.03% (14,184.30)	A2 / A+ A+	2.33 2.24
78015K7C2	Royal Bank of Canada Note 2.25% Due 11/1/2024	250,000.00	05/19/2021 0.73%	262,875.00 262,875.00	98.67 2.78%	246,687.25 2,343.75	0.85% (16,187.75)	A1 / A AA-	2.59 2.47
89236TJT3	Toyota Motor Credit Corp Note 1.45% Due 1/13/2025	240,000.00	01/10/2022 1.50%	239,678.40 239,678.40	96.45 2.78%	231,483.12 754.00	0.80% (8,195.28)	A1 / A+ A+	2.79 2.69
46647PBY1	JP Morgan Chase & Co Callable Note Cont 2/16/2024 0.563% Due 2/16/2025	185,000.00	02/09/2021 0.60%	185,000.00 185,000.00	95.63 2.18%	176,924.20 130.19	0.61% (8,075.80)	A2 / A- AA-	2.88 2.82
46647PCH7	JP Morgan Chase & Co Callable Note Cont 6/1/2024 0.824% Due 6/1/2025	280,000.00	05/24/2021 0.79%	280,364.50 280,364.50	95.43 2.33%	267,214.93 769.07	0.92% (13,149.57)	A2 / A- AA-	3.17 3.09
438516CB0	Honeywell Intl Callable Note Cont 5/1/2025 1.35% Due 6/1/2025	300,000.00	03/09/2022 2.31%	291,084.00 291,084.00	96.40 2.54%	289,201.80 1,350.00	1.00% (1,882.20)	A2 / A A	3.17 3.06
857477BR3	State Street Bank Callable Note Cont 2/6/2025 1.746% Due 2/6/2026	340,000.00	Various 2.51%	331,375.00 331,375.00	96.44 2.80%	327,881.72 890.46	1.13% (3,493.28)	A1 / A AA-	3.86 3.67
Total Corporate		5,786,000.00	1.46%	5,782,638.54	2.16%	5,651,354.73 23,306.98	19.48% (131,283.81)	A1 / A A+	1.95 1.89

Holdings Report

As of March 31, 2022



CUSIP	Security Description	Par Value/Units	Purchase Date Book Yield	Cost Value Book Value	Mkt Price Mkt YTM	Market Value Accrued Int.	% of Port. Gain/Loss	Moody/S&P Fitch	Maturity Duration
MONEY MARKET FUND									
31846V203	First American Govt Obligation Fund Class Y	671,448.78	Various 0.01%	671,448.78 671,448.78	1.00 0.01%	671,448.78 0.00	2.30% 0.00	Aaa / AAA AAA	0.00 0.00
Total Money Market Fund		671,448.78	0.01%	671,448.78	0.01%	671,448.78	2.30%	Aaa / AAA	0.00
SUPRANATIONAL									
459058JM6	Intl. Bank Recon & Development Note 0.25% Due 11/24/2023	190,000.00	11/17/2020 0.32%	189,591.50 189,591.50	96.82 2.22%	183,967.31 167.57	0.63% (5,624.19)	Aaa / AAA AAA	1.65 1.63
4581X0DZ8	Inter-American Dev Bank Note 0.5% Due 9/23/2024	435,000.00	09/15/2021 0.52%	434,678.10 434,678.10	95.31 2.46%	414,585.45 48.33	1.42% (20,092.65)	Aaa / AAA NR	2.48 2.43
Total Supranational		625,000.00	0.46%	624,269.60	2.39%	598,552.76	2.06%	Aaa / AAA	2.23
US TREASURY									
912796S59	US Treasury Bill 0.741% Due 7/28/2022	500,000.00	03/31/2022 0.75%	498,776.12 498,786.40	99.76 0.75%	498,786.40 0.00	1.71% 0.00	P-1 / A-1+ F-1+	0.33 0.32
912828M80	US Treasury Note 2% Due 11/30/2022	350,000.00	11/27/2019 1.61%	353,992.19 353,992.19	100.45 1.31%	351,585.85 2,346.15	1.21% (2,406.34)	Aaa / AA+ AAA	0.67 0.66
91282CBA8	US Treasury Note 0.125% Due 12/15/2023	550,000.00	01/08/2021 0.22%	548,474.61 548,474.61	96.53 2.21%	530,900.15 202.09	1.82% (17,574.46)	Aaa / AA+ AAA	1.71 1.69
91282CBE0	US Treasury Note 0.125% Due 1/15/2024	500,000.00	01/12/2021 0.24%	498,222.66 498,222.66	96.28 2.26%	481,386.50 131.22	1.65% (16,836.16)	Aaa / AA+ AAA	1.79 1.77
91282CBR1	US Treasury Note 0.25% Due 3/15/2024	400,000.00	03/30/2021 0.33%	399,109.38 399,109.38	96.13 2.29%	384,500.00 46.20	1.32% (14,609.38)	Aaa / AA+ AAA	1.96 1.93
91282CBV2	US Treasury Note 0.375% Due 4/15/2024	475,000.00	04/23/2021 0.32%	475,797.85 475,797.85	96.12 2.33%	456,575.23 822.12	1.57% (19,222.62)	Aaa / AA+ AAA	2.04 2.01
91282CCC3	US Treasury Note 0.25% Due 5/15/2024	500,000.00	05/19/2021 0.35%	498,574.22 498,574.22	95.65 2.36%	478,261.50 473.07	1.64% (20,312.72)	Aaa / AA+ AAA	2.13 2.09

Holdings Report

As of March 31, 2022



CUSIP	Security Description	Par Value/Units	Purchase Date Book Yield	Cost Value Book Value	Mkt Price Mkt YTM	Market Value Accrued Int.	% of Port. Gain/Loss	Moody/S&P Fitch	Maturity Duration
US TREASURY									
91282CCG4	US Treasury Note 0.25% Due 6/15/2024	500,000.00	06/28/2021 0.46%	496,914.06 496,914.06	95.44 2.38%	477,207.00 367.45	1.64% (19,707.06)	Aaa / AA+ AAA	2.21 2.18
91282CCL3	US Treasury Note 0.375% Due 7/15/2024	600,000.00	08/05/2021 0.37%	600,164.06 600,164.06	95.52 2.39%	573,117.00 472.38	1.97% (27,047.06)	Aaa / AA+ AAA	2.29 2.26
91282CCT6	US Treasury Note 0.375% Due 8/15/2024	275,000.00	08/26/2021 0.46%	274,344.73 274,344.73	95.30 2.42%	262,087.93 128.19	0.90% (12,256.80)	Aaa / AA+ AAA	2.38 2.34
912828YE4	US Treasury Note 1.25% Due 8/31/2024	500,000.00	06/29/2021 0.50%	511,796.88 511,796.88	97.24 2.43%	486,211.00 543.48	1.67% (25,585.88)	Aaa / AA+ AAA	2.42 2.36
91282CCX7	US Treasury Note 0.375% Due 9/15/2024	550,000.00	09/10/2021 0.44%	548,925.78 548,925.78	95.09 2.45%	522,993.90 95.28	1.80% (25,931.88)	Aaa / AA+ AAA	2.46 2.42
91282CDB4	US Treasury Note 0.625% Due 10/15/2024	600,000.00	10/14/2021 0.63%	599,953.13 599,953.13	95.54 2.45%	573,234.60 1,730.77	1.97% (26,718.53)	Aaa / AA+ AAA	2.55 2.49
91282CDH1	US Treasury Note 0.75% Due 11/15/2024	500,000.00	11/29/2021 0.81%	499,082.03 499,082.03	95.66 2.47%	478,320.50 1,419.20	1.65% (20,761.53)	Aaa / AA+ AAA	2.63 2.56
91282CDN8	US Treasury Note 1% Due 12/15/2024	425,000.00	12/29/2021 0.99%	425,182.62 425,182.62	96.20 2.46%	408,830.03 1,249.31	1.41% (16,352.59)	Aaa / AA+ AAA	2.71 2.64
912828Z52	US Treasury Note 1.375% Due 1/31/2025	475,000.00	02/16/2021 0.37%	493,628.91 493,628.91	97.02 2.47%	460,824.10 1,082.53	1.59% (32,804.81)	Aaa / AA+ AAA	2.84 2.75
912828ZC7	US Treasury Note 1.125% Due 2/28/2025	600,000.00	03/28/2022 2.55%	576,070.31 576,070.31	96.22 2.48%	577,312.80 586.96	1.98% 1,242.49	Aaa / AA+ AAA	2.92 2.84
912828ZF0	US Treasury Note 0.5% Due 3/31/2025	500,000.00	03/03/2021 0.54%	499,257.81 499,257.81	94.30 2.48%	471,523.50 6.83	1.62% (27,734.31)	Aaa / AA+ AAA	3.00 2.94
912828ZL7	US Treasury Note 0.375% Due 4/30/2025	300,000.00	01/13/2021 0.39%	299,765.63 299,765.63	93.73 2.50%	281,191.50 472.38	0.97% (18,574.13)	Aaa / AA+ AAA	3.08 3.02
912828ZT0	US Treasury Note 0.25% Due 5/31/2025	600,000.00	10/05/2021 0.71%	590,132.81 590,132.81	93.16 2.51%	558,984.60 502.75	1.92% (31,148.21)	Aaa / AA+ AAA	3.17 3.11

Holdings Report

As of March 31, 2022



CUSIP	Security Description	Par Value/Units	Purchase Date Book Yield	Cost Value Book Value	Mkt Price Mkt YTM	Market Value Accrued Int.	% of Port. Gain/Loss	Moody/S&P Fitch	Maturity Duration
US TREASURY									
91282CAB7	US Treasury Note 0.25% Due 7/31/2025	500,000.00	03/22/2022 2.41%	465,312.50 465,312.50	92.81 2.51%	464,062.50 207.18	1.59% (1,250.00)	Aaa / AA+ AAA	3.34 3.28
Total US Treasury		10,200,000.00	0.74%	10,153,478.29 10,153,488.57	2.29%	9,777,896.59 12,885.54	33.61% (375,591.98)	Aaa / AA+ AAA	2.33 2.28
TOTAL PORTFOLIO		29,873,162.95	1.02%	29,780,356.28 29,780,390.39	2.05%	29,070,091.04 63,700.67	100.00% (710,299.35)	Aa1 / AA+ AAA	1.93 1.74
TOTAL MARKET VALUE PLUS ACCRUED						29,133,791.71			

Transaction Ledger

As of March 31, 2022



Transaction Type	Settlement Date	CUSIP	Quantity	Security Description	Price	Acq/Disp Yield	Amount	Interest Pur/Sold	Total Amount	Gain/Loss
ACQUISITIONS										
Purchase	03/01/2022	31846V203	0.25	First American Govt Obligation Fund Class Y	1.000	0.01%	0.25	0.00	0.25	0.00
Purchase	03/04/2022	31846V203	687.50	First American Govt Obligation Fund Class Y	1.000	0.01%	687.50	0.00	687.50	0.00
Purchase	03/06/2022	31846V203	3,987.50	First American Govt Obligation Fund Class Y	1.000	0.01%	3,987.50	0.00	3,987.50	0.00
Purchase	03/08/2022	3135G05X7	500,000.00	FNMA Note 0.375% Due 8/25/2025	95.312	1.78%	476,560.00	67.71	476,627.71	0.00
Purchase	03/08/2022	31846V203	127,085.61	First American Govt Obligation Fund Class Y	1.000	0.01%	127,085.61	0.00	127,085.61	0.00
Purchase	03/08/2022	31846V203	625.00	First American Govt Obligation Fund Class Y	1.000	0.01%	625.00	0.00	625.00	0.00
Purchase	03/10/2022	31846V203	604,459.82	First American Govt Obligation Fund Class Y	1.000	0.01%	604,459.82	0.00	604,459.82	0.00
Purchase	03/11/2022	438516CB0	300,000.00	Honeywell Intl Callable Note Cont 5/1/2025 1.35% Due 6/1/2025	97.028	2.31%	291,084.00	1,125.00	292,209.00	0.00
Purchase	03/15/2022	31846V203	1,531.25	First American Govt Obligation Fund Class Y	1.000	0.01%	1,531.25	0.00	1,531.25	0.00
Purchase	03/15/2022	31846V203	83.42	First American Govt Obligation Fund Class Y	1.000	0.01%	83.42	0.00	83.42	0.00
Purchase	03/15/2022	31846V203	40.08	First American Govt Obligation Fund Class Y	1.000	0.01%	40.08	0.00	40.08	0.00
Purchase	03/15/2022	31846V203	50.29	First American Govt Obligation Fund Class Y	1.000	0.01%	50.29	0.00	50.29	0.00
Purchase	03/15/2022	31846V203	43.33	First American Govt Obligation Fund Class Y	1.000	0.01%	43.33	0.00	43.33	0.00
Purchase	03/15/2022	31846V203	28.50	First American Govt Obligation Fund Class Y	1.000	0.01%	28.50	0.00	28.50	0.00
Purchase	03/15/2022	31846V203	49.83	First American Govt Obligation Fund Class Y	1.000	0.01%	49.83	0.00	49.83	0.00
Purchase	03/15/2022	31846V203	5,999.72	First American Govt Obligation Fund Class Y	1.000	0.01%	5,999.72	0.00	5,999.72	0.00

Transaction Ledger

As of March 31, 2022



Transaction Type	Settlement Date	CUSIP	Quantity	Security Description	Price	Acq/Disp Yield	Amount	Interest Pur/Sold	Total Amount	Gain/Loss
ACQUISITIONS										
Purchase	03/15/2022	31846V203	8,239.15	First American Govt Obligation Fund Class Y	1.000	0.01%	8,239.15	0.00	8,239.15	0.00
Purchase	03/15/2022	31846V203	10,667.90	First American Govt Obligation Fund Class Y	1.000	0.01%	10,667.90	0.00	10,667.90	0.00
Purchase	03/16/2022	31846V203	63.00	First American Govt Obligation Fund Class Y	1.000	0.01%	63.00	0.00	63.00	0.00
Purchase	03/16/2022	31846V203	39.67	First American Govt Obligation Fund Class Y	1.000	0.01%	39.67	0.00	39.67	0.00
Purchase	03/16/2022	448977AD0	200,000.00	Hyundai Auto Receivables Trust 2022-A A3 2.22% Due 10/15/2026	99.996	2.23%	199,992.30	0.00	199,992.30	0.00
Purchase	03/16/2022	47787JAC2	115,000.00	John Deere Owner Trust 2022-A A3 2.32% Due 9/16/2026	99.978	2.34%	114,974.56	0.00	114,974.56	0.00
Purchase	03/18/2022	31846V203	1,125.00	First American Govt Obligation Fund Class Y	1.000	0.01%	1,125.00	0.00	1,125.00	0.00
Purchase	03/18/2022	31846V203	61.50	First American Govt Obligation Fund Class Y	1.000	0.01%	61.50	0.00	61.50	0.00
Purchase	03/21/2022	31846V203	66.00	First American Govt Obligation Fund Class Y	1.000	0.01%	66.00	0.00	66.00	0.00
Purchase	03/21/2022	31846V203	14.63	First American Govt Obligation Fund Class Y	1.000	0.01%	14.63	0.00	14.63	0.00
Purchase	03/21/2022	31846V203	61.75	First American Govt Obligation Fund Class Y	1.000	0.01%	61.75	0.00	61.75	0.00
Purchase	03/21/2022	31846V203	12,800.05	First American Govt Obligation Fund Class Y	1.000	0.01%	12,800.05	0.00	12,800.05	0.00
Purchase	03/23/2022	31846V203	40,497.51	First American Govt Obligation Fund Class Y	1.000	0.01%	40,497.51	0.00	40,497.51	0.00
Purchase	03/23/2022	31846V203	1,087.50	First American Govt Obligation Fund Class Y	1.000	0.01%	1,087.50	0.00	1,087.50	0.00
Purchase	03/23/2022	91282CAB7	500,000.00	US Treasury Note 0.25% Due 7/31/2025	93.063	2.41%	465,312.50	176.10	465,488.60	0.00
Purchase	03/25/2022	31846V203	23.38	First American Govt Obligation Fund Class Y	1.000	0.01%	23.38	0.00	23.38	0.00

Transaction Ledger

As of March 31, 2022



Transaction Type	Settlement Date	CUSIP	Quantity	Security Description	Price	Acq/Disp Yield	Amount	Interest Pur/Sold	Total Amount	Gain/Loss
ACQUISITIONS										
Purchase	03/25/2022	31846V203	82.50	First American Govt Obligation Fund Class Y	1.000	0.01%	82.50	0.00	82.50	0.00
Purchase	03/29/2022	912828ZC7	600,000.00	US Treasury Note 1.125% Due 2/28/2025	96.012	2.55%	576,070.31	531.93	576,602.24	0.00
Purchase	03/30/2022	62479MJW4	300,000.00	MUFG Bank Ltd/NY Discount CP 1.43% Due 9/30/2022	99.269	1.46%	297,807.33	0.00	297,807.33	0.00
Purchase	03/30/2022	857477BR3	250,000.00	State Street Bank Callable Note Cont 2/6/2025 1.746% Due 2/6/2026	96.550	2.77%	241,375.00	642.62	242,017.62	0.00
Purchase	03/31/2022	31846V203	1,250.00	First American Govt Obligation Fund Class Y	1.000	0.01%	1,250.00	0.00	1,250.00	0.00
Purchase	03/31/2022	912796S59	500,000.00	US Treasury Bill 0.741% Due 7/28/2022	99.755	0.75%	498,776.12	0.00	498,776.12	0.00
Subtotal			4,085,751.64				3,982,703.76	2,543.36	3,985,247.12	0.00
Security Contribution	03/24/2022	31846V203	1,000,000.00	First American Govt Obligation Fund Class Y	1.000		1,000,000.00	0.00	1,000,000.00	0.00
Security Contribution	03/25/2022	31846V203	1,000,000.00	First American Govt Obligation Fund Class Y	1.000		1,000,000.00	0.00	1,000,000.00	0.00
Subtotal			2,000,000.00				2,000,000.00	0.00	2,000,000.00	0.00
TOTAL ACQUISITIONS			6,085,751.64				5,982,703.76	2,543.36	5,985,247.12	0.00
DISPOSITIONS										
Sale	03/08/2022	912828L24	600,000.00	US Treasury Note 1.875% Due 8/31/2022	100.578	0.66%	603,468.75	244.57	603,713.32	11,835.94
Sale	03/10/2022	912828R69	600,000.00	US Treasury Note 1.625% Due 5/31/2023	100.297	1.38%	601,781.25	2,678.57	604,459.82	17,718.75
Sale	03/11/2022	31846V203	292,209.00	First American Govt Obligation Fund Class Y	1.000	0.01%	292,209.00	0.00	292,209.00	0.00
Sale	03/16/2022	31846V203	199,992.30	First American Govt Obligation Fund Class Y	1.000	0.01%	199,992.30	0.00	199,992.30	0.00

Transaction Ledger

As of March 31, 2022



Transaction Type	Settlement Date	CUSIP	Quantity	Security Description	Price	Acq/Disp Yield	Amount	Interest Pur/Sold	Total Amount	Gain/Loss
DISPOSITIONS										
Sale	03/16/2022	31846V203	114,974.56	First American Govt Obligation Fund Class Y	1.000	0.01%	114,974.56	0.00	114,974.56	0.00
Sale	03/23/2022	3135G0T94	500,000.00	FNMA Note 2.375% Due 1/19/2023	100.775	1.42%	503,875.00	2,111.11	505,986.11	18,265.00
Sale	03/29/2022	31846V203	576,602.24	First American Govt Obligation Fund Class Y	1.000	0.01%	576,602.24	0.00	576,602.24	0.00
Sale	03/30/2022	31846V203	297,807.33	First American Govt Obligation Fund Class Y	1.000	0.01%	297,807.33	0.00	297,807.33	0.00
Sale	03/30/2022	31846V203	242,017.62	First American Govt Obligation Fund Class Y	1.000	0.01%	242,017.62	0.00	242,017.62	0.00
Sale	03/31/2022	31846V203	498,776.12	First American Govt Obligation Fund Class Y	1.000	0.01%	498,776.12	0.00	498,776.12	0.00
Subtotal			3,922,379.17				3,931,504.17	5,034.25	3,936,538.42	47,819.69
Paydown	03/15/2022	44935FAD6	0.00	Hyundai Auto Receivables Trust 2021-C A3 0.74% Due 5/15/2026	100.000		0.00	40.08	40.08	0.00
Paydown	03/15/2022	477870AC3	5,931.77	John Deere Owner Trust 2019-B A3 2.21% Due 12/15/2023	100.000		5,931.77	67.95	5,999.72	1.26
Paydown	03/15/2022	47788UAC6	0.00	John Deere Owner Trust 2021-A A3 0.36% Due 9/15/2025	100.000		0.00	28.50	28.50	0.00
Paydown	03/15/2022	47789KAC7	8,135.59	John Deere Owner Trust 2020-A A3 1.1% Due 8/15/2024	100.000		8,135.59	103.56	8,239.15	0.50
Paydown	03/15/2022	47789QAC4	0.00	John Deere Owner Trust 2021-B A3 0.52% Due 3/16/2026	100.000		0.00	49.83	49.83	0.00
Paydown	03/15/2022	58769KAD6	0.00	Mercedes-Benz Auto Lease Trust 2021-B A3 0.4% Due 11/15/2024	100.000		0.00	43.33	43.33	0.00
Paydown	03/15/2022	65479JAD5	10,477.64	Nissan Auto Receivables Owner 2019-C A3 1.93% Due 7/15/2024	100.000		10,477.64	190.26	10,667.90	0.55
Paydown	03/15/2022	89190GAC1	0.00	Toyota Auto Receivables Trust 2021-B A3 0.26% Due 11/17/2025	100.000		0.00	83.42	83.42	0.00

Transaction Ledger

As of March 31, 2022



Transaction Type	Settlement Date	CUSIP	Quantity	Security Description	Price	Acq/Disp Yield	Amount	Interest Pur/Sold	Total Amount	Gain/Loss
DISPOSITIONS										
Paydown	03/15/2022	89238JAC9	0.00	Toyota Auto Receivables Trust 2021-D A3 0.71% Due 4/15/2026	100.000		0.00	50.29	50.29	0.00
Paydown	03/16/2022	362554AC1	0.00	GM Financial Securitized Term 2021-4 A3 0.68% Due 9/16/2026	100.000		0.00	39.67	39.67	0.00
Paydown	03/16/2022	380146AC4	0.00	GM Financial Auto Receivables 2022-1 A3 1.26% Due 11/16/2026	100.000		0.00	63.00	63.00	0.00
Paydown	03/18/2022	43815EAC8	0.00	Honda Auto Receivables 2021-3 A3 0.41% Due 11/18/2025	100.000		0.00	61.50	61.50	0.00
Paydown	03/21/2022	36262XAC8	0.00	GM Financial Auto Lease Trust 2021-3 A2 0.39% Due 10/21/2024	100.000		0.00	61.75	61.75	0.00
Paydown	03/21/2022	43813GAC5	0.00	Honda Auto Receivables Trust 2021-1 A3 0.27% Due 4/21/2025	100.000		0.00	14.63	14.63	0.00
Paydown	03/21/2022	43813RAC1	12,585.82	Honda Auto Receivables 2020-1 A3 1.61% Due 4/22/2024	100.000		12,585.82	214.23	12,800.05	2.47
Paydown	03/21/2022	43815GAC3	0.00	Honda Auto Receivables Trust 2021-4 A3 0.88% Due 1/21/2026	100.000		0.00	66.00	66.00	0.00
Paydown	03/25/2022	05601XAC3	0.00	BMW Vehicle Lease Trust 2022-1 A3 1.1% Due 3/25/2025	100.000		0.00	82.50	82.50	0.00
Paydown	03/25/2022	09690AAC7	0.00	BMW Vehicle Lease Trust 2021-2 A3 0.33% Due 12/26/2024	100.000		0.00	23.38	23.38	0.00
Subtotal			37,130.82				37,130.82	1,283.88	38,414.70	4.78
Security Withdrawal	03/03/2022	31846V203	2,063.27	First American Govt Obligation Fund Class Y	1.000		2,063.27	0.00	2,063.27	0.00
Security Withdrawal	03/24/2022	31846V203	2,675.00	First American Govt Obligation Fund Class Y	1.000		2,675.00	0.00	2,675.00	0.00

Transaction Ledger

As of March 31, 2022



Transaction Type	Settlement Date	CUSIP	Quantity	Security Description	Price	Acq/Disp Yield	Amount	Interest Pur/Sold	Total Amount	Gain/Loss
DISPOSITIONS										
Security Withdrawal	03/25/2022	31846V203	223.30	First American Govt Obligation Fund Class Y	1.000		223.30	0.00	223.30	0.00
Subtotal			4,961.57				4,961.57	0.00	4,961.57	0.00
TOTAL DISPOSITIONS			3,964,471.56				3,973,596.56	6,318.13	3,979,914.69	47,824.47

OTHER TRANSACTIONS										
Interest	03/04/2022	89114QQC9	250,000.00	Toronto Dominion Bank Note 0.55% Due 3/4/2024	0.000		687.50	0.00	687.50	0.00
Interest	03/06/2022	3135G0W33	580,000.00	FNMA Note 1.375% Due 9/6/2022	0.000		3,987.50	0.00	3,987.50	0.00
Interest	03/08/2022	3137EAEW5	500,000.00	FHLMC Note 0.25% Due 9/8/2023	0.000		625.00	0.00	625.00	0.00
Interest	03/15/2022	91282CBR1	400,000.00	US Treasury Note 0.25% Due 3/15/2024	0.000		500.00	0.00	500.00	0.00
Interest	03/15/2022	91282CCX7	550,000.00	US Treasury Note 0.375% Due 9/15/2024	0.000		1,031.25	0.00	1,031.25	0.00
Interest	03/18/2022	808513BN4	300,000.00	Charles Schwab Corp Callable Note Cont 2/18/2024 0.75% Due 3/18/2024	0.000		1,125.00	0.00	1,125.00	0.00
Interest	03/23/2022	4581X0DZ8	435,000.00	Inter-American Dev Bank Note 0.5% Due 9/23/2024	0.000		1,087.50	0.00	1,087.50	0.00
Interest	03/31/2022	912828ZF0	500,000.00	US Treasury Note 0.5% Due 3/31/2025	0.000		1,250.00	0.00	1,250.00	0.00
Subtotal			3,515,000.00				10,293.75	0.00	10,293.75	0.00

Transaction Ledger

As of March 31, 2022



Transaction Type	Settlement Date	CUSIP	Quantity	Security Description	Price	Acq/Disp Yield	Amount	Interest Pur/Sold	Total Amount	Gain/Loss
OTHER TRANSACTIONS										
Dividend	03/01/2022	31846V203	78,037.88	First American Govt Obligation Fund Class Y	0.000		0.25	0.00	0.25	0.00
Subtotal			78,037.88				0.25	0.00	0.25	0.00
TOTAL OTHER TRANSACTIONS			3,593,037.88				10,294.00	0.00	10,294.00	0.00

Income Earned

As of March 31, 2022



CUSIP	Security Description	Trade Date Settle Date Units	Book Value: Begin Book Value: Acq Book Value: Disp Book Value: End	Prior Accrued Inc. Received Ending Accrued Total Interest	Accr. Of Discount Amort. Of Premium Net Accret/Amort Income Earned	Total Income
FIXED INCOME						
023135BW5	Amazon.com Inc Note 0.45% Due 05/12/2024	Various Various 350,000.00	348,107.95 0.00 0.00 348,107.95	476.88 0.00 608.12 131.24	0.00 0.00 0.00 131.24	131.24
037833AK6	Apple Inc Note 2.4% Due 05/03/2023	05/02/2019 05/06/2019 256,000.00	252,605.44 0.00 0.00 252,605.44	2,013.87 0.00 2,525.87 512.00	0.00 0.00 0.00 512.00	512.00
05601XAC3	BMW Vehicle Lease Trust 2022-1 A3 1.1% Due 03/25/2025	01/11/2022 01/19/2022 90,000.00	89,986.55 0.00 0.00 89,986.55	16.50 82.50 16.50 82.50	0.00 0.00 0.00 82.50	82.50
06051GJY6	Bank of America Corp Callable Note Cont 6/14/2023 0.523% Due 06/14/2024	06/07/2021 06/14/2021 255,000.00	255,016.80 0.00 0.00 255,016.80	285.26 0.00 396.39 111.13	0.00 0.00 0.00 111.13	111.13
06367TQW3	Bank of Montreal Note 0.625% Due 07/09/2024	09/10/2021 09/14/2021 300,000.00	299,757.00 0.00 0.00 299,757.00	270.83 0.00 427.08 156.25	0.00 0.00 0.00 156.25	156.25
06406FAD5	Bank of NY Mellon Corp Callable Note Cont 6/16/2023 2.2% Due 08/16/2023	09/12/2019 09/16/2019 350,000.00	350,616.00 0.00 0.00 350,616.00	320.83 0.00 962.50 641.67	0.00 0.00 0.00 641.67	641.67
084664BT7	Berkshire Hathaway Note 3% Due 05/15/2022	12/11/2018 12/13/2018 350,000.00	346,510.50 0.00 0.00 346,510.50	3,091.67 0.00 3,966.67 875.00	0.00 0.00 0.00 875.00	875.00
09690AAC7	BMW Vehicle Lease Trust 2021-2 A3 0.33% Due 12/26/2024	09/08/2021 09/15/2021 85,000.00	84,991.23 0.00 0.00 84,991.23	4.68 23.38 4.68 23.38	0.00 0.00 0.00 23.38	23.38
14913R2L0	Caterpillar Financial Service Note 0.45% Due 05/17/2024	05/10/2021 05/17/2021 340,000.00	339,544.40 0.00 0.00 339,544.40	442.00 0.00 569.50 127.50	0.00 0.00 0.00 127.50	127.50

Income Earned

As of March 31, 2022



CUSIP	Security Description	Trade Date Settle Date Units	Book Value: Begin Book Value: Acq Book Value: Disp Book Value: End	Prior Accrued Inc. Received Ending Accrued Total Interest	Accr. Of Discount Amort. Of Premium Net Accret/Amort Income Earned	Total Income
24422EUA5	John Deere Capital Corp Note 2.7% Due 01/06/2023	10/29/2019 10/31/2019 350,000.00	357,889.00 0.00 0.00 357,889.00	1,443.75 0.00 2,231.25 787.50	0.00 0.00 0.00 787.50	787.50
3130AFE78	FHLB Note 3% Due 12/09/2022	12/20/2018 12/21/2018 600,000.00	605,208.00 0.00 0.00 605,208.00	4,100.00 0.00 5,600.00 1,500.00	0.00 0.00 0.00 1,500.00	1,500.00
3130AQF40	FHLB Note 1% Due 12/20/2024	12/21/2021 12/22/2021 400,000.00	399,648.00 0.00 0.00 399,648.00	766.67 0.00 1,100.00 333.33	0.00 0.00 0.00 333.33	333.33
313379Q69	FHLB Note 2.125% Due 06/10/2022	06/06/2018 06/07/2018 500,000.00	487,020.50 0.00 0.00 487,020.50	2,390.63 0.00 3,276.04 885.41	0.00 0.00 0.00 885.41	885.41
3133834G3	FHLB Note 2.125% Due 06/09/2023	06/10/2019 06/11/2019 700,000.00	703,318.00 0.00 0.00 703,318.00	3,388.19 0.00 4,627.78 1,239.59	0.00 0.00 0.00 1,239.59	1,239.59
3133EKS7	FFCB Note 1.77% Due 06/26/2023	06/21/2019 06/26/2019 500,000.00	497,675.00 0.00 0.00 497,675.00	1,597.92 0.00 2,335.42 737.50	0.00 0.00 0.00 737.50	737.50
3133EKUA2	FFCB Note 1.85% Due 02/01/2023	07/23/2019 07/24/2019 600,000.00	599,850.00 0.00 0.00 599,850.00	925.00 0.00 1,850.00 925.00	0.00 0.00 0.00 925.00	925.00
3133EKY91	FFCB Note 1.375% Due 10/11/2022	10/08/2019 10/11/2019 500,000.00	498,715.00 0.00 0.00 498,715.00	2,673.61 0.00 3,246.53 572.92	0.00 0.00 0.00 572.92	572.92
3133EL3V4	FFCB Note 0.2% Due 08/14/2023	08/12/2020 08/14/2020 500,000.00	498,955.00 0.00 0.00 498,955.00	47.22 0.00 130.56 83.34	0.00 0.00 0.00 83.34	83.34

Income Earned

As of March 31, 2022



CUSIP	Security Description	Trade Date Settle Date Units	Book Value: Begin Book Value: Acq Book Value: Disp Book Value: End	Prior Accrued Inc. Received Ending Accrued Total Interest	Accr. Of Discount Amort. Of Premium Net Accret/Amort Income Earned	Total Income
3133ELNW0	FFCB Note 1.45% Due 02/21/2023	02/14/2020 02/21/2020 600,000.00	599,988.00 0.00 0.00 599,988.00	241.67 0.00 966.67 725.00	0.00 0.00 0.00 725.00	725.00
3133EMRZ7	FFCB Note 0.25% Due 02/26/2024	02/22/2021 02/26/2021 435,000.00	434,843.40 0.00 0.00 434,843.40	15.10 0.00 105.73 90.63	0.00 0.00 0.00 90.63	90.63
3133ENKS8	FFCB Note 1.125% Due 01/06/2025	01/06/2022 01/11/2022 205,000.00	204,538.75 0.00 0.00 204,538.75	320.31 0.00 512.50 192.19	0.00 0.00 0.00 192.19	192.19
3135G05G4	FNMA Note 0.25% Due 07/10/2023	07/08/2020 07/10/2020 520,000.00	518,882.00 0.00 0.00 518,882.00	184.17 0.00 292.50 108.33	0.00 0.00 0.00 108.33	108.33
3135G05X7	FNMA Note 0.375% Due 08/25/2025	03/07/2022 03/08/2022 500,000.00	0.00 476,560.00 0.00 476,560.00	0.00 (67.71) 187.50 119.79	0.00 0.00 0.00 119.79	119.79
3135G06H1	FNMA Note 0.25% Due 11/27/2023	11/23/2020 11/25/2020 465,000.00	464,469.90 0.00 0.00 464,469.90	303.54 0.00 400.42 96.88	0.00 0.00 0.00 96.88	96.88
3135G0T94	FNMA Note Due 01/19/2023	10/04/2018 10/05/2018 0.00	485,610.00 0.00 485,610.00 0.00	1,385.42 2,111.11 0.00 725.69	0.00 0.00 0.00 725.69	725.69
3135G0W33	FNMA Note 1.375% Due 09/06/2022	09/05/2019 09/06/2019 580,000.00	577,981.60 0.00 0.00 577,981.60	3,876.74 3,987.50 553.82 664.58	0.00 0.00 0.00 664.58	664.58
3137EAEV7	FHLMC Note 0.25% Due 08/24/2023	08/19/2020 08/21/2020 475,000.00	474,515.50 0.00 0.00 474,515.50	23.09 0.00 122.05 98.96	0.00 0.00 0.00 98.96	98.96

Income Earned

As of March 31, 2022



CUSIP	Security Description	Trade Date Settle Date Units	Book Value: Begin Book Value: Acq Book Value: Disp Book Value: End	Prior Accrued Inc. Received Ending Accrued Total Interest	Accr. Of Discount Amort. Of Premium Net Accret/Amort Income Earned	Total Income
3137EAEW5	FHLMC Note 0.25% Due 09/08/2023	09/29/2020 09/30/2020 500,000.00	500,310.00 0.00 0.00 500,310.00	600.69 625.00 79.86 104.17	0.00 0.00 0.00 104.17	104.17
3137EAEY1	FHLMC Note 0.125% Due 10/16/2023	10/29/2020 10/30/2020 400,000.00	398,596.00 0.00 0.00 398,596.00	187.50 0.00 229.17 41.67	0.00 0.00 0.00 41.67	41.67
3137EAEZ8	FHLMC Note 0.25% Due 11/06/2023	11/03/2020 11/05/2020 525,000.00	524,527.50 0.00 0.00 524,527.50	419.27 0.00 528.65 109.38	0.00 0.00 0.00 109.38	109.38
3137EAF2	FHLMC Note 0.25% Due 12/04/2023	12/02/2020 12/04/2020 375,000.00	374,628.75 0.00 0.00 374,628.75	226.56 0.00 304.69 78.13	0.00 0.00 0.00 78.13	78.13
362554AC1	GM Financial Securitized Term 2021-4 A3 0.68% Due 09/16/2026	10/13/2021 10/21/2021 70,000.00	69,998.22 0.00 0.00 69,998.22	19.83 39.67 19.83 39.67	0.00 0.00 0.00 39.67	39.67
36262XAC8	GM Financial Auto Lease Trust 2021-3 A2 0.39% Due 10/21/2024	08/10/2021 08/18/2021 190,000.00	189,997.42 0.00 0.00 189,997.42	22.64 61.75 22.64 61.75	0.00 0.00 0.00 61.75	61.75
380146AC4	GM Financial Auto Receivables 2022-1 A3 1.26% Due 11/16/2026	01/11/2022 01/19/2022 60,000.00	59,994.79 0.00 0.00 59,994.79	31.50 63.00 31.50 63.00	0.00 0.00 0.00 63.00	63.00
43813GAC5	Honda Auto Receivables Trust 2021-1 A3 0.27% Due 04/21/2025	02/17/2021 02/24/2021 65,000.00	64,998.81 0.00 0.00 64,998.81	4.88 14.63 4.88 14.63	0.00 0.00 0.00 14.63	14.63
43813RAC1	Honda Auto Receivables 2020-1 A3 1.61% Due 04/22/2024	02/19/2020 02/26/2020 147,092.20	159,646.72 0.00 12,583.35 147,063.37	71.41 214.23 65.78 208.60	0.00 0.00 0.00 208.60	208.60

Income Earned

As of March 31, 2022



CUSIP	Security Description	Trade Date Settle Date Units	Book Value: Begin Book Value: Acq Book Value: Disp Book Value: End	Prior Accrued Inc. Received Ending Accrued Total Interest	Accr. Of Discount Amort. Of Premium Net Accret/Amort Income Earned	Total Income
43815EAC8	Honda Auto Receivables 2021-3 A3 0.41% Due 11/18/2025	08/17/2021 08/25/2021 180,000.00	179,997.37 0.00 0.00 179,997.37	26.65 61.50 26.65 61.50	0.00 0.00 0.00 61.50	61.50
43815GAC3	Honda Auto Receivables Trust 2021-4 A3 0.88% Due 01/21/2026	11/16/2021 11/24/2021 90,000.00	89,981.03 0.00 0.00 89,981.03	22.00 66.00 22.00 66.00	0.00 0.00 0.00 66.00	66.00
438516CB0	Honeywell Intl Callable Note Cont 5/1/2025 1.35% Due 06/01/2025	03/09/2022 03/11/2022 300,000.00	0.00 291,084.00 0.00 291,084.00	0.00 (1,125.00) 1,350.00 225.00	0.00 0.00 0.00 225.00	225.00
448977AD0	Hyundai Auto Receivables Trust 2022-A A3 2.22% Due 10/15/2026	03/09/2022 03/16/2022 200,000.00	0.00 199,992.30 0.00 199,992.30	0.00 0.00 185.00 185.00	0.00 0.00 0.00 185.00	185.00
44935FAD6	Hyundai Auto Receivables Trust 2021-C A3 0.74% Due 05/15/2026	11/09/2021 11/17/2021 65,000.00	64,985.49 0.00 0.00 64,985.49	21.38 40.08 21.38 40.08	0.00 0.00 0.00 40.08	40.08
4581X0DZ8	Inter-American Dev Bank Note 0.5% Due 09/23/2024	09/15/2021 09/23/2021 435,000.00	434,678.10 0.00 0.00 434,678.10	954.58 1,087.50 48.33 181.25	0.00 0.00 0.00 181.25	181.25
459058JM6	Intl. Bank Recon & Development Note 0.25% Due 11/24/2023	11/17/2020 11/24/2020 190,000.00	189,591.50 0.00 0.00 189,591.50	127.99 0.00 167.57 39.58	0.00 0.00 0.00 39.58	39.58
46647PBY1	JP Morgan Chase & Co Callable Note Cont 2/16/2024 0.563% Due 02/16/2025	02/09/2021 02/16/2021 185,000.00	185,000.00 0.00 0.00 185,000.00	43.40 0.00 130.19 86.79	0.00 0.00 0.00 86.79	86.79
46647PCH7	JP Morgan Chase & Co Callable Note Cont 6/1/2024 0.824% Due 06/01/2025	05/24/2021 06/01/2021 280,000.00	280,364.50 0.00 0.00 280,364.50	576.80 0.00 769.07 192.27	0.00 0.00 0.00 192.27	192.27

Income Earned

As of March 31, 2022



CUSIP	Security Description	Trade Date Settle Date Units	Book Value: Begin Book Value: Acq Book Value: Disp Book Value: End	Prior Accrued Inc. Received Ending Accrued Total Interest	Accr. Of Discount Amort. Of Premium Net Accret/Amort Income Earned	Total Income
477870AC3	John Deere Owner Trust 2019-B A3 2.21% Due 12/15/2023	07/16/2019 07/24/2019 30,964.36	36,888.29 0.00 5,930.51 30,957.78	36.24 67.95 30.41 62.12	0.00 0.00 0.00 62.12	62.12
47787JAC2	John Deere Owner Trust 2022-A A3 2.32% Due 09/16/2026	03/10/2022 03/16/2022 115,000.00	0.00 114,974.56 0.00 114,974.56	0.00 0.00 111.17 111.17	0.00 0.00 0.00 111.17	111.17
47788UAC6	John Deere Owner Trust 2021-A A3 0.36% Due 09/15/2025	03/02/2021 03/10/2021 95,000.00	94,981.74 0.00 0.00 94,981.74	15.20 28.50 15.20 28.50	0.00 0.00 0.00 28.50	28.50
47789KAC7	John Deere Owner Trust 2020-A A3 1.1% Due 08/15/2024	03/04/2020 03/11/2020 104,840.68	112,969.37 0.00 8,135.09 104,834.28	55.23 103.56 51.26 99.59	0.00 0.00 0.00 99.59	99.59
47789QAC4	John Deere Owner Trust 2021-B A3 0.52% Due 03/16/2026	07/13/2021 07/21/2021 115,000.00	114,989.74 0.00 0.00 114,989.74	26.58 49.83 26.58 49.83	0.00 0.00 0.00 49.83	49.83
58769KAD6	Mercedes-Benz Auto Lease Trust 2021-B A3 0.4% Due 11/15/2024	06/22/2021 06/29/2021 130,000.00	129,990.19 0.00 0.00 129,990.19	23.11 43.33 23.11 43.33	0.00 0.00 0.00 43.33	43.33
65479JAD5	Nissan Auto Receivables Owner 2019-C A3 1.93% Due 07/15/2024	10/16/2019 10/23/2019 107,816.93	118,288.33 0.00 10,477.09 107,811.24	101.47 190.26 92.48 181.27	0.00 0.00 0.00 181.27	181.27
69371RR24	Paccar Financial Corp Note 0.35% Due 02/02/2024	01/28/2021 02/02/2021 210,000.00	209,756.40 0.00 0.00 209,756.40	59.21 0.00 120.46 61.25	0.00 0.00 0.00 61.25	61.25
78015K7C2	Royal Bank of Canada Note 2.25% Due 11/01/2024	05/19/2021 05/21/2021 250,000.00	262,875.00 0.00 0.00 262,875.00	1,875.00 0.00 2,343.75 468.75	0.00 0.00 0.00 468.75	468.75

Income Earned

As of March 31, 2022



CUSIP	Security Description	Trade Date Settle Date Units	Book Value: Begin Book Value: Acq Book Value: Disp Book Value: End	Prior Accrued Inc. Received Ending Accrued Total Interest	Accr. Of Discount Amort. Of Premium Net Accret/Amort Income Earned	Total Income
79466LAG9	Salesforce.com Inc Callable Note Cont 7/15/2022 0.625% Due 07/15/2024	06/29/2021 07/12/2021 55,000.00	54,971.95 0.00 0.00 54,971.95	43.92 0.00 72.57 28.65	0.00 0.00 0.00 28.65	28.65
808513BN4	Charles Schwab Corp Callable Note Cont 2/18/2024 0.75% Due 03/18/2024	Various Various 300,000.00	300,409.70 0.00 0.00 300,409.70	1,018.75 1,125.00 81.25 187.50	0.00 0.00 0.00 187.50	187.50
857477BR3	State Street Bank Callable Note Cont 2/6/2025 1.746% Due 02/06/2026	Various Various 340,000.00	90,000.00 241,375.00 0.00 331,375.00	104.76 (642.62) 890.46 143.08	0.00 0.00 0.00 143.08	143.08
89114QCQ9	Toronto Dominion Bank Note 0.55% Due 03/04/2024	05/12/2021 05/14/2021 250,000.00	250,125.00 0.00 0.00 250,125.00	676.04 687.50 103.13 114.59	0.00 0.00 0.00 114.59	114.59
89190GAC1	Toyota Auto Receivables Trust 2021-B A3 0.26% Due 11/17/2025	06/08/2021 06/14/2021 385,000.00	384,958.54 0.00 0.00 384,958.54	44.49 83.42 44.49 83.42	0.00 0.00 0.00 83.42	83.42
89236TJT3	Toyota Motor Credit Corp Note 1.45% Due 01/13/2025	01/10/2022 01/13/2022 240,000.00	239,678.40 0.00 0.00 239,678.40	464.00 0.00 754.00 290.00	0.00 0.00 0.00 290.00	290.00
89238JAC9	Toyota Auto Receivables Trust 2021-D A3 0.71% Due 04/15/2026	11/09/2021 11/15/2021 85,000.00	84,998.19 0.00 0.00 84,998.19	26.82 50.29 26.82 50.29	0.00 0.00 0.00 50.29	50.29
911312BC9	UPS Callable Note Cont 4/16/2022 2.35% Due 05/16/2022	04/10/2018 04/12/2018 400,000.00	390,204.00 0.00 0.00 390,204.00	2,741.67 0.00 3,525.00 783.33	0.00 0.00 0.00 783.33	783.33
91159HHX1	US Bancorp Callable Note Cont 6/28/2024 2.4% Due 07/30/2024	11/09/2021 11/12/2021 300,000.00	312,465.00 0.00 0.00 312,465.00	620.00 0.00 1,220.00 600.00	0.00 0.00 0.00 600.00	600.00

Income Earned

As of March 31, 2022



CUSIP	Security Description	Trade Date Settle Date Units	Book Value: Begin Book Value: Acq Book Value: Disp Book Value: End	Prior Accrued Inc. Received Ending Accrued Total Interest	Accr. Of Discount Amort. Of Premium Net Accret/Amort Income Earned	Total Income
912828L24	US Treasury Note Due 08/31/2022	04/08/2019 04/09/2019 0.00	591,632.81 0.00 591,632.81 0.00	30.57 244.57 0.00 214.00	0.00 0.00 0.00 214.00	214.00
912828M80	US Treasury Note 2% Due 11/30/2022	11/27/2019 11/29/2019 350,000.00	353,992.19 0.00 0.00 353,992.19	1,750.00 0.00 2,346.15 596.15	0.00 0.00 0.00 596.15	596.15
912828R69	US Treasury Note Due 05/31/2023	04/11/2019 04/15/2019 0.00	584,062.50 0.00 584,062.50 0.00	2,437.50 2,678.57 0.00 241.07	0.00 0.00 0.00 241.07	241.07
912828YE4	US Treasury Note 1.25% Due 08/31/2024	06/29/2021 06/30/2021 500,000.00	511,796.88 0.00 0.00 511,796.88	16.98 0.00 543.48 526.50	0.00 0.00 0.00 526.50	526.50
912828Z52	US Treasury Note 1.375% Due 01/31/2025	02/16/2021 02/17/2021 475,000.00	493,628.91 0.00 0.00 493,628.91	523.22 0.00 1,082.53 559.31	0.00 0.00 0.00 559.31	559.31
912828ZC7	US Treasury Note 1.125% Due 02/28/2025	03/28/2022 03/29/2022 600,000.00	0.00 576,070.31 0.00 576,070.31	0.00 (531.93) 586.96 55.03	0.00 0.00 0.00 55.03	55.03
912828ZF0	US Treasury Note 0.5% Due 03/31/2025	03/03/2021 03/04/2021 500,000.00	499,257.81 0.00 0.00 499,257.81	1,043.96 1,250.00 6.83 212.87	0.00 0.00 0.00 212.87	212.87
912828ZL7	US Treasury Note 0.375% Due 04/30/2025	01/13/2021 01/14/2021 300,000.00	299,765.63 0.00 0.00 299,765.63	376.04 0.00 472.38 96.34	0.00 0.00 0.00 96.34	96.34
912828ZT0	US Treasury Note 0.25% Due 05/31/2025	10/05/2021 10/06/2021 600,000.00	590,132.81 0.00 0.00 590,132.81	375.00 0.00 502.75 127.75	0.00 0.00 0.00 127.75	127.75

Income Earned

As of March 31, 2022



CUSIP	Security Description	Trade Date Settle Date Units	Book Value: Begin Book Value: Acq Book Value: Disp Book Value: End	Prior Accrued Inc. Received Ending Accrued Total Interest	Accr. Of Discount Amort. Of Premium Net Accret/Amort Income Earned	Total Income
91282CAB7	US Treasury Note 0.25% Due 07/31/2025	03/22/2022 03/23/2022 500,000.00	0.00 465,312.50 0.00 465,312.50	0.00 (176.10) 207.18 31.08	0.00 0.00 0.00 31.08	31.08
91282CBA8	US Treasury Note 0.125% Due 12/15/2023	01/08/2021 01/11/2021 550,000.00	548,474.61 0.00 0.00 548,474.61	143.54 0.00 202.09 58.55	0.00 0.00 0.00 58.55	58.55
91282CBE0	US Treasury Note 0.125% Due 01/15/2024	01/12/2021 01/15/2021 500,000.00	498,222.66 0.00 0.00 498,222.66	77.69 0.00 131.22 53.53	0.00 0.00 0.00 53.53	53.53
91282CBR1	US Treasury Note 0.25% Due 03/15/2024	03/30/2021 03/31/2021 400,000.00	399,109.38 0.00 0.00 399,109.38	461.33 500.00 46.20 84.87	0.00 0.00 0.00 84.87	84.87
91282CBV2	US Treasury Note 0.375% Due 04/15/2024	04/23/2021 04/26/2021 475,000.00	475,797.85 0.00 0.00 475,797.85	670.42 0.00 822.12 151.70	0.00 0.00 0.00 151.70	151.70
91282CCC3	US Treasury Note 0.25% Due 05/15/2024	05/19/2021 05/21/2021 500,000.00	498,574.22 0.00 0.00 498,574.22	366.02 0.00 473.07 107.05	0.00 0.00 0.00 107.05	107.05
91282CCG4	US Treasury Note 0.25% Due 06/15/2024	06/28/2021 06/29/2021 500,000.00	496,914.06 0.00 0.00 496,914.06	260.99 0.00 367.45 106.46	0.00 0.00 0.00 106.46	106.46
91282CCL3	US Treasury Note 0.375% Due 07/15/2024	08/05/2021 08/06/2021 600,000.00	600,164.06 0.00 0.00 600,164.06	279.70 0.00 472.38 192.68	0.00 0.00 0.00 192.68	192.68
91282CCT6	US Treasury Note 0.375% Due 08/15/2024	08/26/2021 08/27/2021 275,000.00	274,344.73 0.00 0.00 274,344.73	39.88 0.00 128.19 88.31	0.00 0.00 0.00 88.31	88.31

Income Earned

As of March 31, 2022



CUSIP	Security Description	Trade Date Settle Date Units	Book Value: Begin Book Value: Acq Book Value: Disp Book Value: End	Prior Accrued Inc. Received Ending Accrued Total Interest	Accr. Of Discount Amort. Of Premium Net Accret/Amort Income Earned	Total Income
91282CCX7	US Treasury Note 0.375% Due 09/15/2024	09/10/2021 09/15/2021 550,000.00	548,925.78 0.00 0.00 548,925.78	951.48 1,031.25 95.28 175.05	0.00 0.00 0.00 175.05	175.05
91282CDB4	US Treasury Note 0.625% Due 10/15/2024	10/14/2021 10/15/2021 600,000.00	599,953.13 0.00 0.00 599,953.13	1,411.40 0.00 1,730.77 319.37	0.00 0.00 0.00 319.37	319.37
91282CDH1	US Treasury Note 0.75% Due 11/15/2024	11/29/2021 11/30/2021 500,000.00	499,082.03 0.00 0.00 499,082.03	1,098.07 0.00 1,419.20 321.13	0.00 0.00 0.00 321.13	321.13
91282CDN8	US Treasury Note 1% Due 12/15/2024	12/29/2021 12/30/2021 425,000.00	425,182.62 0.00 0.00 425,182.62	887.36 0.00 1,249.31 361.95	0.00 0.00 0.00 361.95	361.95
91324PEB4	United Health Group Inc Callable Note Cont 5/15/2022 0.55% Due 05/15/2024	11/08/2021 11/10/2021 125,000.00	124,282.50 0.00 0.00 124,282.50	202.43 0.00 259.72 57.29	0.00 0.00 0.00 57.29	57.29
			27,645,386.73	55,298.70	0.00	
			2,365,368.67	14,068.52	0.00	
			1,698,431.35	63,700.67	0.00	
Total Fixed Income		28,401,714.17	28,312,324.05	22,470.49	22,470.49	22,470.49

CASH & EQUIVALENT						
31846V203	First American Govt Obligation Fund Class Y	Various Various 671,448.78	78,037.88 2,820,751.64 2,227,340.74 671,448.78	0.00 0.25 0.00 0.25	0.00 0.00 0.00 0.25	0.25
62479MJW4	MUFG Bank Ltd/NY Discount CP 1.43% Due 09/30/2022	03/30/2022 03/30/2022 300,000.00	0.00 297,807.33 0.00 297,831.16	0.00 0.00 0.00 0.00	23.83 0.00 23.83 23.83	23.83

Income Earned

As of March 31, 2022



CUSIP	Security Description	Trade Date Settle Date Units	Book Value: Begin Book Value: Acq Book Value: Disp Book Value: End	Prior Accrued Inc. Received Ending Accrued Total Interest	Accr. Of Discount Amort. Of Premium Net Accret/Amort Income Earned	Total Income
912796S59	US Treasury Bill 0.741% Due 07/28/2022	03/31/2022 03/31/2022 500,000.00	0.00 498,776.12 0.00 498,786.40	0.00 0.00 0.00 0.00	10.28 0.00 10.28 10.28	10.28
			78,037.88	0.00	34.11	
			3,617,335.09	0.25	0.00	
			2,227,340.74	0.00	34.11	
Total Cash & Equivalent		1,471,448.78	1,468,066.34	0.25	34.36	34.36
			27,723,424.61	55,298.70	34.11	
			5,982,703.76	14,068.77	0.00	
			3,925,772.09	63,700.67	34.11	
TOTAL PORTFOLIO		29,873,162.95	29,780,390.39	22,470.74	22,504.85	22,504.85

TRUSTED SOLUTIONS. LASTING RESULTS.

Monthly Account Report for the Period
03/01/2022 to 03/31/2022

CITY OF SOLANA BEACH
City of Solana Beach PARS PAPEBT

Plan Summary

Beginning Plan Value as of 03/01/2022	\$4,962,774.60
Change in Plan Value	\$(14,756.74)
Ending Plan Value as of 03/31/2022	\$4,948,017.86

Activity Summary by Source

Source	Balance on 03/01/2022	Contributions	Earnings	Expenses	Distributions	Transfers	Balance on 03/31/2022
OPEB	\$1,350,121.72	\$0.00	\$(3,353.33)	\$(661.24)	\$0.00	\$0.00	\$1,346,107.15
PENSION	\$3,612,652.88	\$0.00	\$(8,972.82)	\$(1,769.35)	\$0.00	\$0.00	\$3,601,910.71
Totals	\$4,962,774.60	\$0.00	\$(12,326.15)	\$(2,430.59)	\$0.00	\$0.00	\$4,948,017.86

Transactions for the Period

Source	Date	Description	Amount
OPEB	03/31/2022	ACCOUNT GAINS/(LOSSES)	\$(3,353.33)
OPEB	03/31/2022	ASSET MGMT FEES	\$(379.97)
OPEB	03/31/2022	TRUST ADMINISTRATOR FEES	\$(281.27)
PENSION	03/31/2022	ACCOUNT GAINS/(LOSSES)	\$(8,972.82)
PENSION	03/31/2022	ASSET MGMT FEES	\$(1,016.71)
PENSION	03/31/2022	TRUST ADMINISTRATOR FEES	\$(752.64)

Investment Selection

Source	Selected Investment
OPEB	HighMark PLUS Moderate
PENSION	HighMark PLUS Moderate

Investment Objective

Selected Investment	Description
HighMark PLUS Moderate	The dual goals of the Moderate Strategy are growth of principal and income. It is expected that dividend and interest income will comprise a significant portion of total return, although growth through capital appreciation is equally important. The portfolio will be allocated between equity and fixed income investments.

TRUSTED SOLUTIONS. LASTING RESULTS.

Monthly Account Report for the Period
03/01/2022 to 03/31/2022

CITY OF SOLANA BEACH
City of Solana Beach PARS PAPEBT

Investment Performance

Source	1-Month	3-Month	1-Year	Annualized Return			Inception Date
				3-Years	5-Years	10-Years	
OPEB	-0.25%	-4.96%	1.58%	8.05%	7.13%	-	03/01/2016
PENSION	-0.25%	-4.96%	1.58%	8.07%	7.17%	-	03/01/2016

Information as provided by US Bank, Trustee for PARS. Investments are NOT insured by the FDIC or by any other Federal Government Agency, are NOT Bank deposits, are NOT guaranteed by the Bank or any Bank affiliate, and MAY lose value, including possible loss of principal. Past performance does not guarantee future results. Account balances are inclusive of Trust Administration, Trustee and Investment Management fees if applicable. Performance returns may not reflect the deduction of applicable fees, which could reduce returns. Annualized Return is the return on an investment over a period other than one year multiplied or divided to give a comparable one-year return. Information is deemed reliable but may be subject to change. The plan's Rate of Return may differ from the rate of return in the above linked document. Reasons for the difference may include the timing of transactions into and out of the plan, the duration of time the plan's funds reside in the sweep account and differences in the methodology used to calculate performance.



STAFF REPORT

CITY OF SOLANA BEACH

TO: Honorable Mayor and City Councilmembers
FROM: Gregory Wade, City Manager
MEETING DATE: April 27, 2022
ORIGINATING DEPT: City Manager's Department
SUBJECT: **Solid Waste Rate Review – Consideration of Resolution 2022–037 Authorizing the City to Proceed with Proposition 218 Public Noticing and Majority Protest Voting Procedures**

BACKGROUND:

The City of Solana Beach (City) has a Franchise Agreement (Agreement) with EDCO Waste and Recycling Services (EDCO) to provide residential and commercial solid waste and recycling collection services. Under the terms of the Agreement, EDCO may request a rate review annually to adjust the amount charged for providing services. The Agreement contains specific language regarding the rate review methodology. Rates may only be increased due to tipping fee (landfill disposal) and cost of living (CPI) increases on the base rate. The City is a member of the Regional Solid Waste Association (RSWA) that regulates the tipping fee for its member agencies. The proposed tipping fee and CPI increases are reviewed and approved by RSWA before being submitted to the City. City Staff then reviews the rate tables submitted by EDCO and, if appropriate, brings the requests before the City Council for consideration.

This item is before City Council to consider approving Resolution 2022–037 authorizing the City to proceed with the proper Proposition 218 noticing and majority protest voting procedures including setting a Public Hearing to disclose any protest votes for the solid waste rate increases on June 22, 2022.

DISCUSSION:

EDCO has submitted a rate review adjustment request for Fiscal Year 2022/23. The CPI increased 5.069% for the period from December 2020 to December 2021. Under the current Agreement, any annual increase for CPI is to be capped at 4.0% Therefore,

COUNCIL ACTION:

only a 4.0% increase is applied to current rates after franchise fees, AB939 and disposal fees are deducted from the current gross rate. The tipping fee increased 5.0%, or from \$51.26 per ton (at the time of the last rate increase in 2021) to \$53.82 per ton. Therefore, the proposed rate for residential services would increase from \$26.48 to \$27.59 (not including the National Pollutant Discharge Elimination System 'NPDES' fee) and the commercial rate for the most common service (3-yard bin picked up 1 time per week) will increase from \$112.47 to \$117.56 (not including the NPDES fee).

In addition, to comply with SB 1383, the State's new organics recycling law, the City Council must consider an incremental increase in commercial organic collection rates that will vary for each customer, based upon service levels needed. The current commercial organics rate for a 65-gallon cart, serviced one time per week is \$90.96 per month. The proposed commercial organics rate for the same level of service would increase to \$94.60 per month.

The full rate review package can be found in Attachment 2 including the Commercial Commingled Organics rates proposed for the fiscal year. These requests must go through the Proposition 218 noticing requirements, which Staff and EDCO have initiated. Residential and commercial customers will receive notification through the mail on the proposed rate increases and will have a chance to submit a protest vote if they oppose. The vote outcome will be revealed during the Public Hearing at the City Council meeting on June 22, 2021.

CEQA COMPLIANCE STATEMENT:

Not a project as defined by CEQA.

FISCAL IMPACT:

There is no fiscal impact to the City for the Proposition 218 noticing. These costs are paid for by the customers and will be reflected as a separate line item on the first bill clearly identifying the charge as the Proposition 218 noticing fee.

WORK PLAN:

N/A

OPTIONS:

- Approve Staff recommendation
- Do not approve Staff recommendation
- Provide alternative direction to Staff

DEPARTMENT RECOMMENDATION:

Staff recommends that the City Council adopt Resolution 2022–037 setting the Solid Waste Rate Review Public Hearing protest vote for June 22, 2022.

CITY MANAGER’S RECOMMENDATION:

Approve Department Recommendation



Gregory Wade, City Manager

Attachments:

1. Resolution 2022–037
2. EDCO Rate Review Packet

RESOLUTION 2022-037

A RESOLUTION OF THE CITY COUNCIL OF THE CITY OF SOLANA BEACH, CALIFORNIA, ESTABLISHING A PUBLIC HEARING DATE TO DISCLOSE ANY PROTEST VOTES FOR THE PROPOSED FY 2022/2023 SOLID WASTE RATE INCREASES

WHEREAS, the City of Solana Beach (City) entered into a Franchise Agreement (Agreement) with EDCO Waste and Recycling Services (EDCO) to provide solid waste and recycling collection services; and

WHEREAS, under the terms of the Agreement, EDCO may request a rate review annually to adjust the amount charged for providing services; and

WHEREAS, EDCO has submitted a rate review adjustment request for Fiscal Year 2022/2023; and

WHEREAS, the rate review request must go through the proper Proposition 218 noticing requirements and majority protest proceedings; and

WHEREAS, the protest hearing be conducted during a Public Hearing at a duly noticed City Council Meeting.

NOW, THEREFORE, the City Council of the City of Solana Beach, California, does resolve as follows:

1. That the above recitals are all true and correct.
2. That a Public Hearing be conducted to disclose any protest votes at the June 22, 2022 regularly scheduled City Council Meeting.

PASSED AND ADOPTED this 27th day of April, 2022, at a regular meeting of the City Council of the City of Solana Beach, California by the following vote:

AYES: Councilmembers –
NOES: Councilmembers –
ABSTAIN: Councilmembers –
ABSENT: Councilmembers –

LESA HEEBNER, Mayor

APPROVED AS TO FORM:

ATTEST:

JOHANNA N. CANLAS, City Attorney

ANGELA IVEY, City Clerk

EDCO

WASTE & RECYCLING SERVICES

Mr. Dan King
Assistant City Manager
City of Solana Beach
635 S. Highway 101
Solana Beach, CA 92075

March 17, 2022

Dear Dan:

The Franchise Agreement between the City of Solana Beach and EDCO allows for annual rate adjustments. Section 8.3 of the Agreement includes the details of the rate adjustment procedures. As outlined, rates may be increased due to changes in landfill tipping fees and increases in the Los Angeles-Anaheim Consumer Price Index (CPI). EDCO is requesting an allowable rate adjustment based on changes in the CPI and the Regional Solid Waste Association (RSWA) disposal fee. The effective date of this rate adjustment will be July 1, 2022.

CPI Adjustment

To calculate the CPI portion of the adjustment, the second half of the 2020 index (279.832) was compared to the second half of 2021 index (294.018) which produced a 14.186 point change or 5.069% increase. Under the current franchise agreement, any annual increase is to be capped at 4.0%. Therefore, only a **4.0%** increase is applied to current rates after franchise fees, AB939 and disposal fees are deducted from the current gross rate. A copy of the applicable CPI is attached for your reference.

RSWA Disposal Fee Adjustment

The City is a member of RSWA that regulates waste disposal tipping fees for its member agencies. Currently the tip fee for Solana Beach is \$51.26 per ton. Effective July 1, 2022, the tip fee for Solana Beach will increase to \$53.82, representing a 5.0% increase in the tip fee component of the rate calculation.

Rate Summary

The total fee adjustments as outlined above when applied will result in residential rates increasing from \$27.80 to \$28.91 per month, an increase of **\$1.11** per month per household for customers using a 96 Gallon Cart. Commercial rates for the most common service (a three cubic yard bin served once weekly) would increase from \$122.72 to \$127.81 or **\$5.09** per month. We propose to implement both residential and commercial rate changes on July 1, 2022.

Please feel free to review these adjustments and let me know if you have any questions or comments.

Sincerely,

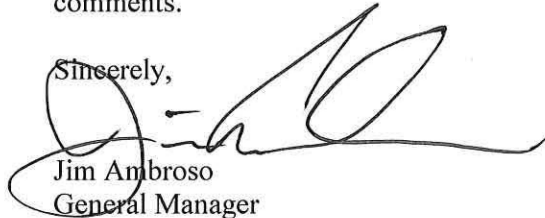

Jim Ambroso
General Manager

Attachments

"We'll Take Care of It"

224 S. Las Posas Road • San Marcos, California 92078

(760) 744-2700 • Fax: (760) 752-8339 • edcodisposal.com • Printed on Recycled Paper

City of Solana Beach
Multi-Family and Residential Rates
Effective July 1st, 2022

RSWA Tip Fee 2021	\$ 51.26
RSWA Tip Fee 2022	\$ 53.82
Change	\$ 2.56
% Change - Tip Fee	5.00%

CPI Consumer Price Index 12/31/2021	279.8
CPI Consumer Price Index 12/31/2022	294.0
Change	14.2
% Change - CPI	5.07%
Cap % 4%	

Description	Frequency per Week	Rates 7.1.2021							Rate Adjustments effective 7.1.22				Rates 7.1.2022						
		Net Operating Expense	Disposal Component	Franchise Fee 10.0%	Customer Total w/o NPDES		Customer Total with NPDES		4.00% Net Operating Expense	5.00% Disposal Component	Franchise Fee 10.0%	Customer Total w/o NPDES		Net Operating Expense	Disposal Component	Franchise Fee 10.0%	Customer Total w/o NPDES		Customer Total with NPDES
					NPDES	NPDES	NPDES	NPDES				NPDES	NPDES				NPDES	NPDES	
Residential Rates (Including Organics)																			
Solid Waste Service (1 cart)	96 gal	\$ 19.32	\$ 4.51	\$ 2.65	\$ 26.48	\$ 1.32	\$ 27.80	\$ 0.77	\$ 0.23	\$ 0.11	\$ 1.11	\$ 20.09	\$ 4.74	\$ 2.76	\$ 27.59	\$ 1.32	\$ 28.91		
	64 gal	\$ 19.32	\$ 4.51	\$ 2.65	\$ 26.48	\$ 0.88	\$ 27.36	\$ 0.77	\$ 0.23	\$ 0.11	\$ 1.11	\$ 20.09	\$ 4.74	\$ 2.76	\$ 27.59	\$ 0.88	\$ 28.47		
	35 gal	\$ 19.32	\$ 4.51	\$ 2.65	\$ 26.48	\$ 0.44	\$ 26.92	\$ 0.77	\$ 0.23	\$ 0.11	\$ 1.11	\$ 20.09	\$ 4.74	\$ 2.76	\$ 27.59	\$ 0.44	\$ 28.03		
Recycling Service (1 cart)	96 gal					\$ 1.32	\$ 1.32									\$ 1.32	\$ 1.32		
	64 gal					\$ 0.88	\$ 0.88									\$ 0.88	\$ 0.88		
	35 gal					\$ 0.44	\$ 0.44									\$ 0.44	\$ 0.44		
Extra Cart	96 gal	\$ 2.98	\$ -	\$ 0.33	\$ 3.31	\$ 1.32	\$ 4.63	\$ 0.12	\$ -	\$ 0.01	\$ 0.13	\$ 3.10	\$ -	\$ 0.34	\$ 3.44	\$ 1.32	\$ 4.76		
	64 gal	\$ 2.98	\$ -	\$ 0.33	\$ 3.31	\$ 0.88	\$ 4.19	\$ 0.12	\$ -	\$ 0.01	\$ 0.13	\$ 3.10	\$ -	\$ 0.34	\$ 3.44	\$ 0.88	\$ 4.32		
	35 gal	\$ 2.98	\$ -	\$ 0.33	\$ 3.31	\$ 0.44	\$ 3.75	\$ 0.12	\$ -	\$ 0.01	\$ 0.13	\$ 3.10	\$ -	\$ 0.34	\$ 3.44	\$ 0.44	\$ 3.88		

Rolloff Rates

Haul Rate	\$ 249.21	\$ -	\$ 27.69	\$ 276.90	\$ 276.90	\$ 9.97	\$ -	\$ 1.11	\$ 11.08	\$ 259.18	\$ -	\$ 28.80	\$ 287.98	\$ 287.98
Disposal Fee per Ton - Trash	\$ -	\$ 51.26	\$ 5.69	\$ 56.95	\$ 56.95	\$ -	\$ 2.56	\$ 0.28	\$ 2.84	\$ -	\$ 53.82	\$ 5.97	\$ 59.79	\$ 59.79
Disposal Fee per Ton - CDI (New)	\$ -	\$ 73.08	\$ 8.12	\$ 81.20	\$ 81.20	\$ -	\$ 8.92	\$ 0.99	\$ 9.91	\$ -	\$ 82.00	\$ 9.11	\$ 91.11	\$ 91.11

OTHER FEES:

Bin Exchange	\$ 39.82	\$ -	\$ 4.42	\$ 44.24	\$ 44.24	\$ 1.59	\$ -	\$ 0.18	\$ 1.77	\$ 41.41	\$ -	\$ 4.60	\$ 46.01	\$ 46.01
Lock Fees	\$ 8.45	\$ -	\$ 0.94	\$ 9.39	\$ 9.39	\$ 0.34	\$ -	\$ 0.04	\$ 0.38	\$ 8.79	\$ -	\$ 0.98	\$ 9.77	\$ 9.77
Pull Out Fees					\$ -									\$ -
16' - 50' per bin, per number of service days	\$ 3.84	\$ -	\$ 0.42	\$ 4.26	\$ 4.26	\$ 0.15	\$ -	\$ 0.02	\$ 0.17	\$ 3.99	\$ -	\$ 0.44	\$ 4.43	\$ 4.43
51' or more per bin, per number of service days	\$ 5.20	\$ -	\$ 0.58	\$ 5.78	\$ 5.78	\$ 0.21	\$ -	\$ 0.02	\$ 0.23	\$ 5.41	\$ -	\$ 0.60	\$ 6.01	\$ 6.01
Reinstate Fee:	\$ 24.89	\$ -	\$ 2.77	\$ 27.66	\$ 27.66	\$ 1.00	\$ -	\$ 0.11	\$ 1.11	\$ 25.89	\$ -	\$ 2.88	\$ 28.77	\$ 28.77
Late Fee: Minimum \$3 charge on any delinquent account	\$ 2.70	\$ -	\$ 0.30	\$ 3.00	\$ 3.00					\$ 2.70	\$ -	\$ 0.30	\$ 3.00	\$ 3.00
Bulky Items	\$ 27.95	\$ 9.41	\$ 4.15	\$ 41.51	\$ 41.51	\$ 1.12	\$ 0.47	\$ 0.18	\$ 1.77	\$ 29.07	\$ 9.88	\$ 4.33	\$ 43.28	\$ 43.28
Each Addtl Bulky Item	\$ 3.79	\$ 1.28	\$ 0.57	\$ 5.64	\$ 5.64	\$ 0.15	\$ 0.06	\$ 0.02	\$ 0.23	\$ 3.94	\$ 1.34	\$ 0.59	\$ 5.87	\$ 5.87
Recycling Contamination Fee	\$ 32.10	\$ 9.41	\$ 4.61	\$ 46.12	\$ 46.12	\$ 1.28	\$ 0.47	\$ 0.19	\$ 1.94	\$ 33.38	\$ 9.88	\$ 4.80	\$ 48.06	\$ 48.06
Overage Fee	\$ 32.00	\$ 9.41	\$ 4.60	\$ 46.01	\$ 46.01	\$ 1.28	\$ 0.47	\$ 0.19	\$ 1.94	\$ 33.28	\$ 9.88	\$ 4.79	\$ 47.95	\$ 47.95
Cart Delivery Fee	\$ 14.93	\$ -	\$ 1.66	\$ 16.59	\$ 16.59	\$ 0.60	\$ -	\$ 0.07	\$ 0.67	\$ 15.53	\$ -	\$ 1.73	\$ 17.26	\$ 17.26
Extra Pickup All Bin Sizes	\$ 37.43	\$ -	\$ 4.16	\$ 41.59	\$ 41.59	\$ 1.50	\$ -	\$ 0.17	\$ 1.67	\$ 38.93	\$ -	\$ 4.33	\$ 43.26	\$ 43.26

City of Solana Beach
Multi-Family and Residential Rates
Effective July 1st, 2022

RSWA Tip Fee 2021	\$ 51.26
RSWA Tip Fee 2022	\$ 53.82
Change	\$ 2.56
% Change - Tip Fee	5.00%

CPI Consumer Price Index 12/31/2021	279.8
CPI Consumer Price Index 12/31/2022	294.0
Change	14.2
% Change - CPI	5.07%
Cap % 4%	

Description	Frequency per Week	Rates 7.1.2021						Rate Adjustments effective 7.1.22				Rates 7.1.2022								
		Net Operating Expense	Disposal Component	Franchise Fee 10.0%	Customer Total w/o NPDES		Customer Total with NPDES		4.00% Net Operating Expense	5.00% Disposal Component	Franchise Fee 10.0%	Customer Total w/o NPDES		Net Operating Expense	Disposal Component	Franchise Fee 10.0%	Customer Total w/o NPDES		Customer Total with NPDES	
					NPDES	NPDES	NPDES	NPDES				NPDES	NPDES				NPDES	NPDES		
Commercial Multi-Family Rates																				
Commercial - Two Yard Bin																				
	1	\$ 37.82	\$ 28.10	\$ 7.32	\$ 73.24	\$ 5.56	\$ 78.80	\$ 1.51	\$	1.41	\$ 0.32	\$ 3.24	\$ 39.33	\$ 29.51	\$ 7.64	\$ 76.48	\$ 5.56	\$ 82.04		
	2	\$ 60.32	\$ 56.19	\$ 12.94	\$ 129.45	\$ 11.12	\$ 140.57	\$ 2.41	\$	2.81	\$ 0.58	\$ 5.80	\$ 62.73	\$ 59.00	\$ 13.52	\$ 135.25	\$ 11.12	\$ 146.37		
	3	\$ 66.07	\$ 84.29	\$ 16.71	\$ 167.07	\$ 16.68	\$ 183.75	\$ 2.64	\$	4.21	\$ 0.76	\$ 7.61	\$ 68.71	\$ 88.50	\$ 17.47	\$ 174.68	\$ 16.68	\$ 191.36		
	4	\$ 83.01	\$ 112.41	\$ 21.71	\$ 217.13	\$ 22.24	\$ 239.37	\$ 3.32	\$	5.62	\$ 0.99	\$ 9.93	\$ 86.33	\$ 118.03	\$ 22.70	\$ 227.06	\$ 22.24	\$ 249.30		
	5	\$ 99.86	\$ 140.50	\$ 26.71	\$ 267.07	\$ 27.80	\$ 294.87	\$ 3.99	\$	7.03	\$ 1.22	\$ 12.24	\$ 103.85	\$ 147.53	\$ 27.93	\$ 279.31	\$ 27.80	\$ 307.11		
Commercial - Three Yard Bin																				
	1	\$ 56.78	\$ 42.16	\$ 10.99	\$ 109.93	\$ 8.34	\$ 118.27	\$ 2.27	\$	2.11	\$ 0.49	\$ 4.87	\$ 59.05	\$ 44.27	\$ 11.48	\$ 114.80	\$ 8.34	\$ 123.14		
	2	\$ 92.25	\$ 84.29	\$ 19.62	\$ 196.16	\$ 16.68	\$ 212.84	\$ 3.69	\$	4.21	\$ 0.88	\$ 8.78	\$ 95.94	\$ 88.50	\$ 20.50	\$ 204.94	\$ 16.68	\$ 221.62		
	3	\$ 127.72	\$ 126.45	\$ 28.24	\$ 282.41	\$ 25.02	\$ 307.43	\$ 5.11	\$	6.32	\$ 1.27	\$ 12.70	\$ 132.83	\$ 132.77	\$ 29.51	\$ 295.11	\$ 25.02	\$ 320.13		
	4	\$ 163.13	\$ 168.60	\$ 36.85	\$ 368.58	\$ 33.36	\$ 401.94	\$ 6.53	\$	8.43	\$ 1.66	\$ 16.62	\$ 169.66	\$ 177.03	\$ 38.51	\$ 385.20	\$ 33.36	\$ 418.56		
	5	\$ 203.06	\$ 210.74	\$ 45.98	\$ 459.78	\$ 41.70	\$ 501.48	\$ 8.12	\$	10.54	\$ 2.07	\$ 20.73	\$ 211.18	\$ 221.28	\$ 48.05	\$ 480.51	\$ 41.70	\$ 522.21		
Commercial - Four Yard Bin																				
	1	\$ 70.15	\$ 56.19	\$ 14.04	\$ 140.38	\$ 11.12	\$ 151.50	\$ 2.81	\$	2.81	\$ 0.62	\$ 6.24	\$ 72.96	\$ 59.00	\$ 14.66	\$ 146.62	\$ 11.12	\$ 157.74		
	2	\$ 109.64	\$ 112.40	\$ 24.67	\$ 246.71	\$ 22.24	\$ 268.95	\$ 4.39	\$	5.62	\$ 1.11	\$ 11.12	\$ 114.03	\$ 118.02	\$ 25.78	\$ 257.83	\$ 22.24	\$ 280.07		
	3	\$ 149.09	\$ 168.60	\$ 35.30	\$ 352.99	\$ 33.36	\$ 386.35	\$ 5.96	\$	8.43	\$ 1.60	\$ 15.99	\$ 155.05	\$ 177.03	\$ 36.90	\$ 368.98	\$ 33.36	\$ 402.34		
	4	\$ 188.56	\$ 224.80	\$ 45.92	\$ 459.28	\$ 44.48	\$ 503.76	\$ 7.54	\$	11.24	\$ 2.09	\$ 20.87	\$ 196.10	\$ 236.04	\$ 48.01	\$ 480.15	\$ 44.48	\$ 524.63		
	5	\$ 227.70	\$ 280.99	\$ 56.53	\$ 565.22	\$ 55.60	\$ 620.82	\$ 9.11	\$	14.05	\$ 2.57	\$ 25.73	\$ 236.81	\$ 295.04	\$ 59.10	\$ 590.95	\$ 55.60	\$ 646.55		
Commercial - Five Yard Bin																				
	1	\$ 83.53	\$ 70.24	\$ 17.08	\$ 170.85	\$ 13.90	\$ 184.75	\$ 3.34	\$	3.51	\$ 0.76	\$ 7.61	\$ 86.87	\$ 73.75	\$ 17.84	\$ 178.46	\$ 13.90	\$ 192.36		
	2	\$ 128.70	\$ 140.50	\$ 29.91	\$ 299.11	\$ 27.80	\$ 326.91	\$ 5.15	\$	7.03	\$ 1.35	\$ 13.53	\$ 133.85	\$ 147.53	\$ 31.26	\$ 312.64	\$ 27.80	\$ 340.44		
	3	\$ 174.65	\$ 210.74	\$ 42.82	\$ 428.21	\$ 41.70	\$ 469.91	\$ 6.99	\$	10.54	\$ 1.95	\$ 19.48	\$ 181.64	\$ 221.28	\$ 44.77	\$ 447.69	\$ 41.70	\$ 489.39		
	4	\$ 218.95	\$ 280.99	\$ 55.55	\$ 555.49	\$ 55.60	\$ 611.09	\$ 8.76	\$	14.05	\$ 2.53	\$ 25.34	\$ 227.71	\$ 295.04	\$ 58.08	\$ 580.83	\$ 55.60	\$ 636.43		
	5	\$ 263.79	\$ 351.25	\$ 68.35	\$ 683.39	\$ 69.50	\$ 752.89	\$ 10.55	\$	17.56	\$ 3.12	\$ 31.23	\$ 274.34	\$ 368.81	\$ 71.47	\$ 714.62	\$ 69.50	\$ 784.12		
Muti Family Recycling Rate																				
	1	\$ 1.44	\$ -	\$ 0.16	\$ 1.60	\$ -	\$ 1.60	\$ 0.06	\$	-	\$ 0.01	\$ 0.07	\$ 1.50	\$ -	\$ 0.17	\$ 1.67	\$ -	\$ 1.67		
Commercial Can (1-Trash 1-Recy)																				
	1	\$ 24.39	\$ 14.05	\$ 4.27	\$ 42.71	\$ 3.52	\$ 46.23	\$ 0.98	\$	0.70	\$ 0.19	\$ 1.87	\$ 25.37	\$ 14.75	\$ 4.46	\$ 44.58	\$ 3.52	\$ 48.10		
	Extra Cart	\$ 1.78	\$ -	\$ 0.20	\$ 1.98	\$ 1.76	\$ 3.74	\$ 0.07	\$	-	\$ 0.01	\$ 0.08	\$ 1.85	\$ -	\$ 0.21	\$ 2.06	\$ 1.76	\$ 3.82		
	2	\$ 20.68	\$ 56.19	\$ 8.53	\$ 85.40	\$ 7.04	\$ 92.44	\$ 0.83	\$	2.81	\$ 0.40	\$ 4.04	\$ 21.51	\$ 59.00	\$ 8.93	\$ 89.44	\$ 7.04	\$ 96.48		
	Extra Cart	\$ 3.57	\$ -	\$ 0.40	\$ 3.97	\$ 3.52	\$ 7.49	\$ 0.14	\$	-	\$ 0.02	\$ 0.16	\$ 3.71	\$ -	\$ 0.42	\$ 4.13	\$ 3.52	\$ 7.65		
Multi-family Temp Bin(1 wk rental)																				
	1	\$ 45.78	\$ 42.16	\$ 9.78	\$ 97.72	\$ 8.34	\$ 106.06	\$ 1.83	\$	2.11	\$ 0.44	\$ 4.38	\$ 47.61	\$ 44.27	\$ 10.22	\$ 102.10	\$ 8.34	\$ 110.44		

City of Solana Beach
Commercial Rates
Effective July 1st, 2022

RSWA Tip Fee 2021	\$ 51.26
RSWA Tip Fee 2022	\$ 53.82
Change	\$ 2.56
% Change - Tip Fee	<u>5.00%</u>

CPI Consumer Price Index 12/31/2021	279.832
CPI Consumer Price Index 12/31/2022	<u>294.018</u>
Change	14.2
% Change - CPI	<u>5.07%</u>
Cap % 4%	

Description	Frequency per Week	Rates 7.1.2021						Rate Adjustments effective 7.1.22				Rates 7.1.2022					
		Net Operating Expense	Disposal Component	Franchise Fee 10.0%	Customer Total w/o NPDES	NPDES	Customer Total with NPDES	4.00% Net Operating Expense	5.00% Disposal Component	Franchise Fee 10.0%	Customer Total w/o NPDES	Net Operating Expense	Disposal Component	Franchise Fee 10.0%	Customer Total w/o NPDES	NPDES	Customer Total with NPDES
Commercial Rates																	
Commercial - Two Yard Bin																	
	1	\$ 31.94	\$ 35.71	\$ 7.52	\$ 75.17	\$ 6.83	\$ 82.00	\$ 1.28	\$ 1.78	\$ 0.34	\$ 3.40	\$ 33.22	\$ 37.49	\$ 7.86	\$ 78.57	\$ 6.83	\$ 85.40
	2	\$ 55.47	\$ 62.00	\$ 13.06	\$ 130.53	\$ 13.67	\$ 144.20	\$ 2.22	\$ 3.10	\$ 0.59	\$ 5.91	\$ 57.69	\$ 65.10	\$ 13.65	\$ 136.44	\$ 13.67	\$ 150.11
	3	\$ 78.86	\$ 88.14	\$ 18.55	\$ 185.55	\$ 20.50	\$ 206.05	\$ 3.15	\$ 4.40	\$ 0.84	\$ 8.39	\$ 82.01	\$ 92.54	\$ 19.39	\$ 193.94	\$ 20.50	\$ 214.44
	4	\$ 101.50	\$ 113.42	\$ 23.88	\$ 238.80	\$ 27.34	\$ 266.14	\$ 4.06	\$ 5.67	\$ 1.08	\$ 10.81	\$ 105.56	\$ 119.09	\$ 24.96	\$ 249.61	\$ 27.34	\$ 276.95
	5	\$ 125.61	\$ 140.37	\$ 29.55	\$ 295.53	\$ 34.17	\$ 329.70	\$ 5.02	\$ 7.01	\$ 1.34	\$ 13.37	\$ 130.63	\$ 147.38	\$ 30.89	\$ 308.90	\$ 34.17	\$ 343.07
	6	\$ 149.06	\$ 166.59	\$ 35.07	\$ 350.72	\$ 41.00	\$ 391.72	\$ 5.96	\$ 8.32	\$ 1.59	\$ 15.87	\$ 155.02	\$ 174.91	\$ 36.66	\$ 366.59	\$ 41.00	\$ 407.59
Commercial - Three Yard Bin																	
	1	\$ 47.79	\$ 53.42	\$ 11.26	\$ 112.47	\$ 10.25	\$ 122.72	\$ 1.91	\$ 2.67	\$ 0.51	\$ 5.09	\$ 49.70	\$ 56.09	\$ 11.77	\$ 117.56	\$ 10.25	\$ 127.81
	2	\$ 82.91	\$ 92.65	\$ 19.51	\$ 195.07	\$ 20.50	\$ 215.57	\$ 3.32	\$ 4.63	\$ 0.88	\$ 8.83	\$ 86.23	\$ 97.28	\$ 20.39	\$ 203.90	\$ 20.50	\$ 224.40
	3	\$ 119.07	\$ 133.07	\$ 28.02	\$ 280.16	\$ 30.75	\$ 310.91	\$ 4.76	\$ 6.65	\$ 1.27	\$ 12.68	\$ 123.83	\$ 139.72	\$ 29.29	\$ 292.84	\$ 30.75	\$ 323.59
	4	\$ 153.09	\$ 171.12	\$ 36.02	\$ 360.23	\$ 41.00	\$ 401.23	\$ 6.12	\$ 8.55	\$ 1.63	\$ 16.30	\$ 159.21	\$ 179.67	\$ 37.65	\$ 376.53	\$ 41.00	\$ 417.53
	5	\$ 188.13	\$ 210.26	\$ 44.27	\$ 442.66	\$ 51.26	\$ 493.92	\$ 7.53	\$ 10.50	\$ 2.00	\$ 20.03	\$ 195.66	\$ 220.76	\$ 46.27	\$ 462.69	\$ 51.26	\$ 513.95
	6	\$ 223.12	\$ 249.37	\$ 52.50	\$ 524.99	\$ 61.51	\$ 586.50	\$ 8.92	\$ 12.46	\$ 2.38	\$ 23.76	\$ 232.04	\$ 261.83	\$ 54.88	\$ 548.75	\$ 61.51	\$ 610.26
Commercial - Four Yard Bin																	
	1	\$ 63.54	\$ 71.02	\$ 14.94	\$ 149.50	\$ 13.67	\$ 163.17	\$ 2.54	\$ 3.55	\$ 0.68	\$ 6.77	\$ 66.08	\$ 74.57	\$ 15.62	\$ 156.27	\$ 13.67	\$ 169.94
	2	\$ 110.38	\$ 123.36	\$ 25.97	\$ 259.71	\$ 27.34	\$ 287.05	\$ 4.42	\$ 6.16	\$ 1.18	\$ 11.76	\$ 114.80	\$ 129.52	\$ 27.15	\$ 271.47	\$ 27.34	\$ 298.81
	3	\$ 157.21	\$ 175.71	\$ 36.99	\$ 369.91	\$ 41.00	\$ 410.91	\$ 6.29	\$ 8.78	\$ 1.67	\$ 16.74	\$ 163.50	\$ 184.49	\$ 38.66	\$ 386.65	\$ 41.00	\$ 427.65
	4	\$ 203.93	\$ 227.91	\$ 47.98	\$ 479.82	\$ 54.67	\$ 534.49	\$ 8.16	\$ 11.39	\$ 2.17	\$ 21.72	\$ 212.09	\$ 239.30	\$ 50.15	\$ 501.54	\$ 54.67	\$ 556.21
	5	\$ 250.68	\$ 280.15	\$ 58.98	\$ 589.81	\$ 68.34	\$ 658.15	\$ 10.03	\$ 14.00	\$ 2.67	\$ 26.70	\$ 260.71	\$ 294.15	\$ 61.65	\$ 616.51	\$ 68.34	\$ 684.85
	6	\$ 297.30	\$ 332.26	\$ 69.96	\$ 699.52	\$ 82.01	\$ 781.53	\$ 11.89	\$ 16.60	\$ 3.17	\$ 31.66	\$ 309.19	\$ 348.86	\$ 73.13	\$ 731.18	\$ 82.01	\$ 813.19
Commercial - Five Yard Bin																	
	1	\$ 79.26	\$ 88.58	\$ 18.65	\$ 186.49	\$ 17.09	\$ 203.58	\$ 3.17	\$ 4.43	\$ 0.84	\$ 8.44	\$ 82.43	\$ 93.01	\$ 19.49	\$ 194.93	\$ 17.09	\$ 212.02
	2	\$ 137.82	\$ 154.03	\$ 32.42	\$ 324.27	\$ 34.17	\$ 358.44	\$ 5.51	\$ 7.70	\$ 1.47	\$ 14.68	\$ 143.33	\$ 161.73	\$ 33.89	\$ 338.95	\$ 34.17	\$ 373.12
	3	\$ 196.35	\$ 219.43	\$ 46.20	\$ 461.98	\$ 51.26	\$ 513.24	\$ 7.85	\$ 10.96	\$ 2.09	\$ 20.90	\$ 204.20	\$ 230.39	\$ 48.29	\$ 482.88	\$ 51.26	\$ 534.14
	4	\$ 287.75	\$ 321.61	\$ 67.70	\$ 677.06	\$ 68.34	\$ 745.40	\$ 11.51	\$ 16.07	\$ 3.06	\$ 30.64	\$ 299.26	\$ 337.68	\$ 70.76	\$ 707.70	\$ 68.34	\$ 776.04
	5	\$ 313.23	\$ 350.07	\$ 73.70	\$ 737.00	\$ 85.43	\$ 822.43	\$ 12.53	\$ 17.49	\$ 3.34	\$ 33.36	\$ 325.76	\$ 367.56	\$ 77.04	\$ 770.36	\$ 85.43	\$ 855.79
	6	\$ 372.16	\$ 415.94	\$ 87.57	\$ 875.67	\$ 102.51	\$ 978.18	\$ 14.89	\$ 20.78	\$ 3.96	\$ 39.63	\$ 387.05	\$ 436.72	\$ 91.53	\$ 915.30	\$ 102.51	\$ 1,017.81

City of Solana Beach
Commercial Rates
Effective July 1st, 2022

RSWA Tip Fee 2021	\$ 51.26
RSWA Tip Fee 2022	\$ 53.82
Change	\$ 2.56
% Change - Tip Fee	<u>5.00%</u>

CPI Consumer Price Index 12/31/2021	279.832
CPI Consumer Price Index 12/31/2022	<u>294.018</u>
Change	<u>14.2</u>
% Change - CPI	<u>5.07%</u>
Cap % 4%	

Description	Frequency per Week	Rates 7.1.2021						Rate Adjustments effective 7.1.22				Rates 7.1.2022					
		Net Operating Expense	Disposal Component	Franchise Fee 10.0%	Customer Total w/o NPDES	NPDES	Customer Total with NPDES	4.00% Net Operating Expense	5.00% Disposal Component	Franchise Fee 10.0%	Customer Total w/o NPDES	Net Operating Expense	Disposal Component	Franchise Fee 10.0%	Customer Total w/o NPDES	NPDES	Customer Total with NPDES
Commercial Rates																	
Recycle - Two Yard Bin																	
	1	\$ 40.70	\$ -	\$ 4.52	\$ 45.22	\$ 6.83	\$ 52.05	\$ 1.63	\$ -	\$ 0.18	\$ 1.81	\$ 42.33	\$ -	\$ 4.70	\$ 47.03	\$ 6.83	\$ 53.86
	2	\$ 74.54	\$ -	\$ 8.29	\$ 82.83	\$ 13.67	\$ 96.50	\$ 2.98	\$ -	\$ 0.33	\$ 3.31	\$ 77.52	\$ -	\$ 8.62	\$ 86.14	\$ 13.67	\$ 99.81
	3	\$ 107.92	\$ -	\$ 11.99	\$ 119.91	\$ 20.50	\$ 140.41	\$ 4.32	\$ -	\$ 0.48	\$ 4.80	\$ 112.24	\$ -	\$ 12.47	\$ 124.71	\$ 20.50	\$ 145.21
	4	\$ 141.31	\$ -	\$ 15.71	\$ 157.02	\$ 27.34	\$ 184.36	\$ 5.65	\$ -	\$ 0.63	\$ 6.28	\$ 146.96	\$ -	\$ 16.34	\$ 163.30	\$ 27.34	\$ 190.64
	5	\$ 174.69	\$ -	\$ 19.42	\$ 194.11	\$ 34.17	\$ 228.28	\$ 6.99	\$ -	\$ 0.78	\$ 7.77	\$ 181.68	\$ -	\$ 20.20	\$ 201.88	\$ 34.17	\$ 236.05
Recycle - Three Yard Bin																	
	1	\$ 49.18	\$ -	\$ 5.46	\$ 54.64	\$ 10.25	\$ 64.89	\$ 1.97	\$ -	\$ 0.22	\$ 2.19	\$ 51.15	\$ -	\$ 5.68	\$ 56.83	\$ 10.25	\$ 67.08
	2	\$ 89.25	\$ -	\$ 9.91	\$ 99.16	\$ 20.50	\$ 119.66	\$ 3.57	\$ -	\$ 0.40	\$ 3.97	\$ 92.82	\$ -	\$ 10.31	\$ 103.13	\$ 20.50	\$ 123.63
	3	\$ 129.29	\$ -	\$ 14.38	\$ 143.67	\$ 30.75	\$ 174.42	\$ 5.17	\$ -	\$ 0.57	\$ 5.74	\$ 134.46	\$ -	\$ 14.95	\$ 149.41	\$ 30.75	\$ 180.16
	4	\$ 169.32	\$ -	\$ 18.83	\$ 188.15	\$ 41.00	\$ 229.15	\$ 6.77	\$ -	\$ 0.75	\$ 7.52	\$ 176.09	\$ -	\$ 19.58	\$ 195.67	\$ 41.00	\$ 236.67
	5	\$ 209.38	\$ -	\$ 23.27	\$ 232.65	\$ 51.26	\$ 283.91	\$ 8.38	\$ -	\$ 0.93	\$ 9.31	\$ 217.76	\$ -	\$ 24.20	\$ 241.96	\$ 51.26	\$ 293.22
Recycle - Four Yard Bin																	
	1	\$ 54.53	\$ -	\$ 6.06	\$ 60.59	\$ 13.67	\$ 74.26	\$ 2.18	\$ -	\$ 0.24	\$ 2.42	\$ 56.71	\$ -	\$ 6.30	\$ 63.01	\$ 13.67	\$ 76.68
	2	\$ 101.26	\$ -	\$ 11.24	\$ 112.50	\$ 27.34	\$ 139.84	\$ 4.05	\$ -	\$ 0.45	\$ 4.50	\$ 105.31	\$ -	\$ 11.69	\$ 117.00	\$ 27.34	\$ 144.34
	3	\$ 148.00	\$ -	\$ 16.44	\$ 164.44	\$ 41.00	\$ 205.44	\$ 5.92	\$ -	\$ 0.66	\$ 6.58	\$ 153.92	\$ -	\$ 17.10	\$ 171.02	\$ 41.00	\$ 212.02
	4	\$ 194.73	\$ -	\$ 21.63	\$ 216.36	\$ 54.67	\$ 271.03	\$ 7.79	\$ -	\$ 0.87	\$ 8.66	\$ 202.52	\$ -	\$ 22.50	\$ 225.02	\$ 54.67	\$ 279.69
	5	\$ 241.46	\$ -	\$ 26.83	\$ 268.29	\$ 68.34	\$ 336.63	\$ 9.66	\$ -	\$ 1.07	\$ 10.73	\$ 251.12	\$ -	\$ 27.90	\$ 279.02	\$ 68.34	\$ 347.36
Recycle - Five Yard Bin																	
	1	\$ 61.21	\$ -	\$ 6.80	\$ 68.01	\$ 17.09	\$ 85.10	\$ 2.45	\$ -	\$ 0.27	\$ 2.72	\$ 63.66	\$ -	\$ 7.07	\$ 70.73	\$ 17.09	\$ 87.82
	2	\$ 114.62	\$ -	\$ 12.73	\$ 127.35	\$ 34.17	\$ 161.52	\$ 4.58	\$ -	\$ 0.51	\$ 5.09	\$ 119.20	\$ -	\$ 13.24	\$ 132.44	\$ 34.17	\$ 166.61
	3	\$ 168.01	\$ -	\$ 18.66	\$ 186.67	\$ 51.26	\$ 237.93	\$ 6.72	\$ -	\$ 0.75	\$ 7.47	\$ 174.73	\$ -	\$ 19.41	\$ 194.14	\$ 51.26	\$ 245.40
	4	\$ 221.43	\$ -	\$ 24.60	\$ 246.03	\$ 68.34	\$ 314.37	\$ 8.86	\$ -	\$ 0.98	\$ 9.84	\$ 230.29	\$ -	\$ 25.58	\$ 255.87	\$ 68.34	\$ 324.21
	5	\$ 274.83	\$ -	\$ 30.53	\$ 305.36	\$ 85.43	\$ 390.79	\$ 10.99	\$ -	\$ 1.22	\$ 12.21	\$ 285.82	\$ -	\$ 31.75	\$ 317.57	\$ 85.43	\$ 403.00
Commercial Cardboard Recycling																	
2 - Yards																	
	1 x week	\$ 28.31	\$ -	\$ 3.14	\$ 31.45	\$ 6.83	\$ 38.28	\$ 1.13	\$ -	\$ 0.13	\$ 1.26	\$ 29.44	\$ -	\$ 3.27	\$ 32.71	\$ 6.83	\$ 39.54
3 - Yards																	
	1 x week	\$ 42.45	\$ -	\$ 4.71	\$ 47.16	\$ 10.25	\$ 57.41	\$ 1.70	\$ -	\$ 0.19	\$ 1.89	\$ 44.15	\$ -	\$ 4.90	\$ 49.05	\$ 10.25	\$ 59.30
4 - Yards																	
	1 x week	\$ 56.58	\$ -	\$ 6.30	\$ 62.88	\$ 13.67	\$ 76.55	\$ 2.26	\$ -	\$ 0.25	\$ 2.51	\$ 58.84	\$ -	\$ 6.55	\$ 65.39	\$ 13.67	\$ 79.06
5 - Yards																	
	1 x week	\$ 70.93	\$ -	\$ 7.88	\$ 78.81	\$ 17.09	\$ 95.90	\$ 2.84	\$ -	\$ 0.32	\$ 3.16	\$ 73.77	\$ -	\$ 8.20	\$ 81.97	\$ 17.09	\$ 99.06

City of Solana Beach
Commercial Rates
Effective July 1st, 2022

RSWA Tip Fee 2021	\$ 51.26
RSWA Tip Fee 2022	\$ 53.82
Change	\$ 2.56
% Change - Tip Fee	<u>5.00%</u>

CPI Consumer Price Index 12/31/2021	279.832
CPI Consumer Price Index 12/31/2022	<u>294.018</u>
Change	<u>14.2</u>
% Change - CPI	<u>5.07%</u>
Cap % 4%	

Description	Frequency per Week	Rates 7.1.2021					Rate Adjustments effective 7.1.22				Rates 7.1.2022						
		Net Operating Expense	Disposal Component	Franchise Fee 10.0%	Customer Total w/o NPDES	Customer Total with NPDES	4.00% Net Operating Expense	5.00% Disposal Component	Franchise Fee 10.0%	Customer Total w/o NPDES	Net Operating Expense	Disposal Component	Franchise Fee 10.0%	Customer Total w/o NPDES	Customer Total with NPDES		
Commercial Rates																	
OTHER FEES:																	
Bin Exchange		\$ 39.82	\$ -	\$ 4.42	\$ 44.24	\$ -	\$ 44.24	\$ 1.59	\$ -	\$ 0.18	\$ 1.77	\$ 41.41	\$ -	\$ 4.60	\$ 46.01	\$ -	\$ 46.01
Lock Fees		\$ 8.45	\$ -	\$ 0.94	\$ 9.39	\$ -	\$ 9.39	\$ 0.34	\$ -	\$ 0.04	\$ 0.38	\$ 8.79	\$ -	\$ 0.98	\$ 9.77	\$ -	\$ 9.77
Pull Out Fees																	
16' - 50' per bin, per number of service days		\$ 3.84	\$ -	\$ 0.42	\$ 4.26	\$ -	\$ 4.26	\$ 0.15	\$ -	\$ 0.02	\$ 0.17	\$ 3.99	\$ -	\$ 0.44	\$ 4.43	\$ -	\$ 4.43
51' or more per bin, per number of service day:		\$ 5.20	\$ -	\$ 0.58	\$ 5.78	\$ -	\$ 5.78	\$ 0.21	\$ -	\$ 0.02	\$ 0.23	\$ 5.41	\$ -	\$ 0.60	\$ 6.01	\$ -	\$ 6.01
Reinstate Fee:		\$ 24.89	\$ -	\$ 2.77	\$ 27.66	\$ -	\$ 27.66	\$ 1.00	\$ -	\$ 0.11	\$ 1.11	\$ 25.89	\$ -	\$ 2.88	\$ 28.77	\$ -	\$ 28.77
Late Fee: Minimum \$3 charge on any delinquent account		\$ 2.70	\$ -	\$ 0.30	\$ 3.00	\$ -	\$ 3.00					\$ 2.70	\$ -	\$ 0.30	\$ 3.00	\$ -	\$ 3.00
Bulky Items		\$ 27.95	\$ 9.41	\$ 4.15	\$ 41.51	\$ -	\$ 41.51	\$ 1.12	\$ 0.47	\$ 0.18	\$ 1.77	\$ 29.07	\$ 9.88	\$ 4.33	\$ 43.28	\$ -	\$ 43.28
Each Addtl Bulky Item		\$ 3.79	\$ 1.28	\$ 0.57	\$ 5.64	\$ -	\$ 5.64	\$ 0.15	\$ 0.06	\$ 0.02	\$ 0.23	\$ 3.94	\$ 1.34	\$ 0.59	\$ 5.87	\$ -	\$ 5.87
Recycling Contamination Fee		\$ 32.10	\$ 9.41	\$ 4.61	\$ 46.12	\$ -	\$ 46.12	\$ 1.28	\$ 0.47	\$ 0.19	\$ 1.94	\$ 33.38	\$ 9.88	\$ 4.80	\$ 48.06	\$ -	\$ 48.06
Overage Fee		\$ 32.00	\$ 9.41	\$ 4.60	\$ 46.01	\$ -	\$ 46.01	\$ 1.28	\$ 0.47	\$ 0.19	\$ 1.94	\$ 33.28	\$ 9.88	\$ 4.79	\$ 47.95	\$ -	\$ 47.95
Cart Delivery Fee		\$ 14.93	\$ -	\$ 1.66	\$ 16.59	\$ -	\$ 16.59	\$ 0.60	\$ -	\$ 0.07	\$ 0.67	\$ 15.53	\$ -	\$ 1.73	\$ 17.26	\$ -	\$ 17.26
Extra Pickup All Bin Sizes		\$ 37.43	\$ -	\$ 4.16	\$ 41.59	\$ -	\$ 41.59	\$ 1.50	\$ -	\$ 0.17	\$ 1.67	\$ 38.93	\$ -	\$ 4.33	\$ 43.26	\$ -	\$ 43.26

City of Solana Beach
Commercial Commingled Organics
Effective July 1st, 2022

CPI Consumer Price Index 12/31/2021	279.832
CPI Consumer Price Index 12/31/2022	<u>294.018</u>
Change	14.186
% Change - CPI	<u>5.069%</u>
Cap	<u>4.000%</u>

Current Rate Effective July 1st, 2021

Commercial Commingled Organics

1st Container

<u>Size</u>	<u>Frequency</u>			<u>Extra Pickup</u>
	<u>1</u>	<u>2</u>	<u>3</u>	
Cart (65 gl)	\$ 90.96	\$ 181.90	\$ 272.85	\$ 36.38
Cart (96 gl)	\$ 102.57	\$ 205.15	\$ 307.74	\$ 41.04
2 CY	\$ 166.36	\$ 332.73	\$ 499.08	\$ 66.54

Each Additional Container

<u>Size</u>	<u>Frequency</u>		
	<u>1</u>	<u>2</u>	<u>3</u>
Cart (65 gl)	\$ 86.40	\$ 172.81	\$ 259.20
Cart (96 gl)	\$ 97.45	\$ 194.90	\$ 292.35
2 CY	\$ 158.05	\$ 316.08	\$ 474.13

Proposed Rate Effective July 1st, 2022

Commercial Commingled Organics

1st Container

<u>Size</u>	<u>Frequency</u>			<u>Extra Pickup</u>	<u>% Incr</u>
	<u>1</u>	<u>2</u>	<u>3</u>		
Cart (65 gl)	\$ 94.60	\$ 189.18	\$ 283.76	\$ 37.84	4.00%
Cart (96 gl)	\$ 106.67	\$ 213.36	\$ 320.05	\$ 42.68	4.00%
2 CY	\$ 173.01	\$ 346.04	\$ 519.04	\$ 69.20	4.00%

Each Additional Container

<u>Size</u>	<u>Frequency</u>			<u>% Incr</u>
	<u>1</u>	<u>2</u>	<u>3</u>	
Cart (65 gl)	\$ 89.86	\$ 179.72	\$ 269.57	4.00%
Cart (96 gl)	\$ 101.35	\$ 202.70	\$ 304.04	4.00%
2 CY	\$ 164.37	\$ 328.72	\$ 493.10	4.00%

**CPI for All Urban Consumers (CPI-U)
Original Data Value**

Series Id: CUURS49ASA0

Not Seasonally Adjusted

Series: All items in Los Angeles-Long Beach-Anaheim,
Title: CA, all urban consumers, not seasonally
Area: Los Angeles-Long Beach-Anaheim, CA
Item: All items
Base: 1982-84=100
Period:
Years: 2012 to 2022

Year	Jan	Feb	Mar	Apr	May	Jun	Jul	Aug	Sep	Oct	Nov	Dec	Annual	HALF1	HALF2
2012	233.441	234.537	236.941	236.866	237.032	236.025	235.776	237.222	238.104	240.111	237.675	236.042	236.648	235.807	237.488
2013	238.015	239.753	239.995	239.043	239.346	239.223	238.920	239.219	239.611	239.940	238.677	238.742	239.207	239.229	239.185
2014	239.857	241.059	242.491	242.437	243.362	243.528	243.727	243.556	243.623	243.341	241.753	240.475	242.434	242.122	242.746
2015	239.724	241.297	243.738	243.569	246.093	245.459	247.066	246.328	245.431	245.812	245.711	245.357	244.632	243.313	245.951
2016	247.155	247.113	247.873	248.368	249.554	249.789	249.784	249.700	250.145	251.098	250.185	250.189	249.246	248.309	250.184
2017	252.373	253.815	254.525	254.971	255.674	255.275	256.023	256.739	257.890	258.883	259.135	259.220	256.210	254.439	257.982
2018	261.235	263.012	264.158	265.095	266.148	265.522	266.007	266.665	268.032	269.482	268.560	267.631	265.962	264.195	267.730
2019	269.468	269.608	271.311	273.945	274.479	274.380	274.682	274.579	276.054	278.075	277.239	275.553	274.114	272.199	276.030
2020	277.755	278.657	276.589	275.853	276.842	278.121	279.899	280.116	279.366	279.947	280.102	279.560	278.567	277.303	279.832
2021	280.178	281.347	282.648	285.808	287.620	289.218	290.890	291.333	292.209	294.961	296.790	297.925	289.244	284.470	294.018
2022	301.209														

CPI Index Change 14.186
CPI % Change 5.069%



Memo

To: James Eggart, General Manager- RSWA
From: Steve South, CEO- EDCO
Date: March 14th 2022
Re: RSWA Tip Fee Calculation for FY 2022/23 - Final

As specified in the disposal contract between our organizations, the following formula is used to calculate the RSWA tip fee for the upcoming fiscal year beginning July 1, 2022. Please refer to the attached spreadsheet for 2021 tonnage data and the Consumer Price Index used in the calculation.

The LA-Riverside-Orange County CPI for all Urban Consumers increased 6.57% from December 2020 to December 2021 and capped at 5.00%

- $2/3$ (or .6667) of the current tip fee increases by the change in the CPI Cap of 5.00%. $2/3 \times 5.00\% = 3.3335\%$.
- $1/3$ (or .3333) of the current tip fee changes by the difference between the capped CPI increase of 5.00% and the percentage change in solid waste tonnage generated by RSWA cities from the previous calendar year. In 2021, RSWA tonnage decreased -1.11% when compared to 2020 and therefore will be adjusted at the CPI cap rate of 5.00%
- $1/3$ (or .3333) of 5.00% = 1.6665%.
- The combined effect of the CPI (3.3335%) and the decreased tonnage calculation (1.6665%), results in an allowable increase of 5.0000% applied to the entire rate.

1. Del Mar, Encinitas, Solana Beach and Vista Tip Fee Calculation.

The current tip fee of \$51.26 per ton is increased 5.000% resulting in an increase of \$2.56 per ton. The new tip fee for these four cities on July 1, 2022 is \$53.82 per ton.

2. National City & Poway

The current tip fee in these two cities of \$46.22 is increased 5.000% resulting in an increase of \$2.31 per ton. The new tip fee for these cities on July 1, 2022 is \$48.53 per ton.

3. Volume Rebate Calculation

The current annual volume rebate of \$287,478.14 is multiplied by the CPI capped increase of 5.00%, which generates an additional \$14,373.91 in rebate revenue. The adjusted volume rebate is \$301,852.05. 1/3 of this amount (\$102,121.82), is adjusted by the percentage change in tonnage generated in 2021 compared to 2020, (-1.18%). Since the tonnage change is negative, it results in 0% change for this component of the rate. Therefore, the total volume rebate payable to RSWA beginning July 1, 2022 is \$301,852.05.

Please review these calculations at your earliest convenience so we may proceed with rate changes in all RSWA cities.

RSWA Annual Rate Adjustment effective 7/1/2022

<u>Tonnage</u>	<u>2020</u>	<u>2021</u>	Notes
Vista	87,771.01	88,140.02	
Encinitas	55,134.13	53,546.37	
Poway	48,571.14	46,414.13	
Solana Beach	10,136.76	9,199.05	
National City	38,174.54	39,104.11	
Del Mar- W.M.	5,996.39	6,475.25	
Solana Beach- W.M.	-	-	
Total Annual Disposal Tons	245,783.97	242,878.93	
Change in Tons YOY	-6,498.98	-2,905.04	
Actual % Change	-2.580%	-1.180%	
	1.500%	5.000%	If neg , use CPI (Cap 5% Floor 1.5%)

CPI

L.A.- Riverside-Anaheim CPI - Dec Prior	275.553	279.560	
L.A.- Riverside-Anaheim CPI - Dec Current	279.560	297.925	
Annual CPI Change - Actual	1.450%	6.570%	
Annual CPI Change - Adjusted	1.500%	5.000%	CPI Cap: 5% Floor: 1.5%

Adjustment To Volume Rebate to RSWA

CPI Cap: 5% Floor: 1.5%

(Exhibit C Example 6)

	<u>Volume. Rebate</u>	<u>Volume. Rebate</u>	
Prior Yr Vol Rebate	\$ 283,229.69	\$ 287,478.14	
CPI \$ Increase	\$ 4,248.45	\$ 14,373.91	CPI Cap: 5%
Sub-total	\$ 287,478.14	\$ 301,852.05	
divide by 3	\$ 95,826.05	\$ 100,617.35	
% Change in Tons	0.000%	0.000%	Use 0.00% Floor if neg. vol
\$ Change in Tons	\$ -	\$ -	
Adjusted Vol Rebate	\$ 287,478.14	\$ 301,852.05	
Volume Rebate to RSWA	\$ 287,478.14	\$ 301,852.05	
% Change	1.50%	5.00%	

Rate Increase Calculation**(Exhibit A Examples 6, 11)**

CPI	1.50%	5.000%	CPI Cap: 5%
X Two-Thirds	0.6667	0.6667	
CPI % increase to Rate	1.000%	3.3335%	
% Change in YOY Tons (Cap : 5%)	-2.580%	-1.180%	
CPI % Change	1.50%	5.00%	Use CPI if negative Vol
Difference	1.50%	5.000%	Use CPI if negative Vol
X One-Third	0.3333	0.3333	
% Tonnage Change in Rate	0.5000%	1.6665%	
Combined Increase in Rate %	1.5000%	5.0000%	

Del Mar, Encinitas, Solana Beach, Vista

Current Rate	\$ 50.50	\$ 51.26
Combined Increase in Rate %	1.5000%	5.0000%
Increase	\$ 0.7600	\$ 2.560
Adjusted Rate	\$ 51.26	\$ 53.82

National City, Poway

Current Rate	\$ 45.54	\$ 46.22
Combined Increase in Rate %	1.5000%	5.0000%
Increase	\$ 0.68	\$ 2.310
Adjusted Rate	\$ 46.22	\$ 48.53

CPI for All Urban Consumers (CPI-U)
Original Data Value

Series Id: CUURS49ASA0

Not Seasonally Adjusted

Series Title: All items in Los Angeles-Long Beach-Anaheim, CA, all urban consumers, not seasonally adjusted

Area: Los Angeles-Long Beach-Anaheim, CA

Item: All items

Base Period: 1982-84=100

Years: 2010 to 2021

 [xlsx](#)

Year	Jan	Feb	Mar	Apr	May	Jun	Jul	Aug	Sep	Oct	Nov	Dec	Annual	HALF1	HALF2
2011	228.652	229.729	232.241	233.319	233.367	232.328	231.303	231.833	233.022	233.049	232.731	231.567	231.928	231.606	232.251
2012	233.441	234.537	236.941	236.866	237.032	236.025	235.776	237.222	238.104	240.111	237.675	236.042	236.648	235.807	237.488
2013	238.015	239.753	239.995	239.043	239.346	239.223	238.920	239.219	239.611	239.940	238.677	238.742	239.207	239.229	239.185
2014	239.857	241.059	242.491	242.437	243.362	243.528	243.727	243.556	243.623	243.341	241.753	240.475	242.434	242.122	242.746
2015	239.724	241.297	243.738	243.569	246.093	245.459	247.066	246.328	245.431	245.812	245.711	245.357	244.632	243.313	245.951
2016	247.155	247.113	247.873	248.368	249.554	249.789	249.784	249.700	250.145	251.098	250.185	250.189	249.246	248.309	250.184
2017	252.373	253.815	254.525	254.971	255.674	255.275	256.023	256.739	257.890	258.883	259.135	259.220	256.210	254.439	257.982
2018	261.235	263.012	264.158	265.095	266.148	265.522	266.007	266.665	268.032	269.482	268.560	267.631	265.962	264.195	267.730
2019	269.468	269.608	271.311	273.945	274.479	274.380	274.682	274.579	276.054	278.075	277.239	275.553	274.114	272.199	276.030
2020	277.755	278.657	276.589	275.853	276.842	278.121	279.899	280.116	279.366	279.947	280.102	279.560	278.567	277.303	279.832
2021	280.178	281.347	282.648	285.808	287.620	289.218	290.890	291.333	292.209	294.961	296.790	297.925	289.244	284.470	294.018
												Change	18.3650		
												%	6.57%		



STAFF REPORT CITY OF SOLANA BEACH

TO: Honorable Mayor and City Councilmembers
FROM: Gregory Wade, City Manager
MEETING DATE: April 27, 2022
ORIGINATING DEPT: Community Development Department
SUBJECT: **Public Hearing: Request for a DRP to Construct a Split-Level, Single-Family Residence with a Detached Two-Story Garage, Detached Accessory Living Unit, and Perform Associated Site Improvements at 1246 Highland Drive. (Applicants: Brent and Leslie Stringer; Application: DRP21-005; APN: 298-370-38; Resolution No. 2022-031)**

BACKGROUND:

The Applicants, Brent and Leslie Stringer, are requesting City Council approval of a Development Review Permit (DRP) for the demolition and reconstruction of 982 square feet of the main level in the same footprint and the construction of a 721 square-foot addition to an existing 2,362 square foot split-level residence, legalize an existing unpermitted detached 552 square foot Accessory Dwelling Unit (ADU), and to perform associated site improvements at 1246 Highland Drive. The 28,749 square-foot lot is located within the Estate Residential (ER-2) Zone and the Dark Sky Area and is also developed with a detached, 1,176 square-foot, two-story garage/storage building and a 240 square foot, single-story storage building.

The project proposes grading in the amounts of approximately 180 yd³ of cut, 90 yd³ of fill, and 90 yd³ of export. The project requires a DRP for grading in excess of 100 cubic yards and for construction of a second level that exceeds 35% of the floor area of the first floor. The maximum proposed building height of the residence would not exceed 16 feet as measured from the pre-existing grade at 15 feet 4 inches (or 307.57 MSL); therefore, the project is exempt from the requirements of View Assessment/Structure Development Permit (SBMC Chapter 17.63).

The issue before the Council is whether to approve, approve with conditions, or deny the Applicants' request as contained in Resolution 2022-031 (Attachment 1).

CITY COUNCIL ACTION:

DISCUSSION:

The 28,749 square-foot property is located on the north side of Highland Drive. The property slopes upward approximately 35 feet as you move northeast diagonally across the lot. The existing residence is a split-level with a lower level on the southwest side of the property where the topography is lower and a main floor on top that extends to the northeast. There are three recorded easements on the lot 1) a private utility easement located across the northwest corner of the lot; 2) a private utility easement along the northeast property line; and 3) a private road, waterline easement, and private utility easement along the southwest property line.

In February 2021, a stop work notice was issued for the demolition of the northern 982 square feet of the existing residence, grading, and the construction of a retaining wall on the north and east sides of the flat pad where the existing structure was demolished. This work was completed without required permits. The Applicants stopped work onsite and submitted this application for a DRP in April 2021. The Applicants are requesting retroactive approval to demolish 982 square feet of the existing main floor of the residence, grading to provide a flat pad and the construction of a retaining wall on the north and east sides of the flat pad. In addition, the Applicants are requesting approval of the construction of 982 square feet in the same location as the demolition that has been completed as well as a 721 square foot addition to the residence on the existing flat pad, to legalize the existing detached ADU and perform site improvements including grading, retaining walls and on grade stairs. The project plans are provided in Attachment 2. If the Council is able to make the required findings and approve the project, a Condition of Approval has been added to the Resolution that would require the Applicants to pay double building permit fees for completing work without required permits.

Table 1 (below) provides a comparison of the SBMC applicable zoning regulations with the Applicants' proposed design.

Table 1			
LOT INFORMATION			
Property Address:	1246 Highland Dr.	Zoning Designation:	ER-2 (1-2 du/ac)
Lot Size (Gross):	28,749 ft ²	# of Units Allowed:	1 D/U, 1 ADU, and 1 JADU
Max. Allowable Floor Area:	8,812 ft ²	# of Units Requested:	1 D/U and 1 ADU
Proposed Floor Area:	4,099 ft ²	Setbacks:	Required Proposed
Below Max. Floor Area by:	4,713 ft ²	Front (E)	25 ft. 35 ft - 7 in
Max. Allowable Height:	25 ft.	Interior Side (N)	10 ft. 22 ft - 8 in*
Max. Proposed Height:	15 ft 4 in	Interior Side S	10 ft. 10 ft – 9.5 in**
Highest Point/Ridge:	307.57 MSL	Rear (W)	40 ft. 9 ft -10 in**
Existing Development:	existing residence, detached garage/storage building, detached ADU, detached storage shed	* Measured to the detached garage	
Proposed Parking:	2 spaces in garage	** Measured to the detached ADU	
Accessory Structures:	Yes	Proposed Grading:	180 yd ³ of cut 90 yd ³ of fill 90 yd ³ of export
Fences and Walls:	Yes		

2. The proposed development complies with the development review criteria.
3. All required permits and approvals issued by the city, including variances, conditional use permits, comprehensive sign plans, and coastal development permits have been obtained prior to or concurrently with the development review permit.
4. If the development project also requires a permit or approval to be issued by a state or federal agency, the city council may conditionally approve the development review permit upon the Applicants obtaining the required permit or approval from the other agency.

If the above findings cannot be made, the Council shall deny the DRP. The following is a discussion of the applicable development review criteria as they relate to the proposed project.

Relationship with Adjacent Land Uses:

The property is located within the ER-2 Zone. Surrounding properties are also located within the ER-2 Zone and are developed with a mixture of one- and two-story single-family residences. The project, as designed, is consistent with the permitted uses for the ER Zone as described in SBMC Sections 17.20.010 and 17.12.020. The property is designated Estate Residential in the General Plan and intended for estate types of residences developed at a maximum density of two dwelling units per acre. Other compatible uses include accessory dwelling units, home occupations, and religious and educational institutions. The proposed development could be found to be consistent with the objectives of the General Plan as it encourages the development and maintenance of healthy residential neighborhoods, the stability of transitional neighborhoods, and the rehabilitation of deteriorated neighborhoods. The project also could be found consistent with the objective of providing a range of housing types.

The property is not located within any of the City's Specific Plan areas; however, it is located within the boundaries of the Dark Sky Area. The project has been evaluated and the building permit plans would be conditioned to be in conformance with the regulations of the Dark Sky Area. The project is also located within the Coastal Zone. As a condition of project approval, the Applicants will be required to obtain a Coastal Development Permit, Waiver, or Exemption from the California Coastal Commission prior to the issuance of building or grading permits.

Building and Structure Placement:

The Applicants are proposing to construct a 1,703 square foot addition in place of the 928 square feet of the existing residence that has been demolished. The remainder of the existing residence would be remodeled. The Applicants are also requesting to legalize the existing unpermitted detached ADU located in the existing rear yard setback. An existing two-story garage/storage building, and a detached storage structure would remain onsite unchanged. The proposed addition would be located in the buildable area of the lot. There is an existing gated driveway off Highland Drive at the center of the southern (front) property line as well as a private road along the entire western property line that provides access to the detached garage/storage building on the property and the properties to the northwest.

The 3,083 square-foot residence would consist of the main entry, an open-concept living room, dining room, and kitchen with a pantry, laundry closet, a powder room, office and a primary bedroom suite on the main floor. The lower level would consist of two bedrooms, a bathroom, a utility room, and mechanical closet. A covered porch is proposed at the main entry and above grade decks are proposed off of the primary suite and the living room.

The SBMC parking regulations require two off-street parking spaces per single-family residence. When required spaces are provided in a garage, 200 square feet of floor area is exempted for each required space. The existing first floor of the detached 1,176 square-foot garage/storage building would provide two unobstructed parking spaces; therefore, 400 square feet of the garage is exempt from the calculation of floor area. With the exemption, the total proposed floor area onsite would be 4,099 square feet, which is the 4,713 square feet below the maximum allowable floor area for the 28,749 square-foot lot. The maximum allowable floor area calculation for this project is as follows:

0.60 for first 5,000 ft ²	3,000 ft ²
0.3 for 5,000 ft ² to 15,000 ft ²	4,500 ft ²
0.15 for lot area above 15,000 ft ²	1,312 ft ²
Maximum Allowable Floor Area:	8,812 ft²

As designed, the project complies with all required setbacks. The residence would be setback 35 feet 7 inches from the front property line, approximately 40 feet from the north side property line, approximately 65 feet from the rear property line, and approximately 75 feet from the southern side property line. The maximum building height for the ER Zone is 25 feet. The proposed addition to the residence would not exceed 16 feet above the pre-existing grade with the highest portion of the structure to be at 15 feet 4 inches or 307.57 feet above MSL. The existing two-story portion of the residence is 21 feet 10 inches above the existing grade or 307.03 MSL. As designed, the project will comply with the required parking, maximum floor area, required setbacks, and maximum building height.

Neighborhood Comparison:

Staff compared the proposed project to 24 other properties within the surrounding area. This area includes properties on the north of Highland Drive, on both east and west sides of Solana Drive and San Julio Drive and the west side of San Andreas Drive as shown on the following map.

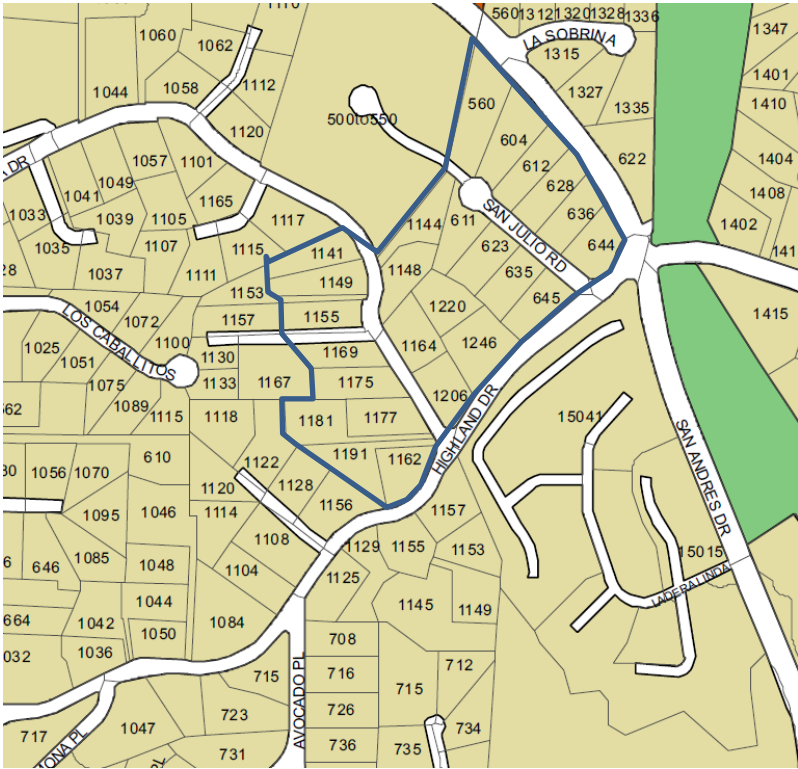

The properties evaluated in this comparison are also located in the ER Zone. The existing homes range in size from 1,558 square feet to 4,908 square feet, according to the County Assessor records. It should be noted that the County Assessor does not include the garage, covered porch area, unfinished basement, or non-habitable accessory building area in the total square footage. Accordingly, the building area of the proposed project has been calculated for comparison purposes by deleting the area of the proposed garage and the outdoor covered area:

Project Gross Building Area:	3,083 ft ²
Project Area for Comparison to Assessor's Data:	3,083 ft ²

Table 2 is based upon the County Assessor's data and SanGIS data. It contains neighboring lot sizes, the square footage of existing development and the maximum allowable square footage for potential development on each lot.

Table 2						
#	Property Address	Lot Size in ft ² (GIS)	Existing ft ² Onsite (Assessor's)	Proposed / Recently Approved ft ²	Max. Allowable ft ²	Zone
1	604 San Julio Drive	40,173	2,704		10,526	ER-2
2	612 San Julio Drive	30,279	2,204		9,042	ER-2
3	620 San Julio Drive	22,656	2,704		7,898	ER-2
4	628 San Julio Drive	22,656	2,204		7,898	ER-2
5	636 San Julio Drive	21,417	3,354		7,713	ER-2
6	644 San Julio Drive	22,332	3,214		7,850	ER-2
7	645 San Julio Drive	22,776	3,229		7,916	ER-2
8	635 San Julio Drive	20,728	3,306		7,609	ER-2
9	623 San Julio Drive	21,779	4,908		7,767	ER-2
10	611 San Julio Drive	20,681	3,448		7,602	ER-2
11	1144 Solana Drive	20,621	4,436		7,593	ER-2
12	1148 Solana Drive	21,615	1,558		7,742	ER-2
13	1220 Highland Drive	22,166	4,420		7,825	ER-2
14	1246 Highland Drive	28,749	2,918		8,812	ER-2
15	1206 Highland Drive	22,445	2,943		7,867	ER-2
16	1164 Solana Drive	22,905	1,592		7,936	ER-2
17	1141 Solana Drive	19,973	1,999		7,492	ER-2
18	1149 Solana Drive	22,164	2,928		7,825	ER-2
19	1155 Solana Drive	21,740	3,322		7,526	ER-2
20	1169 Solana Drive	25,463	1,620		8,319	ER-2
21	1175 Solana Drive	23,235	2,969		7,985	ER-2
22	1181 Solana Drive	27,944	4,081		8,692	ER-2
23	1191 Solana Drive	26,138	4,234		8,421	ER-2
24	1177 Solana Drive	23,733	3,005		8,060	ER-2
25	1162 Highland Drive	23,423	1,570	3,400	8,013	ER-2

Fences, Walls and Retaining Walls:

Within the front yard setback area, the SBMC Section 17.20.040(O) allows fences and walls, or any combination thereof, to be no higher than 42 inches in height as measured from existing grade, except for an additional two feet of fence that is at least 80% open to light. Fences, walls and retaining walls located within the rear and interior side yards are allowed to be up to six feet in height with an additional 24 inches that is 50% open to light and air.

The Applicants are proposing to maintain several existing retaining walls that step up the property and range in height from 1.2 feet to 5.7 feet above the existing grade. A retaining wall is proposed on the north and east sides of the proposed square footage addition that

would be 8.9 feet above the existing grade at its highest point. This wall is proposed in the buildable area of the lot where fences and walls can be up to 16 feet in height above the pre-existing grade. An existing fence that surrounds the entire property is proposed to remain. The Applicants are proposing to modify an existing retaining wall on the north side of the driveway in the southwest corner of the lot. A condition of approval has been added to require that the portion of the wall that is located within the required front yard setback would be required to comply with the maximum heights allowed by the SBMC.

If the Applicants decide to modify any of the proposed fences and walls or construct additional fences and walls on the project site, a condition of project approval indicates that they would be required to be in compliance with the Municipal Code.

Landscape:

The project is not subject to the current water efficient landscaping regulations of SBMC Chapter 17.56. A Landscape Documentation Package is required for new development projects with an aggregate landscape equal to or greater than 500 square feet requiring a building permit, plan check or development review. The Applicants are proposing to reduce 721 square feet of the existing landscaped in order to construct the new addition and the proposed retaining walls and on grade stairs. All other existing landscaping would remain.

Parking:

SBMC Section 17.52.040 and the Off-Street Parking Design Manual (OSPDM) require two (2) parking spaces for a single-family residence. There is an existing driveway along the western property line that leads to the detached 1,176 square foot, two-story garage and storage building. The garage has two unobstructed parking spaces that are 9 ft. X 19 ft. SBMC Section 17.08.030 indicates that required parking up to 200 square feet per parking space provided in a garage is exempt from the floor area calculation. Therefore, 400 square feet of garage area is exempt from the project's total floor area calculation.

One additional parking space would be required for the ADU because the property is not within 0.5 miles of a public transit stop. An additional parking space could be accommodated on the existing driveway in front of the existing primary residence.

Grading:

The project would include grading in the amount of 180 yd³ of cut, 90 yd³ of fill and 90 yd³ of export which would provide the flat pad for the addition to the main floor living area in the location where the existing residence was demolished. A retaining wall would support the higher grade adjacent to the square footage addition. Two on grade staircases are proposed on the northern side of the retaining wall in order to provide access to the existing detached ADU and the northern property line.

Lighting:

A condition of project approval requires that all new exterior lighting fixtures comply with the City-Wide Lighting Regulations of the Zoning Ordinance (SBMC 17.60.060). The project is located within the Dark Sky Area which has specific lighting regulations to preserve the traditional semirural character of the area which includes low levels of nighttime illumination. These regulations prohibit the outside illumination for aesthetic or dramatic purposes of any building and/or surrounding landscape, including environmentally sensitive habitat areas (public or private). Conditions of project approval include that all new exterior lighting fixtures comply with the City-Wide Lighting Regulations of the Zoning Ordinance (SBMC 17.60.060); that all light fixtures shall be shielded so that no light or glare is transmitted or reflected in such concentrated quantities or intensities as to be detrimental to the surrounding area; and that aesthetic illumination of the proposed residence or landscaping is prohibited.

Usable Open Space:

The project consists of the construction of an interior remodel and square footage addition to an existing single-family residence with a detached garage/storage building, detached ALU, and associated site improvements therefore, usable open space and recreational facilities are neither proposed nor required according to SBMC Section 17.20.040.

Proposed Street Improvements:

The existing property frontage is unimproved with landscaping. If approved, the Applicants will be required to remove the existing landscaping and construct an 8-ft wide D.G. pathway graded at 2% slope for walking and parking purposes. In addition, a mountable concrete curb for drainage will be required if the project is approved. The driveway approach will also be reconstructed as a condition of approval to meet ADA standards.

Public Hearing Notice:

Notice of the City Council Public Hearing for the project was published in the Union Tribune more than 10 days prior to the public hearing. The same public notice was mailed to property owners and occupants within 300 feet of the proposed project site on April 14, 2022. Staff has not received correspondence about the proposed development.

In conclusion, the proposed project, as conditioned, could be found to be consistent with the Zoning regulations and the General Plan. Staff has prepared draft findings for approval of the project in the attached Resolution 2022-031 for Council's consideration based upon the information in this report. Conditions from the Community Development, Engineering, and Fire Departments are incorporated in the Resolution of Approval.

The Council may direct Staff to modify the Resolution to reflect the findings and conditions it deems appropriate as a result of the Public Hearing process. If the Council determines

the project is to be denied, Staff will prepare a Resolution of Denial for adoption at a subsequent Council meeting.

CEQA COMPLIANCE STATEMENT:

The project is exempt from the California Environmental Quality Act (CEQA) pursuant to Section 15301 of the State CEQA Guidelines. Class 3 consists of construction and location of limited numbers of new, small facilities or structures. Examples of this exemption include (e) Additions to existing structures provided that the addition will not result in an increase of more than: (1) 50 percent of the floor area of the structures before the addition, or 2,500 square feet, whichever is less. 50% of the floor area of the existing structures 2,045 square feet including the ADU or 1,490 square feet not including the ADU. The addition of 721 square feet is less than 50% and can therefore, be found exempt.

FISCAL IMPACT: N/A

WORK PLAN: N/A

OPTIONS:

- Approve Staff recommendation adopting the attached Resolution 2022-031.
- Approve Staff recommendation subject to additional specific conditions necessary for the City Council to make all required findings for the approval of a DRP.
- Deny the project if all required findings for the DRP and cannot be made.

DEPARTMENT RECOMMENDATION:

The proposed project meets the minimum zoning requirements under the SBMC, may be found to be consistent with the General Plan and may be found, as conditioned, to meet the discretionary findings required as discussed in this report to approve a DRP. Therefore, Staff recommends that the City Council:

1. Conduct the Public Hearing: Open the Public Hearing, Report Council Disclosures, Receive Public Testimony, and Close the Public Hearing.
2. Find the project exempt from the California Environmental Quality Act pursuant to Section 15301 of the State CEQA Guidelines; and
3. If the City Council makes the requisite findings and approves the project, adopt Resolution 2022-031 conditionally approving a DRP to construct a 721 square-foot addition to an existing split-level, single-family residence with a detached 1,176 square-foot, two-story garage/storage building, and perform associated site improvements at 1246 Highland Drive, Solana Beach.

CITY MANAGER'S RECOMMENDATION:

Approve Department Recommendation.



Gregory Wade, City Manager

Attachments:

1. Resolution 2022-031
2. Project Plans

RESOLUTION 2022-031

A RESOLUTION OF THE CITY COUNCIL OF THE CITY OF SOLANA BEACH, CALIFORNIA, CONDITIONALLY APPROVING A DEVELOPMENT REVIEW PERMIT TO CONSTRUCT AN ADDITION TO AN EXISTING TWO-STORY, SINGLE-FAMILY RESIDENCE WITH A DETACHED GARAGE, TO LEGALIZE AN EXISTING DETACHED ACCESSORY DWELLING UNIT (ADU), AND PERFORM ASSOCIATED IMPROVEMENTS AT 1246 HIGHLAND DRIVE, SOLANA BEACH.

**APPLICANTS: BRENT AND LESLIE STRINGER
APPLICATION: DRP21-005**

WHEREAS, Brent and Leslie Stringer (hereinafter referred to as “Applicants”), have submitted an application for a Development Review Permit (DRP) pursuant to Title 17 (Zoning) of the Solana Beach Municipal Code (SBMC); and

WHEREAS, the Public Hearing was conducted pursuant to the provisions of Solana Beach Municipal Code Section 17.72.030; and

WHEREAS, at the Public Hearing on April 27, 2022, the City Council received and considered evidence concerning the proposed application; and

WHEREAS, the City Council of the City of Solana Beach found the application request exempt from the California Environmental Quality Act pursuant to Section 15301 of the State CEQA Guidelines; and

WHEREAS, this decision is based upon the evidence presented at the Public Hearing, and any information the City Council gathered by viewing the site and the area as disclosed at the Public Hearing.

NOW THEREFORE, the City Council of the City of Solana Beach, California, does resolve as follows:

- I. That the foregoing recitations are true and correct.
- II. That the request for a DRP to construct an addition to an existing two-story, single-family residence with a detached attached garage, to legalize an existing detached ADU and perform associated site improvements at 1246 Highland Drive, is conditionally approved based upon the following Findings and subject to the following Conditions:

III. FINDINGS

- A. In accordance with Section 17.68.040 (Development Review Permit) of the City of Solana Beach Municipal Code, the City Council finds the following:

- I. *The proposed project is consistent with the General Plan and all applicable requirements of SBMC Title 17 (Zoning Ordinance), including special regulations, overlay zones and specific plans.*

General Plan Consistency: The project, as conditioned, is consistent with the City's General Plan designation of Estate Residential, which allows for a maximum of one to two dwelling units per acre. The development is also consistent with the objectives of the General Plan as it encourages the development and maintenance of healthy residential neighborhoods, the stability of transitional neighborhoods, and the rehabilitation of deteriorated neighborhoods.

Zoning Ordinance Consistency: The project is consistent with all applicable requirements of the Zoning Ordinance (Title 17) (SBMC 17.20.030 and 17.48.040), which delineates maximum allowable Floor Area Ratio (FAR), Permitted Uses and Structures (SBMC Section 17.20.020), which provides for uses of the property for a single-family residence. Further, the project adheres to all property development regulations established for the ER Zone and cited by SBMC Section 17.020.030.

The project is consistent with the provisions for minimum yard dimensions (i.e., setbacks), maximum allowable floor area, maximum allowable building height, and parking requirements.

- II. *The proposed development complies with the following development review criteria set forth in Solana Beach Municipal Code Section 17.68.040.F:*

- a. *Relationship with Adjacent Land Uses: The development shall be designed in a manner compatible with and where feasible, complimentary to existing and potential development in the immediate vicinity of the project site. Site planning on the perimeter of the development shall give consideration to the protection of surrounding areas from potential adverse effects, as well as protection of the property from adverse surrounding influences.*

The property is located within the ER-2 Zone. Surrounding properties are also located within the ER-2 Zone and are developed with a mixture of one- and two-story single-family residences. The project, as designed, is consistent with the permitted uses for the ER Zone as described in SBMC Sections 17.20.010 and 17.12.020. The property is designated Estate Residential in the General Plan and intended for estate types of residences developed at a maximum density of two dwelling units per acre. Other compatible uses include accessory

dwelling units, home occupations, religious and educational institutions. The proposed development could be found to be consistent with the objectives of the General Plan as it encourages the development and maintenance of healthy residential neighborhoods, the stability of transitional neighborhoods, and the rehabilitation of deteriorated neighborhoods. The project also could be found consistent with the objective of providing a range of housing types.

The property is not located within any of the City's Specific Plan areas; however, it is located within the boundaries of the Dark Sky Area. The project has been evaluated and the building permit plans would be conditioned to be in conformance with the regulations of the Dark Sky Area. The project is also located within the Coastal Zone. As a condition of project approval, the Applicants will be required to obtain a Coastal Development Permit, Waiver, or Exemption from the California Coastal Commission prior to the issuance of building or grading permits.

- b. *Building and Structure Placement: Buildings and structures shall be sited and designed in a manner which visually and functionally enhances their intended use.*

The Applicants are proposing construct a 1,703 square foot addition in place of the 928 square feet of the existing residence that has been demolished. The remainder of the existing residence would be remodeled. The Applicants are also requesting to legalize the existing unpermitted ADU located in the existing rear yard setback. An existing two-story garage/storage building and a detached storage structure would remain onsite unchanged. The proposed addition would be located in the buildable area of the lot. There is an existing gated driveway off of Highland Drive at the center of the northeastern property line as well as a private road along the entire southwestern property line that provides access to the detached garage/storage building on the property and the properties to the west.

The 3,083 square-foot residence would consist of the main entry, an open-concept living room, dining room, and kitchen with a pantry, laundry closet, a powder room, office and a primary bedroom suite on the main floor. The lower level would consist of two bedrooms, a bathroom, a utility room, and mechanical closet. A covered porch is proposed at the main entry and above grade decks are proposed off of the primary sweet and the living room.

The SBMC parking regulations require two off-street parking spaces per single-family residence. When required spaces are provided in a garage, 200 square feet of floor area is exempted for each required space. The existing first floor of the detached 1,176 square-foot garage/storage building would provide two unobstructed parking spaces; therefore, 400 square feet of the garage is exempt from the calculation of floor area. With the exemption, the total proposed floor area would be 4,099 square feet, which is 4,713 square feet below the maximum allowable floor area for the 28,749 square-foot lot. The maximum allowable floor area calculation for this project is as follows:

0.60 for the first 5,000 ft ²	3,000 ft ²
0.30 for 5,000 to 15,000 ft ²	4,500 ft ²
0.15 for lot area above 15,000 ft ²	1,312 ft ²
<u>Maximum Allowable Floor Area</u>	<u>8,812 ft²</u>

As designed, the project complies with all required setbacks. The residence would be setback 35 feet 7 inches from the front property line, approximately 40 feet from the north side property line, approximately 65 feet from the rear property line, and approximately 75 feet from the southern side property line. The maximum building height for the ER Zone is 25 feet. The proposed addition to the residence would not exceed 16 feet above the pre-existing grade with the highest portion of the structure to be at 15 feet 4 inches or 307.57 feet above MSL. The existing two-story portion of the residence is 21 feet 10 inches above the existing grade or 307.03 MSL. As designed, the project will comply with the required parking, maximum floor area, required setbacks, and maximum building height.

- c. *Landscaping: The removal of significant native vegetation shall be minimized. Replacement vegetation and landscaping shall be compatible with the vegetation of the surrounding area. Trees and other large plantings shall not obstruct significant views when installed or at maturity.*

The project is not subject to the current water efficient landscaping regulations of SBMC Chapter 17.56. A Landscape Documentation Package is required for new development projects with an aggregate landscape equal to or greater than 500 square feet requiring a building permit, plan check or development review. The Applicants are proposing to reduce 721 square feet of the existing landscaped in order to construct

the new addition and the proposed retaining walls and on grade stairs. All other existing landscaping would remain.

- d. *Roads, Pedestrian Walkways, Parking and Storage Areas: Any development involving more than one building or structure shall provide common access roads and pedestrian walkways. Parking and outside storage areas, where permitted, shall be screened from view, to the extent feasible, by existing topography, by the placement of buildings and structures, or by landscaping and plantings.*

SBMC Section 17.52.040 and the Off-Street Parking Design Manual (OSPDM) require two (2) parking spaces for a single-family residence. There is an existing driveway along the western property line that leads to the detached 1,176 square foot, two-story garage and storage building. The garage has two unobstructed parking spaces that are 9 ft. X 19 ft. SBMC Section 17.08.030 indicates that required parking up to 200 square feet per parking space provided in a garage is exempt from the floor area calculation. Therefore, 400 square feet of garage area is exempt from the project's total floor area calculation.

One additional parking space would be required for the ADU because the property is not within 0.5 miles of a public transit stop. An additional parking space could be accommodated on the existing driveway in front of the existing primary residence.

The existing property frontage is unimproved with landscaping. If approved, the Applicants will be required to remove the existing landscaping and construct an 8-ft wide D.G. pathway graded at 2% slope for walking and parking purposes. In addition, a mountable concrete curb for drainage will be required if the project is approved. The driveway approach will also be reconstructed as a condition of approval to meet ADA standards.

- e. *Grading: To the extent feasible, natural topography and scenic features of the site shall be retained and incorporated into the proposed development. Any grading or earth-moving operations in connection with the proposed development shall be planned and executed so as to blend with the existing terrain both on and adjacent to the site. Existing exposed or disturbed slopes shall be landscaped with native or naturalized non-native vegetation and existing erosion problems shall be corrected.*

The project would include grading in the amount of 180 yd³ of cut, 90 yd³ of fill and 90 yd³ of export which would provide the

flat pad for the addition to the main floor living area in the location where the existing residence was demolished. A retaining wall would support the higher grade adjacent to the square footage addition. Two on grade staircases are proposed on the northern side of the retaining wall in order to provide access to the existing detached ADU and the northern property line.

- f. Lighting: Light fixtures for walkways, parking areas, driveways, and other facilities shall be provided in sufficient number and at proper locations to assure safe and convenient nighttime use. All light fixtures shall be appropriately shielded so that no light or glare is transmitted or reflected in such concentrated quantities or intensities as to be detrimental to the surrounding areas per SBMC 17.60.060 (Exterior Lighting Regulations).*

A condition of project approval requires that all new exterior lighting fixtures comply with the City-Wide Lighting Regulations of the Zoning Ordinance (SBMC 17.60.060). The project is located within the Dark Sky Area and is subject which has specific lighting regulations to preserve the traditional semirural character of the area which includes low levels of nighttime illumination. These regulations prohibit the outside illumination for aesthetic or dramatic purposes of any building and/or surrounding landscape, including environmentally sensitive habitat areas (public or private). Conditions of project approval include that all new exterior lighting fixtures comply with the City-Wide Lighting Regulations of the Zoning Ordinance (SBMC 17.60.060); that all light fixtures shall be shielded so that no light or glare is transmitted or reflected in such concentrated quantities or intensities as to be detrimental to the surrounding area; and that aesthetic illumination of the proposed residence or landscaping is prohibited.

- g. Usable Open Space: Recreational facilities proposed within required usable open space shall be located and designed to maintain essential open space values.*

The project consists of the construction of an interior remodel and square footage addition to an existing single-family residence with a detached garage/storage building, detached ALU, and associated site improvements therefore, usable open space and recreational facilities are neither proposed nor required according to SBMC Section 17.20.040.

- III. All required permits and approvals including variances, conditional use permits, and comprehensive sign plans have been obtained prior to or concurrently with the development review permit.*

All required permits are being processed concurrently with the Development Review Permit.

- IV. If the development project also requires a permit or approval to be issued by a state or federal agency, the city council may conditionally approve the development review permit upon the Applicants obtaining the required permit or approval from the other agency.*

The Applicants are required to obtain approval from the California Coastal Commission prior to issuance of Building and Grading Permits.

IV. CONDITIONS

Prior to use or development of the property in reliance on this permit, the Applicants shall provide for and adhere to the following conditions:

A. Community Development Department Conditions:

- I. The Applicants shall pay required Fire Mitigation, Park Development, Public Use Facilities, and Public Facilities Impact Fees.
- II. Building Permit plans must be in substantial conformance with the architectural plans presented to the City Council on April 27, 2022, and located in the project file with a submittal date of February 11, 2022.
- III. The Applicants shall pay double building permit fees for completing work without required permits.
- IV. Prior to requesting a framing inspection, the Applicants shall submit a height certification, signed by a licensed land surveyor, certifying that the building envelope of the proposed addition is in conformance with the plans as approved by the City Council on April 27, 2022 and will not exceed 15 feet 4 inches in height from the pre-existing grade or 307.57 feet above MSL.
- V. Any proposed onsite fences, walls and retaining walls and any proposed railing located on top, or any combination thereof, shall comply with applicable regulations of SBMC Section 17.20.040 and 17.60.070 (Fences and Walls).
- VI. The Applicants shall obtain required California Coastal Commission (CCC) approval of a Coastal Development Permit, Waiver or

Exemption as determined necessary by the CCC, prior to the issuance of Building and Grading Permits.

- VII. Native or drought tolerant and non-invasive plant materials and water conserving irrigation systems shall be incorporated into any proposed landscaping and compatible with the surrounding area to the extent feasible.
 - VIII. All new exterior lighting fixtures shall be in conformance with the City-wide lighting regulations of the Zoning Ordinance (SBMC 17.60.060). All light fixtures shall be appropriately shielded so that no light or glare is transmitted or reflected in such concentrated quantities or intensities as to be detrimental to the surrounding area.
 - IX. The aesthetic-illumination of the proposed residence or landscaping is prohibited.
 - X. Construction vehicles shall be parked on the subject property at all times feasible. If construction activity prohibits parking on the subject property, the Applicants shall ensure construction vehicles are parked in such a way to allow sufficient vehicular access on the street and minimize impact to the surrounding neighbors.
 - XI. The Applicants shall connect to temporary electrical service as soon as feasible to the satisfaction of the City. The use of gas-powered generator(s) during construction activity is discouraged and shall be limited only to selective use at the discretion of the City.
- B. Fire Department Conditions:
- I. **ACCESS ROAD MINIMUM DIMENSIONS:** Fire apparatus access roads shall have an unobstructed improved width of not less than 20 feet; curb line to curb line, and an unobstructed vertical clearance of not less than 13 feet 6 inches. Exception: Single-Family residential driveways; serving no more than two single-family dwellings, shall have minimum of 16 feet, curb line to curb line, of unobstructed improved width. Access roads shall be designed and maintained to support the imposed loads of not less than 75,000 pounds and shall be provided with an approved paved surface to provide all-weather driving capabilities.
 - II. **GATES:** All gates or other structures or devices, which could obstruct fire access roadways or otherwise hinder emergency operations, are prohibited unless they meet standards approved by the Fire Department. An approved emergency key-operated switch and/or an

approved emergency traffic control-activating strobe light sensor shall be installed per Solana Beach Fire Department standards.

- III. OBSTRUCTION OF ROADWAYS DURING CONSTRUCTION: All roadways shall be a minimum of 20 feet in width during construction and maintained free and clear, including the parking of vehicles, in accordance with the California Fire Code and the Solana Beach Fire Department.
- IV. ADDRESS NUMBERS: STREET NUMBERS: Approved numbers and/or addresses shall be placed on all new and existing buildings and at appropriate additional locations as to be plainly visible and legible from the street or roadway fronting the property from either direction of approach. Said numbers shall contrast with their background, and shall meet the following minimum standards as to size: 4" high with a ½" inch stroke width for residential buildings, 8" high with a ½" stroke for commercial and multi-family residential buildings, 12" high with a 1" stroke for industrial buildings. Additional numbers shall be required where deemed necessary by the Fire Marshal, such as rear access doors, building corners, and entrances to commercial centers.
- V. AUTOMATIC FIRE SPRINKLER SYSTEM-ONE AND TWO FAMILY DWELLINGS: Structures shall be protected by an automatic fire sprinkler system designed and installed to the satisfaction of the Fire Department. Plans for the automatic fire sprinkler system shall be approved by the Fire Department prior to installation. Sprinklers shall be installed in both the main residence and the ADU.
- VI. CLASS "A" ROOF: All structures shall be provided with a Class "A" Roof covering to the satisfaction of the Solana Beach Fire Department.

C. Engineering Department Conditions:

- I. The Applicants are required to obtain an Encroachment Permit in accordance with SBMC Section 11.20 for the below frontage improvements being done in the public right-of-way. The frontage improvements shall be done to the satisfaction of the City Engineer prior to the occupancy of the proposed project:
 - a. Construction of the 8-ft wide D.G area compacted and graded at maximum 2% towards the flow line for walking and parking purposes to the satisfaction of the City Engineer.
 - b. Construction of the 9" X 9" X 12" concrete curb along the property frontage with transitions to the existing improvements on both ends to the satisfaction of the City Engineer.

- c. Removal of the existing cycads and landscaping.
 - d. Construction of the SDRSD modified G-14 driveway approach with 2:1 transitions to the proposed D.G. pathway.
 - e. Removal of the existing freestanding entry wall.
- II. All construction demolition materials shall be recycled according to the City's Construction and Demolition recycling program and an approved Waste Management Plan shall be submitted.
- III. Construction fencing shall be located on the subject property unless the Applicants have obtained an Encroachment Permit in accordance with chapter 11.20 of the SBMC which allows otherwise.
- IV. The Applicants shall obtain a Grading Permit in accordance with Chapter 15.40 of the Solana Beach Municipal Code. Conditions prior to the issuance of a grading permit shall include, but not be limited to, the following:
- a. The Applicants shall obtain a grading plan prepared by a Registered Civil Engineer and approved by the City Engineer. On-site grading design and construction shall be in accordance with Chapter 15.40 of the Solana Beach Municipal Code.
 - b. The Applicants shall obtain a Soils Report prepared by a Registered Soils Engineer and approved by the City Engineer. All necessary measures shall be taken and implemented to assure slope stability, erosion control and soil integrity. The grading plan shall incorporate all recommendations contained in the soils report.
 - c. The Applicants shall provide a Drainage Report prepared by a Registered Civil Engineer. This report shall address the design for detention basin and corresponding outflow system to ensure the rate of runoff for the proposed development is at or below that of pre-existing condition. All recommendations of this report shall be incorporated into the Preliminary Grading Plan. A detention basin easement(s) shall be recorded for maintenance of the detention basins by the property owner(s) in perpetuity, prior to the release of the Grading Bond and Security Deposit.
 - d. The Applicants shall show all retaining walls and drainage structures. Retaining walls shown on the grading plan shall conform to the San Diego Regional Standards or be designed by

a licensed civil engineer. Engineering calculations for all designed walls with a surcharge and nonstandard walls shall be submitted at grading plan check. Retaining walls may not exceed the allowable height within the property line setback as determined by the City of Solana Beach Municipal Code. Contact the Community Development department for further information.

- e. The Applicants are responsible to protect the adjacent properties during construction. If any grading, construction activity, access or potential construction-related impacts are anticipated beyond the property lines, as determined by the City Engineer, the Applicants shall obtain a letter of permission from the adjoining property owners. All required letters of permission shall be submitted to the City Engineer prior to the issuance of the grading permit.
- f. Cut and fill slopes shall be set back from site boundaries and buildings in accordance with SBMC 15.40.140 and to the satisfaction of the City Engineer.
- g. The Applicants shall pay a grading plan check fee in accordance with the current Engineering Fee Schedule at initial grading plan submittal. Inspection fees shall be paid prior to issuance of the grading permit.
- h. The Applicants shall obtain and submit grading security in a form prescribed by the City Engineer.
- i. The Applicants shall obtain haul permit for import / export of soil. The Applicants shall transport all excavated material to a legal disposal site.
- j. The Applicants shall submit certification from the Engineer of Record and the Soils Engineer that all public or private drainage facilities and finished grades are functioning and are installed in accordance with the approved plans. This shall be accomplished by the Engineer of Record incorporating as-built conditions on the Mylar grading plans and obtaining signatures of the Engineer of Record and the Soils Engineer certifying the as-built conditions.
- k. An Erosion Prevention and Sediment Control Plan shall be prepared by the Applicants. Best management practices shall be developed and implemented to manage storm water and non-storm water discharges from the site at all times during excavation and grading activities. Erosion prevention shall be emphasized as the most important measure for keeping

sediment on site during excavation and grading activities. Sediment controls shall be used as a supplement to erosion prevention for keeping sediment on site.

- I. The Applicants shall show all proposed on-site private drainage facilities intended to discharge water run-off. Elements of this design shall include a hydrologic and hydraulic analysis verifying the adequacy of the facilities and identify any easements or structures required to properly convey the drainage. The construction of drainage structures shall comply with the standards set forth by the San Diego Regional Standard Drawings.
- m. Post Construction Best Management Practices meeting City and RWQCB Order No. R9-2013-001 requirements shall be implemented in the drainage design.
- n. No increased cross lot drainage shall be allowed.
- o. Prior to obtaining a building permit, the Applicants shall submit a building pad certification statement from a soils engineer and an engineer or land surveyor licensed in Land Surveying per SBMC 15.40.230E. If a demo permit is required for removing existing structures before grading, the Applicants shall obtain the demo permit separately in order to certify the grading prior to issuance of the Building Permit.

D. City Council Conditions:

- I. N/A

V. EXPIRATION

The Development Review Permit for the project will expire 24 months from the date of this Resolution, unless the Applicants have obtained building permits and has commenced construction prior to that date, and diligently pursued construction to completion. An extension of the application may be granted by the City Council according to SBMC 17.72.110.

VI. INDEMNIFICATION AGREEMENT

The Applicants shall defend, indemnify, and hold harmless the City, its agents, officers, and employees from any and all claims, actions, proceedings, damages, judgments, or costs, including attorney's fees, against the City or its agents, officers, or employees, relating to the issuance of this permit including, but not limited to, any action to attack, set aside, void, challenge, or annul this

development approval and any environmental document or decision. The City will promptly notify the Applicants of any claim, action, or proceeding. The City may elect to conduct its own defense, participate in its own defense, or obtain independent legal counsel in defense of any claim related to this indemnification. In the event of such election, the Applicants shall pay all of the costs related thereto, including without limitation reasonable attorney's fees and costs. In the event of a disagreement between the City and Applicants regarding litigation issues, the City shall have the authority to control the litigation and make litigation related decisions, including, but not limited to, settlement or other disposition of the matter. However, the Applicants shall not be required to pay or perform any settlement unless such settlement is approved by the Applicants.

NOTICE TO APPLICANTS: Pursuant to Government Code Section 66020, you are hereby notified that the 90-day period to protest the imposition of the fees, dedications, reservations or other exactions described in this resolution commences on the effective date of this resolution. To protest the imposition of any fee, dedications, reservations or other exactions described in this resolution you must comply with the provisions of Government Code Section 66020. Generally the resolution is effective upon expiration of the tenth day following the date of adoption of this resolution, unless the resolution is appealed or called for review as provided in the Solana Beach Zoning Ordinance.

PASSED AND ADOPTED at a regular meeting of the City Council of the City of Solana Beach, California, held on the 27th day of April 2022, by the following vote:

AYES: Councilmembers –
NOES: Councilmembers –
ABSENT: Councilmembers –
ABSTAIN: Councilmembers –

LESA HEEBNER, MAYOR

APPROVED AS TO FORM:

ATTEST:

JOHANNA N. CANLAS, City Attorney

ANGELA IVEY, City Clerk



EXISTING SITE PLAN
SCALE: 1/10" = 1'-0"

ATTACHMENT 2

SITE PLAN KEYNOTES

- 1 PLANTED AREA
- 2 EXISTING EDGE OF PAVEMENT
- 3 EXISTING FENCE
- 4 EXISTING SINGLE FAMILY RESIDENCE
- 5 EXISTING DETACHED GARAGE WITH SECOND FLOOR - SEE ORIGINAL PLANS 4 OF 5 AND 5 OF 5
- 6 EXISTING DETACHED LIVING UNIT - NON-PERMITTED
- 7 EXISTING ABOVE GRADE DECK
- 8 EXIST. CONC. PATIO & STAIRS
- 9 EXISTING CONC. DRIVEWAY
- 10 EXISTING SWIMMING POOL AND CONCRETE DECK
- 11 EXISTING MOTORIZED GATE
- 12 PROPERTY LINE
- 13 SETBACK LINE
- 14 EXISTING RETAINING WALL TO BE REMOVED
- 15 PROPOSED OUTLINE OF BUILDING ADDITION
- 16 EXISTING RETAINING WALL
- 17 EXISTING CONCRETE DRIVEWAY
- 18 EXISTING CONCRETE WALKWAY
- 19 EXISTING 240 S.F. SINGLE STORY TEMPORARY STORAGE SHED

PROJECT SCOPE

- THE PROJECT SCOPE INCLUDES THE FOLLOWING:
- DEMOLISH AN EXISTING SITE RETAINING WALL
 - CONSTRUCT A NEW SITE RETAINING WALL
 - DEMOLISH A SINGLE STORY PORTION OF AN EXISTING TWO STORY SINGLE FAMILY RESIDENCE
 - CONSTRUCT A NEW SINGLE STORY ADDITION TO AN EXISTING TWO STORY SINGLE FAMILY RESIDENCE
 - PERMIT AN EXISTING DETACHED LIVING UNIT AS AN ADU

VICINITY MAP

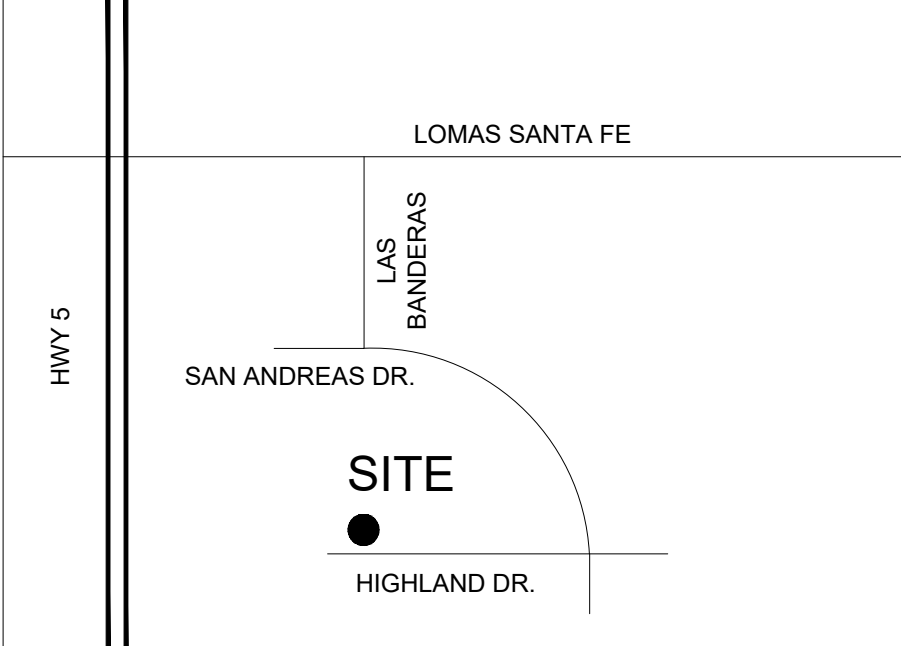

SHEET LIST

ARCHITECTURAL	
A-1.0	EXISTING SITE PLAN
A-1.1	PROPOSED SITE PLAN
A-2.0	DEMO PLANS
A-2.1	FLOOR PLANS
A-3.0	EXTERIOR ELEVATIONS RESIDENCE
A-4.0	SECTIONS & EXTERIOR ELEVATIONS ADU
CIVIL	
1 OF 2	PRELIMINARY GRADING PLAN
2 OF 2	TOPOGRAPHIC SURVEY
ORIGINAL GARAGE DRAINGS	
4 OF 5	PLANS
5 OF 5	ELEVATIONS



jeff parshalle architect
p o box 230132
encinitas ca 92023
619 . 985 . 4099
jeff @ jparch.net

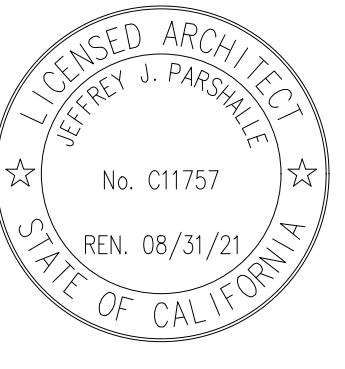

These drawings and specifications are the property and copyright of the architect and shall not be used on any other work except by agreement with the architect. Written dimensions shall take precedence over scaled dimensions and shall be verified on the job site. Any discrepancy shall be brought to the notice of the architect prior to the commencement of any work.

STRINGER RESIDENCE
1246 HIGHLAND DRIVE
SOLANA BEACH, CA 92014

NO.	DATE	ISSUE
11	02/10/22	DRP RESUBMITTAL
12	03/10/22	DRP RESUBMITTAL

PROJECT NUMBER
19284

A-1.0

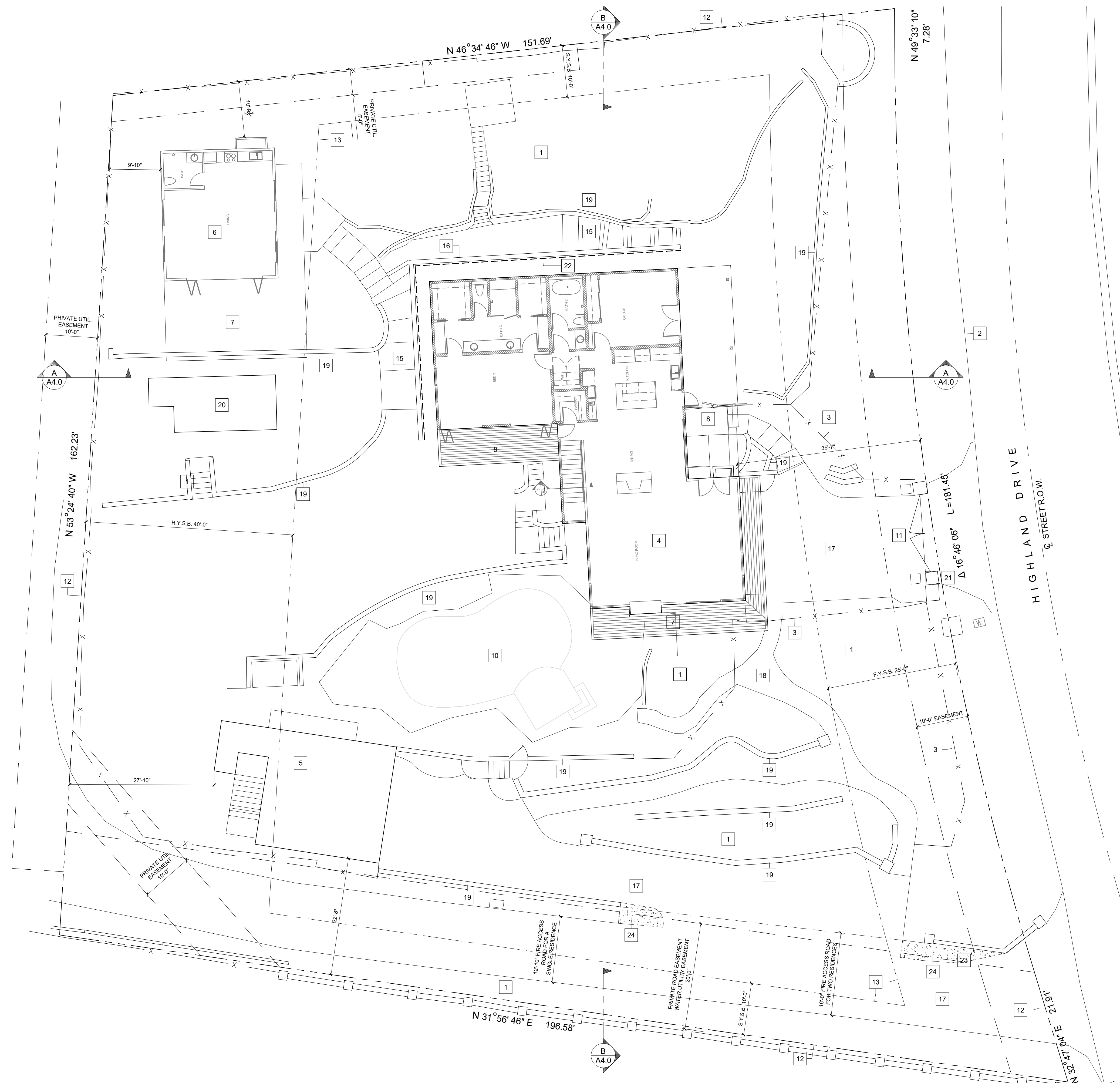

PROPOSED SITE PLAN
SCALE: 1/10" = 1'-0"

SITE PLAN KEYNOTES

- 1 PLANTED AREA
- 2 EXISTING EDGE OF PAVEMENT
- 3 EXISTING FENCE
- 4 EXISTING SINGLE FAMILY RESIDENCE
- 5 EXISTING DETACHED GARAGE WITH SECOND FLOOR - SEE ORIGINAL PLAN SHEETS 4 OF 5 AND 5 OF 5
- 6 EXISTING DETACHED LIVING UNIT - TO BE PERMITTED AS ADU
- 7 EXISTING ABOVE GRADE DECK
- 8 EXIST. CONC. PATIO & STAIRS
- 9 EXISTING CONC. DRIVEWAY
- 10 EXISTING SWIMMING POOL AND CONCRETE DECK
- 11 EXISTING MOTORIZED GATE - PROVIDE AN EMERGENCY KEY OPERATED SWITCH PER CITY STANDARDS
- 12 PROPERTY LINE
- 13 SETBACK LINE
- 14 PROPOSED LANDSCAPE STACKED BLOCK WALL
- 15 PROPOSED ONGRADE STAIRS & WALKWAY
- 16 PROPOSED NEW RETAINING WALL
- 17 EXISTING CONCRETE DRIVEWAY
- 18 EXISTING CONCRETE WALKWAY
- 19 EXISTING RETAINING WALL
- 20 EXIST. 240 S.F. SINGLE STORY TEMPORARY STORAGE SHED
- 21 PROVIDE ADDRESS NUMBERS CONTRASTING WITH THEIR BACKGROUND AND MINIMUM 4" HIGH WITH 0.5" STROKE
- 22 CUT LINE SHOWN DASHED
- 23 MODIFY ENTRY WALL TO ALLOW FOR A 16' WIDE PAVED ROAD
- 24 ADD PAVING

CONTACT INFORMATION

OWNERS: BRENT AND LESLIE STRINGER
1246 HIGHLAND DRIVE
SOLANA BEACH, CA 92014

SITE DATA

AGE OF EXIST. STRUCTURES: 1970
 ZONE: ER-2b
 SETBACKS:
 REAR: 40'-0"
 SIDE: 10'-0"
 FRONT: 25'-0"
 HEIGHT LIMIT: 25'-0"
 EXISTING BUILDING HGT.: 21'-10"
 PROPOSED BUILDING HGT.: 21'-10"
 PROPOSED ADDITION HGT.: 15'-4"
 LOT AREA: 28,749 SQ. FT.
 A.P.N.: 298-370-38-00
 GROSS FLOOR AREA:
 EXISTING FIRST FLOOR RESIDENCE 660 SQ. FT.
 EXISTING SECOND FLOOR RESIDENCE 1,702 SQ. FT.
 EXISTING SECOND FLOOR RESIDENCE DEMO (982) SQ. FT.
 SECOND FLOOR ADDITION RESIDENCE 1,703 SQ. FT.
 FIRST FLOOR EXISTING DETACHED GARAGE 588 SQ. FT.
 SECOND FLOOR EXISTING DETACHED GARAGE 588 SQ. FT.
 TOTAL SQUARE FOOTAGE: 4,259 SQ. FT.
 DETACHED GARAGE: (400) SQ. FT.
 APPLIED SQUARE FOOTAGE: 3,859 SQ. FT.
 ALLOWABLE FLOOR AREA :
 0.6 X 5,000 = 3,000 S.F.
 0.3 X 15,000 = 4,500 S.F.
 0.15 X 8,749 = 1,312 S.F.
 TOTAL 8,812 S.F.
 DETACHED LIVING UNIT - PROPOSED ADU 552 SQ. FT.

LAND USE

	EXISTING	PROPOSED
NON-LANDSCAPE	12,318 S.F.	13,039 S.F.
NON IRRIGATED LANDSCAPE	0 S.F.	0 S.F.
IRRIGATED LANDSCAPE	15,794 S.F.	15,073 S.F.
WATER FEATURES	637 S.F.	637 S.F.
DECORATIVE HARDSCAPE	0 S.F.	0 S.F.
TOTAL LOT AREA	28,749 SQ. FT.	28,749 SQ. FT.

	AREA OF WORK
IRRIGATED LANDSCAPE	0 S.F.
WATER FEATURES	0 S.F.
DECORATIVE HARDSCAPE	200 S.F.
AGGREGATE LANDSCAPE AREA	200 S.F.



jeff parshalle architect
p o box 230132
encinitas ca 92023
619 . 985 . 4099
jeff @ jparch.net

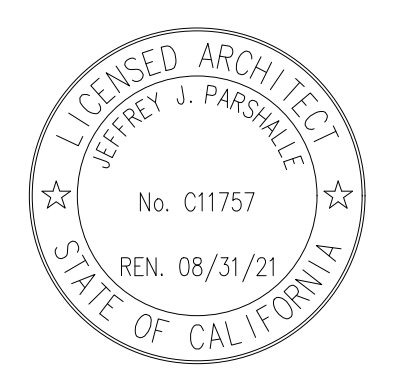

These drawings and specifications are the property and copyright of the architect and shall not be used on any other work except by agreement with the architect. Written dimensions shall take preference over scaled dimensions and shall be verified on the job site. Any discrepancy shall be brought to the notice of the architect prior to the commencement of any work.

STRINGER RESIDENCE
1246 HIGHLAND DRIVE
SOLANA BEACH, CA 92014

NO.	DATE	ISSUE
11	02/10/22	DRP RESUBMITTAL
12	03/10/22	DRP RESUBMITTAL

PROJECT NUMBER
19284



jeff parshalle architect
 p o box 230132
 encinitas ca 92023
 619 . 985 . 4099
 jeff @ jparch.net

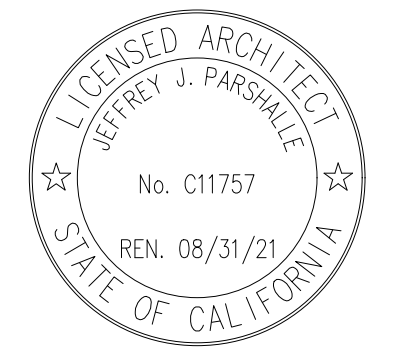

These drawings and specifications are the property and copyright of the architect and shall not be used on any other work except by agreement with the architect. Written dimensions shall take preference over scaled dimensions and shall be verified on the job site. Any discrepancy shall be brought to the notice of the architect prior to the commencement of any work.

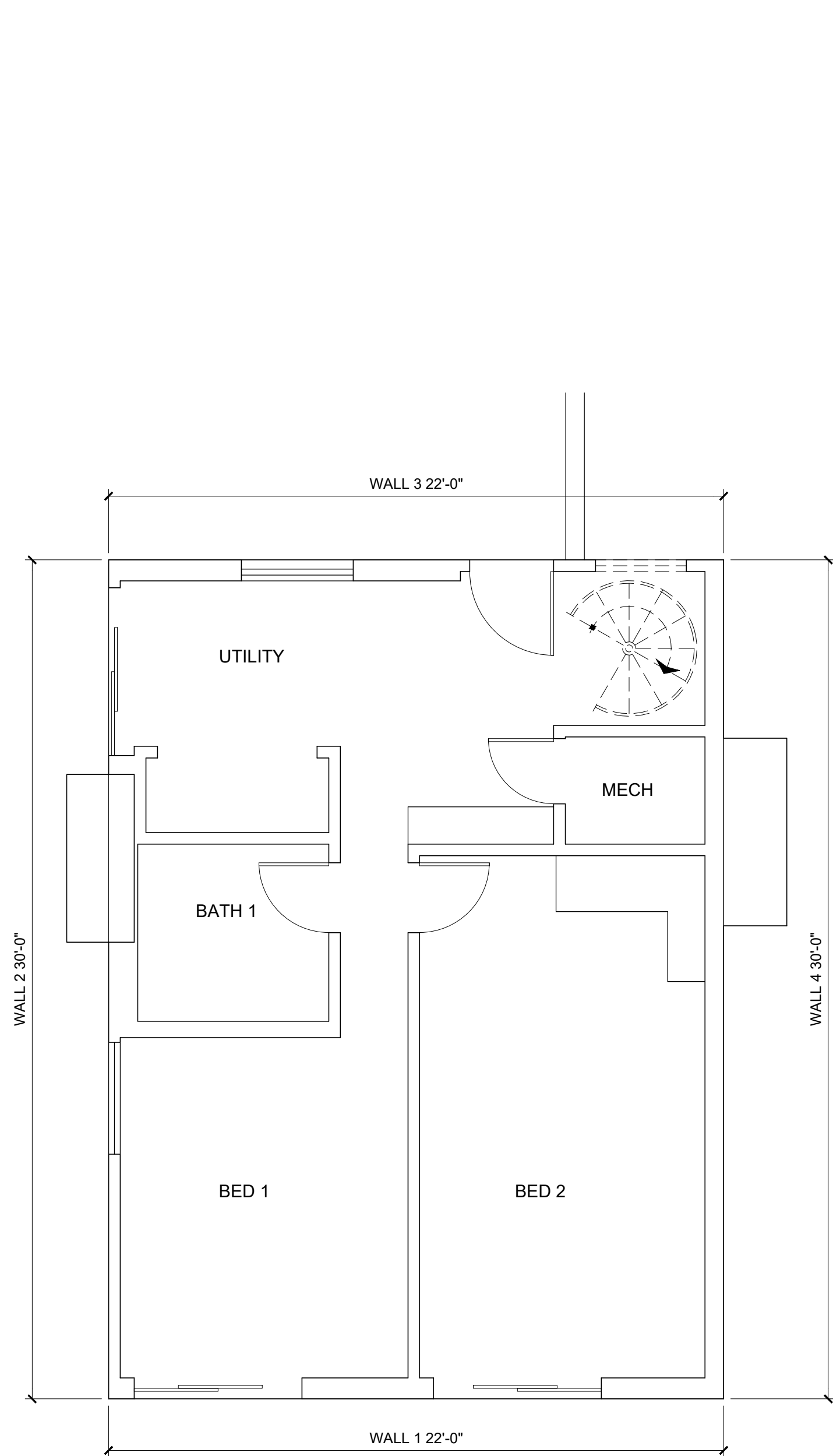

LOWER FLOOR DEMO PLAN

SCALE: 1/4" = 1'-0"

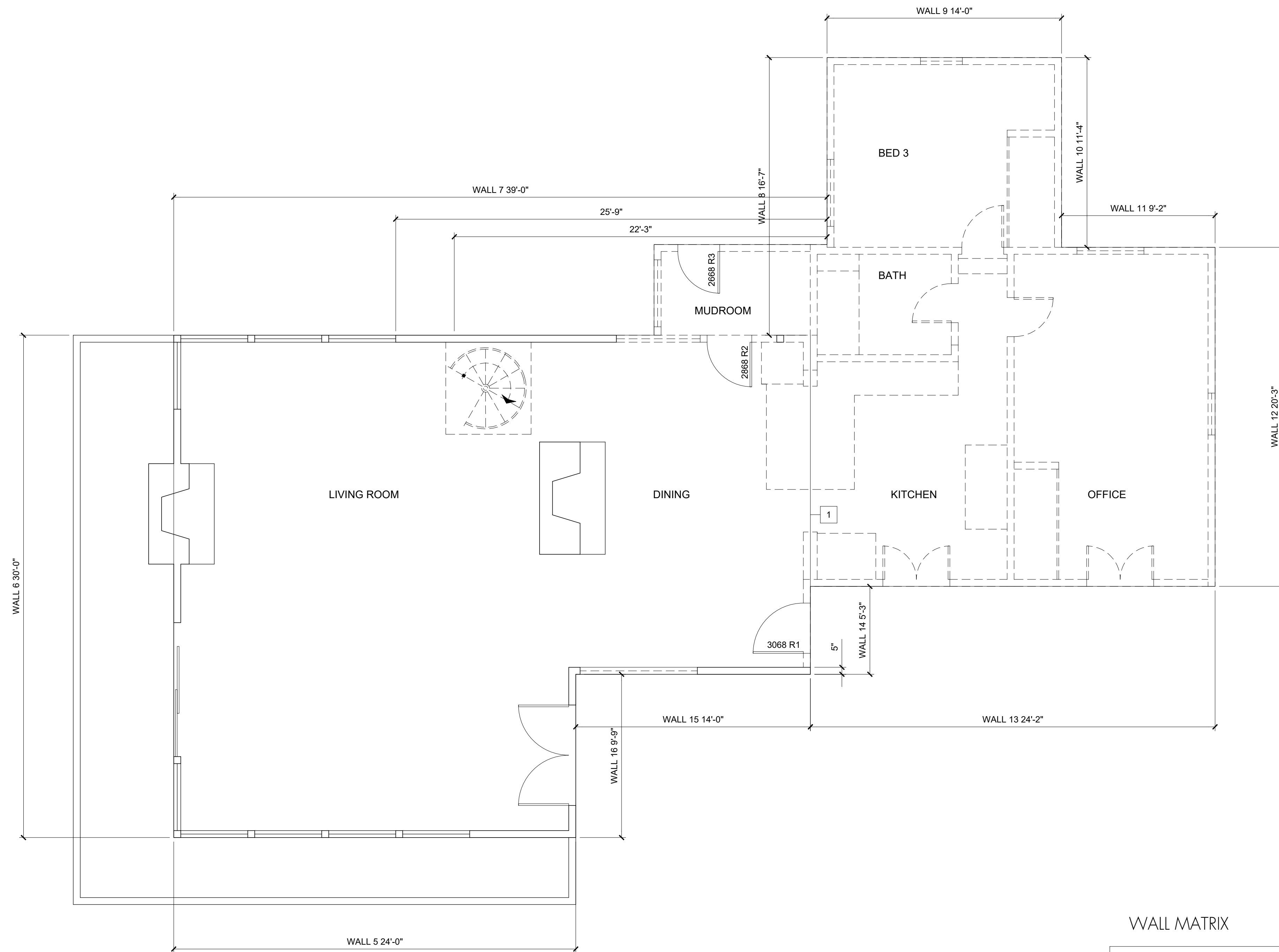
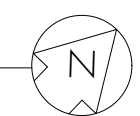

UPPER FLOOR DEMO PLAN

SCALE: 1/4" = 1'-0"

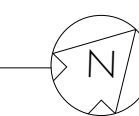

DEMO PLAN KEYNOTES

- 1 DEMO LINE - SEE SHT. A-2.2 FOR SCOPE OF EXISTING ROOF TO REMAIN

WALL LEGEND

ALL DIMENSIONS TO FACE OF FINISH U.N.O.

- EXISTING WALL TO BE REMOVED - SHORE BEARING WALLS
- REMOVE EXISTING WINDOW
- EXISTING WALL TO REMAIN

WALL MATRIX

Highland Wall Summary

Wall No.	Existing Total Wall	Demo	Wall Infill	Existing to Remain
1	22.00	0.00	0.00	22.00
2	30.25	0.00	0.00	30.25
3	22.00	0.00	0.00	22.00
4	30.00	0.00	0.00	30.00
5	24.00	0.00	0.00	24.00
6	30.00	9.50	3.25	17.25
7	39.00	22.25	0.00	16.75
8	16.58	16.58	0.00	0.00
9	14.00	14.00	0.00	0.00
10	11.33	11.33	0.00	0.00
11	9.16	9.16	0.00	0.00
12	20.25	20.25	0.00	0.00
13	24.50	24.50	0.00	0.00
14	5.25	0.42	0.00	4.83
15	14.00	0.00	0.00	14.00
16	9.75	0.00	0.00	9.75
Total	322.07	127.99	3.25	190.83
				59.3%

NO.	DATE	ISSUE
6	01/26/21	PRELIMINARY PRICING REVISED
7	02/03/21	PRELIMINARY PRICING REVISED
8	03/12/21	DRP SUBMITTAL
9	10/05/21	DRP RESUBMITTAL
10	12/15/21	DRP RESUBMITTAL

PROJECT NUMBER

19284

A-2.0



jeff parshalle architect
 p o box 230132
 encinitas ca 92023
 619 . 985 . 4099
 jeff @ jparch.net

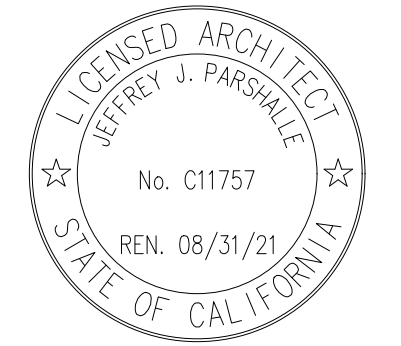

These drawings and specifications are the property and copyright of the architect and shall not be used on any other work except by agreement with the architect. Written dimensions shall take preference over scaled dimensions and shall be verified on the job site. Any discrepancy shall be brought to the notice of the architect prior to the commencement of any work.

STRINGER RESIDENCE
 1246 HIGHLAND DRIVE
 SOLANA BEACH, CA 92014

NO.	DATE	ISSUE
6	01/26/21	PRELIMINARY PRICING REVISED
7	02/03/21	PRELIMINARY PRICING REVISED
8	03/12/21	DRP SUBMITTAL
9	10/05/21	DRP RESUBMITTAL
10	12/15/21	DRP SUBMITTAL
11	02/10/22	DRP RESUBMITTAL

PROJECT NUMBER
 19284

A-2.1

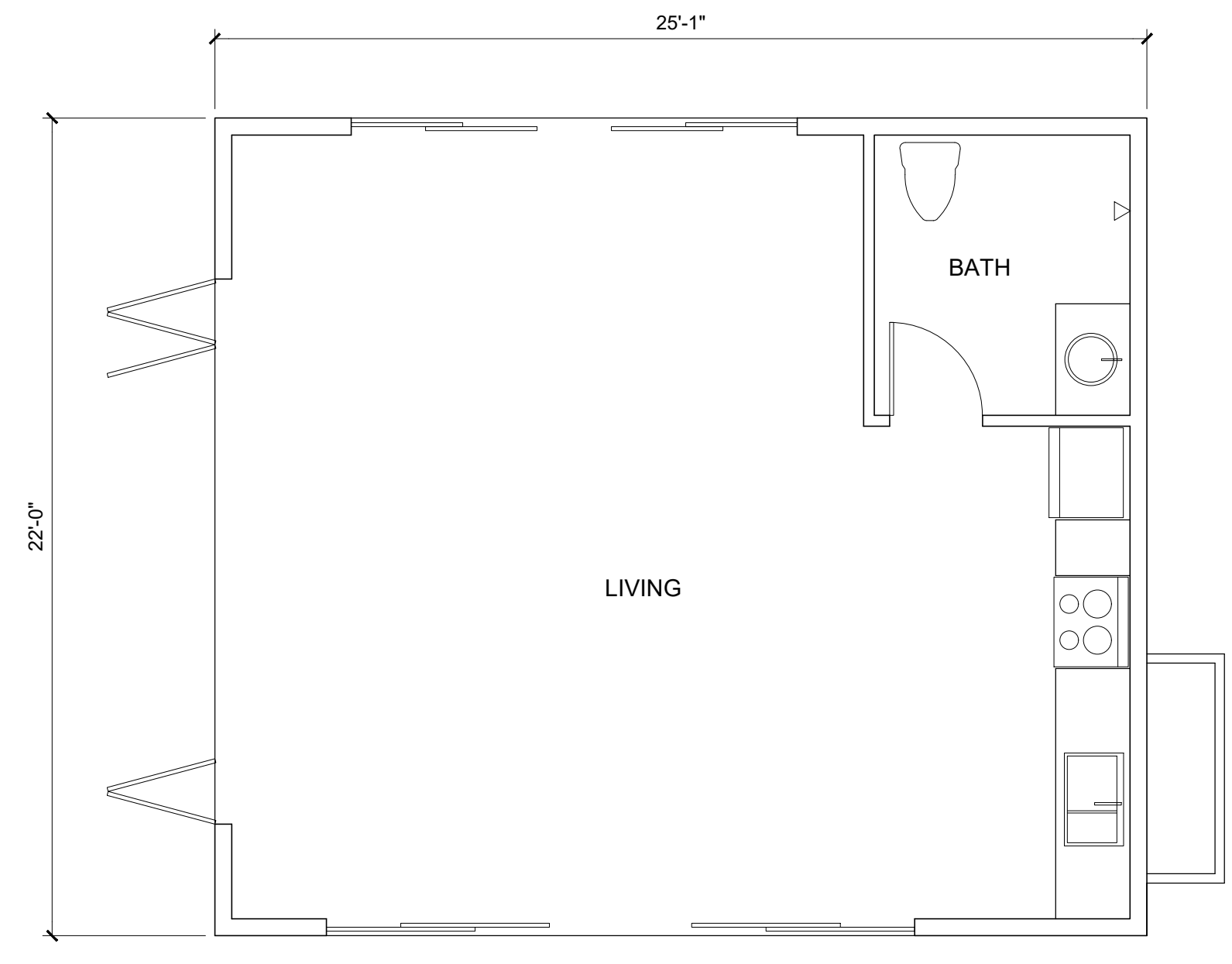

ADU FLOOR PLAN

SCALE: 1/4" = 1'-0"

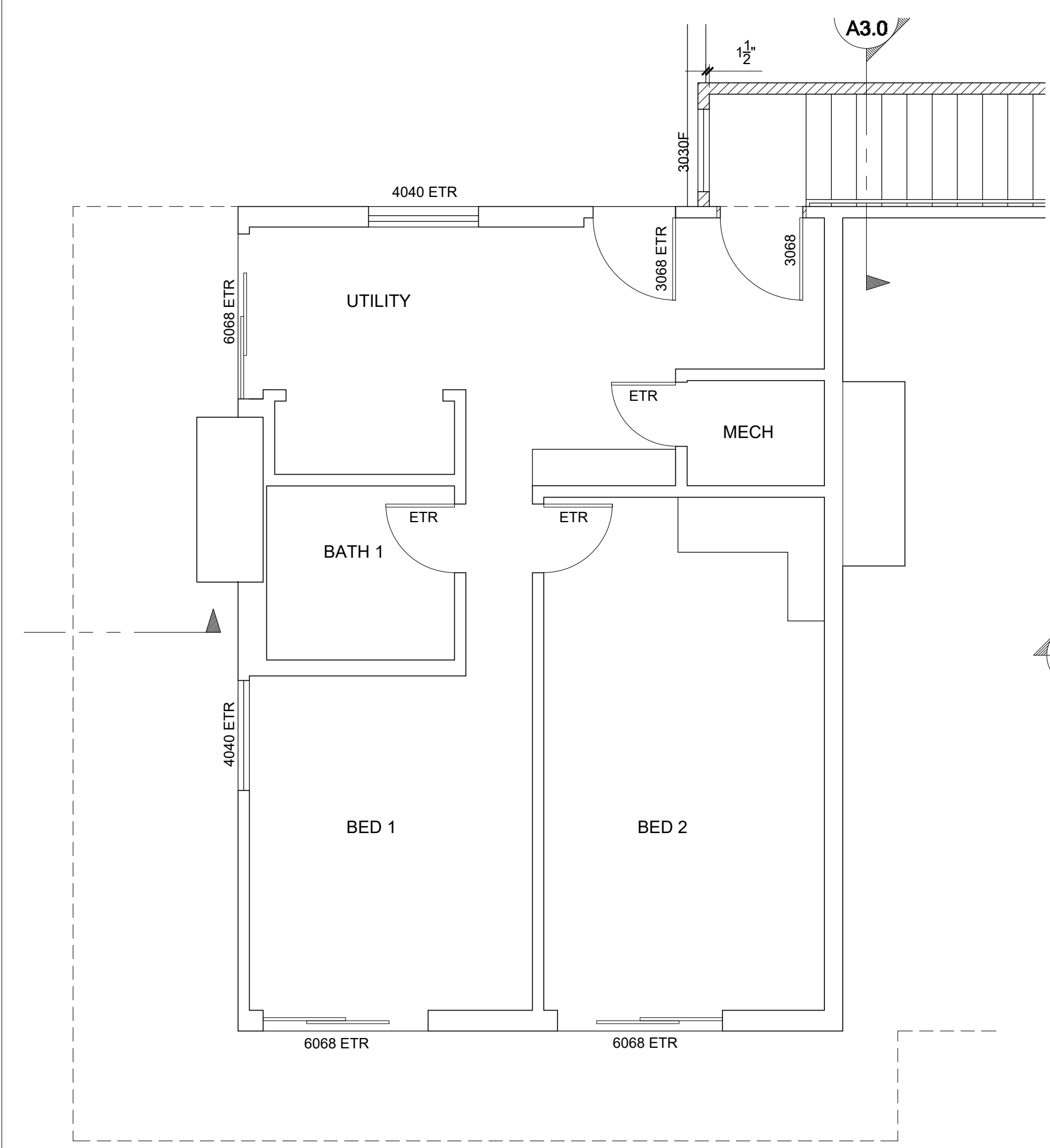

LOWER FLOOR PLAN

SCALE: 1/4" = 1'-0"

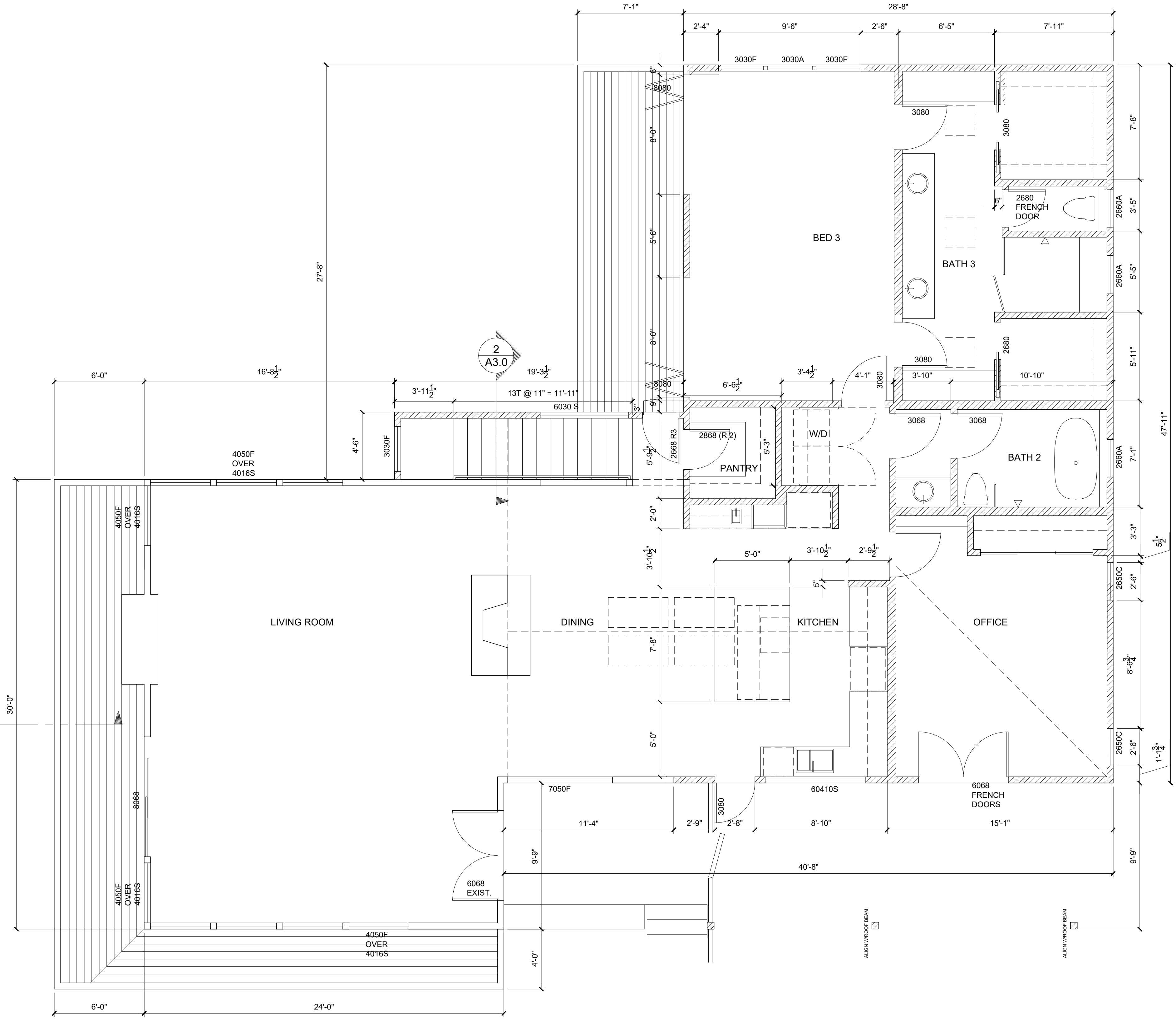

UPPER FLOOR PLAN

SCALE: 1/4" = 1'-0"

NOTE:
 BOTH MAIN RESIDENCE AND
 ADU WILL REQUIRE FIRE
 SPRINKLER SYSTEMS
 COMPLYING WITH NFPA 13D

WALL LEGEND
 ALL DIMENSIONS TO FACE OF FINISH U.N.O.

	EXISTING WALL TO REMAIN
	NEW WALL CONSTRUCTION (2X4 @ EXTERIOR U.N.O. - 2X4 @ INTERIOR) WITH 3/8" EXTERIOR GRADE PLYWOOD SHEATHING AT FULL EXTERIOR
	INFILL EXISTING WINDOW OR DOOR OPENING

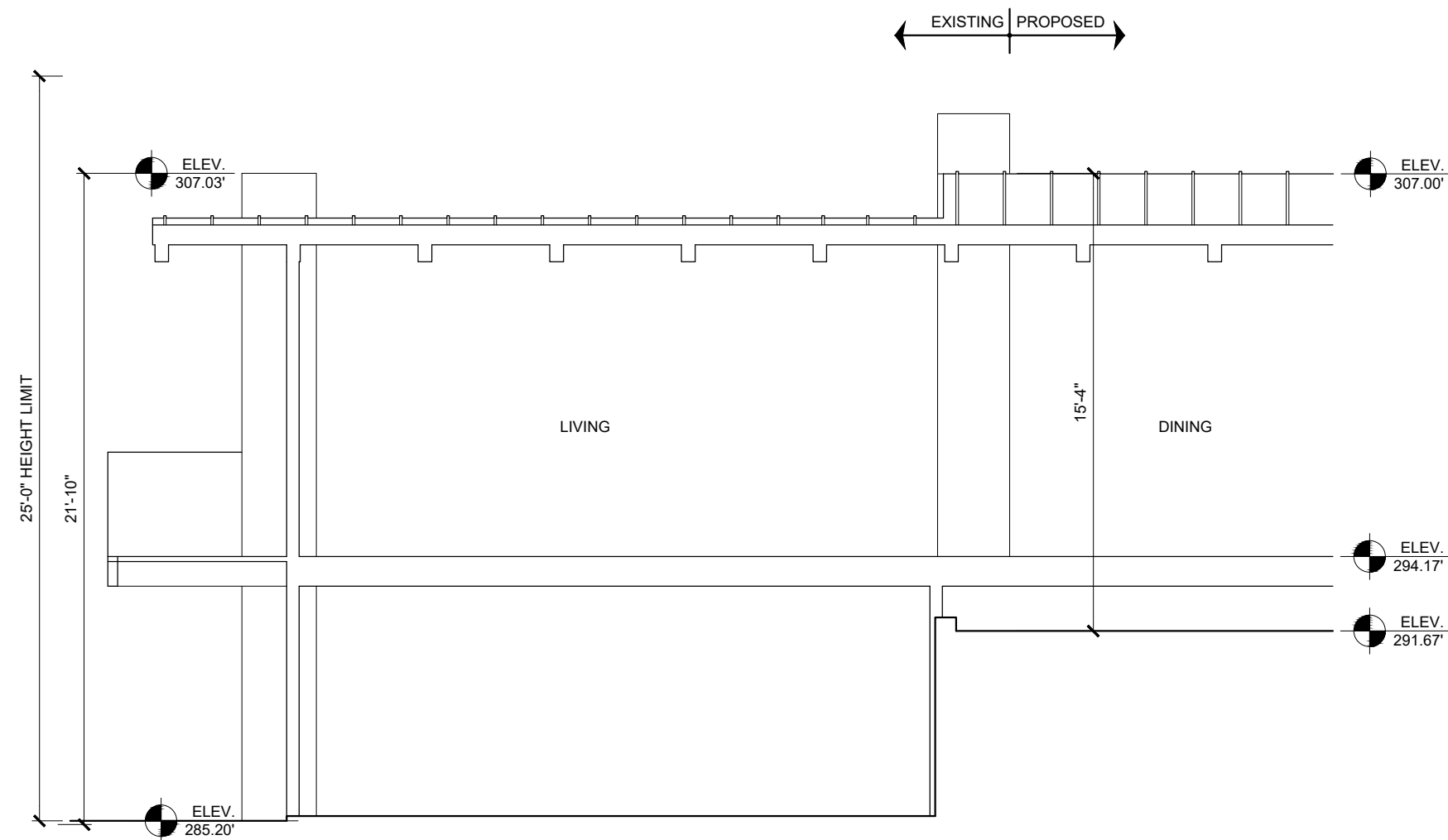

SECTION 1

3/16" = 1'-0"

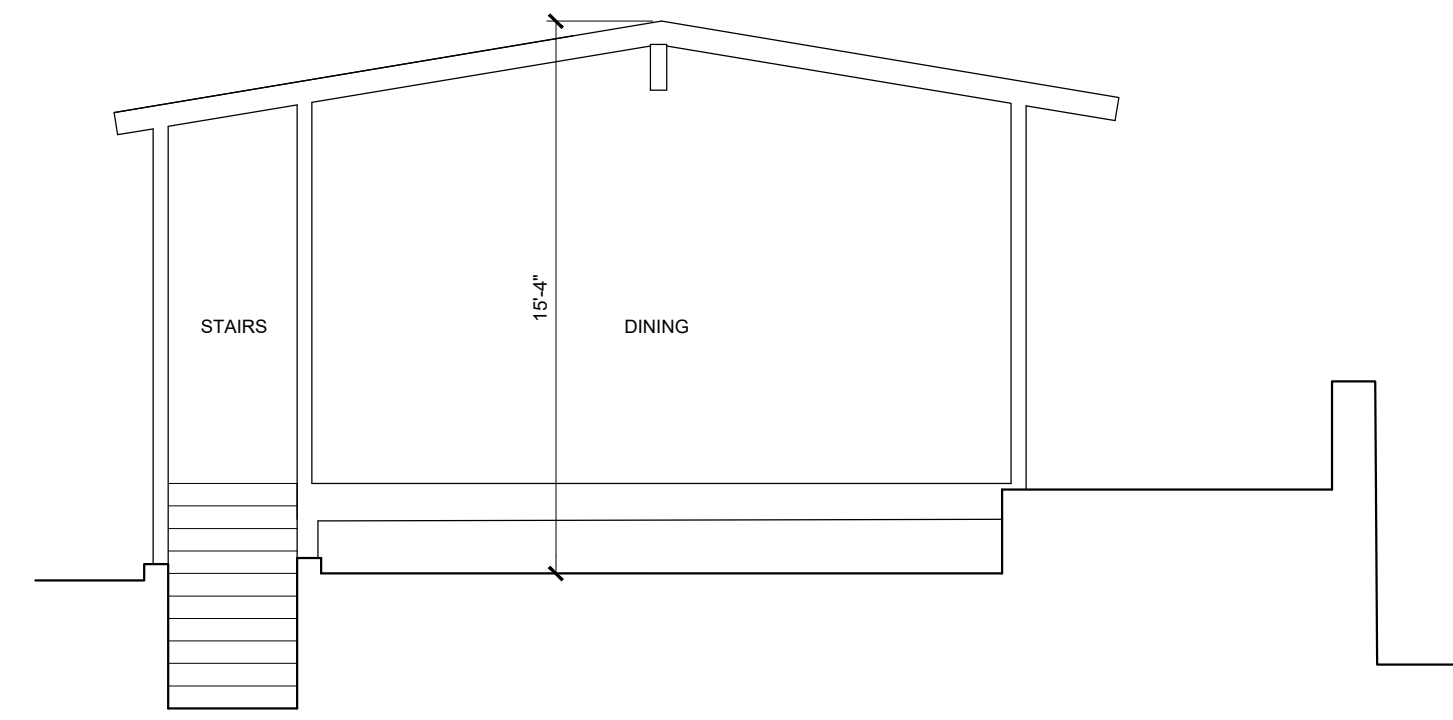

SECTION 2

3/16" = 1'-0"

ELEVATION KEYNOTES

- 1 NEW 7/8" CEMENT PLASTER - SMOOTH TEXTURE WITH ACYLIC FINISH COAT - PAINT
- 2 FIBERGLASS WINDOWS WITH INTEGRAL EXTERIOR FINISH AND PRIMED INTERIOR FINISH - DOUBLE GLAZED LOW e
- 3 FIBERGLASS SLIDING GLASS DOORS WITH INTEGRAL EXTERIOR FINISH AND PRIMED INTERIOR FINISH - DOUBLE GLAZED LOW e
- 4 CLASS A STANDING LOCK SEAM METAL ROOF O/ 3/8" PLYWD. O/ 2X DECKING - 1" RIB @ 16" O.C.

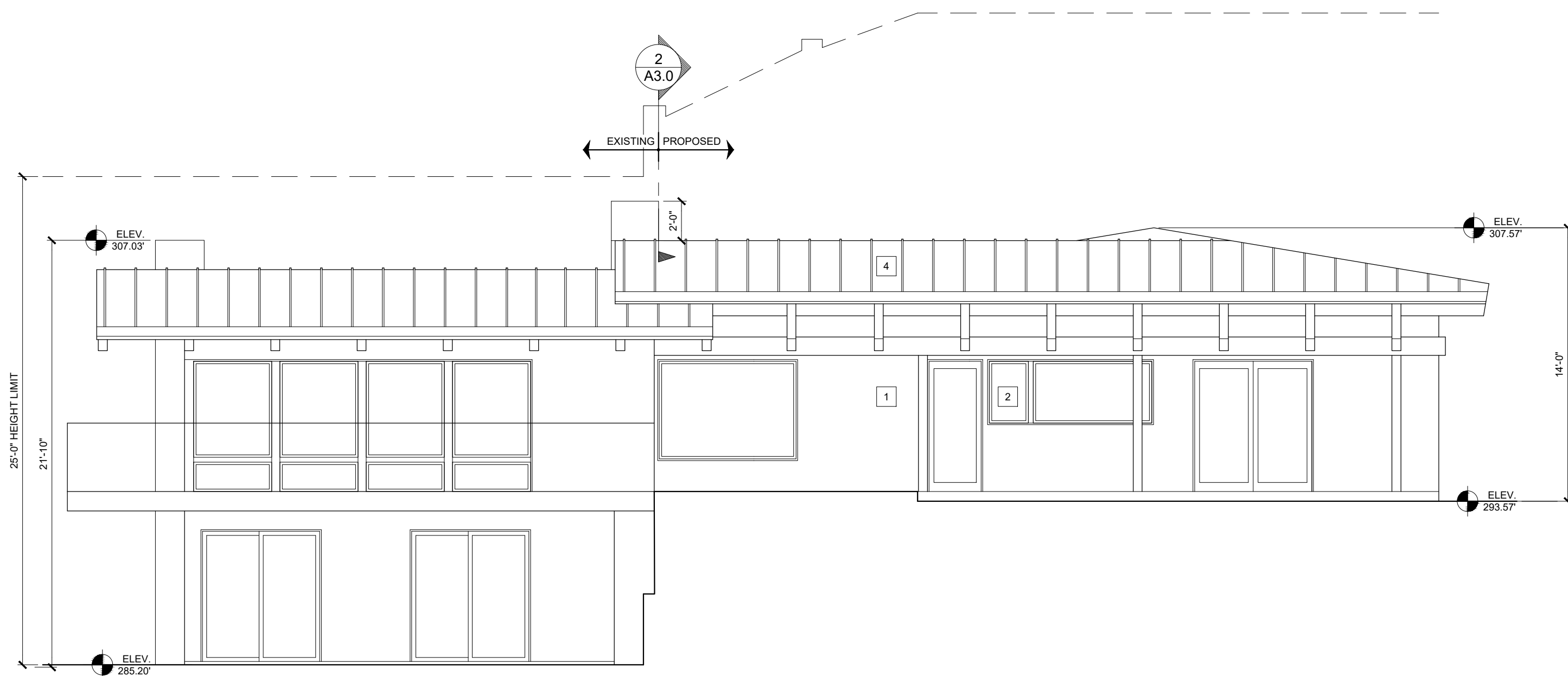

SOUTHEAST

3/16" = 1'-0"

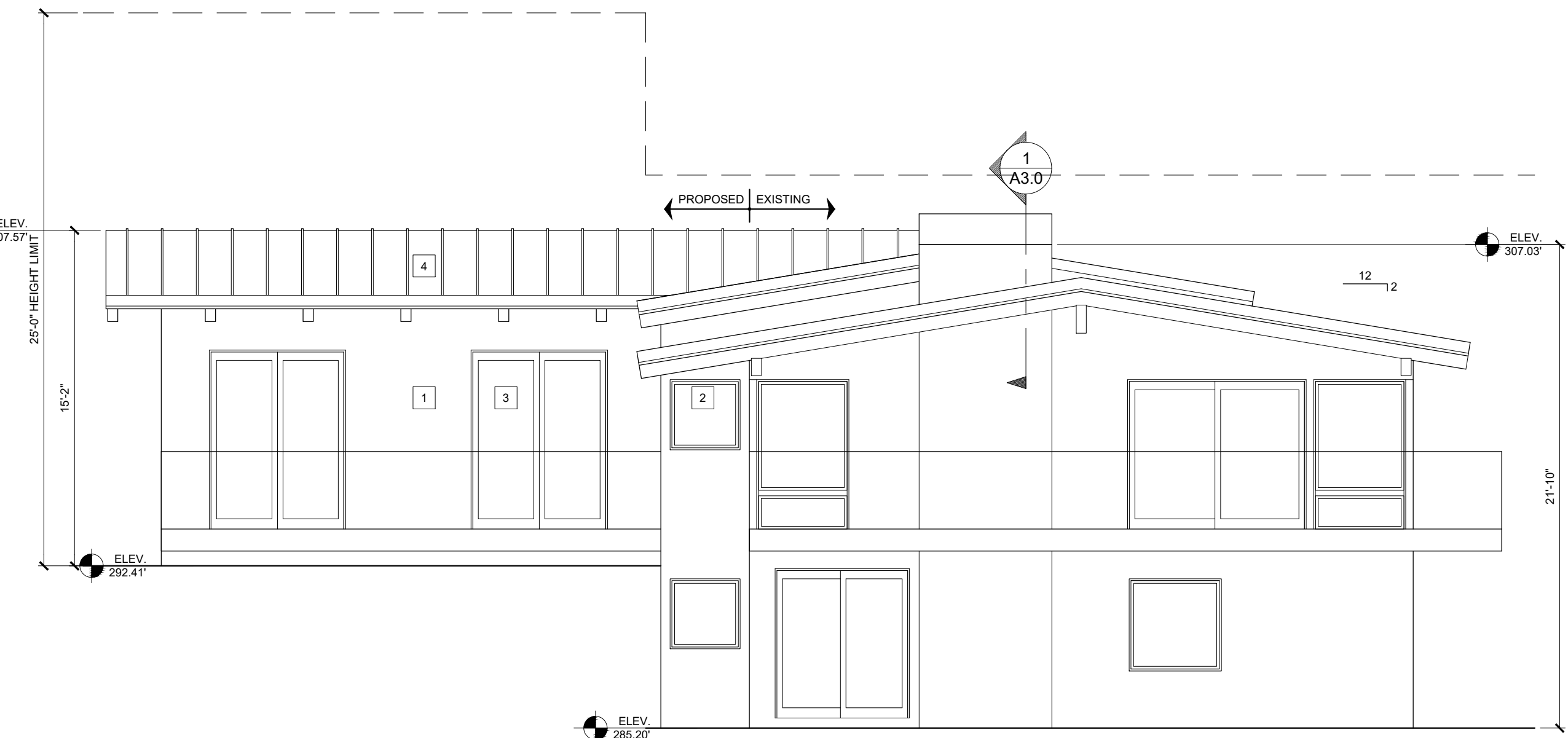

SOUTHWEST

3/16" = 1'-0"

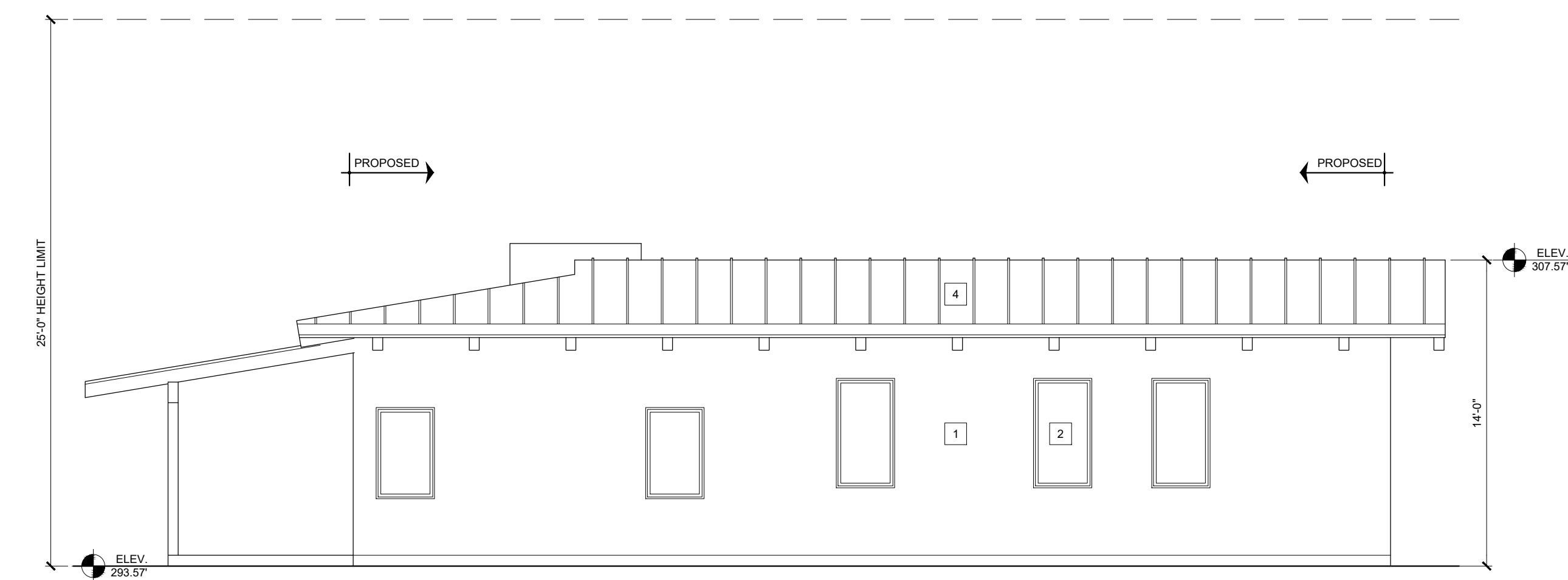

NORTHEAST

3/16" = 1'-0"

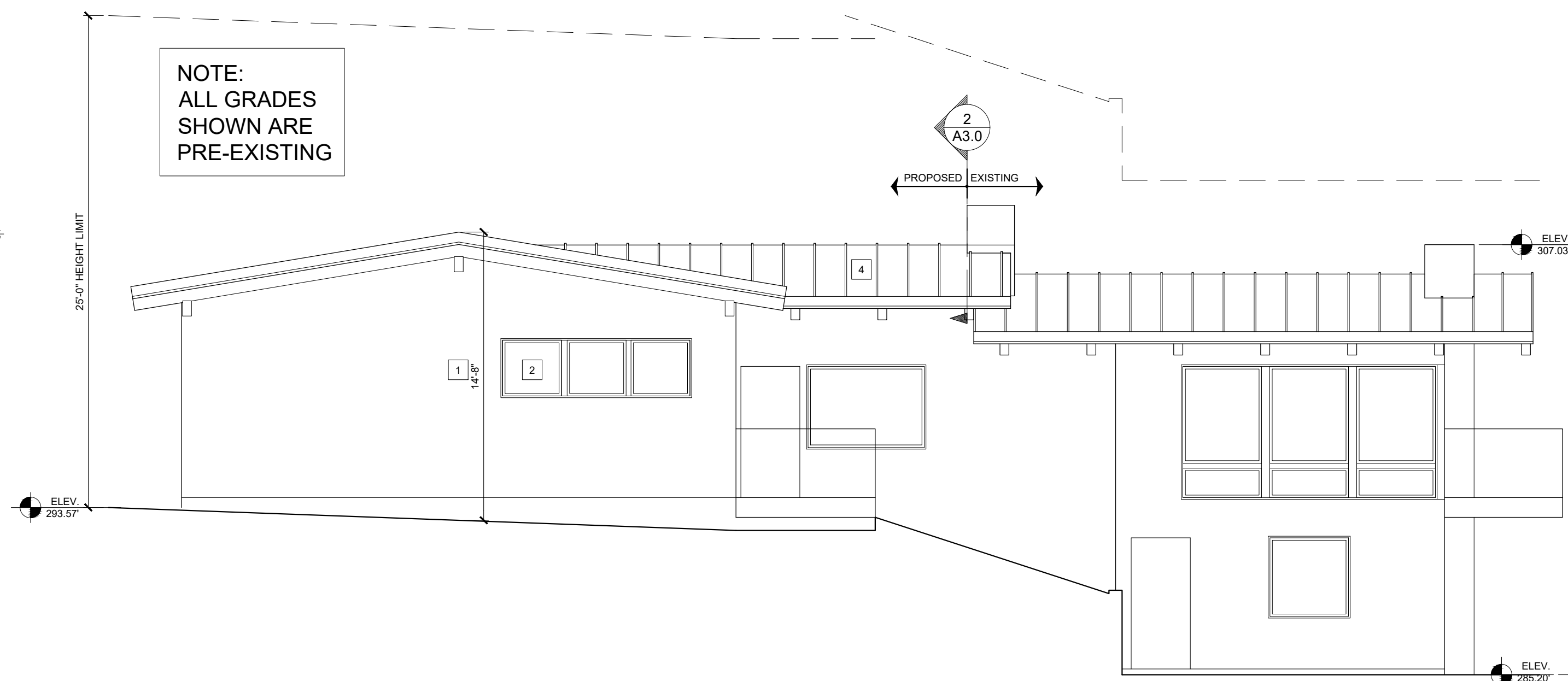

NORTHWEST

3/16" = 1'-0"

NOTE:
ALL GRADES
SHOWN ARE
PRE-EXISTING



jeff parshalle architect
p o box 230132
encinitas ca 92023
619 . 985 . 4099
jeff @ jparch.net

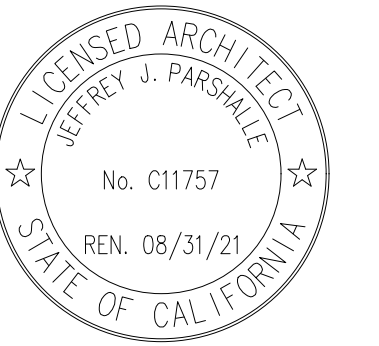

These drawings and specifications are the property and copyright of the architect and shall not be used on any other work except by agreement with the architect. Written dimensions shall take preference over scaled dimensions and shall be verified on the job site. Any discrepancy shall be brought to the notice of the architect prior to the commencement of any work.

STRINGER RESIDENCE
1246 HIGHLAND DRIVE
SOLANA BEACH, CA 92014

NO.	DATE	ISSUE
11	02/10/22	DRP RESUBMITTAL
12	03/10/22	DRP RESUBMITTAL

PROJECT NUMBER
19284

A-3.0

ELEVATION KEYNOTES

- 1 7/8" CEMENT PLASTER - SMOOTH TEXTURE WITH ACYLIC FINISH COAT
- 2 WOOD SLIDING GLASS DOORS
- 3 CLASS A STANDING LOCK SEAM METAL ROOF O/ 3/8" PLYWD. O/ 2X DECKING - 1" RIB @ 16" O.C.

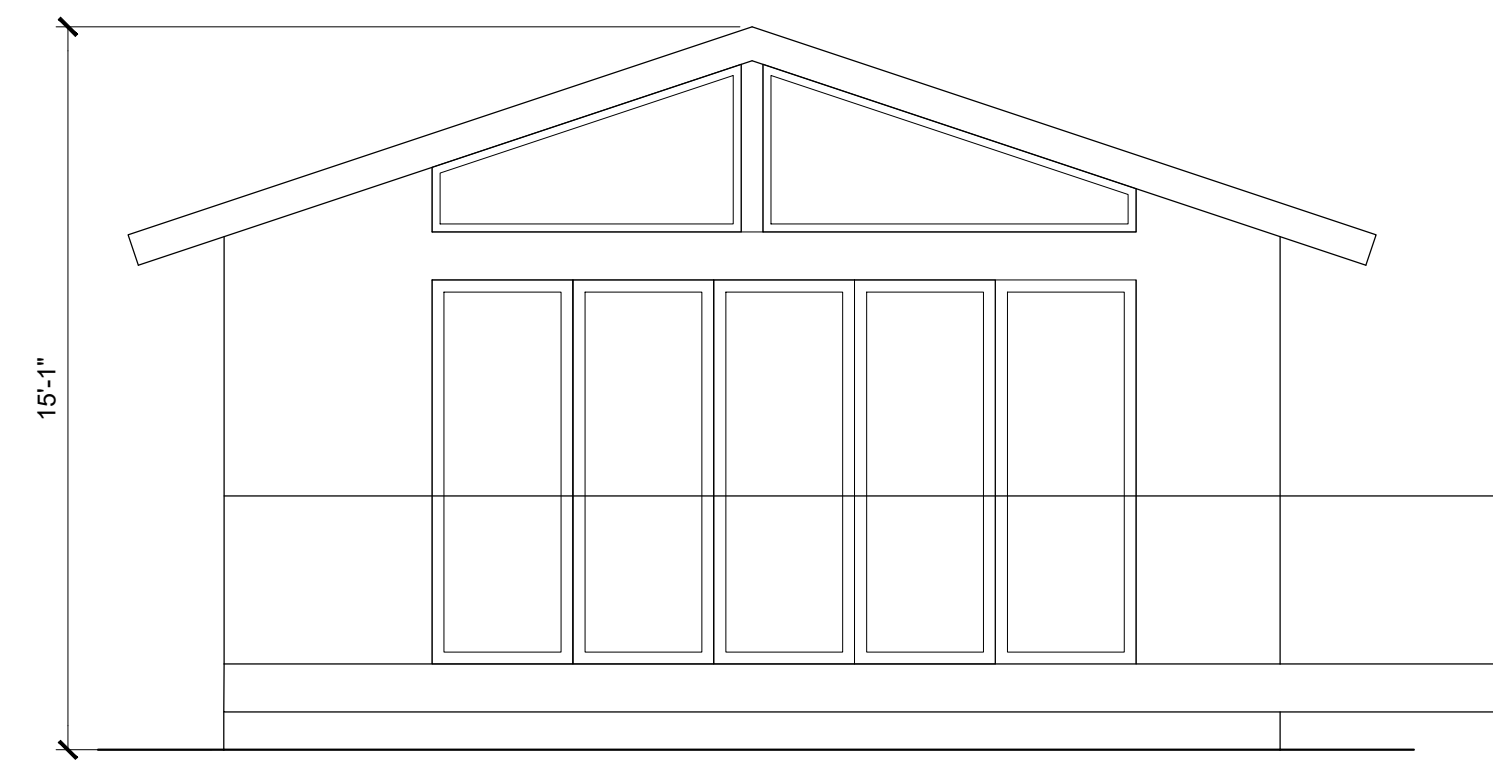

ADU SOUTHWEST 1/4" = 1'-0"

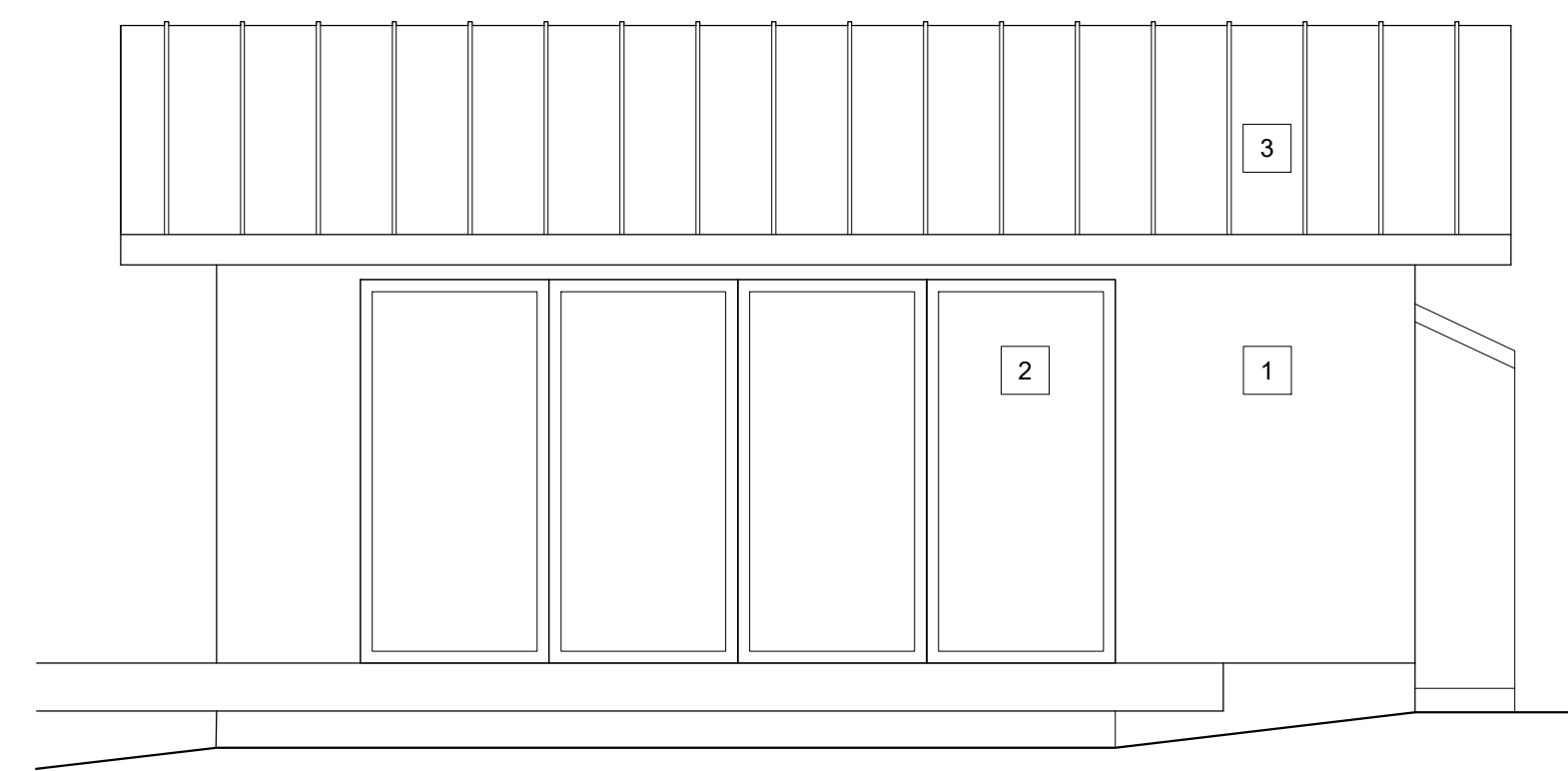

ADU SOUTHEAST 1/4" = 1'-0"

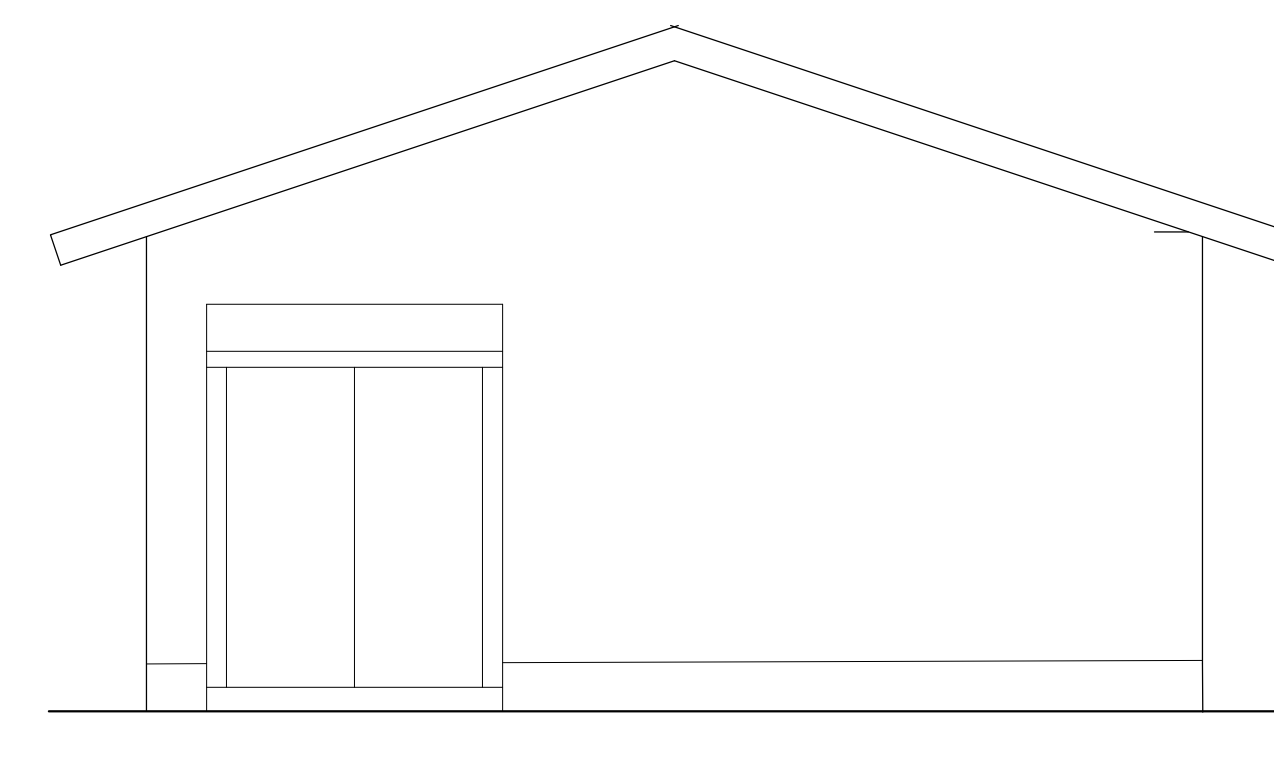

ADU NORTHEAST 1/4" = 1'-0"

NOTE:
ALL GRADES
SHOWN AT ADU
ARE PRE-EXISTING

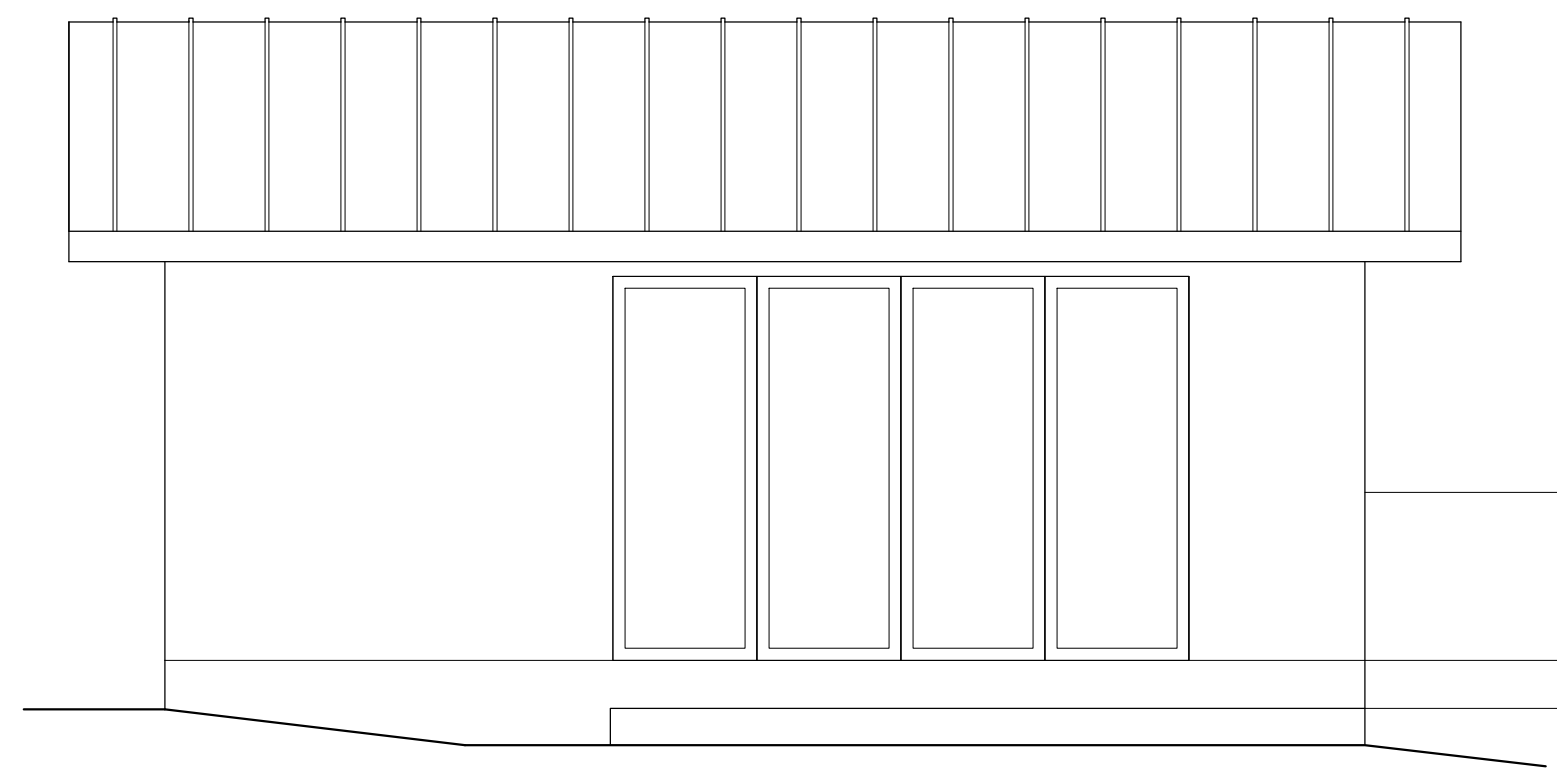

ADU NORTHWEST 1/4" = 1'-0"

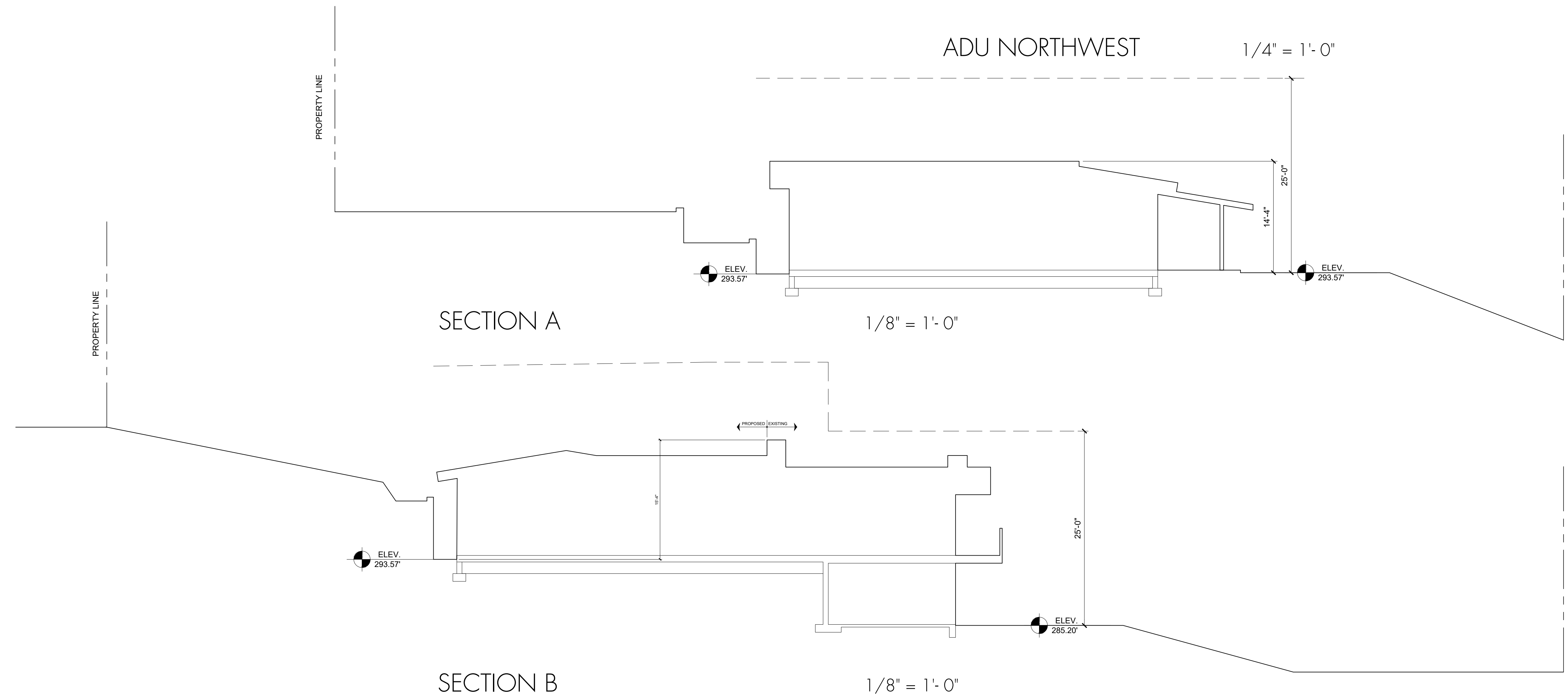

jeff parshalle architect
p o box 230132
encinitas ca 92023
619 . 985 . 4099
jeff @ jparch.net

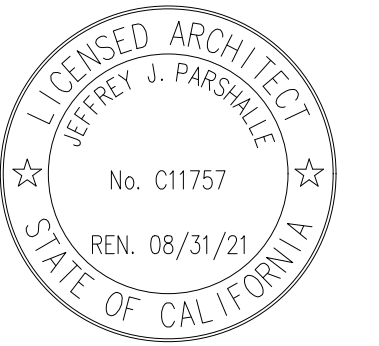

These drawings and specifications are the property and copyright of the architect and shall not be used on any other work except by agreement with the architect. Written dimensions shall take precedence over scaled dimensions and shall be verified on the job site. Any discrepancy shall be brought to the notice of the architect prior to the commencement of any work.

STRINGER RESIDENCE
1246 HIGHLAND DRIVE
SOLANA BEACH, CA 92014

NO.	DATE	ISSUE
6	01/26/21	PRELIMINARY PRICING REVISED
7	02/03/21	PRELIMINARY PRICING REVISED
8	03/12/21	DRP SUBMITTAL
9	10/05/21	DRP RESUBMITTAL
10	12/15/21	DRP RESUBMITTAL

PROJECT NUMBER
19284

PRELIMINARY GRADING PLAN

EASEMENT NOTES

- Ⓐ EXISTING I.O.D. FOR ROADWAY PURPOSES, SLOPE RIGHTS AND DRAINAGE EASEMENTS PER DOC#80-425856 O.R. REC 12-18-1980

LEGEND

- PROJECT BOUNDARY
- RIGHT OF WAY LINE
- EXISTING EASEMENT
- RESTRICTED ACCESS
- EXISTING WATER LINE
- EXISTING SEWER LINE
- EXISTING ELECTRICAL & TELEPHONE
- EXISTING RETAINING WALL
- EXISTING STORM DRAIN
- EXISTING FIRE HYDRANT
- EXISTING STREET LIGHT
- EXISTING CURB & GUTTER
- EXISTING MAJOR CONTOUR
- EXISTING MINOR CONTOUR
- EXISTING SPOT ELEVATION
- DIRECTION OF SURFACE DRAINAGE
- PROPOSED RETAINING WALL

ABBREVIATIONS:

- AC - ASPHALT CONCRETE
- CL - CENTERLINE
- DG - DECOMPOSED GRANITE
- EG - EXISTING GROUND
- FF - FINISHED FLOOR
- FS - FINISHED SURFACE
- GS - GROUND SURFACE
- R/W - RIGHT-OF-WAY
- TW - TOP OF WALL

EX. PRIVATE UTILITY EASEMENT PER DOC. NO. 1991-0000767, DOC. NO. 1991-0000768, AND DOC. NO. 1991-0000769, REC. 01-02-1991

EX. WATERLINE EASEMENT TO SANTA FE IRRIGATION DISTRICT PER DOC. NO. 81-027998, REC. 01-28-1981.

EX. PRIVATE ROAD AND UTILITY EASEMENT PER DOC. NO. 1992-00127177, REC. 03-09-1992. AND PROPOSED PRIVATE ROAD EASEMENT PER PM NO. 11063.

ENGINEER OF WORK

bha, Inc.
land planning, civil engineering, surveying
5115 AVENIDA ENCINAS
SUITE "L"
CARLSBAD, CA. 92008-4387
(760) 931-8700

RONALD L. HOLLOWAY RCE 29271 DATE

PROJECT DATA

APN: 298-370-38
PROPERTY ADDRESS: 1246 HIGHLAND DRIVE
DEL MAR, CA 92014

TOPOGRAPHY

TOPOGRAPHY BY BHA, INC.
DATE: JUNE, 18 2021

LEGAL DESCRIPTION

PARCEL 2 OF PARCEL MAP NO. 11063, BEING IN THE CITY OF SOLANA BEACH, COUNTY OF SAN DIEGO, STATE OF CALIFORNIA, RECORDED IN THE OFFICE OF THE COUNTY RECORDER OF SAN DIEGO COUNTY MARCH 5, 1981 AS FILE NO. 81-068288.

EARTHWORK

GRADING VIOLATION:
CUT: 180 CY
FILL: 90 CY
EXPORT: 90 CY

PROPOSED RIGHT-OF-WAY IMPROVEMENTS:
CUT: 58 CY
FILL: 0 CY
EXPORT: 58 CY

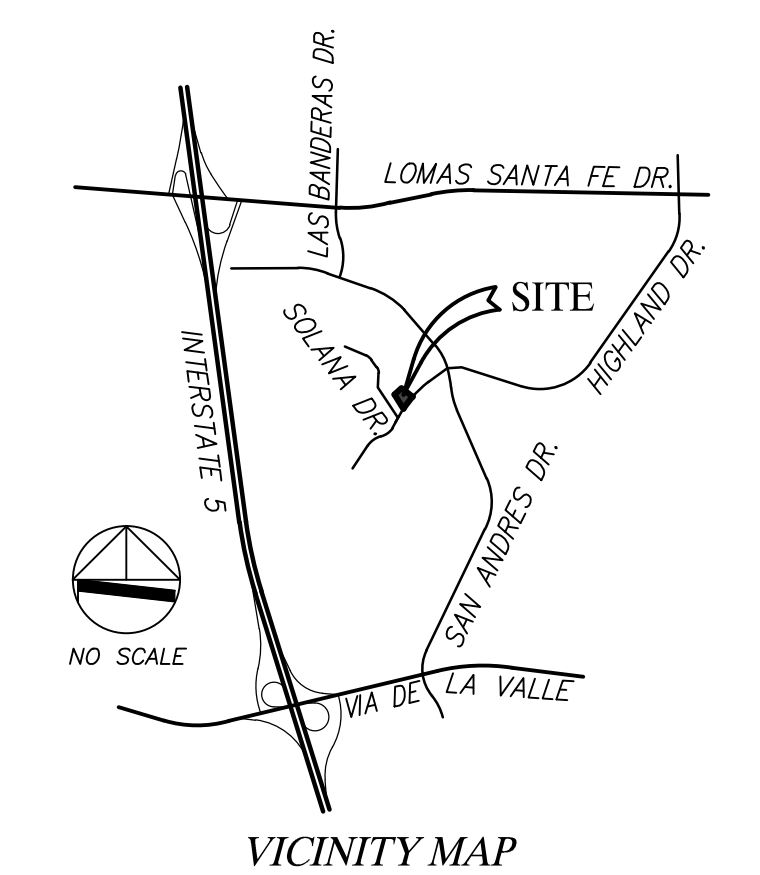
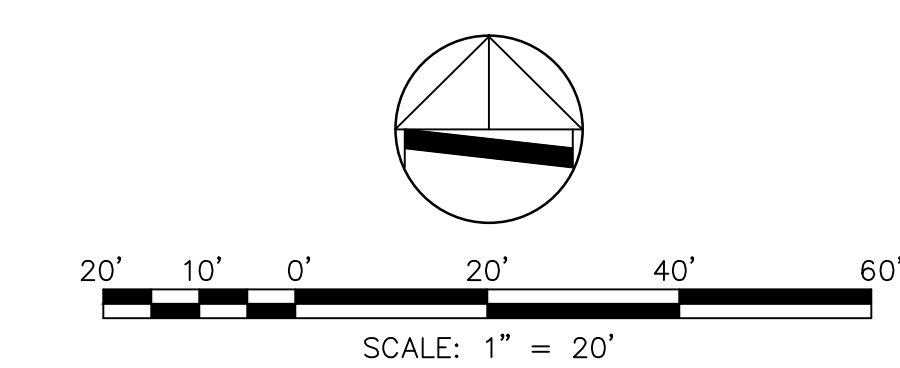
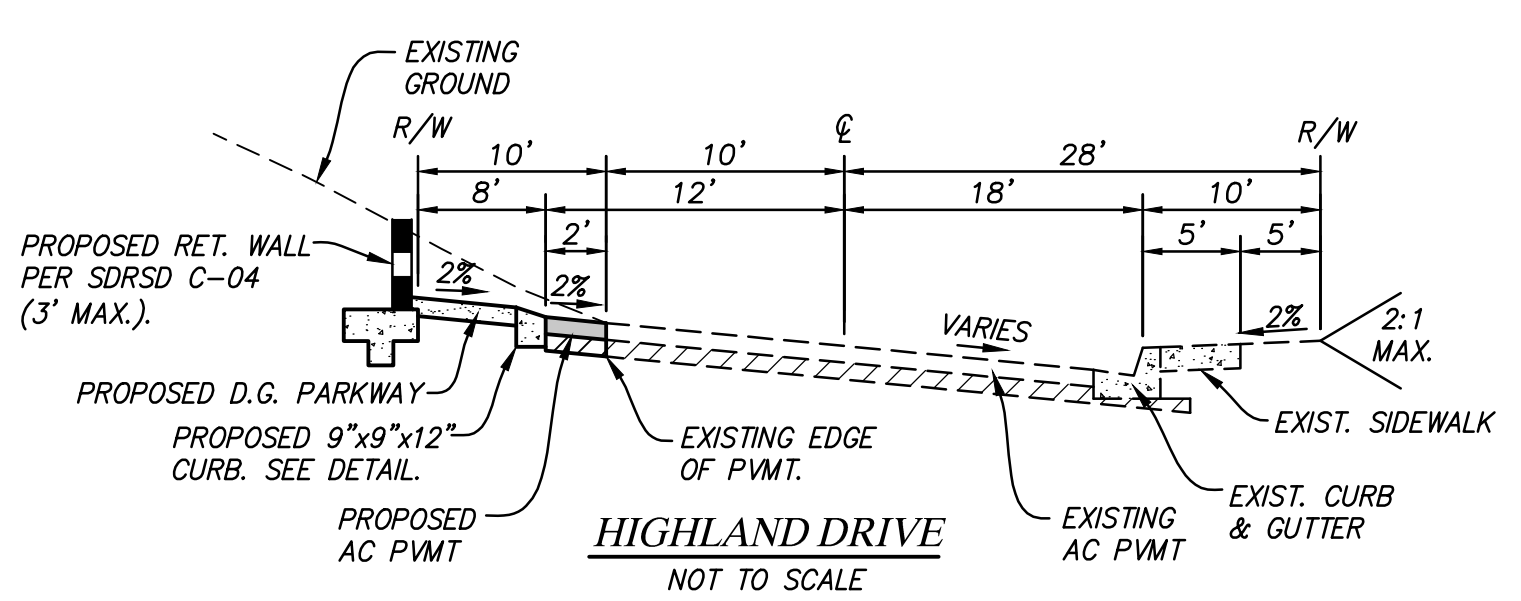
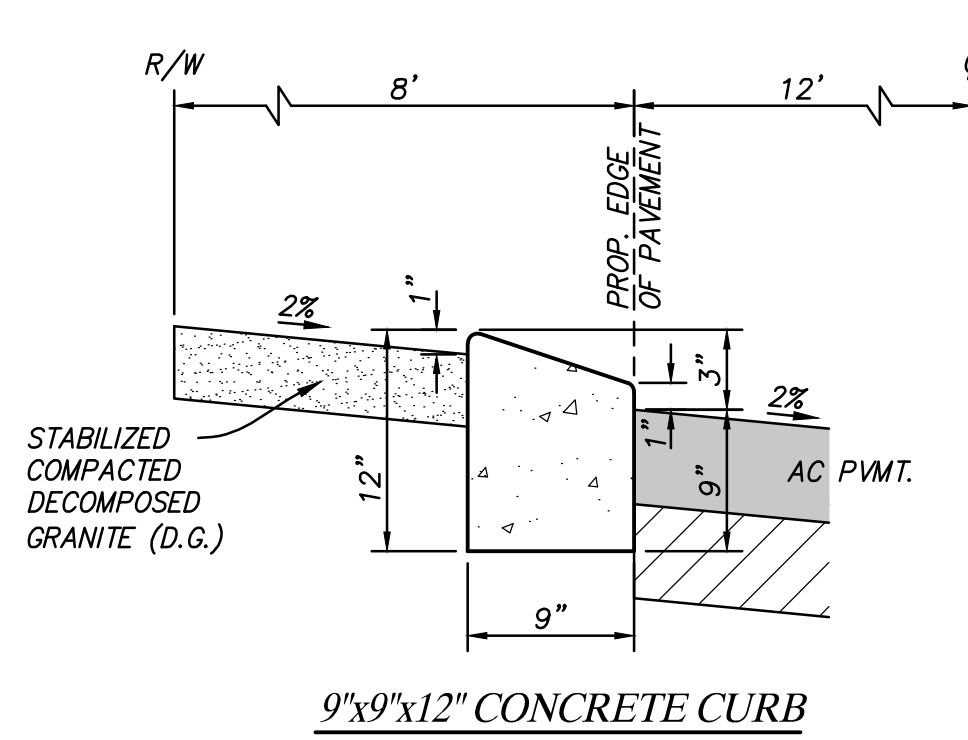
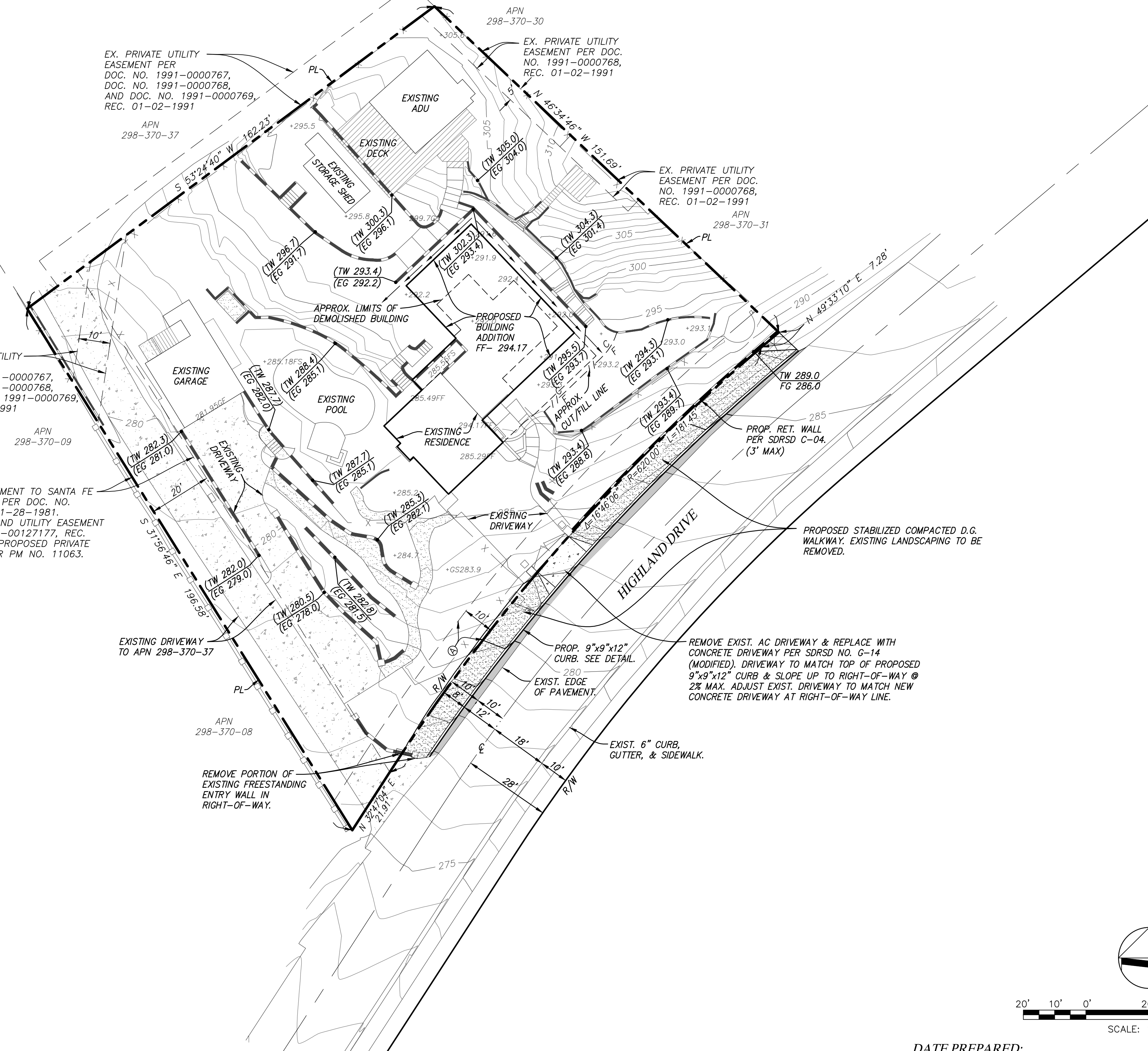

DATE PREPARED:

REV.	DESCRIPTION	DATE	APPD

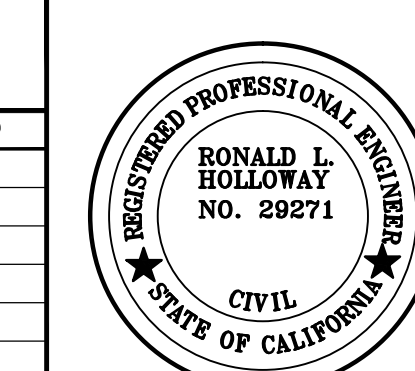

bha, Inc.
land planning, civil engineering, surveying
5115 AVENIDA ENCINAS
SUITE "L"
CARLSBAD, CA. 92008-4387
(760) 931-8700

PRELIMINARY GRADING PLAN
1246 HIGHLAND DRIVE
DEL MAR, CA 92014

K:\Civil 3D\1505\DWG\GP\1505-GP-01.dwg Dec 29, 2021 - 3:04pm

PRELIMINARY GRADING PLAN

PARCEL 2 OF MAP 11063

TOPOGRAPHIC SURVEY

PARCEL 2 OF PARCEL MAP NO. 11063

SOLANA BEACH COUNTY OF SAN DIEGO STATE OF CALIFORNIA

SURVEY BY:

LOGAN ENGINEERING
310 VIA VERA CRUZ
SAN MARCOS, CA 92078
(760) 510-3152

SURVEY DATE:

AUGUST 20, 2003

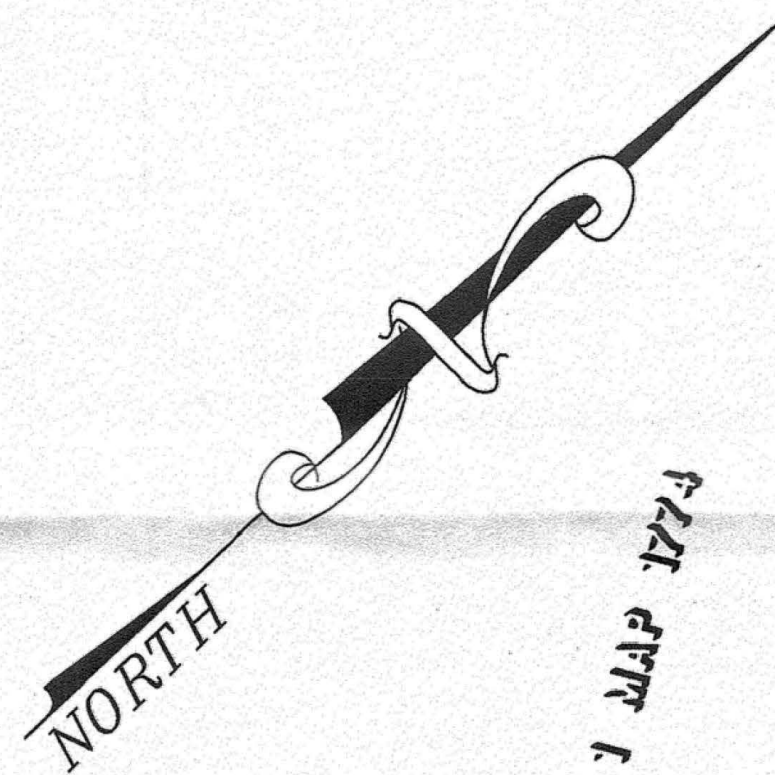
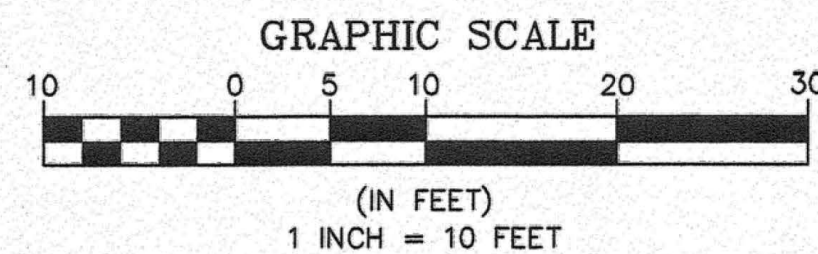

PUB. LOT 3 BLK 1 MAP 1773

PUB. LOT 1 BLK 1 MAP 11063

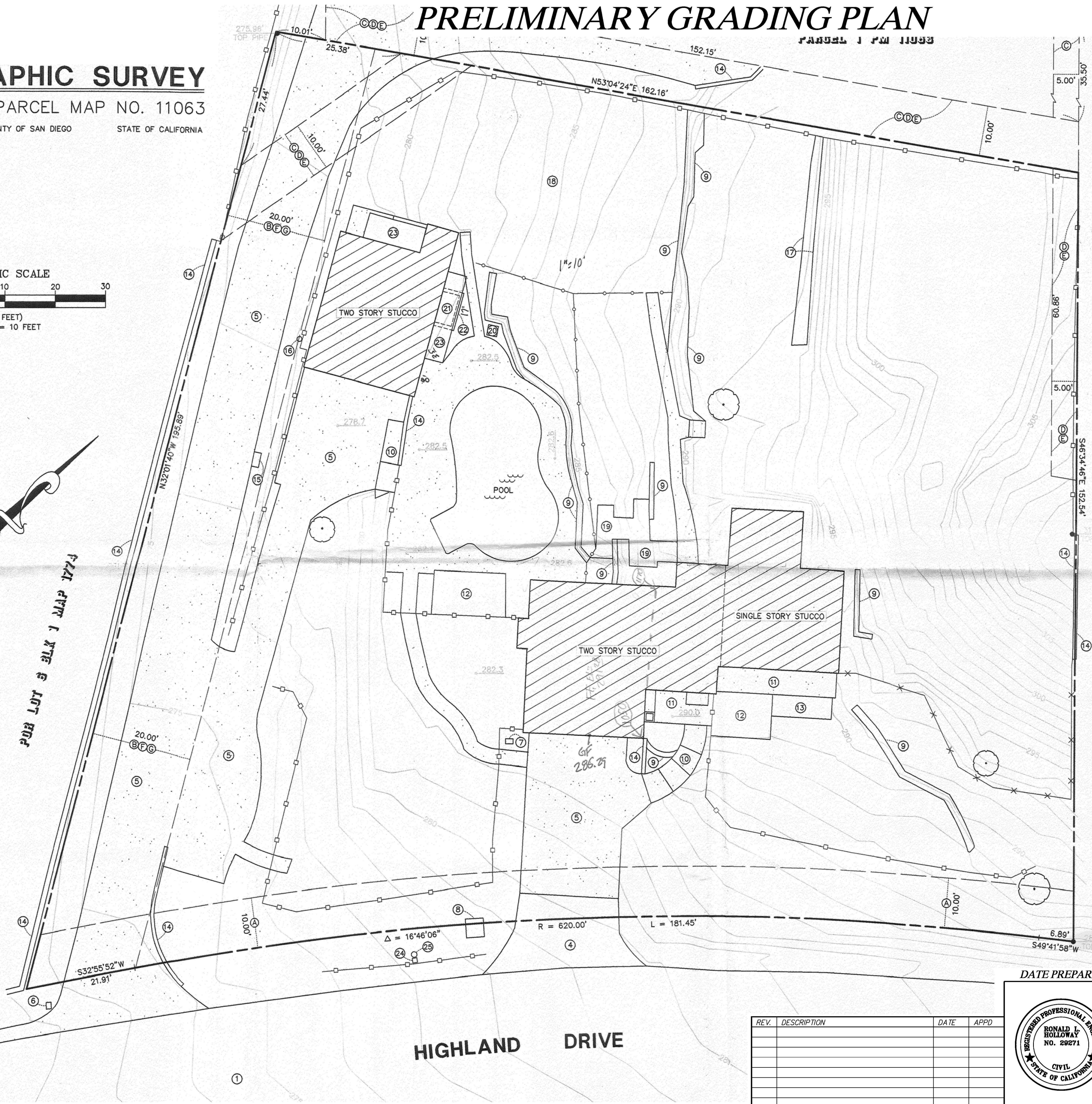

NOTES
TOPOGRAPHIC FIELD SURVEY PERFORMED JUNE 11 & 13, 2003.
CONTOUR INTERVAL EQUALS 1.0 FEET. HIGHLIGHTED AT 5' INTERVAL.
THIS MAP IS NOT A BOUNDARY SURVEY OF THE PROPERTY. BEARINGS, DISTANCES AND CURVE DATA OF THE PROPERTY BOUNDARY LINES ARE PER PARCEL MAP NO. 11063 PROTRACTED FROM FOUND MONUMENTS.

EASEMENT NOTES

- (A) EXISTING I.O.D. FOR ROADWAY PURPOSES PLUS SLOPE RIGHTS AND DRAINAGE EASEMENTS PER DOC. NO. 80-425856, O.R. REC. 12-18-80.
- (B) EXISTING EASEMENT FOR UTILITY PURPOSES GRANTED TO SANTA FE IRRIGATION DISTRICT PER DOC. NO. 81-027998, O.R. REC. 01-28-81.
- (C) EXISTING EASEMENT FOR UTILITY PURPOSES GRANTED TO BECKMAN PER DOC. NO. 91-0000767, O.R. REC. 01-02-91.
- (D) EXISTING EASEMENT FOR UTILITY PURPOSES GRANTED TO JANSSEN PER DOC. NO. 91-0000768, O.R. REC. 01-02-91.
- (E) EXISTING EASEMENT FOR UTILITY PURPOSES GRANTED TO STEPHAN PER DOC. NO. 91-0000769, O.R. REC. 01-02-91.
- (F) EXISTING EASEMENT FOR ROAD AND UTILITY PURPOSES GRANTED TO MILLER PER DOC. NO. 92-0127177, O.R. REC. 03-09-92.
- (G) PROPOSED PRIVATE ROAD EASEMENT PER PARCEL MAP NO. 11063.

EXISTING EASEMENT FOR UTILITY PURPOSES GRANTED TO SAN DIEGUITO MUTUAL WATER COMPANY PER DOC. REC. 10-30-17 IN BK 745, P. 51 OF DEEDS. LOCATION NOT PLOTTABLE FROM DOCUMENT.

EXISTING EASEMENT FOR UTILITY PURPOSES GRANTED TO MCCLURE PER DOC. REC. 12-07-27 IN BK 1430, P. 51 OF DEEDS. LOCATION NOT PLOTTABLE FROM DOCUMENT.

RIGHT TO EXTEND DRAINAGE STRUCTURES AND EMBANKMENT SLOPES PER ROAD SURVEY NO. 821 REC. 04-21-49 IN BK. 3179, P. 154, O.R. LOCATION NOT SHOWN ON PM 11063.

LEGEND

- ① ASPHALT PAVED STREET
- ② CONCRETE ROLL-OVER CURB & GUTTER
- ③ CONCRETE CURB
- ④ ASPHALT PAVED DRIVEWAY APPROACH
- ⑤ CONCRETE DRIVEWAY
- ⑥ WATER METER
- ⑦ GAS METER
- ⑧ ELECTRIC TRANSFORMER
- ⑨ ROCK RETAINING WALL
- ⑩ CONCRETE STEPS
- ⑪ CONCRETE PORCH
- ⑫ WOOD DECK
- ⑬ TILE WALKWAY
- ⑭ CONCRETE BLOCK RETAINING WALL
- ⑮ ELECTRIC JUNCTION BOX
- ⑯ SEWER CLEANOUT
- ⑰ WOODEN RETAINING WALL
- ⑱ AREA TERRACED
- ⑲ WOODEN STEPS/LANDINGS
- ⑳ POOL MAINTENANCE APPURTENANCES
- ㉑ POOL MAINTENANCE APPURTENANCES UNDER STAIRS
- ㉒ CONCRETE BLOCK WALL
- ㉓ WOOD STAIRS
- ㉔ TELEPHONE JUNCTION BOX
- ㉕ CABLE TV JUNCTION BOX

— PROPERTY LINE
 - - - 5' CONTOUR LINE LABELED
 - - - 1' CONTOUR LINE
 x x x WIRE FENCE
 □ WOOD FENCE
 ○ CHAIN LINK FENCE
 ▭ SPOT ELEVATION OF EXISTING SURFACE
 ▨ CONCRETE SURFACE
 ○ LARGE PALM TREE (2'-4' TRUNK DIAMETER)

HIGHLAND DRIVE

DATE PREPARED:

REV.	DESCRIPTION	DATE	APPD.



bha, Inc.
land planning, civil engineering, surveying
5115 AVENIDA ENCINAS
SUITE "L"
CARLSBAD, CA. 92008-4387
(760) 931-8700

PRELIMINARY GRADING PLAN
1246 HIGHLAND DRIVE
DEL MAR, CA 92014

K:\Civil 3D\1505\DWG\GP\ 1505-GP-01.dwg Oct 01, 2021 - 7:40am

FOUNDATION PLAN

1/4" = 1'-0"

SEE SECTION A-3 BELOW FOR FOOTING DETAILS.

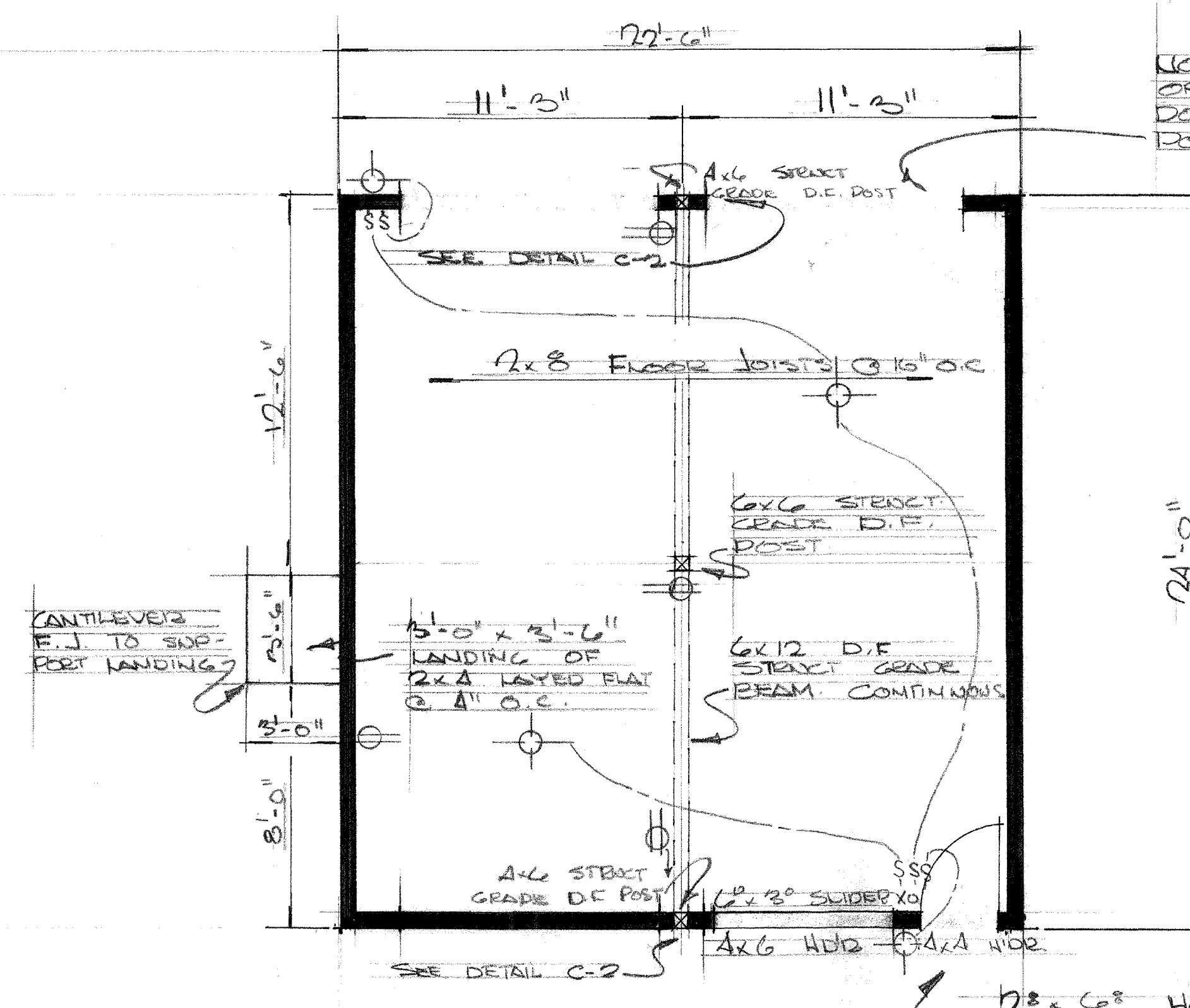
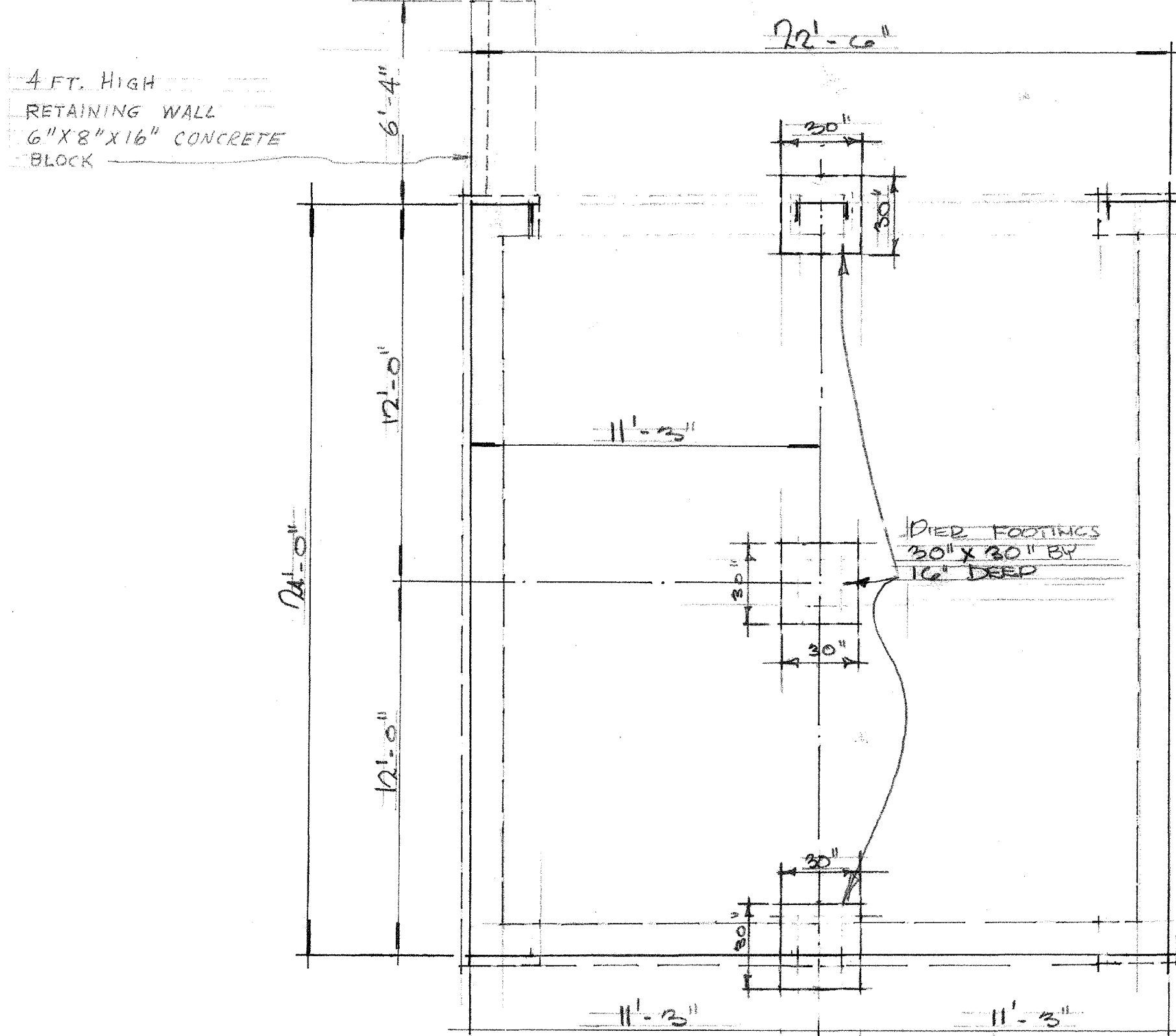

NOTE: FRAME GARAGE DOOR OPENINGS TO RECEIVE DOORS PRESENTLY IN THE POSSESSION OF OWNER

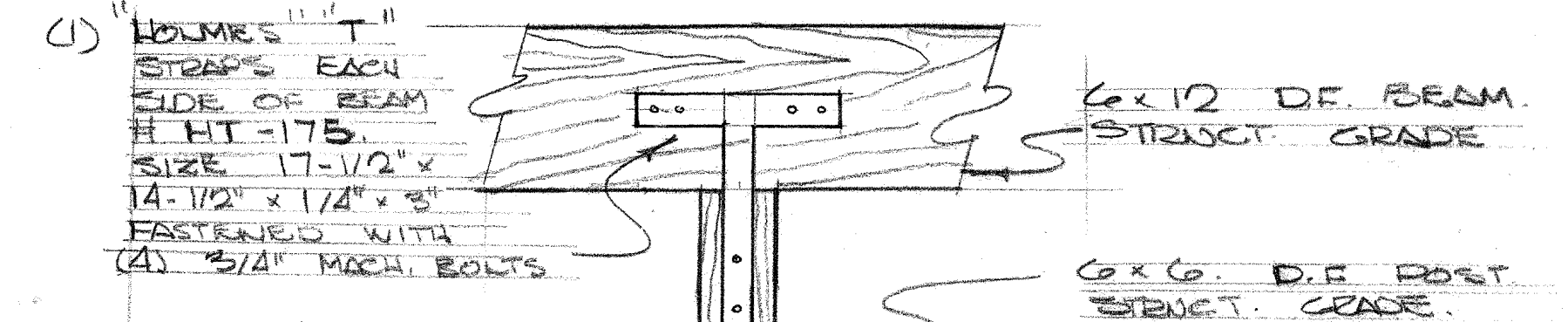

B
2

POST TO BEAM CONNECTION AT MID-SPAN

1'-0"

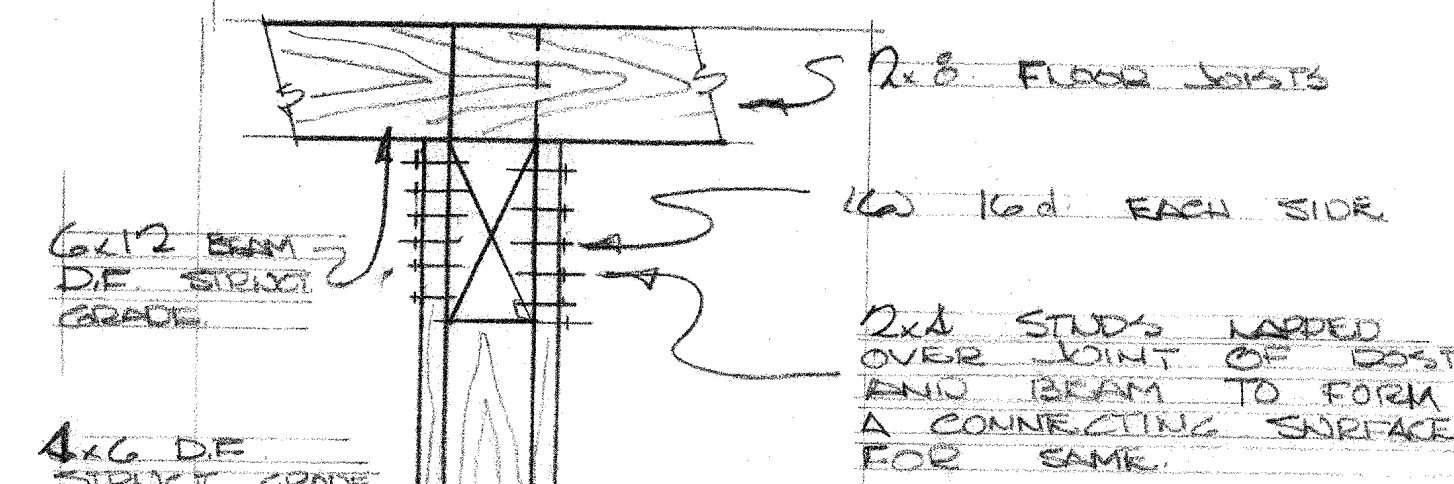

C
2

POST TO BEAM CONNECTION AT END POST SUPPORTS

1'-0"

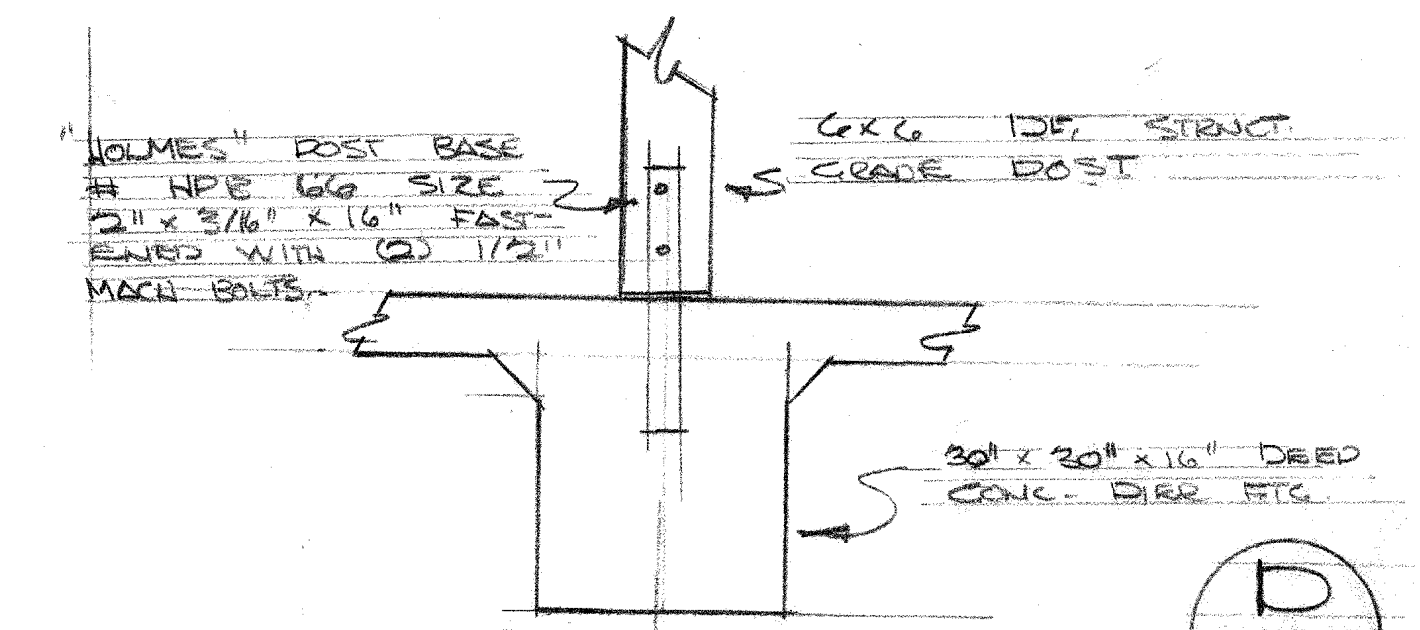

D
2

SHEET 4 OF 5

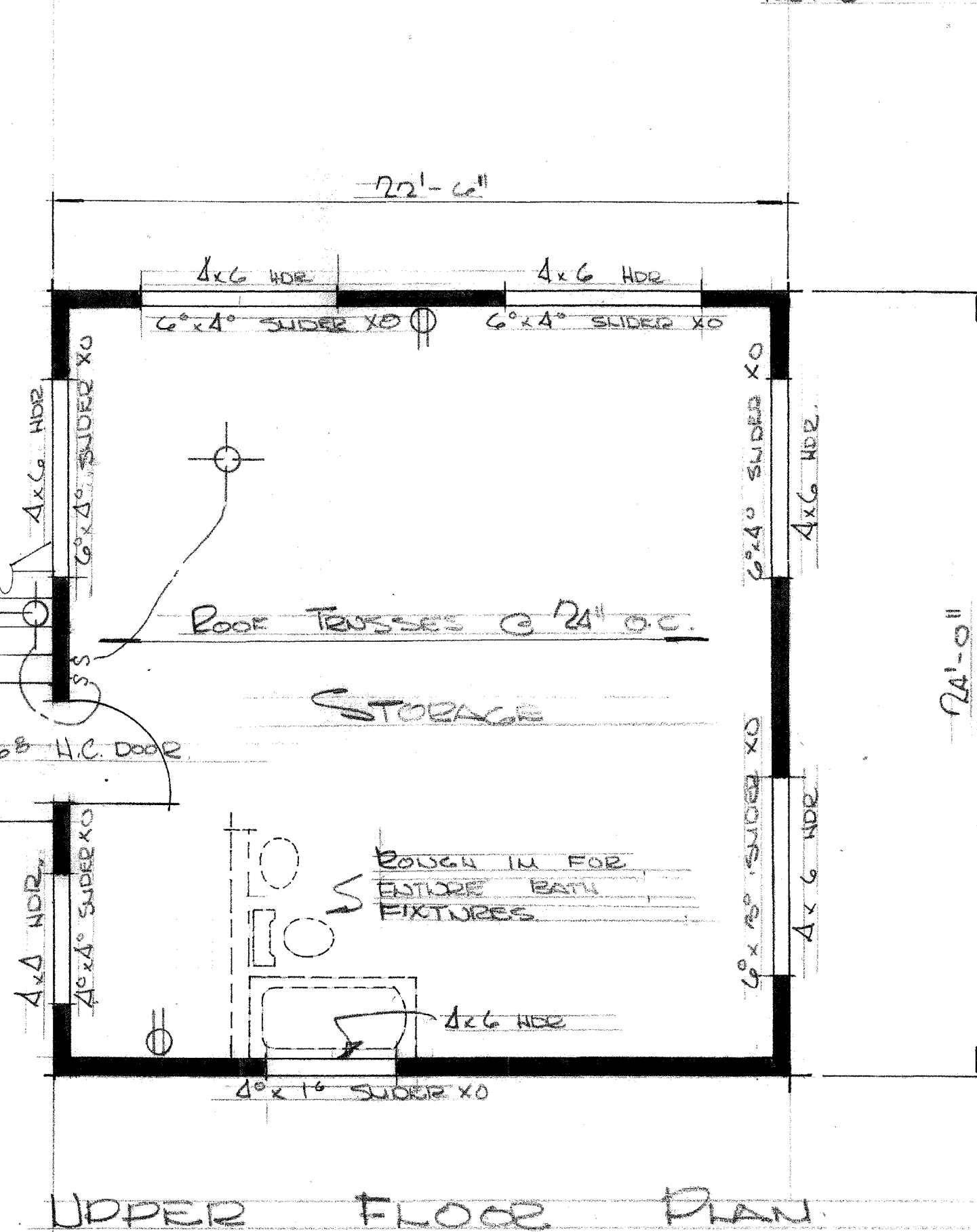
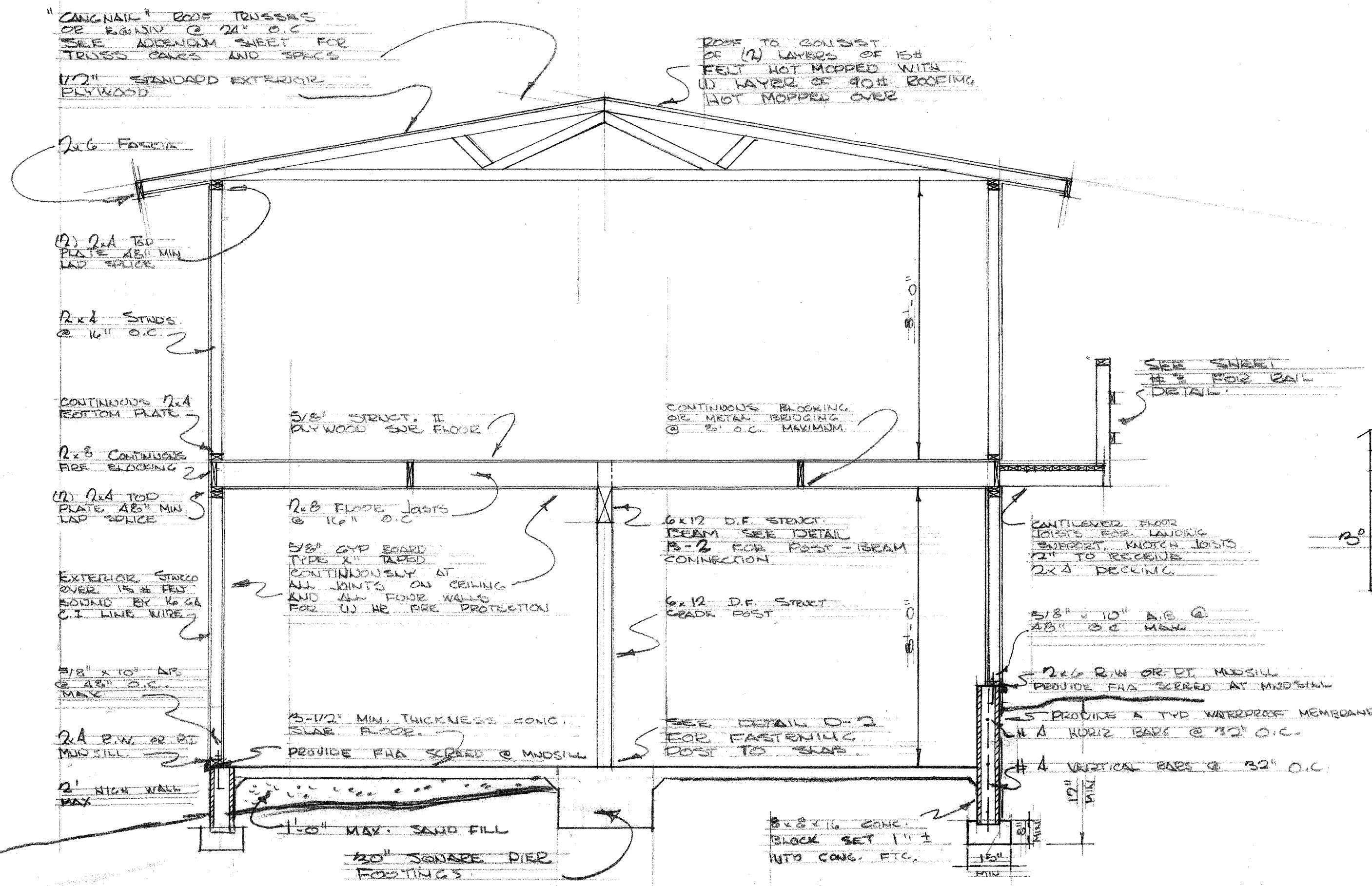

UPPER FLOOR PLAN

1/4" = 1'-0"

STRUCT SECTION

3/8" = 1'-0"

SOLID GROUT OR GRK WHERE THERE EXISTS VERTICAL RE-BARS

PREFAB SHUTTERS
SIZE 15.0" x 4.0"

ROOF (2) LAYERS OF
1/2" G. FIBER HOT MAPPED
ONE LAYER OF 3/8" G.
ROOFING HOT MAPPED

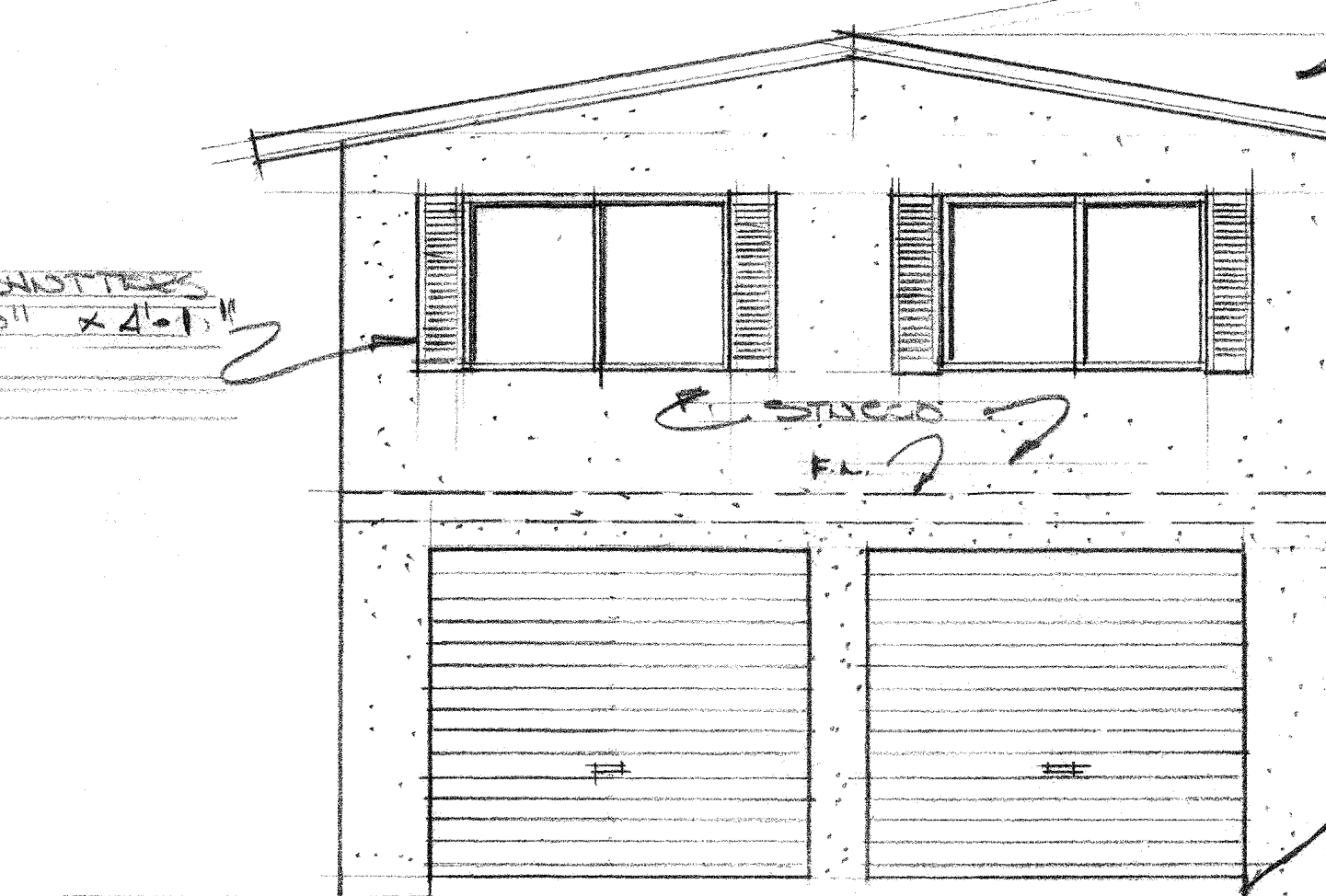

FRONT

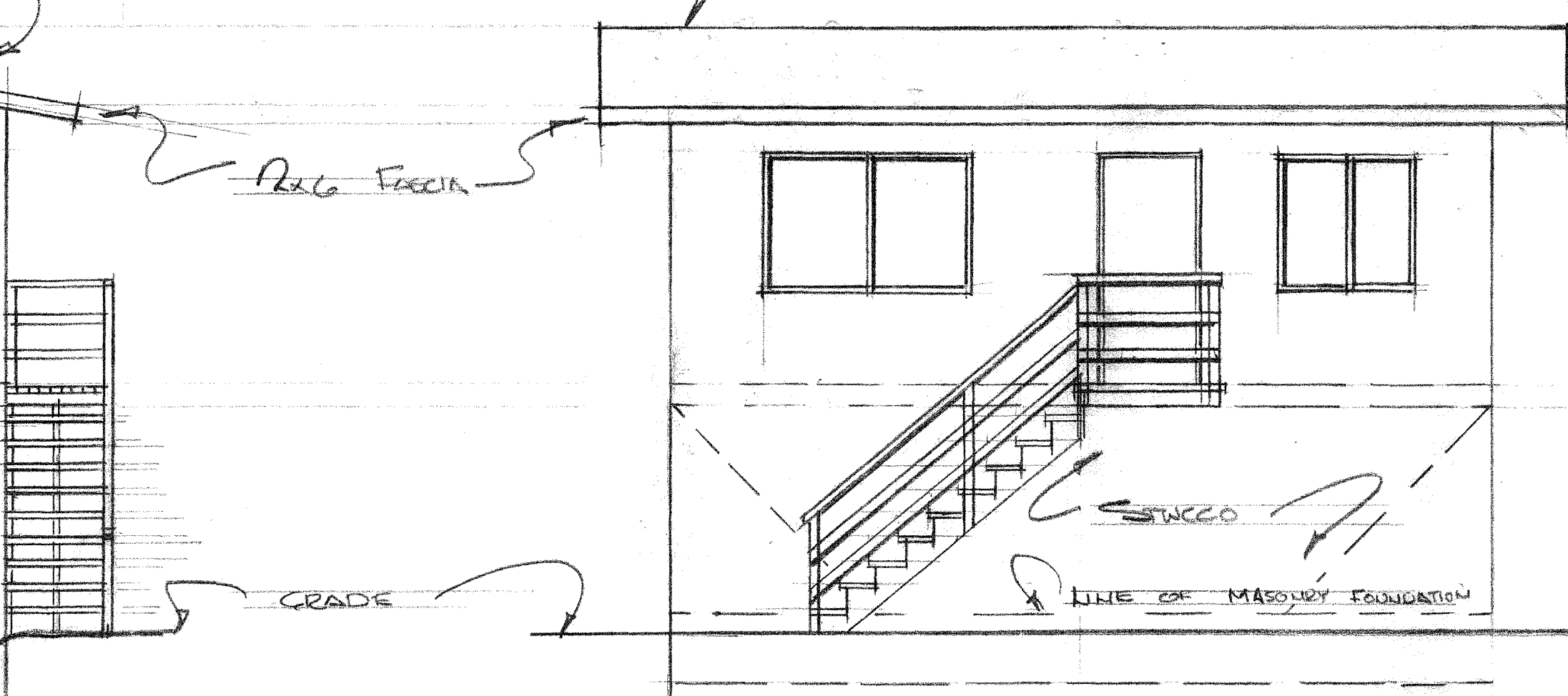

RIGHT SIDE

NOTE:
STAIRS TO BE FABRICATED
WITH (2) 2x12 STRINGERS
FASTENED TO LANDING
WITH JOIST HANGERS
STAIR TREADS TO BE
FABRICATED FROM 2x12s
SET AT A RISE OF 7 1/2" ±
AND A RUN OF 10" ±

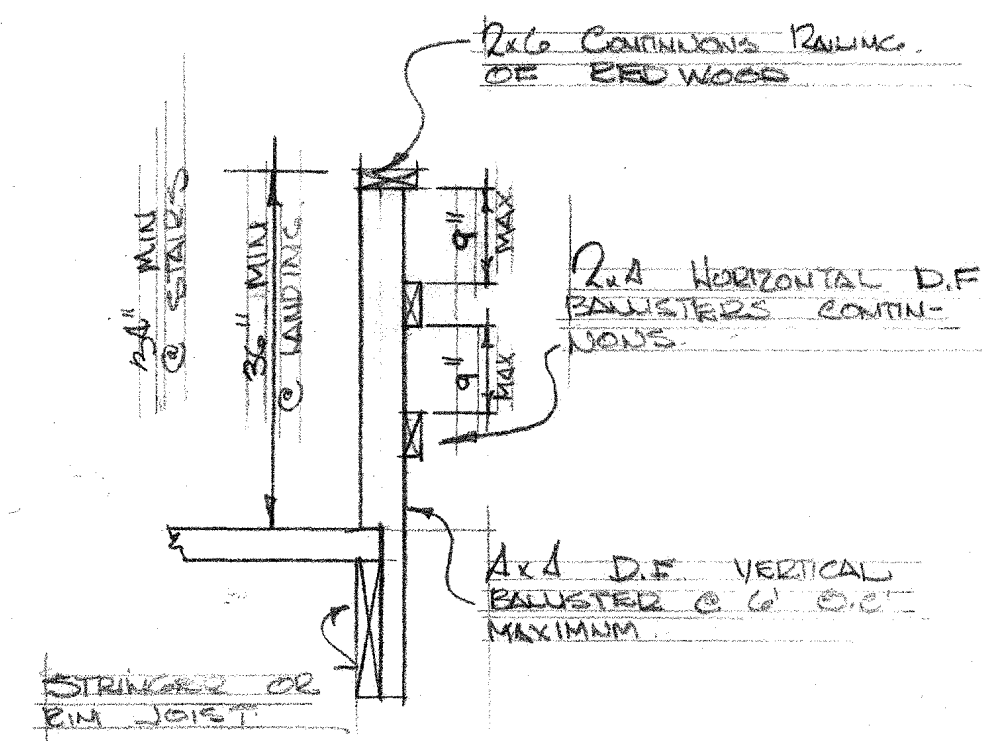

TYPICAL RAIL DETAIL
FOR LANDING & STAIRS
NO SCALE

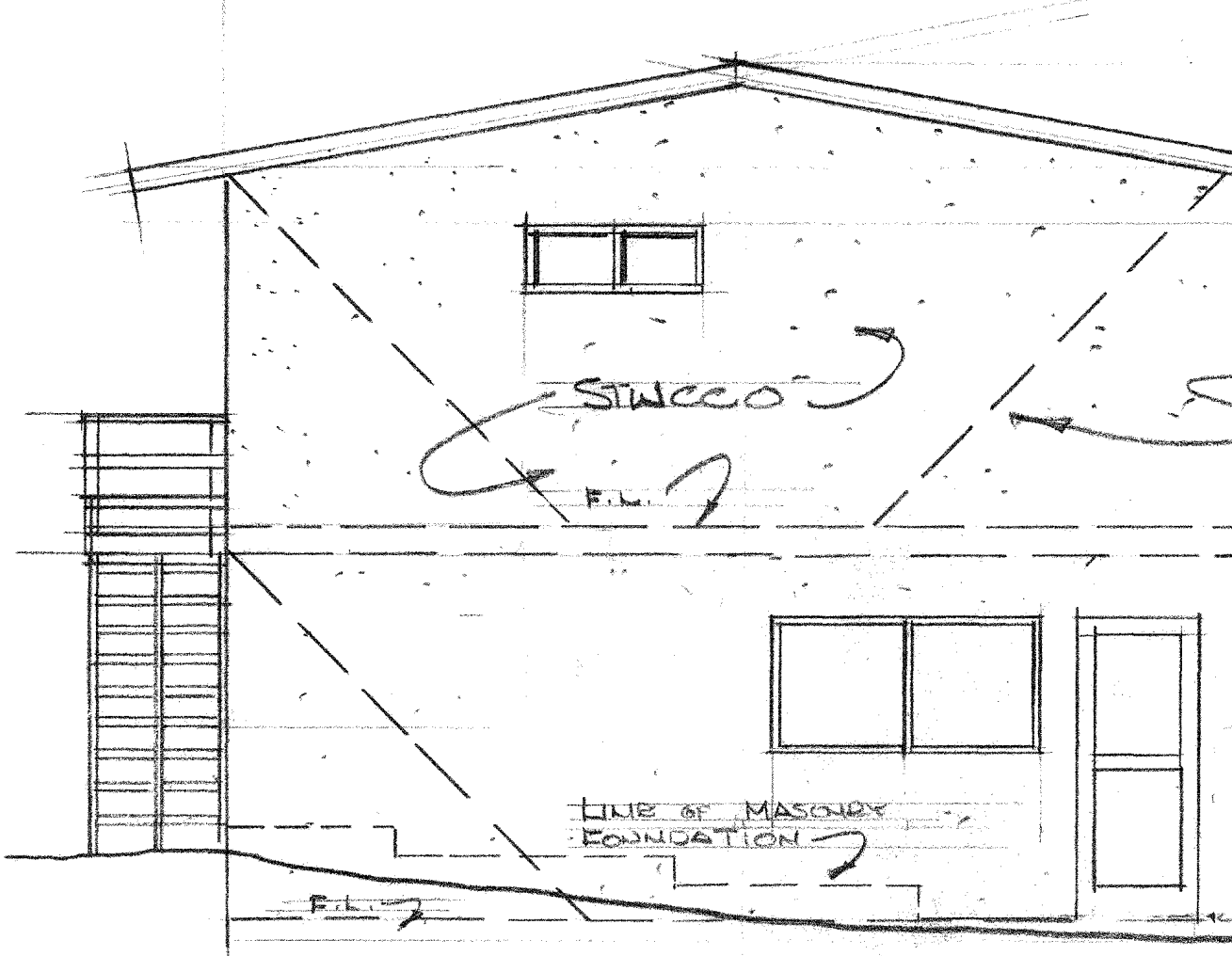

REAR

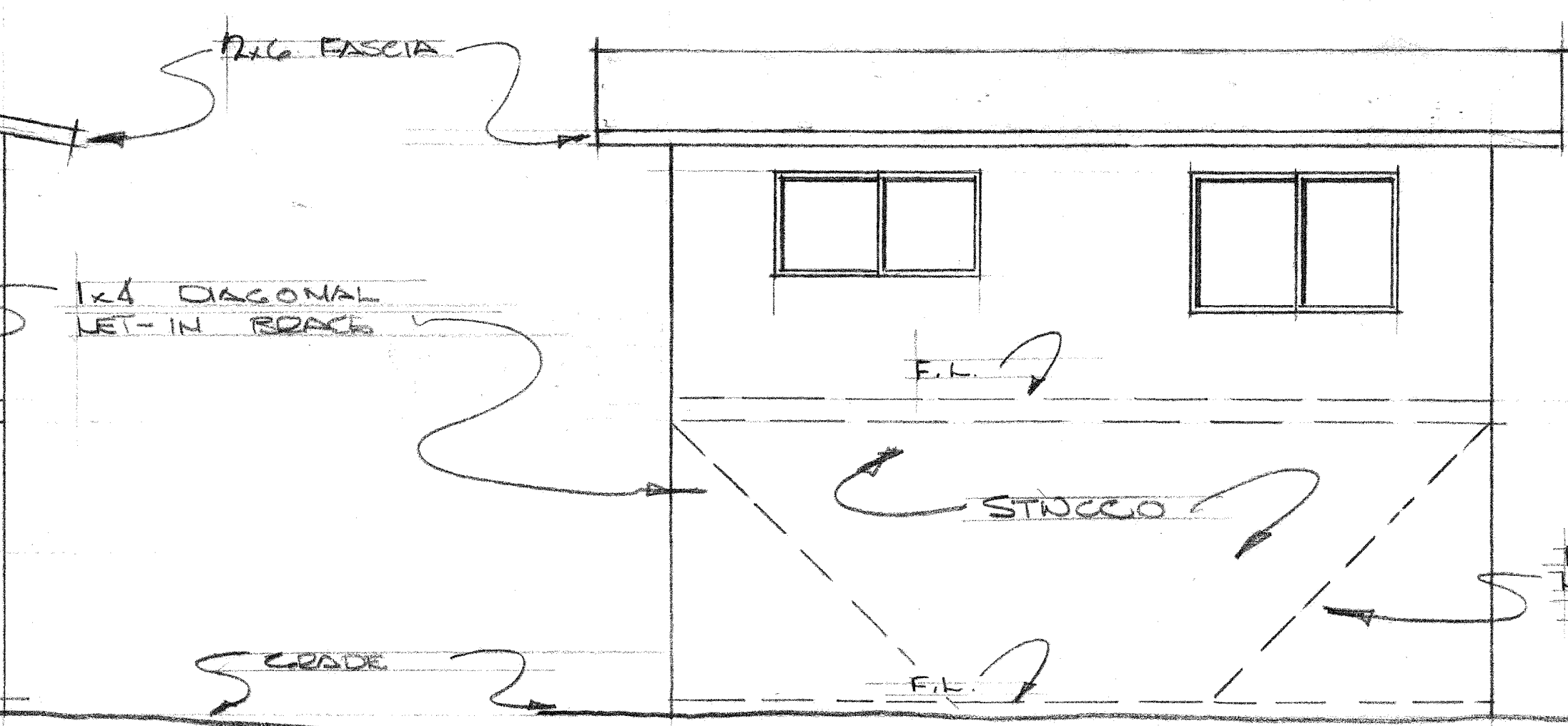

LEFT SIDE

EXTERIOR ELEVATIONS

1/4" = 1'-0"



STAFF REPORT CITY OF SOLANA BEACH

TO: Honorable Mayor and City Councilmembers
FROM: Gregory Wade, City Manager
MEETING DATE: April 27, 2022
ORIGINATING DEPT: City Clerk’s Office
SUBJECT: **Parks and Recreation Commission Appointment**

BACKGROUND:

All appointments to Citizen Commissions are conducted in accordance with Council Policy No. 5 - *Appointment of Citizens to Boards, Commissions, Committees, and Task Forces* (Attachment 1) - and all persons interested in serving on the City’s Citizen Commissions are required to “*complete and file ... a Citizen Interest Form (application),*” with the required references, and submit it to the City Clerk for formal application processing. The Application/Citizen Interest Form is available year-round at the City Clerk’s Office and on the City’s website. The Parks and Recreation Commission’s appointments are made by Council-at-large. A majority vote of the City Council is required for appointment.

This item is before the City Council to discuss and appoint a community member to serve on the Parks and Recreation Commission filling a vacancy that was not filled at the annual appointments in January.

DISCUSSION:

Noticing

On March 25, 2022, the City Clerk posted a Notice of Vacancy (Attachment 1), per Government Code 54974(a), with an application deadline of April 19, 2022, in an effort to fill the position and bring the Commission to full membership as quickly as possible. Recruitment notices were posted on the City’s Official bulletin board, the City’s website, and emailed out via e-blast notice.

Applicant Submittals

As of the preparation of this report, two (2) applications were received by the April 19th deadline and the Applicants are listed on Attachment 3. Per Council direction provided in January 2019, if applications are received after the deadline, they are not forwarded to Council for consideration.

Member Requirements

SBMC Section 2.72 outlines some of the duties of the Commission; however, there are other duties and assignments provided in relation to various opportunities and issues that occur

CITY COUNCIL ACTION: _____ _____

throughout the year. To carry out the Commission's work, SBMC Section 2.60.010 outlines the requirements of meeting attendance. As a legislative body, like the City Council, Citizen Commissions are required to fulfill a responsibility of participating in each meeting for all matters brought before the Commission. In addition, the Commission Handbook, provided to each appointed/re-appointed member, and posted online, provides various other requirements, regulations, guidelines, and procedures for Commission members.

Member Appointment

The official start date of the appointed Commission members takes effect once the official oath is administered by the City Clerk. The swear-in may take place before or at the first meeting of the Commission. The official oath is required in order to begin participating in Commission business.

FISCAL IMPACT: N/A

WORKPLAN: N/A

OPTIONS:

- Make an appointment to the Parks and Recreation Commission.
- Provide alternative direction.

DEPARTMENT RECOMMENDATION:

Staff recommends that the City Council consider the applications submitted and appoint one (1) member to the Parks and Recreation Commission nominated/appointed by *Council-at-large* for a term ending January 2024.

CITY MANAGER'S RECOMMENDATION:

Approve Department recommendation.



Gregory Wade, City Manager

Attachments:

1. Council Policy No. 5
2. Vacancy Notice
3. List of Applicants
4. Applications

CITY OF SOLANA BEACH	Policy No. 5
COUNCIL POLICY	Adopted: May 15, 1989 Revised: January 23, 2008 by Resolution 2008-23
GENERAL SUBJECT: Citizen Boards, Commissions & Committees	
SPECIFIC SUBJECT: Appointments of Citizens to Boards, Commissions, Committees and Task Forces.	

PURPOSE:

The purpose of this policy is to establish a consistent process and procedure for appointments to City sponsored Citizen Boards, Commissions, Committees and Task Forces.

POLICY STATEMENT:

Appointments to Citizen Boards, Commissions, Committees and Task Forces are made in accordance with the municipal code and/or specific guideline, as provided, to provide consistency.

POLICY PROCEDURES:

1. All private citizens interested in serving on any Board, Commission, Committee or Task Force or similar group must complete and file with the City Clerk a Citizen Interest Form (application) which may be obtained from the City Clerk's office.
2. Nominations
Councilmembers may nominate private citizens for appointment subject to ratification by a majority of the City Council. Such ratification shall take place at a regular City Council meeting and a duly docketed agenda item.
3. Appointment Protocol
 - a. Appointments will be made in accordance with municipal code requirements. For example, the municipal code may require that a Commission have five positions appointed by individual Councilmembers.
 - b. Appointments that are not outlined in the municipal code and are at-large appointment positions may be nominated by any Councilmember. In the event of multiple appointments, appointments may be divided among individual Councilmembers to share the appointment responsibilities. If the appointments are

shared, it will be for that one time and will not be construed as official individual appointments that would carry forward.

- c. The decision to proceed with an individual appointment alternative for at-large positions will be subject to majority vote of the City Council with such vote taking place at a regular City Council Meeting.

4. Appointments to Outside Agencies

When the City is asked by an outside agency to recommend a private citizen to serve on a Board, Commission, Committee or Task Force or similar group, such recommendation shall be made by the Council and approved by a majority vote of the City Council.



PUBLIC NOTICE

CITY'S CITIZEN COMMISSION POSITION OPENINGS

CITY OF SOLANA BEACH VOLUNTEERS SERVING ON BEHALF OF THE CITY COUNCIL

Applications are being accepted through **Tuesday, April 19, 2022, 5:30 p.m.**
City Council is scheduled to make appointments at the April 27, 2022 City Council Meeting.

PARKS & RECREATION: One Vacancy – term will expire January 2024

This Commission participates in reviewing certain matters regarding the City's parks, programs, and conducts certain City events. Commission members are responsible for planning, implementing, and working special events hosted by the Commission and/or the City.

Regular Meeting Schedule: 2nd Thursday of each month at 4:00 p.m.

Composition: 7 members who are all appointed by the Council At-large.

Position's Requirements: At least 18 yrs. old * Resident of the City.



Parks & Recreation Commission

[Citizen Interest Forms](#) (Applications) and additional information on the Commissions can be found on the City's website at www.cityofsolanabeach.org (Left tabs: City Government, City Clerk, Citizen Committees) OR at City Hall, 635 S. Highway 101, Solana Beach, (858) 720-2400. Please contact the City Clerk with any questions regarding the recruitment/appointment process.

❖ See the City's website for more meeting information, meeting agendas, members, and further information. ❖

**City of Solana Beach
Citizen Commission Member
Appointment by City Council**

**Application Status
Deadline April 19th 5:30 p.m.**

List of Applicants

PARKS & RECREATION COMMISSION

Applicant	Application Received
Sarah Hill	4-06-22
Dante Pride	4-19-22

APPLICATIONS

This Attachment is not posted online but is available by contacting the City Clerk's Office.



STAFF REPORT

CITY OF SOLANA BEACH

TO: Honorable Mayor and City Councilmembers
FROM: Gregory Wade, City Manager
MEETING DATE: April 27, 2022
ORIGINATING DEPT: City Manager's Department/City Attorney's Office
SUBJECT: **Introduce (1st Reading) Ordinance 523 – Amending Title 5 and Adding Chapter 5.07 to the Solana Beach Municipal Code to Regulate the Use, Sale and Distribution of Balloons Filled with Gas Lighter than Air**

BACKGROUND:

Lighter than air balloons are sold in several retail establishments in Solana Beach and pose multiple threats to animals, humans, and the environment. Plastic pollution from improperly disposed of and/or deteriorating balloons directly impacts the environment, wildlife, domesticated animals, and human health, and indirectly impacts the City's economy when it becomes beach litter. Lighter than air balloons are also a menace to utilities and fire departments, and when filled with helium, they threaten to deplete a precious, non-renewable resource important to science, industry and medicine. These will be discussed in more detail later in this report.

Residents and local environmental groups such as the Surfrider Foundation have expressed their desire to have the City consider adoption of an ordinance to regulate balloons filled with gas lighter than air. At the March 23, 2022 City Council (Council) meeting, Council directed Staff to bring back an ordinance for consideration.

This item is before Council to consider introducing Ordinance 523 (Attachment 1) amending Title 5 and adding chapter 5.07 to the Solana Beach Municipal Code to regulate the use, sale and distribution of balloons filled with gas lighter than air.

DISCUSSION

Plastic pollution is a significant environmental challenge and microplastics have been found in our drinking water, food, and the air we breathe. While plastic pollution reduction efforts have focused on single-use plastic bags, bottles, utensils and straws, balloons

CITY COUNCIL ACTION:

have been largely overlooked. Latex and Mylar are the two types of balloons in general use. Mylar balloons are petroleum-based and not biodegradable, and while latex does biodegrade, the latex balloons contain petroleum-based additives and are not 100% biodegradable. Researchers have observed that latex balloons deteriorate slowly and retain their elasticity even after floating in the ocean for 12 months. The release of both of these types of balloons results in additional plastic pollution which negatively impacts the safety of our citizens, wildlife, oceans, coastlines, and communities.

The Ocean Conservancy has determined that latex and Mylar balloons are the most common form of floating garbage within 200 miles of American shorelines. Beach litter surveys have shown that the number of balloons and balloon pieces found on beaches has tripled in the past 10 years. According to a National Oceanic and Atmospheric Administration (NOAA) Fisheries bulletin, every balloon released during well-meaning celebrations returns to earth as trash, with grave potential to injure or kill wildlife. Balloons can travel hundreds, sometimes thousands, of miles before landing, and those that land in the ocean resemble jellyfish, a favorite food of the threatened green sea turtle species residing off the coast of Solana Beach.

Once balloons are released, they eventually must come back down. When they do, balloons can sink thousands of meters to the ocean floor where they pollute deep-sea habitats. Once in the ocean, balloons become a hazard for marine wildlife. They are mistaken as food by federally-protected dolphins, whales, sea turtles and many other marine species. When ingested, balloons lead to a loss of nutrition, internal injury, starvation, and death. Another hazard are the balloon strings and ribbons that can wrap around marine organisms and entangle them, causing injury, illness, and suffocation.

Balloon debris has also negatively impact land animals and birds. According to the organization Balloons Blow...Don't Let Them Go, cows, dogs, sheep, tortoises, birds, and other terrestrial animals have all been injured or killed by balloons. Animals can become entangled in the balloon and its ribbon making them unable to move or eat. If ingested, the balloon will block the animal's digestive tract, preventing it from absorbing nutrients and causing the animal to slowly starve.

Balloon debris can even have a negative economic impact by contributing to dirty beaches, parks and communities which can create added costs to cities' budgets and drive away tourists. An article published by NOAA's Marine Debris Program states that balloon debris on shorelines contributes to dirty beaches, deterring tourists and residents from visiting and enjoying them.

Mylar balloons have also proven to be a constant menace to utilities and fire departments. Their metallic silvery coating serves as a conductor for electricity, which means they can short transformers and melt wires when they come near a high-voltage line. Mylar balloons pose a risk to our communities by sparking fires and interrupting electric service to essential facilities such as hospitals, schools, and traffic lights. According to SDG&E, over the past five years, mylar balloons have been identified as the cause of more than 500 power outages in the San Diego region's electrical system.

Professor Andrea Sella from University of College London explains that helium is a unique and precious non-renewable resource that is predicted to run out in 25 years due to human use. When it's gone, it is lost to us forever. This is of great concern because helium plays an important role in science, industry, and medicine. A few of the most important uses of helium are in MRI machines, the production of computer chips, and fiber optics. There have already been helium shortages in San Diego and nationwide, causing retailers to suspend the sale of helium filled balloons. It is therefore likely that the sale of helium balloons will continue to decline due to the decrease in helium availability and prioritization of its use for more essential activities such as medical treatment and research.

Glendale, Malibu, Hermosa Beach, and, most recently, Encinitas have adopted bans on lighter than air balloons. Many cities and some states across the nation are working to stop the sale and release of lighter than air balloons to reduce the harmful plastics that they leave behind in our oceans, parks and beaches. Plastics will continue to be part of our environment in the near-term, despite waste reduction efforts. Nevertheless, the most effective way to reduce balloon debris in the city's waterways and to protect our local environment is to prohibit the sale and intentional release of lighter than air-filled balloons due to their frequent release into the atmosphere and high likelihood of becoming coastal pollution.

In 1990, the California State Legislature passed Senate Bill (SB) 1990, enacting a statewide balloon law that regulates the sale and use of helium-filled foil balloons (metalized mylar). SB 1990 prohibits the sale or distribution of a balloon that is constructed of electrically conductive material and filled with a lighter than air gas (e.g., helium) without affixing an object of sufficient weight to the balloon to counter the lift capability. SB 1990 further requires affixing a specific warning statement on the balloon and affixing printed identification of the balloon's manufacturer.

While State legislation to regulate balloons has been in place for some time, a variety of emergent issues have been addressed locally by jurisdictions across California. In the development of the proposed Ordinance attached hereto, various local ordinances regulating balloons were evaluated, including the Cities of Hermosa Beach (2019), Glendale (2020), and Encinitas (2022). These ordinances generally address local concerns related to balloons, including specific prohibitions on the sale of metallic balloons (to prevent powerline entanglement and resultant fire danger and power disruption) or specific prohibitions on the intentional release of balloons.

The proposed Ordinance has been developed to address the critical local and regional concerns with balloons, including plastic pollution, marine debris, marine life impacts, land animal and bird impacts, negative economic impacts, and wildfire dangers. The proposed Ordinance includes the following key provisions:

- No Person, including, but not limited to, a balloon wholesaler, retailer, or third-party vendor, shall use, sell, or distribute any type of Balloon inflated with any Gas

Lighter Than Air within the City, either as a separate item or included in a packaged product set, including at any City Facility or City-Sponsored Event.

- No Person shall dispose of any Balloon inflated with any Gas Lighter Than Air within the City in any manner, including release outdoors into the air, other than in a trash container.
- This Section shall not apply to manned hot air balloons, or to balloons used in governmental or scientific research.

CEQA COMPLIANCE STATEMENT:

The proposed City Council action does not constitute a “project” under the definition set forth in California Environmental Quality Act (CEQA) Guidelines Section 15308 because it is an activity undertaken to assure the maintenance, restoration, enhancement and protection of the environment and pursuant to Section 15601(b)(3) because there is no possibility that the activity in question may have a significant effect on the environment.

FISCAL IMPACT:

There is no direct fiscal impact as a result of this item. However, implementation and enforcement of Ordinance 523, if adopted would be the responsibility of City Staff.

WORK PLAN:

N/A

OPTIONS:

- Introduce Ordinance 523 amending Title 5 and adding Chapter 5.07 to the Solana Beach Municipal Code to address the Use, Sale and Distribution of Balloons Filled with Gas Lighter than Air.
- Provide direction/feedback.

DEPARTMENT RECOMMENDATION:

Staff recommends the City Council introduce Ordinance 523 amending Title 5 and adding Chapter 5.07 to the Solana Beach Municipal Code to address the Use, Sale and Distribution of Balloons Filled with Gas Lighter than Air.

CITY MANAGER'S RECOMMENDATION:

Approve Department Recommendation



Gregory Wade, City Manager

Attachments:

1. Ordinance 523

ORDINANCE NO. 523

AN ORDINANCE OF THE CITY COUNCIL OF THE CITY OF SOLANA BEACH, CALIFORNIA, ADDING CHAPTER 5.07 TO THE SOLANA BEACH MUNICIPAL CODE PROHIBITING THE USE, SALE AND DISTRIBUTION OF BALLOONS FILLED WITH A GAS LIGHTER THAN AIR

WHEREAS, State law currently prohibits the outdoor release of any balloon constructed of electrically conductive material that is filled with a gas lighter than air as part of a public or civic event, promotional activity or product advertisement (California Penal Code Section 653.1 and Business and Professions Code Section 22942); and

WHEREAS, State law further requires that an object of sufficient weight be affixed to each Mylar balloon at the time of sale or distribution to counter the lift capability of the balloon, and also requires the manufacturer's name to be printed on the balloon, along with a permanent warning notice regarding the conductivity and danger of Mylar balloons (California Penal Code Section 653.1 and Business and Professions Code Section 22942); and

WHEREAS, the City of Solana Beach desires to implement additional measures to minimize the existence of balloons filled with a gas lighter than air within the City and mitigate the dangerous impacts from these balloons coming into contact with ocean life, animals and power lines; and

WHEREAS, balloons can be damaging to ecosystems and wildlife when released into the air or not disposed of properly, as they are not biodegradable; and

WHEREAS, the Ocean Conservancy lists balloons as the second most dangerous debris item since they are frequently mistaken as food by birds, mammals, and marine life. When balloons are ingested, they block the animals' digestive track, which leads to a loss of nutrition, internal injury, starvation, and death. Balloon ribbon is also hazardous because it can choke or entangle birds, mammals, and marine life in a manner that limits their mobility; and

WHEREAS, balloons are the most common form of floating garbage within 200 miles of American shorelines, and beach litter surveys have shown that the number of balloons and balloon pieces found on beaches has tripled in the past 10 years; and

WHEREAS, balloon debris on City beaches is prolific despite laws and regulations that prohibit littering, which contributes to dirty beaches, parks and communities, creates added costs to City budgets and discourages tourism; and

WHEREAS, balloons made of metalized or foil materials that conduct electricity, including

Mylar, also pose a safety hazard when released as they can cause power outages, explosions, downed power lines and damaged infrastructure when coming near or into direct contact with high-voltage power lines, resulting in costly repairs and/or hours of power outages affecting City residents and businesses; and

WHEREAS, over the past five years, Mylar balloons have been identified as the cause of more than 500 power outages in the San Diego region's electrical system; and

WHEREAS, the most effective way to reduce balloon debris in the City's waterways, decrease litter and pollution, and protect the environment, marine life, human health and the City's infrastructure, is to prohibit the use, sale and distribution of balloons filled with a gas lighter than air; and

NOW, THEREFORE, the City Council of the City of Solana Beach, California, does ordain as follows:

SECTION 1. All of the above recitals are true and correct.

SECTION 2. Chapter 5.07 of the Solana Beach Municipal Code is hereby added to read as follows: See "Exhibit A."

SECTION 3. The City Council finds that this Ordinance is exempt from the provisions of the California Environmental Quality Act ("CEQA") pursuant to Section 15308 of the CEQA Guidelines because it is an activity undertaken "to assure the maintenance, restoration, enhancement and protection of the environment" and pursuant to Section 15061(b)(3) because there is no possibility that the activity in question may have a significant effect on the environment.

SECTION 4. Severability. If any section, subsection, subdivision, paragraph, sentence, clause, phrase or portion of this Ordinance is, for any reason, held to be invalid or unconstitutional by any court of competent jurisdiction, such decision shall not affect the validity or effectiveness of the remaining portions of this Ordinance. The City Council hereby declares that it would have adopted this Ordinance and each section, subsection, subdivision, paragraph, sentence, clause, phrase and portion of this Ordinance irrespective of the fact that one or more, sections, subsections, subdivisions, paragraphs, sentences, clauses, phrases or portions thereof may be declared invalid or unconstitutional to this end, the provisions of this Ordinance are declared severable.

EFFECTIVE DATE: This Ordinance shall be effective thirty (30) days after its adoption. Within fifteen (15) days after its adoption, the City Clerk of the City of Solana Beach shall proceed with publication pursuant to the provisions of Government Code section 36933.

INTRODUCED AND FIRST READ this 27th day of April 2022, at a regular meeting of the City Council of the City of Solana Beach, California; AND

THEREAFTER ADOPTED at a regular meeting of the City Council of the City of Solana Beach, California, on the ___ day of _____, 2022, by the following vote:

- AYES: Councilmembers –
- NOES: Councilmembers –
- ABSENT: Councilmembers –
- ABSTAIN: Councilmembers –

LESA HEEBNER, Mayor

APPROVED AS TO FORM:

ATTEST:

JOHANNA N. CANLAS, City Attorney

ANGELA IVEY, City Clerk

CHAPTER 5.07

BALLOON ORDINANCE

5.07.010 Title.

This Chapter shall be known as the "Balloon Ordinance".

5.07.020 Purpose and Intent.

The purpose of this Chapter is to establish standards and procedures for environmental waste and litter reduction measures and promote environmentally sustainable practices throughout the City by prohibiting the use, sale and distribution of balloons filled with a gas lighter than air. In enacting this Chapter, it is the City's intent to further current prohibitions and regulations relating to balloons under State law and to protect the City's residents, businesses, animals, and infrastructure from damage caused by balloons. Nothing in this Chapter is intended to or shall be interpreted as conflicting with any federal or state law or regulation.

5.07.030 Definitions

For purposes of this Chapter only, the terms below have the following meaning:

"Balloon" means a flexible bag, including but not limited to, those made from rubber, latex, polychloroprene (neoprene), Mylar, or nylon fabric, that is designed to be inflated with a gas lighter than air, causing it to float, or designed to be filled with water. A balloon may be used for decorative, toy, or entertainment purposes. Balloons used for medical, industrial, or scientific purposes are not subject to the provisions of this ordinance.

"Gas Lighter Than Air" means a gas that has a lower density than normal atmospheric gases and rises above them as a result, including, but are not limited to, helium, hydrogen, methane, oxygen, and nitrogen.

"Person" means any person, business, corporation, or event organizer or promoter; public, nonprofit or private entity, agency or institution; or partnership, association or other organization or group, however organized.

5.07.040 Prohibition on the Use, Sale and Distribution of Balloons

A. No Person, including, but not limited to, a balloon wholesaler, retailer, or third-party vendor, shall use, sell, or distribute any type of Balloon inflated with any Gas Lighter Than Air within the City, either as a separate item or included in a packaged product set, including at any City Facility or City-Sponsored Event.

B. No Person shall dispose of any Balloon inflated with any Gas Lighter Than Air within the City in any manner, including release outdoors into the air, other than in a trash container.

C. This Section shall not apply to manned hot air balloons, or to balloons used in governmental or scientific research project.

5.07.050 Enforcement; Penalties.

A. Any violation of this Chapter shall be enforced through Chapters 1.16 and 1.18 of the Solana Beach Municipal Code.

B. Each violation of this Chapter shall be considered a separate offense.

C. The remedies and penalties provided in this Chapter are cumulative and not exclusive and nothing in this shall preclude the City from pursuing any other remedies. The City Attorney may seek legal, injunctive, or any other relief to enforce the provisions of this chapter and any regulations or administrative procedure developed pursuant hereto.



STAFF REPORT

CITY OF SOLANA BEACH

TO: Honorable Mayor and City Councilmembers
FROM: Gregory Wade, City Manager
MEETING DATE: April 27, 2022
ORIGINATING DEPT: City Manager's Department/City Attorney's Office
SUBJECT: **Adopt (2nd Reading) Ordinance 522 – Amending Chapter 7.20 and Adding Chapter 7.20.040 to the Solana Beach Municipal Code to Regulate Non-Serialized Untraceable Ghost Guns**

BACKGROUND:

To address the loophole in California resulting in the sale and use of unregulated, non-serialized and untraceable firearms, the City Council introduced Ordinance 522 on April 13, 2022.

These firearms are built from unregulated firearm parts, components and/or gun build kits known to be used to help create do-it-yourself "ghost guns". The ghost gun loophole allows people to buy and build firearms without passing a background check or complying with other laws that regulate the sale of firearms in California and the United States.

The action before the City Council is to consider adoption of Ordinance 522 amending Chapter 7.20 and adding 7.20.040 to the Solana Beach Municipal Code to regulate non-serialized untraceable ghost guns.

DISCUSSION:

Ghost guns have proven to be a loophole in the regulations designed to make safer the sale and use of firearms. Due to the nature of how ghost guns are created through do-it-yourself at-home kits, these firearms are not sold with unique serial numbers or identifying characteristics that would allow them to be traced. Further, because ghost guns are not regulated like other commercially manufactured firearms there are no background checks, waiting periods or age restrictions on their purchase. This loophole

CITY COUNCIL ACTION:

allows those who are underage to purchase ghost guns as well as criminals or others who would otherwise be barred from owning such weapons.

The City of Solana Beach has previously taken action to address the regulation of firearms and ghost guns in the City:

- On September 25, 2019, the City of Solana Beach adopted Ordinance 505, adding Section 7.20.030 to the Solana Beach Municipal Code requiring the safe residential storage of firearms in the City.
- In March 2020, the City of Solana Beach passed Resolution 2020-032 requesting that the 22nd District Agricultural Association to Prohibit the Sale of Unregulated Firearm Parts, Components and/or Gun Build Kits, known to be used to help create “ghost guns,” at the Del Mar Fairgrounds.
- On April 14, 2021, the City of Solana Beach passed Resolution 2021-046 expressing support for SB 264 (proposed state laws that would “prohibit a state or county officer or employee, or operator, lessee, or licensee of any state-owned or county-owned property, from contracting for, authorizing, or allowing the sale of any firearm, firearm precursor part, or ammunition on state or county property”) and AB 452 (requiring schools to notify parents about the safe storage of firearms).

This proposed ordinance has been drafted in consideration of State and Federal laws and strikes a balance to be consistent with these laws and to help address the frightening loophole created by the proliferation of ghost guns in our community. This ordinance will prohibit the possession, purchase and sale of non-serialized untraceable firearms in the City of Solana Beach and will help close the loophole that has allowed ghost guns to proliferate in our community.

CEQA COMPLIANCE STATEMENT:

The proposed City Council action does not constitute a “project” under the definition set forth in California Environmental Quality Act (CEQA) Guidelines Section 15378 because it will not have a potential to result in a direct or indirect physical change in the environment and is, therefore, not subject to CEQA.

FISCAL IMPACT:

There is no direct fiscal impact as a result of this item. However, implementation and enforcement of Ordinance 522, if adopted, would be the responsibility of City Staff and the San Diego Sheriff’s Department.

WORK PLAN:

Although not in the current FY 2021/22 Work Plan, the Council directed Staff at the March 23, 2022 City Council meeting to prioritize this ordinance for implementation prior to July 1, 2022.

OPTIONS:

- Adopt Ordinance 522 amending Chapter 7.20 and adding Chapter 7.20.040 to the Solana Beach Municipal Code to address non-serialized untraceable ghost guns.
- Do not adopt Ordinance 522 and provide direction/feedback.

DEPARTMENT RECOMMENDATION:

Staff recommends the City Council adopt Ordinance 522 amending Chapter 7.20 and adding Chapter 7.20.040 to the Solana Beach Municipal Code to address non-serialized untraceable ghost guns.

CITY MANAGER'S RECOMMENDATION:

Approve Department Recommendation



Gregory Wade, City Manager

Attachments:

1. Ordinance 522

ORDINANCE 522

AN ORDINANCE AMENDING CHAPTER 7.20 AND ADDING CHAPTER 7.20.040 OF THE SOLANA BEACH MUNICIPAL CODE RELATING TO NON-SERIALIZED, UNFINISHED FIREARM FRAMES OR RECEIVERS AND NON-SERIALIZED FIREARMS

WHEREAS, there is a massive loophole in California resulting in the sale and use of unregulated, non-serialized and untraceable firearms. These firearms are built from unregulated firearm parts, components and/or gun build kits known to be used to help create do-it-yourself “ghost guns;” and

WHEREAS, the ghost gun loophole allows people to buy and build firearms without passing a background check or complying with other laws that regulate the sale of firearms in California and the United States; and

WHEREAS, due to the nature of how ghost guns are created through do-it-yourself at-home kits, these firearms are not sold with unique serial numbers or identifying characteristics that would allow them to be traced; and

WHEREAS, because ghost guns are not regulated like other commercially manufactured firearms there are no background checks, waiting periods or age restrictions on their purchase. This loophole allows those who are underage to purchase ghost guns as well as criminals or others who would otherwise be barred from owning such weapons; and

WHEREAS, according to the Bureau of Alcohol, Tobacco, Firearms and Explosives, 30 percent of all guns seized in California in 2019 were ghost guns. The California Bureau of Firearms reported seizing 512% more ghost guns in 2019 than in 2018 and those numbers are on the rise; and

WHEREAS, on September 25, 2019, the City adopted Ordinance 505, adding Section 7.20.030 to the Solana Beach Municipal Code requiring the safe residential storage of firearms in the City; and

WHEREAS, in 2018 the California legislature effectuated a law that requires ghost gun builders to apply for a unique serial number from the Department of Justice within ten days of purchase (Cal. Penal Code 29180), but the requirement does not apply to sellers, leaving it legal to sell kits and parts without a serial number; and

WHEREAS, the California legislature passed a new state law that will require retailers to pass background checks and have a license, but the legislation does not go into effect until July 2022; and

WHEREAS, in March 2020, the City of Solana Beach passed Resolution 2020-032 requesting that the 22nd District Agricultural Association to Prohibit the Sale of Unregulated Firearm Parts, Components and/or Gun Build Kits, known to be used to help create ghost guns, at the Del Mar Fairgrounds; and

WHEREAS, this proposed ordinance has been drafted in consideration of State and Federal laws and remains consistent with these laws to help address the frightening loophole created by the proliferation of ghost guns in our community; and

WHEREAS, this proposed ordinance will prohibit the possession, purchase and sale of non-serialized untraceable firearms in the City of Solana Beach and will help close the loophole that has allowed ghost guns to proliferate in our community; and

WHEREAS, the City Council of the City of Solana Beach finds it is within its police power to implement and enforce the provisions of this Ordinance.

NOW, THEREFORE, the City Council of the City of Solana Beach, California, does ordain as follows:

Chapter 7.20 is hereby amended and Chapter 7.20.040 is hereby added to the City of Solana Beach municipal code, to read as follows:

7.20.040 Prohibition of Possession or Sale of Non-Serialized, Unfinished Firearm Frames or Receivers and Non-Serialized Firearms.

A. Purpose and Intent. It is the purpose and intent of this section that possession, purchase, sale, receipt, and transportation of non-serialized, unfinished frames and unfinished receivers, and non-serialized firearms within the City of Solana Beach be prohibited for the protection, health and welfare of the public, to further effective law enforcement, and to provide the City with reasonable measures to address the dangers to the community posed by non-serialized firearms, commonly known as “ghost guns.” This section is intended to be applied and interpreted consistent with state and federal law.

B. Definitions. The following definitions apply in this section:

1. “Federal Firearms Importer” has the same meaning as in 18 U.S.C. section 921(a)(9)(2019), as may be amended.
2. “Federal Firearms Manufacturer” has the same meaning as in 18 U.S.C. section 921(a)(10)(2019), as may be amended.
3. “Firearm” has the same meaning as in California Penal Code section 16520(a), as may be amended. As used in this section, firearm shall include a handgun, rifle, or shotgun.

4. "Frame" means the primary structural component of a firearm to which the fire control components are attached.
5. "Handgun" has the same meaning as in California Penal Code section 16640, as may be amended.
6. "Non-serialized Firearm" means a firearm that is not either imprinted with a serial number issued to that firearm by a Federal Firearms Importer or Federal Firearms Manufacturer in compliance with federal law or engraved or permanently affixed with a serial number provided by the California Department of Justice for that firearm.
7. "Person" has the same meaning as in SBMC 7.20.030.
8. "Receiver" means the primary structural component of a firearm to which the fire control components are attached.
9. "Rifle" has the same meaning as in California Penal Code section 17090, as may be amended.
10. "Shotgun" has the same meaning as in California Penal Code section 17190, as may be amended.
11. "Unfinished Frame" means a piece of any material that does not constitute the completed frame of a firearm, but that has been shaped or formed in any way for the purpose of becoming the frame of a firearm, and which may be made into a functional frame of a firearm through milling, drilling, or other means.
12. "Unfinished Receiver" means a piece of any material that does not constitute the completed receiver of a firearm, but that has been shaped or formed in any way for the purpose of becoming the receiver of a firearm, and which may be made into a functional receiver of a firearm through milling, drilling, or other means.

C. Prohibition. It is unlawful for any Person to:

1. Possess, purchase, transport, or receive an unfinished frame or unfinished receiver, unless the unfinished frame or unfinished receiver is imprinted with a serial number issued to that unfinished frame or unfinished receiver by a Federal Firearms Importer or Federal Firearms Manufacturer, or engraved or permanently affixed with a serial number provided by the California Department of Justice for that unfinished frame or unfinished receiver.
 - a. This subsection shall not apply to a Federal Firearms Importer or Federal Firearms Manufacturer.

- b. This subsection shall not apply to an employee or sworn peace officer of a local, state, or federal law enforcement agency if the employee or sworn peace officer is acting within the scope of official duties.
 - c. This subsection shall not apply to a common carrier licensed or regulated under state or federal law or an authorized agent of a common carrier when acting in the course and scope of duties incident to the receipt, processing, transportation, or delivery of property.
 2. Sell, offer to sell, transfer, or offer to transfer an unfinished frame or unfinished receiver, unless the unfinished frame or unfinished receiver is imprinted with a serial number issued to that unfinished frame or unfinished receiver by a Federal Firearms Importer or Federal Firearms Manufacturer, or engraved or permanently affixed with a serial number provided by the California Department of Justice for that unfinished frame or unfinished receiver.
 3. Possess, purchase, transport, or receive a non-serialized firearm.
 - a. This subsection shall not apply to an employee or sworn peace officer of a local, state, or federal law enforcement agency if the employee or sworn peace officer is acting within the scope of official duties.
 - b. This subsection shall not apply to a common carrier licensed or regulated under state or federal law or an authorized agent of a common carrier when acting in the course and scope of duties incident to the receipt, processing, transportation, or delivery of property.
 - c. This subsection shall not apply to a *non-serialized firearm* if any of the following conditions apply:
 - i. The non-serialized firearm has been rendered permanently inoperable.
 - ii. The non-serialized firearm is an antique firearm as defined in California Penal Code section 16170, as may be amended.
 - iii. The non-serialized firearm was manufactured or assembled prior to 1968.
 - iv. The non-serialized firearm has been determined to be a collector's item pursuant to 26 U.S.C. Ch. 53, including section 5845 (2019), as may be amended, or a curio or relic pursuant to 18 U.S.C. Ch. 44, including section 921(a) (2019), as may be amended, and 27 C. F. R. section 478.11 (2019), as may be amended.

- v. The non-serialized firearm has been entered into the centralized registry set forth in California Penal Code section 11106, as may be amended, prior to July 1, 2018, as being owned by a specific individual or entity if that firearm has assigned to it a distinguishing number or mark of identification.
 - d. It shall be an affirmative defense to this subsection that the person is in compliance with California Penal Code section 29180, as may be amended.
4. Sell, offer to sell, transfer, or offer to transfer a non-serialized firearm. This subsection shall not apply to a non-serialized firearm if any of the following conditions apply:
- a. The non-serialized firearm has been rendered permanently inoperable.
 - b. The non-serialized firearm is an antique firearm as defined in California Penal Code section 16170, as may be amended.
 - c. The non-serialized firearm was manufactured or assembled prior to 1968.
 - d. The non-serialized firearm has been determined to be a collector's item pursuant to 26 U.S.C. Ch. 53, including section 5845 (2019), as may be amended, or a curio or relic pursuant to 18 U.S.C. Ch. 44, including section 921(a) (2019), as may be amended, and 27 C. F. R. section 478.11 (2019), as may be amended.

EFFECTIVE DATE: This Ordinance shall be effective thirty (30) days after its adoption. Within fifteen (15) days after its adoption, the City Clerk of the City of Solana Beach shall proceed with publication pursuant to the provisions of Government Code section 36933.

INTRODUCED AND FIRST READ this 13th day of April 2022, at a regular meeting of the City Council of the City of Solana Beach, California; AND

THEREAFTER ADOPTED at a regular meeting of the City Council of the City of Solana Beach, California, on the ___ day of _____, 2022, by the following vote:

AYES: Councilmembers –
NOES: Councilmembers –
ABSENT: Councilmembers –
ABSTAIN: Councilmembers –

LESA HEEBNER, Mayor

APPROVED AS TO FORM:

ATTEST:

JOHANNA N. CANLAS, City Attorney

ANGELA IVEY, City Clerk



STAFF REPORT

CITY OF SOLANA BEACH

TO: Honorable Mayor and City Councilmembers
FROM: Gregory Wade, City Manager
MEETING DATE: April 27, 2022
ORIGINATING DEPT: Angela Ivey, City Clerk
SUBJECT: **Introduce (1st Reading) Ordinance 516 Adding Section 2.24.085, Electronic Filing of Campaign Statements, to the Solana Beach Municipal Code**

BACKGROUND:

The Political Reform Act of the State of California requires elected officers, political candidates and committees to file campaign statements by specified deadlines disclosing contributions received and expenditures made. These documents are public and help voters to be fully informed. The City Clerk is the local filing officer/official for the City of Solana Beach and is responsible for receiving Fair Political Practices Commission (FPPC) campaign disclosure filings, reviewing, storing, and making them accessible to the public. The City Clerk acts as the Filing *Official* for GC87200 filers and the Filing *Officer* for the City's designated filers.

On January 1, 2013, Assembly Bill 2452 went into effect, adding California Government Code section 84615 (Attachment 2), which allows local government agencies to require online or electronic filing for an elected officer, candidate, committee, or other person who is required to file statements, reports, or other documents under the Political Reform Act.

On January 1, 2021, Assembly Bill 2151 went into effect, adding California Government Code section 84616 (Attachment 3), which requires a local government agency to post on its internet website, within 72 hours of the applicable filing deadline, a copy of any specified statement, report, or other document filed with that agency in paper format, with applicable redactions for online postings. This bill requires that the statement, report, or other document be made available for four years from the date of the election associated with the filing.

Beginning with the 2021 filings due in 2022, the City Clerk's office began utilizing electronic filings for Statements of Economic Interests, Form 700.

COUNCIL ACTION:

The item is before the City Council to introduce Ordinance 516 (Attachment 1) to implement electronic online filing as required by AB 2151.

DISCUSSION:

Since Government Code section 84615 went into effect, many local government agencies throughout California have chosen to enact paperless filing as a courtesy to their campaign filers, to increase staff efficiency, and to help reduce the use of paper. In addition, with adoption of Government Code section 84616 requiring a local government agency to post any paper filings on the City's website within 72 hours of the applicable filing deadline, it is more efficient to require and provide electronic filings.

The City Clerk's office accepts FPPC filings of two major categories of economic disclosure documents: (1) campaign statements (commonly known as Form 460's) disclosing contributions received and expenditures made by local candidates, local committees, and ballot measure campaigns and (2) statements of economic interests (commonly known as Form 700s) from designated public officials and employees, both with specified deadlines. In most instances, these documents are filed with the City Clerk as the filing officer/official. If the documents are not filed in a timely fashion, penalties are imposed.

Advantages:

There are many advantages to requiring electronic filing of disclosure documents. All FPPC forms are public records. By shifting to an electronic system, the public benefits with direct 24-hour access to campaign statements on the City's website, providing greater transparency to the voters. The system is also beneficial to filers by providing multiple prompts to ensure timely filing, storing previous statements for user ease, information entered into the system by filers will carry over from one filing to the next reducing errors and the need to file amendments, and permitting a single filing for multiple offices. Further, implementation of a paperless system increases efficiency to the City and Staff with time savings and improves sustainability by reducing overall consumption, not only of paper, but also of ink, plastic packaging, and reduces transportation emissions tied to delivery and disposal of products.

Current Filings:

The City Clerk's office began utilizing Granicus (Southtech) software for electronic filings of Statements of Economic Interests (Form 700) with 2021 filings due in 2022. However, currently campaign finance disclosure filings are accepted on paper which requires significant Staff time to redact appropriate information and post to the City's website.

Authorize Online Filings for Campaign Statements:

For the City of Solana Beach to accept electronically filed campaign statements, the City Council must adopt an ordinance permitting the use of an online filing system as an option for filing and designating the filings received electronically by the City Clerk's Office as

the filings of record for the City. In addition, the system must operate securely and effectively. The ordinance incorporates the safeguards required by State law, including:

- The electronic filing system shall not place an undue burden on filers and include procedures for filers to comply with the requirement that they sign statements and reports under penalty of perjury; and
- The system shall ensure the integrity of the data transmitted and include safeguards against efforts to tamper with, manipulate, alter, or subvert the data; and
- The local filing officer shall make all data available on the internet in an easily understood format that provides the greatest public access; and
- The agency shall enable filers to complete and submit electronic filings free of charge.

Adoption of the proposed ordinance will only apply to those filers that meet a threshold of \$200 (current limit) or more for expending or receiving campaign funds. This threshold is more stringent than the Political Reform Act (the "Act"), which recognizes campaigns that spend or raise \$2,000 (current limit) or more as "Controlled Committees." Under the Act, these types of committees are obligated to file detailed campaign finance disclosure statements, also known as Form 460s. For those smaller campaigns that do not meet the threshold of \$200 (current City limit), they may continue to file paper versions of the Form 470 disclosure forms (although such filers may choose to file electronically for convenience).

Vendor and Software:

The City Clerk contacted the two vendors approved by the Secretary of State when considering one for the Form 700 online filings. Granicus, LLC. (Southtech) was selected since it provided the best economic terms, user functionality, and is the current eDisclosure host provider for the FPPC. It should be noted that the system is able to accommodate the online filing of several types of required forms by the FPPC, including Form 410 Statement of Organization, Form 460 Recipient Committee Campaign Statement Management, Form 461 Independent Expenditure Committee and Major Donor Committee Campaign Statement, Form 470 Officeholder/Candidate Campaign Statement - Short Form, Form 496 24-Hour Independent Expenditure Report, Form 497 24-Hour Contribution Report, and Form 501 Candidate Intention Statement.

The Granicus (Southtech) system is a web-based, vendor-hosted application that utilizes "industry best practices" for securing data, using the same data encryption for online filings that is used by banks for online banking. The Granicus (Southtech) system stores and backs up data, creating the essential safety measures and redundancy that will allow for recovery of information in the event of an emergency or disaster. The City's data will be retained for the required minimum 10-year period on the online filing system. For those reports/data that are subject to permanent retention, they will be archived in a secure format after the 10-year period.

In addition, the Granicus (Southtech) system provides reports of which filings are due and tracks which candidates/committees have filed campaign statements as they are received. The filer enters information online to complete a filing. In subsequent years, the filer can simply update information that changed since the prior filing, thus saving the filer from going through time-consuming resubmission efforts. Committee information, contribution amounts, and summary page balances are automatically transferred and aggregated in future reports. The electronic filing system automatically calculates dollar totals on all schedules and transmits those totals to the summary page. The electronic filing system is available to filers 24/7 and can be accessed virtually anywhere the filer has access to the internet. The Granicus (Southtech) system also includes a Public Access module. This allows the public and staff to search the database and retrieve electronic document images of the disclosure documents for viewing and printing.

Transition Timeline:

If this mandated electronic filing of campaign disclosure statements is approved, the requirement to electronically file campaign disclosure statements would become effective June 10, 2022, which is thirty (30) days following the proposed adoption of the ordinance after its second reading scheduled for the May 11, 2022 City Council Meeting. To facilitate the full transition to electronic filing, the City Clerk's Office will continue to provide detailed instructions and training.

The goal is to provide sufficient time for the City Clerk's Office to conduct implementation measures and training prior to the beginning of the nomination period, July 18, 2022, for the 2022 elections.

CEQA COMPLIANCE STATEMENT:

Not a project as defined by CEQA.

FISCAL IMPACT:

The fee for the Granicus (Southtech) system is based on an annual subscription cost determined by population. The cost for the City of Solana Beach will be \$1,000 annually which will be incorporated into the City Clerk's budget. As noted above, the electronic filing system is free of charge to filers and free to the public for viewing purposes.

OPTIONS:

- Approve Staff recommendation.
- Approve Staff recommendation with alternative amendments / modifications.
- Deny Staff recommendation.

DEPARTMENT RECOMMENDATION:

Introduce Ordinance 516, related to electronic campaign statements, adding Section 2.24.085 Electronic Filing of Campaign Statements to the Solana Beach Municipal Code.

CITY MANAGER'S RECOMMENDATION:

Approve Department Recommendation.



Gregory Wade, City Manager

Attachments:

1. Ordinance 516

ORDINANCE 516

AN ORDINANCE OF THE CITY COUNCIL OF THE CITY OF SOLANA BEACH, CALIFORNIA, ADDING SECTION 2.24.085, ELECTRONIC FILING OF CAMPAIGN STATEMENTS, TO THE SOLANA BEACH MUNICIPAL CODE

WHEREAS, the Political Reform Act of the State of California requires elected officers, political candidates, and committees to file campaign statements by specified deadlines disclosing contributions received and expenditures made. These documents are public and help voters to be fully informed. The City Clerk is the local filing officer/official for the City of Solana Beach and is responsible for receiving Fair Political Practices Commission (FPPC) campaign disclosure filings, reviewing, storing, and making them accessible to the public; and,

WHEREAS, on January 1, 2013, Assembly Bill 2452 went into effect, adding California Government Code section 84615, which allows local government agencies to require online or electronic filing for an elected officer, candidate, committee, or other person who is required to file statements, reports, or other documents under the Political Reform Act; and

WHEREAS, on January 1, 2021, Assembly Bill 2151 went into effect, adding California Government Code section 84616, which requires a local government agency to post on its internet website, within 72 hours of the applicable filing deadline, a copy of any specified statement, report, or other document filed with that agency in paper format. This bill requires that the statement, report, or other document be made available for four years from the date of the election associated with the filing; and

WHEREAS, the City intends to enter into an agreement with a vendor approved by the California Secretary of State, to provide an online electronic filing system ("System") for campaign disclosure statements; and

WHEREAS, the System will operate securely and effectively and will not unduly burden filers. Specifically: (1) the System will ensure the integrity of the data and includes safeguards against efforts to tamper with, manipulate, alter or subvert the data; (2) the System will only accept a filing in the standardized record format developed by the Secretary of State and compatible with the Secretary of State's system for receiving an online or electronic filing; and (3) the System will be available free of charge to filers and to the public for viewing filings; and

WHEREAS, the City will operate the electronic filing system in compliance with the requirements of California Government Code Section 84615 and any other applicable laws; and

WHEREAS, the City desires to amend Title 2, Administration & Personnel, Chapter 2.24, Elections, to add Section 2.24.085 entitled “Electronic Filing of Campaign Statements” to the Solana Beach Municipal Code; and

NOW THEREFORE, the City Council of the City of Solana Beach does ordain as follows:

Section 1. Purpose and Authority.

The purpose of this section is to require the filing of Campaign Disclosure Statements by elected officials, candidates, and committees electronically. The City Council enacts this Ordinance in accordance with the authority granted to cities by State law. This Ordinance is intended to supplement, and not conflict with, the Political Reform Act.

Section 2. Findings.

Pursuant to California Government Code Section 85615, the City of Solana Beach hereby finds that the online or electronic filing system required by this section will operate securely and effectively and will not unduly burden filers. Said System promotes the use of electronic filing of campaign forms required by the State of California to provide for a streamlined, paperless, and secure system to meet the demand for digital and transparent systems.

Section 3. Section 2.24.085

Section 2.24.085 is hereby added to Title 2 (Administration and Personnel), Chapter 2.24, Elections to read as follows:

**“Section 2.24.085
Electronic Filing of Campaign Statements**

- A. Any elected officer, candidate, committee, or other person required to file statements, reports, or other documents required by Chapter 4 of the Political Reform Act 1 of 3 (commencing with Section 84100 of the Government Code) and Solana Beach Municipal Code 2.24. These procedures shall ensure that the online filing system complies with the requirements set forth in Section 84615 of the California Government Code. Elected officers, candidates, or committees required to file statements must file such Statements using the City’s online filing system, unless exempt from the requirement to file online pursuant to Government Code Section 84615, as may be amended from time to time.
- B. In any instance in which an original statement, report or other document must be filed with the California Secretary of State and a copy of that statement, report or other document is required to be filed with City Clerk, the filer may, but is not required to, file the Clerk’s copy electronically.

- C. The online filing system shall ensure the integrity of the data transmitted and shall include safeguards against efforts to tamper with, manipulate, alter, or subvert the data.
- D. The online filing system shall only accept a filing in the standardized record format that is developed by the California Secretary of State pursuant to Section 84602(a)(2) of the California Government Code and that is compatible with the Secretary of State's system for receiving an online or electronic filing.
- E. The online filing system shall include a procedure for filers to comply with the requirement that they sign statements and reports under penalty of perjury pursuant to Section 81004 of the Government Code.
- F. The City Clerk's office shall maintain for a period of at least 10 years commencing from the date filed, or other period required by law, a secured, official version of each online or electronic statement, report, form, or other document on the City Clerk's online filing system, which shall serve as the official version of that record for purpose of audits and any other legal purpose. Data that has been maintained for at least 10 years may then be archived in a secure format.
- G. If the City Clerk's electronic system is not capable of accepting a particular type of statement, report or other document, the City Clerk Administrator may allow the elected officer, candidate, committee, or other person to file that document with the City Clerk in an alternative method, if it otherwise complies with all other requirements of this Section.
- H. Procedures for Utilizing Online Filing.
 - 1. Electronic filing is mandatory unless the officer, candidate, or committee is exempt as described in Section 2-30.10(c)(1) or California Government Code 84615.
 - 2. Any elected officer, candidate, or committee who has electronically filed a statement using the City Clerk's online filing system is not required to file a copy of that document in paper format with the City Clerk.
 - 3. The City Clerk or the online filing system shall issue an electronic confirmation that notifies the filer that the Statement was received, the notification shall include the date and the time that the Statement was received and the method by which the filer may view and print the data received by the City Clerk. The date of filing for a Statement filed online shall be the day that it is received by the City Clerk.
 - 4. If the City Clerk's online filing system is not capable of accepting a Statement due to technical difficulties, an elected officer, candidate, or committee shall file that Statement in paper format with the City Clerk.
 - 5. The online filing system shall enable electronic filers to complete and submit filings free of charge.
- I. Except as otherwise provided in, or inconsistent with, this Chapter or other provisions of local law, the provisions of the California Political Reform Act relating

to local elections including any subsequent amendments are hereby incorporated as part of this Section.”

Section 2. Severability

The provisions of this chapter are declared to be severable and if any provision, sentence, clause, section or part of this chapter is held illegal, invalid, unconstitutional or inapplicable to any person or circumstances, such illegality, invalidity or unconstitutionality or inapplicability shall not affect or impair any of the remaining provisions, sentences, clauses, sections or parts of this chapter or their application to persons and circumstances.”

EFFECTIVE DATE: This Ordinance shall be effective thirty (30) days after its adoption. Within fifteen (15) days after its adoption, the City Clerk of the City of Solana Beach shall proceed with publication pursuant to the provisions of California Government Code §36933.

INTRODUCED AND FIRST READ at a meeting of the City Council of the City of Solana Beach, California, on the 27th day of April, 2022; and

THEREAFTER ADOPTED at a regular meeting of the City Council of the City of Solana Beach, California, on the ___ day of _____, 2022, by the following vote:

AYES: Councilmembers –
NOES: Councilmembers –
ABSTAIN: Councilmembers –
ABSENT: Councilmembers –

LESA HEEBNER, Mayor

APPROVED AS TO FORM:

ATTEST:

JOHANNA N. CANLAS, City Attorney

ANGELA IVEY, City Clerk