

# CITY OF SOLANA BEACH

SOLANA BEACH CITY COUNCIL, SUCCESSOR AGENCY TO THE REDEVELOPMENT AGENCY,  
PUBLIC FINANCING AUTHORITY, & HOUSING AUTHORITY



## AGENDA

### Joint REGULAR Meeting

Wednesday, February 14, 2018 \* 6:00 P. M.

City Hall / Council Chambers, 635 S. Highway 101, Solana Beach, California

- City Council meetings are video recorded and archived as a permanent record. The video recording captures the complete proceedings of the meeting and is available for viewing on the City's website.
- Posted Reports & Supplemental Docs contain records up to the cut off time prior to meetings for processing new submittals. Complete records containing meeting handouts, PowerPoints, etc. can be obtained through a [Records Request](#).

#### PUBLIC MEETING ACCESS

The Regular Meetings of the City Council are scheduled for the 2nd and 4th Wednesdays and are broadcast live on Cox Communications-Channel 19, Time Warner-Channel 24, and AT&T U-verse Channel 99. The video taping of meetings are maintained as a permanent record and contain a detailed account of the proceedings. Council meeting tapings are archived and available for viewing on the City's website.

#### AGENDA MATERIALS

A full City Council agenda packet including relative supporting documentation is available at City Hall, the Solana Beach Branch Library (157 Stevens Ave.), La Colonia Community Ctr., and online [www.cityofsolanabeach.org](http://www.cityofsolanabeach.org). Agendas are posted at least 72 hours prior to regular meetings and at least 24 hours prior to special meetings. Writings and documents regarding an agenda of an open session meeting, received after the official posting, and distributed to the Council for consideration, will be made available for public viewing at the same time. In addition, items received at least 1 hour 30 minutes prior to the meeting time will be uploaded online with the courtesy agenda posting. Materials submitted for consideration should be forwarded to the City Clerk's department 858-720-2400. The designated location for viewing public documents is the City Clerk's office at City Hall during normal business hours.

#### SPEAKERS

Please submit a speaker slip to the City Clerk prior to the meeting, or the announcement of the Section/Item, to provide public comment. Allotted times for speaking are outlined on the speaker's slip for each agenda section: Oral Communications, Consent, Public Hearings and Staff Reports.

#### AMERICAN DISABILITIES ACT TITLE 2

In compliance with the Americans with Disabilities Act of 1990, persons with a disability may request an agenda in appropriate alternative formats as required by Section 202. Any person with a disability who requires a modification or accommodation in order to participate in a meeting should direct such request to the City Clerk's office (858) 720-2400 at least 72 hours prior to the meeting.

As a courtesy to all meeting attendees, please set cellular phones and pagers to silent mode and engage in conversations outside the Council Chambers.

#### CITY COUNCILMEMBERS

**Ginger Marshall, Mayor**

**David A. Zito, Deputy Mayor**

**Jewel Edson, Councilmember**

**Judy Hegenauer, Councilmember**

**Mike Nichols, Councilmember**

Gregory Wade  
City Manager

Johanna Canlas  
City Attorney

Angela Ivey  
City Clerk

**SPEAKERS:**

Please submit your speaker slip to the City Clerk prior to the meeting or the announcement of the Item. Allotted times for speaking are outlined on the speaker's slip for Oral Communications, Consent, Public Hearings and Staff Reports.

**READING OF ORDINANCES AND RESOLUTIONS:**

Pursuant to Solana Beach Municipal Code Section 2.04.460, at the time of introduction or adoption of an ordinance or adoption of a resolution, the same shall not be read in full unless after the reading of the title, further reading is requested by a member of the Council. If any Councilmember so requests, the ordinance or resolution shall be read in full. In the absence of such a request, this section shall constitute a waiver by the council of such reading.

**CALL TO ORDER AND ROLL CALL:**

**CLOSED SESSION REPORT:** (when applicable)

**FLAG SALUTE:**

**APPROVAL OF AGENDA:**

**PROCLAMATIONS/CERTIFICATES:** *Ceremonial*

*None at the posting of this agenda*

**PRESENTATIONS:** Ceremonial items that do not contain in-depth discussion and no action/direction.

1. Solana Beach Civic and Historical Society

**ORAL COMMUNICATIONS:**

This portion of the agenda provides an opportunity for members of the public to address the City Council on items relating to City business and not appearing on today's agenda by submitting a speaker slip (located on the back table) to the City Clerk. Comments relating to items on this evening's agenda are taken at the time the items are heard. Pursuant to the Brown Act, no action shall be taken by the City Council on public comment items. Council may refer items to the City Manager for placement on a future agenda. The maximum time allotted for each presentation is THREE MINUTES (SBMC 2.04.190). Please be aware of the timer light on the Council Dais.

**COUNCIL COMMUNITY ANNOUNCEMENTS / COMMENTARY:**

*An opportunity for City Council to make brief announcements or report on their activities. These items are not agendaized for official City business with no action or substantive discussion.*

**A. CONSENT CALENDAR:** (Action Items) (A.1. - A.4.)

Items listed on the Consent Calendar are to be acted in a single action of the City Council unless pulled for discussion. Any member of the public may address the City Council on an item of concern by submitting to the City Clerk a speaker slip (located on the back table) before the Consent Calendar is addressed. Those items removed from the Consent Calendar by a member of the Council will be trailed to the end of the agenda, while Consent Calendar items removed by the public will be discussed immediately after approval of the Consent Calendar.

#### **A.1. Minutes of the City Council.**

Recommendation: That the City Council

1. Approve the Minutes of the City Council Meetings held December 13, 2017.

##### [Item A.1. Report \(click here\)](#)

*Posted Reports & Supplemental Docs contain records up to the cut off time, prior to the start of the meeting, for processing new submittals. The final official record containing handouts, PowerPoints, etc. can be obtained through a Records Request to the City Clerk's Office.*

#### **A.2. Register Of Demands. (File 0300-30)**

Recommendation: That the City Council

1. Ratify the list of demands for January 6, 2018 through January 26, 2018.

##### [Item A.2. Report \(click here\)](#)

*Posted Reports & Supplemental Docs contain records up to the cut off time, prior to the start of the meeting, for processing new submittals. The final official record containing handouts, PowerPoints, etc. can be obtained through a Records Request to the City Clerk's Office.*

#### **A.3. General Fund Adopted Budget for Fiscal Year 2017-2018 Changes. (File 0330-30)**

Recommendation: That the City Council

1. Receive the report listing changes made to the Fiscal Year 2017-2018 General Fund Adopted Budget.

##### [Item A.3. Report \(click here\)](#)

*Posted Reports & Supplemental Docs contain records up to the cut off time, prior to the start of the meeting, for processing new submittals. The final official record containing handouts, PowerPoints, etc. can be obtained through a Records Request to the City Clerk's Office.*

#### **A.4. Streetlight Preventative Maintenance and Repair Services. (File 0820-35)**

Recommendation: That the City Council

1. Adopt **Resolution 2018-011**:
  - a. Authorizing the City Manager to execute Amendment No. 2 to the Professional Services Agreement with Siemens Industry, Inc. for streetlight preventative maintenance and repair services for FY 2017/18 to increase the compensation by \$37,095 for a contract total amount not to exceed \$69,429.
  - b. Authorizing an appropriation of \$33,745 from the Streetlight District Reserves for partial funding of the amendment to the Agreement with Siemens Industry, Inc.
  - c. Authorizing the City Treasurer to amend the FY 2017/18 Adopted Budget accordingly.

##### [Item A.4. Report \(click here\)](#)

*Posted Reports & Supplemental Docs contain records up to the cut off time, prior to the start of the meeting, for processing new submittals. The final official record containing handouts, PowerPoints, etc. can be obtained through a Records Request to the City Clerk's Office.*

**NOTE: The City Council shall not begin a new agenda item after 10:30 p.m. unless approved by a unanimous vote of all members present. (SBMC 2.04.070)**

**B. PUBLIC HEARINGS:** (B.1. – B.3.)

This portion of the agenda provides citizens an opportunity to express their views on a specific issue as required by law after proper noticing by submitting a speaker slip (located on the back table) to the City Clerk. After considering all of the evidence, including written materials and oral testimony, the City Council must make a decision supported by findings and the findings must be supported by substantial evidence in the record. An applicant or designees for a private development/business project, for which the public hearing is being held, is allotted a total of fifteen minutes to speak, as per SBMC 2.04.210. A portion of the fifteen minutes may be saved to respond to those who speak in opposition. All other speakers have three minutes each. Please be aware of the timer light on the Council Dais.

**B.1. Public Hearing: 201 Lomas Santa Fe, Applicant: AT&T Mobility, Case 17-17-15.**  
(File 0610-60)

Recommendation: The proposed project meets the minimum zoning requirements under the SBMC, may be found to be consistent with the General Plan and may be found, as conditioned, to meet the discretionary findings required as discussed in this report to approve a DRP. Therefore, Staff recommends that the City Council:

1. Conduct the Public Hearing: Open the Public Hearing, Report Council Disclosures, Receive Public Testimony, and Close the Public Hearing.
2. Find the project exempt from the California Environmental Quality Act pursuant to Section 15301 of the State CEQA Guidelines; and
3. Adopt **Resolution 2017-167** conditionally approving a CUP/DRP/SDP for a new WCF and associated equipment located on the roof of an existing commercial office building at 201 Lomas Santa Fe, Solana Beach.

**[Item B.1. Report \(click here\)](#)**

*Posted Reports & Supplemental Docs contain records up to the cut off time, prior to the start of the meeting, for processing new submittals. The final official record containing handouts, PowerPoints, etc. can be obtained through a Records Request to the City Clerk's Office.*



**B.2. Public Hearing: 439 S. Cedros, Applicant: 439 Cedros, LLC, Case 17-17-29.**  
(File 0600-40)

Recommendation: The proposed project meets the minimum zoning requirements under the SBMC, may be found to be consistent with the General Plan and may be found, as conditioned, to meet the discretionary findings required as discussed in this report to approve a DRP. Therefore, Staff recommends that the City Council:

1. Conduct the Public Hearing: Open the Public Hearing, Report Council Disclosures, Receive Public Testimony, and Close the Public Hearing.
2. Find the project exempt from the California Environmental Quality Act pursuant to Section 15303 of the State CEQA Guidelines; and
3. If the City Council makes the requisite findings and approves the project, adopt **Resolution 2018-014** conditionally approving a DRP to convert 1,291 square feet of an existing commercial building to a café, construct a new 540 square foot outdoor seating area and a new parking lot to provide 16 new parking spaces at 439 S. Cedros Avenue.

[Item B.2. Report \(click here\)](#)

*Posted Reports & Supplemental Docs contain records up to the cut off time, prior to the start of the meeting, for processing new submittals. The final official record containing handouts, PowerPoints, etc. can be obtained through a Records Request to the City Clerk's Office.*

**B.3. Public Hearing: 601 W. Circle, Applicants: Harris, Case 17-17-13.** (File 0600-40)

Recommendation: The proposed project meets the minimum objective requirements under the LUP, SBMC, is consistent with the General Plan and may be found, as conditioned, to meet the discretionary findings required as discussed in this report to approve a DRP. Therefore, Staff recommends that the City Council:

1. Conduct the Public Hearing: Open the Public Hearing, Report Council Disclosures, Receive Public Testimony, and Close the Public Hearing.
2. Find the project exempt from the California Environmental Quality Act pursuant to Section 15303 of the State CEQA Guidelines; and
3. If the City Council makes the requisite findings and approves the project, adopt **Resolution 2018-013** conditionally approving to convert the existing garage to living area, add a covered patio and remodel the interior of an existing single-story residence on property at 601 W. Circle Drive.

[Item B.3. Report \(click here\)](#)

*Posted Reports & Supplemental Docs contain records up to the cut off time, prior to the start of the meeting, for processing new submittals. The final official record containing handouts, PowerPoints, etc. can be obtained through a Records Request to the City Clerk's Office.*

**C. STAFF REPORTS:** (C.1.)

*Submit speaker slips to the City Clerk.*

**C.1. Mid-Year Budget Adjustments for Fiscal Year 2017-2018.** (File 0330-30)

Recommendation: That the City Council

1. Adopt **Resolution 2018-015** revising appropriations in the Fiscal Year 2017/18 Budget.

**[Item C.1. Report \(click here\)](#)**

*Posted Reports & Supplemental Docs contain records up to the cut off time, prior to the start of the meeting, for processing new submittals. The final official record containing handouts, PowerPoints, etc. can be obtained through a Records Request to the City Clerk's Office.*

**WORK PLAN COMMENTS:**

*Adopted June 14, 2017*

**COMPENSATION & REIMBURSEMENT DISCLOSURE:**

GC: Article 2.3. Compensation: 53232.3. (a) Reimbursable expenses shall include, but not be limited to, meals, lodging, and travel. 53232.3 (d) Members of a legislative body shall provide brief reports on meetings attended at the expense of the local agency at the next regular meeting of the legislative body.

**COUNCIL COMMITTEE REPORTS:**

**Regional Committees: (outside agencies, appointed by this Council)**

- a. City Selection Committee (meets twice a year) – Nichols (Edson, alternate).
- b. County Service Area 17 – Marshall (Nichols, alternate).
- c. Escondido Creek Watershed Authority – Marshall/Staff (no alternate).
- d. League of Ca. Cities' San Diego County Executive Committee – Nichols (Edson, alternate) and any subcommittees.
- e. League of Ca. Cities' Local Legislative Committee – Nichols (Edson, alternate)
- f. League of Ca. Cities' Coastal Cities Issues Group (CCIG) – Nichols (Edson, alternate)
- g. North County Dispatch JPA – Marshall (Edson, alternate).
- h. North County Transit District – Edson (Nichols, alternate)
- i. Regional Solid Waste Association (RSWA) – Nichols (Hegenauer, alternate).
- j. SANDAG – Zito (Primary), Edson (1<sup>st</sup> alternate), Nichols (2<sup>nd</sup> alternate) and any subcommittees.
- k. SANDAG Shoreline Preservation Committee – Zito (Hegenauer, alternate).
- l. San Dieguito River Valley JPA – Hegenauer (Nichols, alternate).
- m. San Elijo JPA – Marshall, Zito (City Manager, alternate).
- n. 22<sup>nd</sup> Agricultural District Association Community Relations Committee – Marshall, Edson.

**Standing Committees: (All Primary Members) (Permanent Committees)**

- a. Business Liaison Committee – Zito, Edson.
- b. Solana Beach-Del Mar Relations Committee – Nichols, Zito
- c. Highway 101 / Cedros Ave. Development Committee – Edson, Nichols.
- d. Fire Dept. Management Governance & Organizational Evaluation – Edson, Hegenauer
- e. I-5 Construction Committee – Zito, Edson.
- f. Parks and Recreation Committee – Nichols, Zito
- g. Public Arts Committee – Marshall, Hegenauer.
- h. School Relations Committee – Nichols, Hegenauer.

**ADJOURN:**

---

**Next Regularly Scheduled Meeting is February 28, 2018**  
*Always refer the City's website Event Calendar for updated schedule or contact City Hall.*  
[www.cityofsolanabeach.org](http://www.cityofsolanabeach.org) 858-720-2425

---

**AFFIDAVIT OF POSTING**

STATE OF CALIFORNIA }  
COUNTY OF SAN DIEGO } §  
CITY OF SOLANA BEACH }

I, Angela Ivey, City Clerk of the City of Solana Beach, do hereby certify that this Agenda for the February 14, 2018 Council Meeting was called by City Council, Successor Agency to the Redevelopment Agency, Public Financing Authority, and the Housing Authority of the City of Solana Beach, California, was provided and posted on February 7, 2018 at 6:15 p.m. on the City Bulletin Board at the entrance to the City Council Chambers. Said meeting is held at 6:00 p.m., February 14, 2018, in the Council Chambers, at City Hall, 635 S. Highway 101, Solana Beach, California.

Angela Ivey, City Clerk  
City of Solana Beach, CA

---

**UPCOMING CITIZEN CITY COMMISSION AND COMMITTEE MEETINGS:**

*Regularly Scheduled, or Special Meetings that have been announced, as of this Agenda Posting. Dates, times, locations are all subject to change. See the City's Commission's website or the City's Events Calendar for updates.*

**Budget & Finance Commission**

Thursday, February 15, 2018, 5:30 p.m. (City Hall)

**Climate Action Commission**

Wednesday, February 21, 2018, 5:30 p.m. (City Hall)

**Parks & Recreation Commission**

Thursday, March 8, 2018, 4:00 p.m. (Fletcher Cove Community Center)

**Public Arts Commission**

Tuesday, February 27, 2018, 5:30 p.m. (City Hall)

**View Assessment Commission**

Tuesday, February 20, 2018, 6:00 p.m. (Council Chambers)

# CITY OF SOLANA BEACH

SOLANA BEACH CITY COUNCIL, SUCCESSOR AGENCY TO THE REDEVELOPMENT AGENCY,  
PUBLIC FINANCING AUTHORITY, & HOUSING AUTHORITY

## MINUTES

Joint Meeting - Closed Session

Wednesday, December 13, 2017 \* 5:15 p.m.

City Hall / Council Chambers, 635 S. Highway 101, Solana Beach, California



### CITY COUNCILMEMBERS

Mike Nichols, Mayor

Ginger Marshall, Deputy Mayor

David A. Zito, Councilmember

Jewel Edson, Councilmember

Judy Hegenauer, Councilmember

Gregory Wade  
City Manager

Johanna Canlas  
City Attorney

Angela Ivey  
City Clerk

### CALL TO ORDER AND ROLL CALL:

Mayor Nichols called the meeting to order at 5:15 p.m.

Present: Mike Nichols, Ginger Marshall, David A. Zito, Jewel Edson, Judy Hegenauer  
Absent: None  
Also Present: Gregory Wade, City Manager  
Johanna Canlas, City Attorney

### PUBLIC COMMENT ON CLOSED SESSION ITEMS (ONLY):

*Report to Council Chambers and submit speaker slips to the City Clerk  
before the meeting recesses to closed session.*

### CLOSED SESSION:

#### 1. CONFERENCE WITH LEGAL COUNSEL – ANTICIPATED LITIGATION

Pursuant to Government Code Section 54956.9(d)(2)  
One (1) Potential case.

**ACTION:** No reportable action.

### ADJOURN:

Mayor Nichols adjourned the meeting at 5:45 p.m.

Angela Ivey, City Clerk

Approved: \_\_\_\_\_

**CITY OF SOLANA BEACH**  
SOLANA BEACH CITY COUNCIL, SUCCESSOR AGENCY TO THE REDEVELOPMENT AGENCY,  
PUBLIC FINANCING AUTHORITY, & HOUSING AUTHORITY



## MINUTES

### Joint REGULAR Meeting

**Wednesday, December 13, 2017 \* 6:00 P. M.**

City Hall / Council Chambers, 635 S. Highway 101, Solana Beach, California

- City Council meetings are video recorded and archived as a permanent record. The video recording captures the complete proceedings of the meeting and is available for viewing on the City's website.
- Posted Reports & Supplemental Docs contain records up to the cut off time prior to meetings for processing new submittals. Complete records containing meeting handouts, PowerPoints, etc. can be obtained through a Records Request.

#### CITY COUNCILMEMBERS

**Ginger Marshall, Mayor**

**David A. Zito, Deputy Mayor**

**Jewel Edson, Councilmember**

**Judy Hegenauer, Councilmember**

**Mike Nichols, Councilmember**

Gregory Wade  
City Manager

Johanna Canlas  
City Attorney

Angela Ivey  
City Clerk

---

#### **CALL TO ORDER AND ROLL CALL:**

Councilmember Nichols called the meeting to order at 6:00 p.m.

Present: Mike Nichols, Ginger Marshall, David A. Zito, Jewel Edson, Judy Hegenauer

Absent: None

Also Present: Greg Wade, City Manager

Johanna Canlas, City Attorney  
Angela Ivey, City Clerk,  
Mo Sammak, City Engineer/Public Works Dir.  
Marie Berkuti, Finance Manager  
Bill Chopyk, Community Development Dir.  
Dan King, Assistant City Manager

#### **CLOSED SESSION REPORT:** (when applicable)

Johanna Canlas, City Attorney, stated that there was no reportable action.

#### **FLAG SALUTE:**

#### **APPROVAL OF AGENDA:**

**Motion:** Moved by Councilmember Zito and second by Councilmember Edson to approve.  
**Approved 5/0.** Motion carried unanimously.

#### **C. STAFF REPORTS:** (C.1.)

*Submit speaker slips to the City Clerk.*

**C.1. Annual Mayoral Rotation: Mayor / Deputy Mayor Appointments.** (File 0430-20)

Recommendation: That the City Council

1. Nominate and Appoint the 2018 Mayor and Deputy Mayor for a term of December 13, 2017 to December 12, 2018.

a. Mayor calls for a nomination of a new Mayor. Call for the vote.

**Motion:** Moved by Councilmember Edson and second by Councilmember Hegenauer to appoint Ginger Marshall as Mayor. **Approved 5/0.** Motion carried unanimously.

b. Newly appointed Mayor calls for nomination of a Deputy Mayor. Call for the vote.

**Motion:** Moved by Councilmember Edson and second by Mayor Marshall to appoint David Zito as Deputy Mayor. **Approved 5/0.** Motion carried unanimously.

Item C.1. Report (click here)

*Posted Reports & Supplemental Docs contain records up to the cut off time, prior to the start of the meeting, for processing new submittals. The final official record containing handouts, PowerPoints, etc. can be obtained through a Records Request to the City Clerk's Office.*

Mayor Marshall recessed the meeting at 6:12 p.m. for a break and reconvened at 6:24 p.m.

**ORAL COMMUNICATIONS: NONE**

This portion of the agenda provides an opportunity for members of the public to address the City Council on items relating to City business and not appearing on today's agenda by submitting a speaker slip (located on the back table) to the City Clerk. Comments relating to items on this evening's agenda are taken at the time the items are heard. Pursuant to the Brown Act, no action shall be taken by the City Council on public comment items. Council may refer items to the City Manager for placement on a future agenda. The maximum time allotted for each presentation is THREE MINUTES (SBMC 2.04.190). Please be aware of the timer light on the Council Dais.

**COUNCIL COMMUNITY ANNOUNCEMENTS / COMMENTARY:**

*An opportunity for City Council to make brief announcements or report on their activities. These items are not agendized for official City business with no action or substantive discussion.*

**A. CONSENT CALENDAR: (Action Items) (A.1. - A.5.)**

Items listed on the Consent Calendar are to be acted in a single action of the City Council unless pulled for discussion. Any member of the public may address the City Council on an item of concern by submitting to the City Clerk a speaker slip (located on the back table) before the Consent Calendar is addressed. Those items removed from the Consent Calendar by a member of the Council will be trailed to the end of the agenda, while Consent Calendar items removed by the public will be discussed immediately after approval of the Consent Calendar.

**A.1. Register Of Demands.** (File 0300-30)

Recommendation: That the City Council

1. Ratify the list of demands for October 28, 2017 through November 24, 2017.

Item A.1. Report (click here)

*Posted Reports & Supplemental Docs contain records up to the cut off time, prior to the start of the meeting, for processing new submittals. The final official record containing handouts, PowerPoints, etc. can be obtained through a Records Request to the City Clerk's Office.*

**Motion:** Moved by Councilmember Edson and second by Mayor Marshall to approve. **Approved 5/0.** Motion carried unanimously.

**A.2. General Fund Adopted Budget for Fiscal Year 2017-2018 Changes.** (File 0330-30)

Recommendation: That the City Council

1. Receive the report listing changes made to the Fiscal Year 2017-2018 General Fund Adopted Budget.

Item A.2. Report (click here)

*Posted Reports & Supplemental Docs contain records up to the cut off time, prior to the start of the meeting, for processing new submittals. The final official record containing handouts, PowerPoints, etc. can be obtained through a Records Request to the City Clerk's Office.*

**Motion:** Moved by Councilmember Edson and second by Mayor Marshall to approve.  
**Approved 5/0.** Motion carried unanimously.

**A.3. Underground Utility District along Nardo, Granados, Rios, Corto, Lirio, Palmitas and Via de Vista.** (File 1010-90)

Recommendation: That the City Council

1. Adopt **Resolution 2017-158**, approving the payment to SDG&E of \$53,710 from the City's share of CPUC Rule 20A funds in seed money to cover the design costs for the preparation of preliminary plans and preliminary cost estimate by SDG&E for the Nardo/Granados/Rios Underground Utility District that would include properties along Nardo Avenue, South Granados Avenue, South Rios Avenue, Corto Street, Lirio Street, Palmitas Street and Via de Vista.

Item A.3. Report (click here)

*Posted Reports & Supplemental Docs contain records up to the cut off time, prior to the start of the meeting, for processing new submittals. The final official record containing handouts, PowerPoints, etc. can be obtained through a Records Request to the City Clerk's Office.*

**Motion:** Moved by Councilmember Edson and second by Mayor Marshall to approve.  
**Approved 5/0.** Motion carried unanimously.

**A.4. Residential Solid Waste Management Agreement.** (File 1030-15)

Recommendation: That the City Council

1. Adopt **Resolution 2017-170** authorizing the assignment of the residential solid waste management Franchise Agreement from Coast Waste Management to EDCO Waste and Recycling Services; and
2. Authorize the City Manager to negotiate a new comprehensive Franchise Agreement with EDCO for consideration by Council at a future Council meeting.

Item A.4. Report (click here)

*Posted Reports & Supplemental Docs contain records up to the cut off time, prior to the start of the meeting, for processing new submittals. The final official record containing handouts, PowerPoints, etc. can be obtained through a Records Request to the City Clerk's Office.*

**Motion:** Moved by Councilmember Edson and second by Mayor Marshall to approve.  
**Approved 5/0.** Motion carried unanimously.

*This item was pulled by a public speaker.*

**A.5. Community Grant Program Awards.** (File 0330-25)

Recommendation: That the City Council

1. Adopt **Resolution 2017-171** authorizing the funding for all community grant applicants for financial assistance under the Fiscal Year 2017-18 Community Grant Program.

Item A.5. Report (click here)

Greg Wade, City Manager, introduced the item.

Rebecca Hill stated that she was with the American Association of University Women and coordinated the Tech Trak science and math week long camp held at San Diego State University for seventh grade girls who showed interest in stem careers at a cost of approximately \$900 per person.

Councilmember Zito and Ms. Hill discussed that the organization would accept the condition that funding from the City would be focused to economically disadvantaged children.

Deanna Wolf thanked Council for the award to Casa de Amistad, that funding had supported 20 recent graduating seniors with 10 of them submitting U.C. applications to UC schools for next fall, and applicants' interests included computer programming, nursing, engineering, and kinesiology.

**Motion:** Moved by Deputy Mayor Zito and second by Councilmember Edson to approve the allocation, condition the American Association of University Women to fund economically disadvantaged children, and to fund the additional \$3,000 from reserves. **Approved 5/0.** Motion carried unanimously.

American Association of University Women	\$5,000
Assistance League Rancho San Dieguito	\$3,000
Boys and Girls Club of San Dieguito	\$5,000
Casa De Amistad	\$5,000
Community Resource Center	\$5,000
La Colonia de Eden Gardens	\$5,000
North Coast Repertory Theatre	\$5,000
North County Immigration & Citizenship Center	\$5,000
Reality Changers	\$5,000
Solana Beach Civic and Historical Society	\$5,000
<b>Total</b>	<b>\$48,000</b>

### **C. STAFF REPORTS:** (C.2.)

*Submit speaker slips to the City Clerk.*

#### **C.2. Comprehensive Annual Financial Report (CAFR) for Fiscal Year 2016-17.** (File 0310-22)

Recommendation: That the City Council

1. Accept and file the City of Solana Beach Comprehensive Annual Financial Report (CAFR) for the fiscal year July 1, 2016 – June 30, 2017.
2. Accept and file the Communication of Internal Control related matters identified in an Audit letter.
3. Accept and file the Independent Accountants' Report on Agreed-Upon Procedures Applied to Appropriations Limit Worksheets letter.



4. Accept and file the Auditor's Communication with those charged with Governance letter.
5. Accept and file the Report on Compliance for the Housing Successor.

**Item C.2. Report (click here)**

*Posted Reports & Supplemental Docs contain records up to the cut off time, prior to the start of the meeting, for processing new submittals. The final official record containing handouts, PowerPoints, etc. can be obtained through a Records Request to the City Clerk's Office.*

Greg Wade, City Manager, introduced the item

Marie Berkuti, Finance Manager, presented a PowerPoint (on file)

Brian Gruber, LSL, presented a PowerPoint (on file).

Deputy Mayor Zito and Mr. Gruber discussed appropriate contingency reserves that the minimum standard guideline was 15%, the City was at 17% which was average, that some cities do establish higher contingencies, that it was a balance of current and anticipated expenditures, that there had been no significant issues, and suggestions had been made and enacted and some were an ongoing process.

**Motion:** Moved by Deputy Mayor Zito and second by Councilmember Edson to approve.  
**Approved 5/0.** Motion carried unanimously.

**B. PUBLIC HEARINGS:** (B.1. – B.4.)

This portion of the agenda provides citizens an opportunity to express their views on a specific issue as required by law after proper noticing by submitting a speaker slip (located on the back table) to the City Clerk. After considering all of the evidence, including written materials and oral testimony, the City Council must make a decision supported by findings and the findings must be supported by substantial evidence in the record. An applicant or designees for a private development/business project, for which the public hearing is being held, is allotted a total of fifteen minutes to speak, as per SBMC 2.04.210. A portion of the fifteen minutes may be saved to respond to those who speak in opposition. All other speakers have three minutes each. Please be aware of the timer light on the Council Dais.

**B.1. Public Hearing: 201 Lomas Santa Fe, Applicant: AT&T Mobility, Case 17-17-15.**  
(File 0610-60)

Recommendation: That the City Council

1. Conduct the Public Hearing: Open the Public Hearing, Report Council disclosures, Receive public testimony, Close the Public Hearing.
2. Find the project exempt from the California Environmental Quality Act pursuant to Section 15301 of the State CEQA Guidelines; and
3. Adopt **Resolution 2017-167** conditionally approving a Conditional Use Permit (CUP), Development Review Permit (DRP) and Structure Development Permit (SDP) for a new Wireless Cell Facility (WCF) and associated equipment located on the roof of an existing commercial office building at 201 Lomas Santa Fe, Solana Beach.

[Item B.1. Report \(click here\)](#)

[Item B.1. Supplemental Documents \(12-13-17 updated 4:00pm\)](#)

*Posted Reports & Supplemental Docs contain records up to the cut off time, prior to the start of the meeting, for processing new submittals. The final official record containing handouts, PowerPoints, etc. can be obtained through a Records Request to the City Clerk's Office.*

Corey Andrews, Principal Planner, presented a PowerPoint (on file).

Mayor Marshall opened the public hearing.

Council disclosures.

Tim Henion, AT&T representative, said the height of the structure was the same as determined by the survey they had conducted on the project, and that the land survey called out the top of the atrium feature.

Council and applicant representative discussed that this location was the applicant's first preferred location and that Council Policy's guideline's fourth preferred location, relocating to a different location on the building would be more obtrusive or lose the beneficial coverage, that the applicant requested the fire station location but it was rejected and that a medical building on Lomas Santa Fe was approached but they were not interested, and this location was finally preferred because it was the best coverage running up Lomas Santa Fe and with a single sight rather than multiple sites, that the Presbyterian Church site was reviewed but would still require an additional site to achieve the required coverage.

Discussion continued regarding achieving a less intrusive location with dual locations on the building to not block the view shed, that the architectural railing would be impacted, and that the AM/PM store location structure considered would have hung off of the building.

Johanna Canlas, City Attorney, stated that there was a tolling agreement that would expire January 12, 2018, that Council appeared to be struggling with making the finding that this was the least obtrusive of all proposals, and that the applicant may consider providing a different location or different illustration on the existing proposed location.

**Motion:** Moved by Councilmember Nichols and second by Councilmember Edson to close the public hearing. **Approved 5/0.** Motion carried unanimously.

**Motion:** Moved by Councilmember Nichols and second by Deputy Mayor Zito to re-open the public hearing. **Approved 5/0.** Motion carried unanimously.

Council and Applicant discussion regarding continuing the public hearing.

**Motion:** Moved by Councilmember Nichols and second by Deputy Mayor Zito to continue the public hearing to a date certain of January 10, 2018. **Approved 5/0.** Motion carried unanimously.

**B.2. Public Hearing: 225 Pacific Avenue, Applicants: Mark and Felicia Barr, Case 17-12-21.** (File 0600-40)

Recommendation: That the City Council

1. Conduct the Public Hearing: Open the public hearing, Report Council disclosures, Receive public testimony, Close the public hearing.
2. Find the project exempt from the California Environmental Quality Act pursuant to Section 15303 of the State CEQA Guidelines; and
3. If the Council can make the required findings, adopt **Resolution 2017-138**, approving the request for a Development Review Permit (DRP) and Structure Development Permit (SDP) modification for the proposed single-family residence and attached garage at 225 Pacific Avenue.

Item B.2. Report (click here)

*Posted Reports & Supplemental Docs contain records up to the cut off time, prior to the start of the meeting, for processing new submittals. The final official record containing handouts, PowerPoints, etc. can be obtained through a Records Request to the City Clerk's Office.*

Greg Wade, City Manager, introduced the item.

Corey Andrews, Principal Planner, presented a PowerPoint (on file).

Mayor Marshall opened the public hearing.

Council disclosures.

James Chinn, applicant's representative, said that they had attempted to obtain a Coastal Commission permit 4 months ago and had just received a signed approved permit, that they ran out of time to use the City's permit based on Coastal Commission's delay, and asked for approval.

**Motion:** Moved by Deputy Mayor Zito and second by Mayor Marshall to close the public hearing. **Approved 5/0.** Motion carried unanimously.

**Motion:** Moved by Deputy Mayor Zito and second by Mayor Marshall to approve. **Approved 5/0.** Motion carried unanimously.

**B.3. Public Hearing: 781 E. Solana Circle, Applicant: Corsetti, Case 17-17-25.** (File 0600-40)

Recommendation: That the City Council

The proposed project meets the minimum objective requirements under the Park Del Mar Development regulations and the underlying SBMC, could be found to be consistent with the General Plan and could be found, as conditioned, to meet the discretionary findings required as discussed in this report to approve a DRP. Therefore, Staff recommends that the City Council:

1. Conduct the Public Hearing: Open the Public Hearing, Report Council Disclosures, Receive Public Testimony, and Close the Public Hearing.
2. Find the project exempt from the California Environmental Quality Act pursuant to Section 15303 of the State CEQA Guidelines; and
3. If the City Council makes the requisite findings and approves the project, adopt **Resolution 2017-166** conditionally approving a Development Review Permit (DRP) modification to allow for the construction of a 894 square foot addition to the existing, one-story, single-family residence and garage at 781 East Solana Circle.

Item B.3. Report (click here)

*Posted Reports & Supplemental Docs contain records up to the cut off time, prior to the start of the meeting, for processing new submittals. The final official record containing handouts, PowerPoints, etc. can be obtained through a Records Request to the City Clerk's Office.*

Councilmember Edson recused herself due to property owned within 500 ft. of proximity of the project.

Corey Andrews, Principal Planner, presented a PowerPoint (on file).

Mayor Marshall opened the public hearing.

Council disclosures.

**Motion:** Moved by Deputy Mayor Zito and second by Mayor Marshall to close the public hearing. **Approved 4/0/1** (Recused: Councilmember Edson). Motion carried.

**Motion:** Moved by Deputy Mayor Zito and second by Mayor Marshall to approve. **Approved 4/0/1** (Recused: Councilmember Edson). Motion carried.

*Mayor Marshall recessed the meeting at 8:10 p.m. for a break and reconvened at 8:16 p.m.*

**B.4. Public Hearing: Introduce (1<sup>st</sup> Reading) Ordinance 484 - Solana Beach Floodplain Overlay Zone to Comply with the National Flood Insurance Program.** (File 0850-20)

Recommendation: That the City Council

1. Conduct the Public Hearing: Open the Public Hearing, Report Council Disclosures, Receive Public Testimony, Close the Public Hearing.
2. If the Council could make the findings as required under SMBC section 17.76.070, introduce **Ordinance 484** to amend the Solana Beach Floodplain Overlay Zone (Sections 17.80.020, 17.80.090 and 17.80.120) of the SBMC.

Item B.4. Report (click here)

*Posted Reports & Supplemental Docs contain records up to the cut off time, prior to the start of the meeting, for processing new submittals. The final official record containing handouts, PowerPoints, etc. can be obtained through a Records Request to the City Clerk's Office.*

Greg Wade, City Manager, introduced the item.

Mayor Marshall opened the public hearing.

Council Disclosures. Mayor Marshall reported that she had sold a home in the past within the project area.

**Motion:** Moved by Deputy Mayor Zito and second by Mayor Marshall to close the public hearing. **Approved 5/0.** Motion carried unanimously.

**Motion:** Moved by Deputy Mayor Zito and second by Councilmember Edson to approve. **Approved 5/0.** Motion carried unanimously.

**C. STAFF REPORTS:** (C.3. - C.5.)

*Submit speaker slips to the City Clerk.*

**C.3. La Colonia Skate Park.** (File 0720-30)

Recommendation: That the City Council

1. Provide feedback on the various design elements including:
  - a. The updated Skate Park design including signage and the donor wall;
  - b. The options for the sound wall and/or noise attenuation barrier along the northern boundary of the Skate Park;
  - c. The full mini full basketball court concepts and alignments; and
2. Adopt **Resolution 2017-159:**
  - a. Finding that the Project is exempt from CEQA pursuant to Section 15332 (In-fill Development Projects) of the State CEQA Guidelines.
  - b. Authorizing the City Engineer to complete the design plans and specifications package and advertise for construction bids.

**Item C.3. Report (click here)**

*Posted Reports & Supplemental Docs contain records up to the cut off time, prior to the start of the meeting, for processing new submittals. The final official record containing handouts, PowerPoints, etc. can be obtained through a Records Request to the City Clerk's Office.*

Greg Wade, City Manager, introduced the item.

Mo Sammak, Public Works/Engineering Dir., presented a PowerPoint (on file).

Council, Staff and Consultants discussed costs, fencing around the basketball court on some or all sides, funding gap, and sound wall options, that 100 ft. of vegetation would be needed to meet the benefits of a sound wall which would be difficult to achieve, and donor wall tiles.

Steve Ostrow stated that a new mini-full basketball court would be an upgrade from the half court located at Fletcher Cove, that replacing a half court with a mini full court would add an enhanced element to the park, that 16 or 20 ft. cage fence was for proximity to traffic which this area did not have so 4 ft. might be enough to stop the ball, that the east west design would add a dynamic to the park.

Councilmember and Consultants discussed that the court area was sunk down with significant difference in grade, that trees would have to come out and new trees would be planted, and that the slope and trees would help control balls flying out of the court.

Council and Staff discussed the dimensional differences between a half court of mini full court, that the bid could include both a half and a mini full court, and to consider including alternate bids or the entire base bid package.

**Motion:** Moved by Deputy Mayor Zito and second by Councilmember Edson to approve with feedback and direction provided with alternate bid option for the EnergiPlant or as a separate item. **Approved 5/0.** Motion carried unanimously.

**C.4. Adopt (2<sup>nd</sup> Reading) Ordinance 483 Establishing a Community Choice Aggregation (CCA) Program.** (File 1010-40)

Recommendation: That the City Council

1. Adopt **Ordinance 483** to establish the Solana Beach CCA program.

Item C.4. Report (click here)

*Posted Reports & Supplemental Docs contain records up to the cut off time, prior to the start of the meeting, for processing new submittals. The final official record containing handouts, PowerPoints, etc. can be obtained through a Records Request to the City Clerk's Office.*

Johanna Canlas, City Attorney, read the title of the ordinance.

Mayor Marshall stated that her position was the same as before, that clean air was great, the City was small and it would be adding another level of government, and was concerned about cost implications.

**Motion:** Moved by Councilmember Edson and second by Councilmember Nichols to approve. **Approved 4/1 (Noes: Marshall).** Motion carried.

**C.5. Adopt (2<sup>nd</sup> Reading) Ordinance 482 Related to Minimum Average Workspace.**  
(File 0610-10)

*This item was pulled from this agenda, after posting, and was not heard.*

**COMPENSATION & REIMBURSEMENT DISCLOSURE:**

GC: Article 2.3. Compensation: 53232.3. (a) Reimbursable expenses shall include, but not be limited to, meals, lodging, and travel. 53232.3 (d) Members of a legislative body shall provide brief reports on meetings attended at the expense of the local agency at the next regular meeting of the legislative body.

Councilmember Edson reported that she traveled to Washington D.C. for meetings regarding funding for Beach Replenishment Project and the City reimbursed the costs.

**COUNCIL COMMITTEE REPORTS:**

**Regional Committees: (outside agencies, appointed by this Council)**

- a. City Selection Committee (meets twice a year) – Nichols (Edson, alternate).

- b. County Service Area 17 – Marshall (Nichols, alternate).
- c. Escondido Creek Watershed Authority – Marshall/Staff (no alternate).
- d. League of Ca. Cities' San Diego County Executive Committee – Nichols (Edson, alternate) and any subcommittees.
- e. League of Ca. Cities' Local Legislative Committee – Nichols (Edson, alternate)
- f. League of Ca. Cities' Coastal Cities Issues Group (CCIG) – Nichols (Edson, alternate)
- g. North County Dispatch JPA – Marshall (Edson, alternate).
- h. North County Transit District – Edson (Nichols, alternate)
- i. Regional Solid Waste Association (RSWA) – Nichols (Hegenauer, alternate).
- j. SANDAG – Zito (Primary), Edson (1<sup>st</sup> alternate), Nichols (2<sup>nd</sup> alternate) and any subcommittees.
- k. SANDAG Shoreline Preservation Committee – Zito (Hegenauer, alternate).
- l. San Dieguito River Valley JPA – Hegenauer (Nichols, alternate).
- m. San Elijo JPA – Marshall, Zito (City Manager, alternate).
- n. 22<sup>nd</sup> Agricultural District Association Community Relations Committee – Marshall, Edson.

**Standing Committees: (All Primary Members) (Permanent Committees)**

- a. Business Liaison Committee – Zito, Edson.
- b. Solana Beach-Del Mar Relations Committee – Nichols, Zito
- c. Highway 101 / Cedros Ave. Development Committee – Edson, Nichols.
- d. Fire Dept. Management Governance & Organizational Evaluation – Edson, Hegenauer
- e. I-5 Construction Committee – Zito, Edson.
- f. Parks and Recreation Committee – Nichols, Zito
- g. Public Arts Committee – Marshall, Hegenauer.
- h. School Relations Committee – Nichols, Hegenauer.

**ADJOURN:**

Mayor Marshall adjourned the meeting at 9:25 p.m.

Angela Ivey, City Clerk

Approved: \_\_\_\_\_



# STAFF REPORT CITY OF SOLANA BEACH

**TO:** Honorable Mayor and City Councilmembers  
**FROM:** Gregory Wade, City Manager  
**MEETING DATE:** February 14, 2018  
**ORIGINATING DEPT:** Finance  
**SUBJECT:** Register of Demands

## BACKGROUND:

Section 3.04.020 of the Solana Beach Municipal Code requires that the City Council ratify a register of demands which represents all financial demands made upon the City for the applicable period.

Register of Demands- 01/06/18 through 01/26/18		
Check Register-Disbursement Fund (Attachment 1)		\$ 4,414,083.64
Council Payroll	January 11, 2018	3,551.25
Federal & State Taxes	January 11, 2018	349.07
PERS Retirement (EFT)	January 11, 2018	518.00
Net Payroll	January 12, 2018	220,662.49
Federal & State Taxes	January 12, 2018	74,084.85
PERS Retirement (EFT)	January 12, 2018	39,503.12
Retirement Payroll	January 15, 2018	9,561.00
Net Payroll	January 26, 2018	139,803.24
Federal & State Taxes	January 26, 2018	39,151.38
PERS Retirement (EFT)	January 26, 2018	38,032.36
		<hr/>
TOTAL		\$ <u>4,979,300.40</u>

## DISCUSSION:

Staff certifies that the register of demands has been reviewed for accuracy, that funds are available to pay the above demands, and that the demands comply with the adopted budget.

## CEQA COMPLIANCE STATEMENT:

Not a project as defined by CEQA.

## FISCAL IMPACT:

The register of demands for January 6, 2018 through January 26, 2018 reflects total expenditures of \$4,979,300.40 from various City funding sources.

CITY COUNCIL ACTION: _____ _____
-------------------------------------



**WORK PLAN:**

N/A

**OPTIONS:**

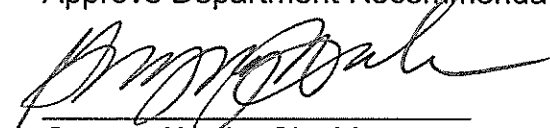
- Ratify the register of demands.
- Do not ratify and provide direction.

**DEPARTMENT RECOMMENDATION:**

Staff recommends that the City Council ratify the above register of demands.

**CITY MANAGER'S RECOMMENDATION:**

Approve Department Recommendation.

  
\_\_\_\_\_  
Gregory Wade, City Manager

Attachments:

1. Check Register – Disbursement Fund

PENTAMATION  
 DATE: 01/25/2018  
 TIME: 17:31:43

CITY OF SOLANA BEACH, CA  
 CHECK REGISTER - DISBURSEMENT FUND

PAGE NUMBER: 1  
 ACCTPA21

SELECTION CRITERIA: transact.ck\_date between '20180106 00:00:00.000' and '20180126 00:00:00.000'  
 ACCOUNTING PERIOD: 7/18

FUND - 001 - GENERAL FUND

CASH ACCT	CHECK NO	ISSUE DT	VENDOR	NAME	BUDGET UNIT	DESCRIPTION	SALES TAX	AMOUNT
1011	91717	01/11/18	4153	AEP CALIFORNIA LLC	00160006170	HEAD LIGHT FLASH RPR	0.00	97.50
1011	91718	01/11/18	2137	AFLAC	001	DECEMBER 17	0.00	980.68
1011	91719	01/11/18	4832	AT&T CALNET 3	00160006150	939112275 11/24-12/23	0.00	164.24
1011	91719	01/11/18	4832	AT&T CALNET 3	00160006170	939153651 11/25-12/24	0.00	213.74
1011	91719	01/11/18	4832	AT&T CALNET 3	00160006120	939112280 11/24-12/23	0.00	333.34
	TOTAL CHECK						0.00	711.32
1011	91720	01/11/18	2526	BARTEL ASSOCIATES, LLC	00150005300	GASB74&75 FY17 CALC	0.00	1,700.00
1011	91720	01/11/18	2526	BARTEL ASSOCIATES, LLC	00150005300	GASB74&75 FY17 CALC	0.00	7,000.00
1011	91720	01/11/18	2526	BARTEL ASSOCIATES, LLC	00150005300	GASB74&75 FY17 CALC	0.00	9,900.00
	TOTAL CHECK						0.00	18,600.00
1011	91721	01/11/18	5320	BAYSHORE CONSULTING GROU	45999055550	9905.02 PROF SVC-DEC	0.00	1,200.00
1011	91722	01/11/18	3480	BUSINESS PRINTING COMPAN	00160006140	BUS CARD-JEMISON	0.00	79.74
1011	91726	01/11/18	1914	US BANK	00160006170	LAMINATING SHEET	0.00	2.14
1011	91726	01/11/18	1914	US BANK	00170007110	TREE LIGHT-REFRESHMNT	0.00	3.98
1011	91726	01/11/18	1914	US BANK	00150005200	CLOSED SESSION-11/08	0.00	8.00
1011	91726	01/11/18	1914	US BANK	00150005250	CLOSED SESSION-11/08	0.00	8.00
1011	91726	01/11/18	1914	US BANK	00150005200	CARDS	0.00	9.35
1011	91726	01/11/18	1914	US BANK	00165006530	PWI-WATER	0.00	9.68
1011	91726	01/11/18	1914	US BANK	00150005450	HOSTING DOMAINS-NOV	0.00	9.95
1011	91726	01/11/18	1914	US BANK	00150005300	CLOSED SESSION-11/08	0.00	10.00
1011	91726	01/11/18	1914	US BANK	00150005150	UNION TRIB-ORD478 BAL	0.00	10.16
1011	91726	01/11/18	1914	US BANK	00150005200	CLOSED SESSION-11/15	0.00	14.25
1011	91726	01/11/18	1914	US BANK	00150005250	CLOSED SESSION-11/15	0.00	14.25
1011	91726	01/11/18	1914	US BANK	00165006560	CAR WASH	0.00	16.99
1011	91726	01/11/18	1914	US BANK	00160006170	TOTE/TAPE	0.00	17.16
1011	91726	01/11/18	1914	US BANK	00160006120	BOOT POLISH	0.00	19.37
1011	91726	01/11/18	1914	US BANK	00170007110	TREE LIGHT-REFRESHMNT	0.00	19.90
1011	91726	01/11/18	1914	US BANK	00150005300	FILING FEE-SB PUB FAC	0.00	20.00
1011	91726	01/11/18	1914	US BANK	00160006120	HEADSET REPAIR SHPPNG	0.00	22.35
1011	91726	01/11/18	1914	US BANK	00150005200	CM MEETING-WADE-10/31	0.00	25.99
1011	91726	01/11/18	1914	US BANK	00155005550	CDEV BOOK	0.00	28.99
1011	91726	01/11/18	1914	US BANK	00155005550	SANDAG-CHOPIK-11/09	0.00	30.00
1011	91726	01/11/18	1914	US BANK	00160006170	EMSTA-URUBURU	0.00	30.00
1011	91726	01/11/18	1914	US BANK	00165006510	APWA-11/09-GOLDBERG	0.00	30.00
1011	91726	01/11/18	1914	US BANK	25560006180	OTLF TEST/COVE/RECEPT	0.00	30.03
1011	91726	01/11/18	1914	US BANK	00160006170	AMERICAN FLAG	0.00	31.20
1011	91726	01/11/18	1914	US BANK	00160006170	PATCHES-SR LFEGUARDS	0.00	38.97
1011	91726	01/11/18	1914	US BANK	00165006510	ENG LIC-GOLDBERG	0.00	41.00
1011	91726	01/11/18	1914	US BANK	00150005450	CONSTANT CONTACT-OCT	0.00	45.00
1011	91726	01/11/18	1914	US BANK	00150005150	LABELS	0.00	46.86
1011	91726	01/11/18	1914	US BANK	00170007110	CPRS WRKSHPP-WENG/MOSH	0.00	50.00
1011	91726	01/11/18	1914	US BANK	00150005100	CLOSED SESSION-11/08	0.00	55.14
1011	91726	01/11/18	1914	US BANK	00150005150	UNION TRIB-ORD477 NOT	0.00	55.47
1011	91726	01/11/18	1914	US BANK	00160006120	FLASHLIGHT BATTERIES	0.00	65.95
1011	91726	01/11/18	1914	US BANK	00150005400	PANEL LUNCH-11/16	0.00	73.72
1011	91726	01/11/18	1914	US BANK	00150005400	EMP APPREC-ACTIVITY	0.00	75.00

PENTAMATION  
 DATE: 01/25/2018  
 TIME: 17:31:43

CITY OF SOLANA BEACH, CA  
 CHECK REGISTER - DISBURSEMENT FUND

PAGE NUMBER: 2  
 ACCTPA21

SELECTION CRITERIA: transact.ck\_date between '20180106 00:00:00.000' and '20180126 00:00:00.000'  
 ACCOUNTING PERIOD: 7/18

FUND - 001 - GENERAL FUND

CASH ACCT	CHECK NO	ISSUE DT	VENDOR	NAME	BUDGET UNIT	DESCRIPTION	SALES TAX	AMOUNT
1011	91726	01/11/18	1914	US BANK	50900007700	ENG LIC-GOLDBERG	0.00	75.00
1011	91726	01/11/18	1914	US BANK	13560006120	WEIGHT EQUIPMENT	0.00	79.00
1011	91726	01/11/18	1914	US BANK	00160006170	HOTSCHEDULES-NOV	0.00	90.00
1011	91726	01/11/18	1914	US BANK	00165006520	UNION TRIB-RES WASTE	0.00	103.80
1011	91726	01/11/18	1914	US BANK	00150005100	CLOSED SESSION-11/15	0.00	104.20
1011	91726	01/11/18	1914	US BANK	00165006570	PAINT SINK	0.00	104.95
1011	91726	01/11/18	1914	US BANK	00170007110	TREE LIGHT-DECORTNS	0.00	112.06
1011	91726	01/11/18	1914	US BANK	00170007110	TREE LIGHT-REFRESHMT	0.00	116.80
1011	91726	01/11/18	1914	US BANK	00155005550	UNION TRIB-CA PLAN NO	0.00	121.87
1011	91726	01/11/18	1914	US BANK	00160006170	2 ADAPTERS-UNI SOLD	0.00	124.66
1011	91726	01/11/18	1914	US BANK	00150005150	IIMC MEMBERSHP-PAVOLA	0.00	125.00
1011	91726	01/11/18	1914	US BANK	00150005150	IIMC MEMBERSHIP-BAVIN	0.00	125.00
1011	91726	01/11/18	1914	US BANK	00150005200	BEREAVEMENT FLOWERS	0.00	133.53
1011	91726	01/11/18	1914	US BANK	00150005300	WEB-EXCEL PIVOT TBL	0.00	149.00
1011	91726	01/11/18	1914	US BANK	00160006120	OPEN HOUSE-PIZZA	0.00	162.50
1011	91726	01/11/18	1914	US BANK	001	SUGA-BERKOTI-12/04-05	0.00	175.00
1011	91726	01/11/18	1914	US BANK	001	SUGA-BENKON-12/04-05	0.00	175.00
1011	91726	01/11/18	1914	US BANK	00160006120	CLEANER	0.00	213.00
1011	91726	01/11/18	1914	US BANK	00170007110	VET DAY REFRESHMNTS	0.00	223.15
1011	91726	01/11/18	1914	US BANK	00150005400	CARIB FOR EE BADGES	0.00	226.04
1011	91726	01/11/18	1914	US BANK	00150005150	ARCHIVE FILING TABS	0.00	251.57
1011	91726	01/11/18	1914	US BANK	00160006170	HANDHELD GPS	0.00	254.68
1011	91726	01/11/18	1914	US BANK	00165006570	GARAGE DOOR TEST-PW	0.00	267.20
1011	91726	01/11/18	1914	US BANK	00170007110	CAMERA	0.00	269.36
1011	91726	01/11/18	1914	US BANK	00150005150	ARCHIVE TAPE TO CD	0.00	270.00
1011	91726	01/11/18	1914	US BANK	001	STORMWATER-MO/GRE/BOR	0.00	300.00
1011	91726	01/11/18	1914	US BANK	00160006120	TWLS/BAGS/TSSUE/CLNR	0.00	325.07
1011	91726	01/11/18	1914	US BANK	00165006570	CIRCULATING PUMP-FD	0.00	354.89
1011	91726	01/11/18	1914	US BANK	00170007110	TREE LIGHT-COSTUME	0.00	383.05
1011	91726	01/11/18	1914	US BANK	001	NICHOLS-DC-12/04	0.00	497.60
1011	91726	01/11/18	1914	US BANK	001	WADE-DC-12/04	0.00	497.60
	TOTAL CHECK						0.00	7,379.43
1011	91727	01/11/18	2846	CALIFORNIA CHAMBER OF CO	00150005400	LABOR LAW POSTERS	0.00	301.08
1011	91728	01/11/18	1561	CDW GOVERNMENT INC	00150005450	WINDOWS SRVR LICENSE	0.00	142.16
1011	91729	01/11/18	5051	CINTAS CORPORATION NO. 2	00165006570	FIRST AID SUPPLIES-CH	0.00	123.98
1011	91730	01/11/18	2631	CLEAN STREET	00165006550	STREET SWP-DEC	0.00	3,173.00
1011	91731	01/11/18	2427	COMPRESSED AIR SPECIALTY	00160006120	COMPRESSOR MAINT	0.00	1,837.40
1011	91732	01/11/18	91	COUNTY OF SAN DIEGO	00160006130	Q3 ANIMAL CNTRL SVC	0.00	20,695.75
1011	91733	01/11/18	127	COX COMMUNICATIONS INC	00150005450	CTVINTRNT 12/19-01/18	0.00	536.68
1011	91734	01/11/18	134	DIXIELINE LUMBER CO INC	00165006530	SCREWS/WHEELS	0.00	10.05
1011	91734	01/11/18	134	DIXIELINE LUMBER CO INC	00165006530	SLIP PREVENTION TAPE	0.00	15.31
1011	91734	01/11/18	134	DIXIELINE LUMBER CO INC	00165006530	CLR CLEANER	0.00	25.85
	TOTAL CHECK						0.00	51.21

PENTAMATION  
 DATE: 01/25/2018  
 TIME: 17:31:43

CITY OF SOLANA BEACH, CA  
 CHECK REGISTER - DISBURSEMENT FUND

PAGE NUMBER: 3  
 ACCTPA21

SELECTION CRITERIA: transact.ck\_date between '20180106 00:00:00.000' and '20180126 00:00:00.000'  
 ACCOUNTING PERIOD: 7/18

FUND - 001 - GENERAL FUND

CASH ACCT	CHECK NO	ISSUE DT	VENDOR	NAME	BUDGET UNIT	DESCRIPTION	SALES TAX	AMOUNT
1011	91735	01/11/18	2062	ENTERPRISE RENT A CAR	27060006120	STRIKETM-12/11-BARRON	0.00	620.78
1011	91736	01/11/18	167	GOVERNMENT FINANCE OFFCR	00150005300	MMB MBRSH DUES 2018	0.00	190.00
1011	91737	01/11/18	1792	HARRIS & ASSOC. INC.	21355005550	1714.08 101/DAHL EIR	0.00	905.00
1011	91738	01/11/18	4166	HOGAN LAW APC	00150005250	22ND DIST AG-NOV	0.00	130.00
1011	91739	01/11/18	11	ICMA RETIREMENT TRUST-45 001		ICMA PD 01/11/18	0.00	5,638.93
1011	91739	01/11/18	11	ICMA RETIREMENT TRUST-45 001		ICMA PD 01/12/18	0.00	7,432.60
	TOTAL CHECK						0.00	13,071.53
1011	91740	01/11/18	3859	ICMA RETIREMENT TRUST-RH 001		ICMA PD 01/12/18	0.00	2,036.03
1011	91741	01/11/18	1075	IRON MOUNTAIN	00150005150	RECORDS STRG-JAN	0.00	418.82
1011	91742	01/11/18	87	ISLA VERDE HOA	20575007530	LANDSCAPE MAINT-DEC	0.00	425.00
1011	91743	01/11/18	4165	KANE BALLMER & BERKMAN	65278007810	SA PROF SVC PE 11/30	0.00	1,050.00
1011	91744	01/11/18	2433	KRC ROCK, INC	00170007100	ENTRY STONE CRANE	0.00	380.00
1011	91745	01/11/18	2887	LANCE, SOLL & LUNGHARD, L	50900007700	FY17 AUDIT SVC	0.00	1,949.08
1011	91745	01/11/18	2887	LANCE, SOLL & LUNGHARD, L	00150005300	FY17 AUDIT SVC	0.00	3,446.92
1011	91745	01/11/18	2887	LANCE, SOLL & LUNGHARD, L	65278007810	FY17 AUDIT SVC (SA)	0.00	2,387.00
1011	91745	01/11/18	2887	LANCE, SOLL & LUNGHARD, L	26355005580	FY17 HOUSING AUDIT	0.00	200.00
	TOTAL CHECK						0.00	7,983.00
1011	91746	01/11/18	172	LEE'S LOCK & SAFE INC	00165006570	SHED LOCK REPAIR-LC	0.00	107.00
1011	91747	01/11/18	2102	LEGAL SHIELD CORP	001	PPD LEGAL-NOV 17	0.00	90.65
1011	91747	01/11/18	2102	LEGAL SHIELD CORP	001	PPD LEGAL-DEC 17	0.00	90.65
	TOTAL CHECK						0.00	181.30
1011	91748	01/11/18	3955	ARNOLD A LEWIN	00160006150	CERT CONSULT-CY2017	0.00	1,505.00
1011	91749	01/11/18	1130	MCDUGAL LOVE ECKIS SMIT	65278007820	APPRDBL HSNG-OCT	0.00	122.50
1011	91749	01/11/18	1130	MCDUGAL LOVE ECKIS SMIT	26399465580	9946 500SRRRA PE10/31	0.00	262.50
	TOTAL CHECK						0.00	385.00
1011	91750	01/11/18	1130	MCDUGAL LOVE ECKIS SMIT	00150005250	PROF SERV PE 10/31/17	0.00	3,100.32
1011	91751	01/11/18	1130	MCDUGAL LOVE ECKIS SMIT	00150005250	PROF SERV PE 10/31/17	0.00	910.00
1011	91752	01/11/18	1130	MCDUGAL LOVE ECKIS SMIT	00150005250	PROF SERV PE 10/31/17	0.00	420.00
1011	91753	01/11/18	1130	MCDUGAL LOVE ECKIS SMIT	00150005250	PROF SERV PE 10/31/17	0.00	5,729.27
1011	91754	01/11/18	1130	MCDUGAL LOVE ECKIS SMIT	00150005250	PROF SERV PE 10/31/17	0.00	140.00
1011	91755	01/11/18	1130	MCDUGAL LOVE ECKIS SMIT	00150005250	PROF SERV PE 10/31/17	0.00	1,301.30

PENTAMATION  
 DATE: 01/25/2018  
 TIME: 17:31:43

CITY OF SOLANA BEACH, CA  
 CHECK REGISTER - DISBURSEMENT FUND

PAGE NUMBER: 4  
 ACCTPA21

SELECTION CRITERIA: transact.ck\_date between '20180106 00:00:00.000' and '20180126 00:00:00.000'  
 ACCOUNTING PERIOD: 7/18

FUND - 001 - GENERAL FUND

CASH ACCT	CHECK NO	ISSUE DT	VENDOR	NAME	BUDGET UNIT	DESCRIPTION	SALES TAX	AMOUNT
1011	91756	01/11/18	1130	MCDUGAL LOVE ECKIS SMIT	00150005250	PROF SERV PE 10/31/17	0.00	437.50
1011	91757	01/11/18	1130	MCDUGAL LOVE ECKIS SMIT	00150005250	PROF SERV PE 10/31/17	0.00	15.00
1011	91758	01/11/18	1130	MCDUGAL LOVE ECKIS SMIT	00150005250	PROF SERV PE 10/31/17	0.00	315.00
1011	91759	01/11/18	1130	MCDUGAL LOVE ECKIS SMIT	00150005250	PROF SERV PE 10/31/17	0.00	1,575.00
1011	91760	01/11/18	1130	MCDUGAL LOVE ECKIS SMIT	12050005460	CLM.1702 PROF SVC-OCT	0.00	146.40
1011	91761	01/11/18	1130	MCDUGAL LOVE ECKIS SMIT	00150005250	PROF SERV PE 10/31/17	0.00	560.00
1011	91762	01/11/18	1130	MCDUGAL LOVE ECKIS SMIT	00150005250	PROF SERV PE 10/31/17	0.00	5,500.00
1011	91763	01/11/18	2106	MIKHAIL OGAWA ENGINEERIN	001650006520	JURMP-DEC	0.00	4,014.21
1011	91763	01/11/18	2106	MIKHAIL OGAWA ENGINEERIN	001650006520	JURMP-NOV	0.00	7,582.96
TOTAL CHECK							0.00	11,597.17
1011	91764	01/11/18	5219	JERUSALEM CONSTRUCTION,	459	9371.17 SDWLK RLS RET	0.00	1,139.75
1011	91765	01/11/18	111	MISSION LINEN & UNIFORM	21100007600	LAUNDRY-PUB WORKS	0.00	1.81
1011	91765	01/11/18	111	MISSION LINEN & UNIFORM	50900007700	LAUNDRY-PUB WORKS	0.00	7.25
1011	91765	01/11/18	111	MISSION LINEN & UNIFORM	00165000560	LAUNDRY-PUB WORKS	0.00	8.16
1011	91765	01/11/18	111	MISSION LINEN & UNIFORM	00165000520	LAUNDRY-PUB WORKS	0.00	8.16
1011	91765	01/11/18	111	MISSION LINEN & UNIFORM	00165000530	LAUNDRY-PUB WORKS	0.00	14.50
TOTAL CHECK							0.00	39.88
1011	91766	01/11/18	50	OFFICE DEPOT INC	00155005560	CARDSTOCK	0.00	36.58
1011	91766	01/11/18	50	OFFICE DEPOT INC	00155005560	FILE FOLDER POCKETS	0.00	318.01
TOTAL CHECK							0.00	354.59
1011	91767	01/11/18	3529	PARKHOUSE TIRE INC	00160006120	TRK#237-TIRE	0.00	915.90
1011	91768	01/11/18	5361	HABITAT PROTECTION, INC	00165000570	PEST CONTROL-DEC-LC	0.00	30.00
1011	91768	01/11/18	5361	HABITAT PROTECTION, INC	00165000570	PEST CONTROL-DEC-FC	0.00	30.00
1011	91768	01/11/18	5361	HABITAT PROTECTION, INC	00165000570	PEST CONTROL-DEC-PW	0.00	30.00
1011	91768	01/11/18	5361	HABITAT PROTECTION, INC	00165000570	PEST CONTROL-DEC-MS	0.00	30.00
1011	91768	01/11/18	5361	HABITAT PROTECTION, INC	00165000570	PEST CONTROL-DEC-FD	0.00	35.00
1011	91768	01/11/18	5361	HABITAT PROTECTION, INC	00165000570	PEST CONTROL-DEC-CH	0.00	45.00
TOTAL CHECK							0.00	200.00
1011	91769	01/11/18	1008	PSC, LLC	001650006520	HHW-NOV	0.00	458.20
1011	91769	01/11/18	1008	PSC, LLC	001650006520	HHW-DEC	0.00	650.50
TOTAL CHECK							0.00	1,108.70
1011	91770	01/11/18	676	QUALA-TEL ENTERPRISES	00160006120	HEADSET REPAIRS	0.00	391.30
1011	91771	01/11/18	4080	JENNIFER REED	00150005350	ADMIN SVC-DEC	0.00	236.25
1011	91772	01/11/18	416	REGIONAL COMMS SYS, MS 0	00160006120	CAP CODE-DEC	0.00	32.50
1011	91773	01/11/18	86	SAN ELIJO HILLS II HOA	20775007550	LANDSCAPE MAINT-DEC	0.00	6,550.00

CITY OF SOLANA BEACH, CA  
CHECK REGISTER - DISBURSEMENT FUND

PENTAMATION  
DATE: 01/25/2018  
TIME: 17:31:43

SELECTION CRITERIA: transact.ck\_date between '20180106 00:00:00.000' and '20180126 00:00:00.000'  
ACCOUNTING PERIOD: 7/18

FUND - 001 - GENERAL FUND

CASH ACCT	CHECK NO	ISSUE DT	VENDOR	NAME	BUDGET UNIT	DESCRIPTION	SALES TAX	AMOUNT
1011	91774	01/11/18	88	SANTA FE HILLS HOA	20475007520	LANDSCAPE MAINT-DEC	0.00	12,250.00
1011	91775	01/11/18	141	SANTA FE IRRIGATION DIST	00160006120	005512000 1102-010218	0.00	527.12
1011	91776	01/11/18	156	SHARP REES-STEALY MEDICA	00150005400	PRE-EMPLOYMNT SCREEN	0.00	142.50
1011	91777	01/11/18	153	SHELL FLEET MANAGEMENT	00160006120	AUTO FUEL-NOV	0.00	1,512.72
1011	91777	01/11/18	153	SHELL FLEET MANAGEMENT	00160006120	CR EXEMPT TAX-NOV	0.00	-114.72
	TOTAL CHECK						0.00	1,398.00
1011	91778	01/11/18	13	SOLANA BEACH FIREFIGHTER 001		FD DUES PD 01/12/18	0.00	823.50
1011	91779	01/11/18	3199	SOUTH COAST EMERGENCY VE	00160006120	APPARATUS RPR-12/19	0.00	718.88
1011	91780	01/11/18	1231	STAPLES CONTRACT & COMME	00150005350	PAPER/PENS	0.00	289.75
1011	91780	01/11/18	1231	STAPLES CONTRACT & COMME	00150005300	BINDERS	0.00	43.08
1011	91780	01/11/18	1231	STAPLES CONTRACT & COMME	50900007700	DESK CALENDAR/STAPLER	0.00	41.68
	TOTAL CHECK						0.00	374.51
1011	91781	01/11/18	450	SWRCB	00165006520	ANNL PRMT-FY18	0.00	2,088.00
1011	91782	01/11/18	2759	TRISTAR RISK MANAGEMENT	12550005465	FY18 CLAIMS SRVC-Q3	0.00	6,250.00
1011	91783	01/11/18	1458	THE UNIFORM SPECIALIST	00160006120	HANCOCK-PNTS/SHRT/BLT	0.00	1,138.69
1011	91784	01/11/18	2097	UT SAN DIEGO - NRTH COUN	00155005550	PUB HRNG-1717.23 DRP	0.00	189.46
1011	91784	01/11/18	2097	UT SAN DIEGO - NRTH COUN	00150005150	ORD 483-ADOPT	0.00	43.48
1011	91784	01/11/18	2097	UT SAN DIEGO - NRTH COUN	00150005150	ORD 484- INTRO	0.00	46.05
	TOTAL CHECK						0.00	278.99
1011	91785	01/11/18	30	VERIZON WIRELESS-SD	00150005450	IT CELL 11/24-12/23	0.00	114.03
1011	91786	01/11/18	3723	WAGEWORKS	00150005400	FSA ADMIN-DEC	0.00	113.00
1011	91787	01/18/18	4786	12MILESOUT.COM	00150005450	COUNCIL WEB STRM-DEC	0.00	800.00
1011	91788	01/18/18	4706	24 HOUR ELEVATOR, INC	00165006570	ELVTR MAINT-JAN	0.00	157.48
1011	91789	01/18/18	5375	AAUW DEL MAR LEUCADIA BR	00150005100	COMM GRANT FY17/18	0.00	5,000.00
1011	91790	01/18/18	4711	ABEL PEREZ	00165006540	MILEAGE-12/26/17	0.00	6.63
1011	91791	01/18/18	5137	ABLE PATROL & GUARD, INC	00170007110	FCCC SECURITY-DEC 17	0.00	125.00
1011	91792	01/18/18	1135	AFFORDABLE PIPELINE SERV	50900007700	C-SEWER CLEAN-44,717	0.00	22,358.50
1011	91793	01/18/18	4800	ASSISTANCE LEAG RNCHO SA	00150005100	COMM GRANT FY 17/18	0.00	3,000.00
1011	91794	01/18/18	4832	AT&T CALNET 3	00150005450	939112282 11/24-12/23	0.00	19.03
1011	91795	01/18/18	4832	AT&T CALNET 3	00150005450	939112278 11/24-12/23	0.00	2,204.31

PENTAMATION  
 DATE: 01/25/2018  
 TIME: 17:31:43

CITY OF SOLANA BEACH, CA  
 CHECK REGISTER - DISBURSEMENT FUND

PAGE NUMBER: 6  
 ACCTPA21

SELECTION CRITERIA: transact.ck\_date between '20180106 00:00:00.000' and '20180126 00:00:00.000'  
 ACCOUNTING PERIOD: 7/18

FUND - 001 - GENERAL FUND

CASH ACCT	CHECK NO	ISSUE DT	VENDOR	NAME	BUDGET UNIT	-----DESCRIPTION-----	SALES TAX	AMOUNT
1011	91796	01/18/18	4832	AT&T CALNET 3	00150005450	939153641 11/24-12/23	0.00	164.24
1011	91797	01/18/18	4832	AT&T CALNET 3	00150005450	939162899 11/24-12/23	0.00	164.24
1011	91798	01/18/18	5320	BAYSHORE CONSULTING GROU	45999055550	9905.02 PROF SVC-DEC	0.00	1,162.50
1011	91799	01/18/18	2424	BJ'S RENTALS	00165006560	TILLER-LCP	0.00	89.81
1011	91800	01/18/18	3716	BOYS & GIRLS CLUB	00150005100	COMM GRANTS FY17/18	0.00	5,000.00
1011	91801	01/18/18	3480	BUSINESS PRINTING COMPAN	00150005350	WINDOW ENVELOPES	0.00	327.65
1011	91802	01/18/18	2853	CASA DE AMISTAD	00150005100	COMM GRANT FY 17/18	0.00	5,000.00
1011	91803	01/18/18	693	CODE PUBLISHING COMPANY	00150005150	MUNI CODE UPDAT-12/17	0.00	504.60
1011	91804	01/18/18	2854	COMMUNITY RESOURCE CENTE	00150005100	COMM GRANT FY 17/18	0.00	5,000.00
1011	91805	01/18/18	3902	CORODATA RECORDS MANAGEM	00150005150	RECORDS STRG-DEC	0.00	312.42
1011	91806	01/18/18	5210	COUNTY OF SAN DIEGO	00160006140	PRKNG CITE ADMIN-NOV	0.00	3,264.26
1011	91807	01/18/18	1747	DFM ASSOCIATES INC	00150005150	2017 CA ELECTION CODE	0.00	160.88
1011	91808	01/18/18	4684	DIVISION OF THE STATE AR	001	DAE FEE OCT-DEC 2017	0.00	223.80
1011	91809	01/18/18	94	ESGIL CORPORAATION	00160006120	FIRE PRMT 08/07-08/11	0.00	1,057.74
1011	91809	01/18/18	94	ESGIL CORPORAATION	00155005560	BLDG PRMT 11/27-12/01	0.00	6,519.10
1011	91809	01/18/18	94	ESGIL CORPORAATION	00155005560	BLDG PRMT 08/07-08/11	0.00	9,293.33
1011	91809	01/18/18	94	ESGIL CORPORAATION	00160006120	FIRE PRMT 11/27-12/01	0.00	927.90
TOTAL	CHECK						0.00	17,798.07
1011	91810	01/18/18	5374	JL STORMWATER CONSULTANT	001	QSD/QSP TRN-BORRO-2/7	0.00	500.00
1011	91811	01/18/18	111	MISSION LINEN & UNIFORM	21100007600	LAUNDRY-PUB WORKS	0.00	1.81
1011	91811	01/18/18	111	MISSION LINEN & UNIFORM	50900007700	LAUNDRY-PUB WORKS	0.00	7.25
1011	91811	01/18/18	111	MISSION LINEN & UNIFORM	00165006520	LAUNDRY-PUB WORKS	0.00	8.16
1011	91811	01/18/18	111	MISSION LINEN & UNIFORM	00165006560	LAUNDRY-PUB WORKS	0.00	8.16
1011	91811	01/18/18	111	MISSION LINEN & UNIFORM	00165006530	LAUNDRY-PUB WORKS	0.00	14.50
TOTAL	CHECK						0.00	39.88
1011	91812	01/18/18	5215	N. C. IMMIGRATION & CITI	00150005100	COMM GRANT FY 17/18	0.00	5,000.00
1011	91813	01/18/18	3908	NATIONAL DOCUMENT SOLUTI	00150005300	W2/1099/ENVELOPES	0.00	215.96
1011	91814	01/18/18	4522	NISSHO OF CALIFORNIA	00165006530	STREET LNDSCP SVC-DEC	0.00	1,170.89
1011	91814	01/18/18	4522	NISSHO OF CALIFORNIA	00165006560	PRKS LNDSCP SVC-DEC	0.00	9,794.51
1011	91814	01/18/18	4522	NISSHO OF CALIFORNIA	00165006570	PUBFAC LNDSCP SVC-DEC	0.00	1,398.10
1011	91814	01/18/18	4522	NISSHO OF CALIFORNIA	20375007510	MID#33 LNDSCP SVC-DEC	0.00	6,448.14
1011	91814	01/18/18	4522	NISSHO OF CALIFORNIA	20875007580	CRT LNDSCP SVC-DEC	0.00	8,782.94
TOTAL	CHECK						0.00	27,594.58

CITY OF SOLANA BEACH, CA  
CHECK REGISTER - DISBURSEMENT FUND

SELECTION CRITERIA: transact.ck\_date between '20180106 00:00:00.000' and '20180126 00:00:00.000'  
ACCOUNTING PERIOD: 7/18

FUND - 001 - GENERAL FUND

CASH ACCT	CHECK NO	ISSUE DT	VENDOR	NAME	BUDGET UNIT	DESCRIPTION	SALES TAX	AMOUNT
1011	91815	01/18/18	2163	NORTH COAST REPERTORY TH	250550055570	COMM GRANT FY 17/18	0.00	5,000.00
1011	91816	01/18/18	4797	PAMELA ELLIOTT LANDSCAPE	213550055550	1714.30/234 S RIOS	0.00	250.00
1011	91816	01/18/18	4797	PAMELA ELLIOTT LANDSCAPE	213550055550	1716.31/826 SEABRIGHT	0.00	250.00
1011	91816	01/18/18	4797	PAMELA ELLIOTT LANDSCAPE	213550055550	1717.10/301 WEST CLIF	0.00	250.00
1011	91816	01/18/18	4797	PAMELA ELLIOTT LANDSCAPE	213550055550	1717.20/729 BARBARA	0.00	250.00
1011	91816	01/18/18	4797	PAMELA ELLIOTT LANDSCAPE	213550055550	1712.21/225 PACIFIC	0.00	250.00
1011	91816	01/18/18	4797	PAMELA ELLIOTT LANDSCAPE	213550055550	1716.30/635 CANYON	0.00	250.00
1011	91816	01/18/18	4797	PAMELA ELLIOTT LANDSCAPE	213550055550	1717.19/980 AVOCADO	0.00	250.00
1011	91816	01/18/18	4797	PAMELA ELLIOTT LANDSCAPE	213550055550	1716.46/314 BARBARA	0.00	250.00
1011	91816	01/18/18	4797	PAMELA ELLIOTT LANDSCAPE	213550055550	1717.07/801 GENEVIEVE	0.00	250.00
1011	91816	01/18/18	4797	PAMELA ELLIOTT LANDSCAPE	213550055550	1716.21/454 S NARDO	0.00	250.00
1011	91816	01/18/18	4797	PAMELA ELLIOTT LANDSCAPE	213550055550	1716.10/216 OCEAN	0.00	250.00
1011	91816	01/18/18	4797	PAMELA ELLIOTT LANDSCAPE	213550055550	1716.21/454 S NARDO	0.00	250.00
1011	91816	01/18/18	4797	PAMELA ELLIOTT LANDSCAPE	213550055550	1716.46/314 BARBARA	0.00	375.00
1011	91816	01/18/18	4797	PAMELA ELLIOTT LANDSCAPE	213550055550	1716.27/360 N GRANADO	0.00	375.00
1011	91816	01/18/18	4797	PAMELA ELLIOTT LANDSCAPE	213550055550	1717.37/607 N CEDROS	0.00	375.00
1011	91816	01/18/18	4797	PAMELA ELLIOTT LANDSCAPE	213550055550	1717.42/456 NARDO	0.00	375.00
1011	91816	01/18/18	4797	PAMELA ELLIOTT LANDSCAPE	213550055550	1717.05/425 S RIOS	0.00	375.00
1011	91816	01/18/18	4797	PAMELA ELLIOTT LANDSCAPE	213550055550	1717.27/235-245 PACIF	0.00	375.00
1011	91816	01/18/18	4797	PAMELA ELLIOTT LANDSCAPE	213550055550	1716.48/1051 WOODSIDE	0.00	375.00
1011	91816	01/18/18	4797	PAMELA ELLIOTT LANDSCAPE	213550055550	1716.48/1051 WOODSIDE	0.00	500.00
TOTAL CHECK							0.00	6,125.00
1011	91817	01/18/18	4767	PARTNERSHIPS WITH INDUST	001650065670	TRASH ABTMT PE12/31	0.00	946.34
1011	91818	01/18/18	113	PITNEY BOWES GLOBAL FINA	00150005150	POSTAG MTR-10/30-1/29	0.00	609.06
1011	91819	01/18/18	1382	PURE FLO - PW # 26118	00165006570	DRINK WATER-DEC	0.00	30.56
1011	91820	01/18/18	4799	REALITY CHANGERS	00150005100	COMM GRANT FY 17/18	0.00	5,000.00
1011	91821	01/18/18	314	SAN ELIJO JPA	001	FY 17 SEJPA CLS OUT	0.00	1,216.00
1011	91821	01/18/18	314	SAN ELIJO JPA	50900007700	Q3 MAINT & OP	0.00	351,687.00
1011	91821	01/18/18	314	SAN ELIJO JPA	50900007700	Q3 CIP FUNDING	0.00	71,902.00
1011	91821	01/18/18	314	SAN ELIJO JPA	001	FY 17 SEJPA CLS OUT	0.00	-1,691.00
1011	91821	01/18/18	314	SAN ELIJO JPA	509	FY 17 SEJPA CLS OUT	0.00	-1,531.00
TOTAL CHECK							0.00	421,583.00
1011	91823	01/18/18	141	SANTA FE IRRIGATION DIST	00165006560	005506000 1102-010218	0.00	106.05
1011	91823	01/18/18	141	SANTA FE IRRIGATION DIST	00165006560	005506001 1102-010218	0.00	81.05
1011	91823	01/18/18	141	SANTA FE IRRIGATION DIST	00165006560	005506002 1102-010218	0.00	443.90
1011	91823	01/18/18	141	SANTA FE IRRIGATION DIST	20875007580	005506003 1102-010218	0.00	-410.09
1011	91823	01/18/18	141	SANTA FE IRRIGATION DIST	00165006560	005506004 1102-010218	0.00	81.05
1011	91823	01/18/18	141	SANTA FE IRRIGATION DIST	00165006560	005506005 1102-010218	0.00	214.83
1011	91823	01/18/18	141	SANTA FE IRRIGATION DIST	00165006560	005506006 1102-010218	0.00	129.83
1011	91823	01/18/18	141	SANTA FE IRRIGATION DIST	00165006560	005506007 1102-010218	0.00	94.19
1011	91823	01/18/18	141	SANTA FE IRRIGATION DIST	00165006570	005506008 1102-010218	0.00	391.34
1011	91823	01/18/18	141	SANTA FE IRRIGATION DIST	00165006560	005506009 1102-010218	0.00	81.05
1011	91823	01/18/18	141	SANTA FE IRRIGATION DIST	00165006560	005506010 1102-010218	0.00	107.33
1011	91823	01/18/18	141	SANTA FE IRRIGATION DIST	00165006560	005506011 1102-010218	0.00	316.88





PENTAMATION  
 DATE: 01/25/2018  
 TIME: 17:31:43

CITY OF SOLANA BEACH, CA  
 CHECK REGISTER - DISBURSEMENT FUND

SELECTION CRITERIA: transact.ck\_date between '20180106 00:00:00.000' and '20180126 00:00:00.000'  
 ACCOUNTING PERIOD: 7/18

FUND - 001 - GENERAL FUND

CASH ACCT	CHECK NO	ISSUE DT	VENDOR	NAME	BUDGET UNIT	DESCRIPTION	SALES TAX	AMOUNT
1011	91835	01/18/18	2656	NORMAN & PAT WALKER	001	RFND-FCCC 1/6/18	0.00	500.00
1011	91836	01/18/18	4844	WARWICK GROUP CONSULTANT	45099266190	9926-PROF SVC-DEC	0.00	5,375.00
1011	91837	01/18/18	1512	WELLS FARGO BANK N.A.	67285008520	PACIFC END INT 3/2/18	0.00	10,447.51
1011	91837	01/18/18	1512	WELLS FARGO BANK N.A.	67185008510	BARB BND INT 3/2/18	0.00	30,973.76
1011	91837	01/18/18	1512	WELLS FARGO BANK N.A.	671	LSS RV FND CSH 3/2/18	0.00	-32.59
	TOTAL CHECK						0.00	41,388.68
1011	91838	01/18/18	4763	WESTERN AUDIO VISUAL	00150005450	CHAMBERS TECH-DEC	0.00	499.00
1011	91839	01/22/18	5050	US BANK FBO CITY OF SOLA	001	ACT#001050993448 DEP	0.00	3,500,000.00
1011	91840	01/25/18	1122	APPLE ONE, INC	00150005150	TEMP HELP PE 01/06	0.00	202.05
1011	91840	01/25/18	1122	APPLE ONE, INC	00150005150	TEMP HELP PE 01/06	0.00	215.52
1011	91840	01/25/18	1122	APPLE ONE, INC	00150005150	TEMP HELP PE 12/16	0.00	356.96
1011	91840	01/25/18	1122	APPLE ONE, INC	00150005150	TEMP HELP PE 12/16	0.00	484.92
1011	91840	01/25/18	1122	APPLE ONE, INC	00150005150	TEMP HELP PE 12/09	0.00	942.90
1011	91840	01/25/18	1122	APPLE ONE, INC	00150005150	TEMP HELP PE 12/02	0.00	969.84
	TOTAL CHECK						0.00	3,172.19
1011	91841	01/25/18	2008	BICKMORE	120	FY 18 WC CSAC SUBSIDY	0.00	-2,000.00
1011	91841	01/25/18	2008	BICKMORE	12550005465	FY18 WC ACTUARIAL SVC	0.00	4,250.00
	TOTAL CHECK						0.00	2,250.00
1011	91842	01/25/18	2555	BOB HOFFMAN VIDEO PRODUC	00150005450	COUNCL MTG-7/12-11/15	0.00	5,440.00
1011	91843	01/25/18	5378	CA INDEPENDENT SYSTEM OP	45999055550	9905.02 CCA-CRR APP	0.00	1,000.00
1011	91847	01/25/18	1914	US BANK	00150005150	SVC CHRGE-COUNTY CLRK	0.00	0.90
1011	91847	01/25/18	1914	US BANK	00150005150	MAYOR ROTATN COLLAGE	0.00	2.99
1011	91847	01/25/18	1914	US BANK	00150005100	WATERS FOR COUNCIL	0.00	4.49
1011	91847	01/25/18	1914	US BANK	00150005150	MAYOR ROTATN COLLAGE	0.00	7.99
1011	91847	01/25/18	1914	US BANK	00150005400	GIFT TAGS - EE APPREC	0.00	7.99
1011	91847	01/25/18	1914	US BANK	001	DC-WADE-COFFEE	0.00	8.64
1011	91847	01/25/18	1914	US BANK	00165005530	PWI WATER	0.00	9.28
1011	91847	01/25/18	1914	US BANK	00160005170	EXACTO KNIFE/STENCILS	0.00	9.68
1011	91847	01/25/18	1914	US BANK	00150005450	HOSTING DOMAINS-DEC	0.00	9.95
1011	91847	01/25/18	1914	US BANK	00165005570	PUMP OIL-FIRE STATION	0.00	9.99
1011	91847	01/25/18	1914	US BANK	00150005150	MAYOR ROTATN FLOWERS	0.00	10.76
1011	91847	01/25/18	1914	US BANK	00150005150	COPIES-COUNTY CLERK	0.00	12.00
1011	91847	01/25/18	1914	US BANK	001	DC-WADE-MEAL	0.00	13.38
1011	91847	01/25/18	1914	US BANK	00150005150	MAYOR GIFT WRAP	0.00	13.98
1011	91847	01/25/18	1914	US BANK	00160005170	STORAGE TUB	0.00	14.54
1011	91847	01/25/18	1914	US BANK	00165005510	APWA-GOLDBERG-11/30	0.00	15.00
1011	91847	01/25/18	1914	US BANK	001	DC-WADE-CAR	0.00	15.23
1011	91847	01/25/18	1914	US BANK	00150005200	CLOSED SESSION-12/13	0.00	15.79
1011	91847	01/25/18	1914	US BANK	00150005250	CLOSED SESSION-12/13	0.00	15.79
1011	91847	01/25/18	1914	US BANK	00150005200	SCHOOL REL MTG-12/07	0.00	15.95
1011	91847	01/25/18	1914	US BANK	00170007110	TREE LGHTG-VOL COFFEE	0.00	15.95
1011	91847	01/25/18	1914	US BANK	00150005200	LA TIMES SUB	0.00	15.96
1011	91847	01/25/18	1914	US BANK	00160005120	GASKET/INLET KIT	0.00	16.82

CITY OF SOLANA BEACH, CA  
CHECK REGISTER - DISBURSEMENT FUND

PENTAMATION  
DATE: 01/25/2018  
TIME: 17:31:43

SELECTION CRITERIA: transact.ck\_date between '20180106 00:00:00.000' and '20180126 00:00:00.000'  
ACCOUNTING PERIOD: 7/18

FUND - 001 - GENERAL FUND

CASH ACCT	CHECK NO	ISSUE DT	VENDOR	NAME	BUDGET UNIT	DESCRIPTION	SALES TAX	AMOUNT
1011	91847	01/25/18	1914	US BANK	001	CALPELRA-SAMMAK-12/05	0.00	17.00
1011	91847	01/25/18	1914	US BANK	00150005150	MAYORS COLLAGE FRAME	0.00	21.32
1011	91847	01/25/18	1914	US BANK	00150005150	BADGES-MARSHALL/ZITO	0.00	22.63
1011	91847	01/25/18	1914	US BANK	001	CALPELRA-SAMMAK-12/05	0.00	25.00
1011	91847	01/25/18	1914	US BANK	001	CALPELRA-SAMMAK-12/05	0.00	25.00
1011	91847	01/25/18	1914	US BANK	00150005400	EE MILESTONE-MITCHELL	0.00	25.00
1011	91847	01/25/18	1914	US BANK	00150005400	EE MILESTONE-KOSZEWNK	0.00	25.00
1011	91847	01/25/18	1914	US BANK	00150005400	EE MILESTONE-WONG	0.00	25.00
1011	91847	01/25/18	1914	US BANK	00170007110	TREE LIGHTING-DECORATNS	0.00	28.49
1011	91847	01/25/18	1914	US BANK	00150005150	MAYOR ROTATN-CAKE	0.00	29.50
1011	91847	01/25/18	1914	US BANK	00160006170	EMT RECERT-SHOOK	0.00	30.00
1011	91847	01/25/18	1914	US BANK	00165006510	APWA-KERR-12/13	0.00	30.00
1011	91847	01/25/18	1914	US BANK	001	DC-WADE-CAR	0.00	33.12
1011	91847	01/25/18	1914	US BANK	00150005150	WALL CLOCK/MAG HOLDER	0.00	34.13
1011	91847	01/25/18	1914	US BANK	00160006140	LAMINATING FILM	0.00	36.25
1011	91847	01/25/18	1914	US BANK	00165006510	COMPUTER CLNR	0.00	40.92
1011	91847	01/25/18	1914	US BANK	00150005450	CONSTANT CONTACT-NOV	0.00	45.00
1011	91847	01/25/18	1914	US BANK	00160006120	FILTER KIT	0.00	47.99
1011	91847	01/25/18	1914	US BANK	00150005150	CCAC MTG-IVEY	0.00	50.00
1011	91847	01/25/18	1914	US BANK	00160006120	FILTERS	0.00	54.78
1011	91847	01/25/18	1914	US BANK	001	DC TRIP-WADE-CAR	0.00	55.92
1011	91847	01/25/18	1914	US BANK	00150005150	TAB DIVIDERS	0.00	57.81
1011	91847	01/25/18	1914	US BANK	00160006120	COSTCO MEMBERSHIP	0.00	60.00
1011	91847	01/25/18	1914	US BANK	001	CALPELRA-SAMMAK-12/05	0.00	61.50
1011	91847	01/25/18	1914	US BANK	001	DC TRIP-WADE-CAR	0.00	61.82
1011	91847	01/25/18	1914	US BANK	00160006170	CLNR/SOAP/POLISH	0.00	62.84
1011	91847	01/25/18	1914	US BANK	00150005150	LAMINATING POUCHES	0.00	63.80
1011	91847	01/25/18	1914	US BANK	00170007110	TREE LIGHTING-VOL FOOD	0.00	65.73
1011	91847	01/25/18	1914	US BANK	00150005400	EE APPREC-LUNCH	0.00	71.26
1011	91847	01/25/18	1914	US BANK	00160006140	LAMINATING FILM	0.00	72.50
1011	91847	01/25/18	1914	US BANK	00150005400	EE MILESTONE-GOLDBERG	0.00	75.00
1011	91847	01/25/18	1914	US BANK	00150005200	TRAKIT LUNCH-11/28	0.00	79.49
1011	91847	01/25/18	1914	US BANK	00150005400	EE APPREC-DESSERT	0.00	82.00
1011	91847	01/25/18	1914	US BANK	27060006120	FUEL-THOMAS FIRE	0.00	85.00
1011	91847	01/25/18	1914	US BANK	00150005100	CLOSED SESSION-12/13	0.00	85.88
1011	91847	01/25/18	1914	US BANK	00160006170	HOTSCHEDULES-DEC	0.00	90.00
1011	91847	01/25/18	1914	US BANK	001	DC-WADE/EDSON-MEAL	0.00	95.81
1011	91847	01/25/18	1914	US BANK	27060006120	HEADLAMPS/BATTERIES	0.00	97.98
1011	91847	01/25/18	1914	US BANK	00150005400	EE MILESTONE-SIBERELL	0.00	100.00
1011	91847	01/25/18	1914	US BANK	00165006570	LIGHT BULBS	0.00	114.64
1011	91847	01/25/18	1914	US BANK	00150005300	GAAP UPDATE-BERK/WONG	0.00	135.00
1011	91847	01/25/18	1914	US BANK	00150005400	EE MILESTONE-LOFTIS	0.00	150.00
1011	91847	01/25/18	1914	US BANK	00160006170	PW GARAGE DOOR MAINT	0.00	150.15
1011	91847	01/25/18	1914	US BANK	00165006570	BATTERIES/VEST/GLASSE	0.00	158.87
1011	91847	01/25/18	1914	US BANK	00150005400	ENVELOPS-JOB MAILING	0.00	215.24
1011	91847	01/25/18	1914	US BANK	00170007110	STORAGE BINS-TREE	0.00	233.54
1011	91847	01/25/18	1914	US BANK	00150005300	ACA SOFTWARE	0.00	250.00
1011	91847	01/25/18	1914	US BANK	00150005400	DIR COMDEV JOB POSTNG	0.00	275.00
1011	91847	01/25/18	1914	US BANK	00150005150	LCC-IVEY-12/14	0.00	275.00
1011	91847	01/25/18	1914	US BANK	001	LCC-PAVOLAS-12/13-15	0.00	307.86
1011	91847	01/25/18	1914	US BANK	00150005150	ARCHIVE DVDS	0.00	311.41
1011	91847	01/25/18	1914	US BANK	00160006120	TWLS/CLNR/BAGS/DTGNT	0.00	

PENTAMATION  
 DATE: 01/25/2018  
 TIME: 17:31:43

CITY OF SOLANA BEACH, CA  
 CHECK REGISTER -- DISBURSEMENT FUND

PAGE NUMBER: 11  
 ACCTPA21

SELECTION CRITERIA: transact.ck\_date between '20180106 00:00:00.000' and '20180126 00:00:00.000'  
 ACCOUNTING PERIOD: 7/18

FUND - 001 - GENERAL FUND

CASH ACCT	CHECK NO	ISSUE DT	VENDOR	NAME	BUDGET UNIT	-----DESCRIPTION-----	SALES TAX	AMOUNT
1011	91847	01/25/18	1914	US BANK	00150005400	DIR COMDEV JOB POSTNG	0.00	390.00
1011	91847	01/25/18	1914	US BANK	001	TRAKIT-BERKUTL-12/4-6	0.00	395.72
1011	91847	01/25/18	1914	US BANK	001	TRAKIT-BENSON-12/4-6	0.00	395.72
1011	91847	01/25/18	1914	US BANK	001	DC TRIP-HOTEL-12/04	0.00	548.76
1011	91847	01/25/18	1914	US BANK	00160006170	TIDE BOOKS	0.00	581.88
1011	91847	01/25/18	1914	US BANK	001	DC-WADE-HOTEL	0.00	624.44
1011	91847	01/25/18	1914	US BANK	13560006120	WEIGHTS AND BENCH	0.00	725.36
1011	91847	01/25/18	1914	US BANK	001	DC TRIP-EDSON-FLIGHT	0.00	992.59
1011	91847	01/25/18	1914	US BANK	00160006120	FIRE TSHIRTS	0.00	999.99
	TOTAL CHECK						0.00	10,714.69
1011	91848	01/25/18	1561	CDW GOVERNMENT INC	00150005450	WIRELESS ROUTER	0.00	85.75
1011	91849	01/25/18	4279	CITY PLACE PLANNING, INC	21355005550	1714.08 AAT SOLANA 101	0.00	632.50
1011	91850	01/25/18	211	CONSOLIDATED ELECTRICAL	00165006570	ELECTRONIC TIME SWTCH	0.00	156.24
1011	91851	01/25/18	5171	CORELOGIC SOLUTIONS, LLC	00155005550	PROPERTY PRO DATA	0.00	96.83
1011	91852	01/25/18	2098	CULLIGAN OF SAN DIEGO	00160006170	WATER FLTR 01/01-1/31	0.00	41.60
1011	91853	01/25/18	2629	D & D DISPOSAL INC	00160006130	ANIMAL DISPOSAL-DEC	0.00	65.00
1011	91854	01/25/18	2374	DARIN KUIITE	00150005400	AMERICAN HIST/KUIITE	0.00	660.00
1011	91855	01/25/18	213	DEPARTMENT OF TRANSPORTA	00165006540	MAINT 10/17-12/17	0.00	584.74
1011	91855	01/25/18	213	DEPARTMENT OF TRANSPORTA	00165006540	ELECT 10/17-12/17	0.00	595.14
	TOTAL CHECK						0.00	1,179.88
1011	91856	01/25/18	134	DIXIELINE LUMBER CO INC	00165006570	SPACKLE	0.00	7.75
1011	91857	01/25/18	94	ESGIL CORPORATION	00155005560	BLDG PRMT 11/13-11/17	0.00	9,150.06
1011	91857	01/25/18	94	ESGIL CORPORATION	00155005560	BLDG PRMT 12/04-12/08	0.00	9,927.47
1011	91857	01/25/18	94	ESGIL CORPORATION	00160006120	FIRE PRMT 11/13-11/17	0.00	932.85
1011	91857	01/25/18	94	ESGIL CORPORATION	00160006120	FIRE PRMT 12/04-12/08	0.00	2,105.89
	TOTAL CHECK						0.00	22,116.27
1011	91858	01/25/18	4169	FIRE STATS, LLC	00160006120	FIRE DATA-OCT17-DEC17	0.00	459.00
1011	91859	01/25/18	11	ICMA RETIREMENT TRUST-45	001	ICMA PD 01/26/18	0.00	8,905.21
1011	91860	01/25/18	3859	ICMA RETIREMENT TRUST-RH	001	ICMA PD 01/26/18	0.00	2,036.30
1011	91861	01/25/18	2287	KOPPEL & GRUBER PUBLIC F	20875007580	CRT FEE ASSESSMENT	0.00	324.41
1011	91861	01/25/18	2287	KOPPEL & GRUBER PUBLIC F	21100007600	ST LGHT FEE ASSESMNT	0.00	586.89
	TOTAL CHECK						0.00	911.30
1011	91862	01/25/18	4738	MEDICAL EYE SERVICES	001	EE# JAN 18	0.00	-18.09
1011	91862	01/25/18	4738	MEDICAL EYE SERVICES	00150005400	ROUNDING-JANUARY 18	0.00	-0.21
1011	91862	01/25/18	4738	MEDICAL EYE SERVICES	001	VISION JANUARY	0.00	432.52
1011	91862	01/25/18	4738	MEDICAL EYE SERVICES	001	EE# JAN 18	0.00	19.91
1011	91862	01/25/18	4738	MEDICAL EYE SERVICES	001	EE# JAN 18	0.00	20.33

CITY OF SOLANA BEACH, CA  
CHECK REGISTER - DISBURSEMENT FUND

PENTAMATION  
DATE: 01/25/2018  
TIME: 17:31:43

SELECTION CRITERIA: transact.ck\_date between '20180106 00:00:00.000' and '20180126 00:00:00.000'  
ACCOUNTING PERIOD: 7/18

FUND - 001 - GENERAL FUND

CASH ACCT	CHECK NO	ISSUE DT	VENDOR	NAME	BUDGET UNIT	-----DESCRIPTION-----	SALES TAX	AMOUNT
TOTAL CHECK								
1011	91863	01/25/18	3757	MISAC	00150005450	MICRSFT TRNG-MATHESON	0.00	454.46
1011	91864	01/25/18	111	MISSION LINEN & UNIFORM	21100007600	LAUNDRY-PUB WORKS	0.00	1.81
1011	91864	01/25/18	111	MISSION LINEN & UNIFORM	50900007700	LAUNDRY-PUB WORKS	0.00	7.25
1011	91864	01/25/18	111	MISSION LINEN & UNIFORM	00165006560	LAUNDRY-PUB WORKS	0.00	8.16
1011	91864	01/25/18	111	MISSION LINEN & UNIFORM	00165006520	LAUNDRY-PUB WORKS	0.00	8.16
1011	91864	01/25/18	111	MISSION LINEN & UNIFORM	00165006530	LAUNDRY-PUB WORKS	0.00	14.50
TOTAL CHECK							0.00	39.88
1011	91865	01/25/18	434	NOBLE CONSULTANTS, INC.	45094426510	9442.01 SSCPE STR-DEC	0.00	2,271.00
1011	91866	01/25/18	50	OFFICE DEPOT INC	00150005350	SANITIZER	0.00	10.73
1011	91866	01/25/18	50	OFFICE DEPOT INC	00150005350	FACE MASKS-ANTIVIRAL	0.00	46.28
TOTAL CHECK							0.00	57.01
1011	91867	01/25/18	5354	PILLSBURY WINTHROP SHAW	00150005250	PROF SVC-NOV	0.00	5,123.25
1011	91868	01/25/18	4658	PLACERWORKS, INC	21355005550	1714.20/959 GENEVIEWE	0.00	3,005.00
1011	91869	01/25/18	1087	PREFERRED BENEFIT INS AD 001		EE# COBRA JAN 18	0.00	45.00
1011	91869	01/25/18	1087	PREFERRED BENEFIT INS AD 001		EE# COBRA JAN 18	0.00	45.00
1011	91869	01/25/18	1087	PREFERRED BENEFIT INS AD 001		EE# COBRA JAN 18	0.00	80.70
1011	91869	01/25/18	1087	PREFERRED BENEFIT INS AD 001		DENIAL JANUARY 18	0.00	2,837.60
1011	91869	01/25/18	1087	PREFERRED BENEFIT INS AD 00150005400		ROUNDING JAN 18	0.00	-0.07
1011	91869	01/25/18	1087	PREFERRED BENEFIT INS AD 001		EE TIMING JAN 18	0.00	-3.30
1011	91869	01/25/18	1087	PREFERRED BENEFIT INS AD 001		EE TIMING JAN 18	0.00	-1.80
1011	91869	01/25/18	1087	PREFERRED BENEFIT INS AD 001		EE TIMING JAN 18	0.00	-145.30
TOTAL CHECK							0.00	2,857.83
1011	91870	01/25/18	3307	PURE FLO WATER-LC	00170007110	DRINK WATER-DEC	0.00	5.69
1011	91871	01/25/18	2260	REDFLEX TRAFFIC SYSTEMS,	00165006540	RED LIGHT CAMERA-DEC	0.00	7,158.00
1011	91872	01/25/18	287	SALIENT NETWORKS (FKA DI	13550005450	CISCO CALL MNGR LIC	0.00	3,480.75
1011	91872	01/25/18	287	SALIENT NETWORKS (FKA DI	13550005450	PROF SVC	0.00	12,667.20
1011	91872	01/25/18	287	SALIENT NETWORKS (FKA DI	13550005450	PAGING SFTWR UPGRD	0.00	3,057.60
1011	91872	01/25/18	287	SALIENT NETWORKS (FKA DI	13550005450	RCPT CNSL INTERGRIN	0.00	436.80
1011	91872	01/25/18	287	SALIENT NETWORKS (FKA DI	13550005450	VOICE MAIL INTRGTNS	0.00	3,057.60
TOTAL CHECK							0.00	22,699.95
1011	91873	01/25/18	257	SAN DIEGO COUNTY SHERIFF	00160006110	FY18 CAL ID Q3 & Q4	0.00	1,353.00
1011	91874	01/25/18	3263	SCOTT'S AUTOMOTIVE	00160006170	T2481-MAINT	0.00	56.00
1011	91875	01/25/18	5026	SESAC, INC	25055005570	MUSIC RIGHTS LIC 2018	0.00	417.00
1011	91876	01/25/18	13	SOLANA BEACH FIREFIGHTER	001	FD DUES PD 01/26/18	0.00	823.50
1011	91877	01/25/18	450	SWRCB	00165006520	FY17/18 STRM WTR PRMT	0.00	8,539.00

PENTAMATION  
 DATE: 01/25/2018  
 TIME: 17:31:43

CITY OF SOLANA BEACH, CA  
 CHECK REGISTER - DISBURSEMENT FUND

PAGE NUMBER: 13  
 ACCTPA21

SELECTION CRITERIA: transact.ck\_date between '20180106 00:00:00.000' and '20180126 00:00:00.000'  
 ACCOUNTING PERIOD: 7/18

FUND - 001 - GENERAL FUND

CASH ACCT	CHECK NO	ISSUE DT	VENDOR	NAME	BUDGET UNIT	DESCRIPTION	SALES TAX	AMOUNT
1011	91878	01/25/18	5360	STONEHENGE SIGNS, INC.	001700007100	SOL BCH ENTRY BOULDER	0.00	4,250.00
1011	91879	01/25/18	4465	SUN LIFE FINANCIAL	001	JAN 18 LIFE & ADD INS	0.00	1,000.56
1011	91879	01/25/18	4465	SUN LIFE FINANCIAL	001	JAN 18 LTD	0.00	1,257.49
1011	91879	01/25/18	4465	SUN LIFE FINANCIAL	001	JAN 18 SUPP LIFE INS	0.00	267.10
	TOTAL CHECK						0.00	2,525.15
1011	91880	01/25/18	4534	TRAFFIC SUPPLY, INC	001650006540	NO PARKING SIGNS/TAPE	0.00	544.86
1011	91881	01/25/18	2097	UT SAN DIEGO - NRTH COUN	001500005150	ORD 484-AMEND	0.00	65.11
	TOTAL CASH ACCOUNT						0.00	4,414,083.64
	TOTAL FUND						0.00	4,414,083.64
	TOTAL REPORT						0.00	4,414,083.64



# STAFF REPORT CITY OF SOLANA BEACH

**TO:** Honorable Mayor and City Councilmembers  
**FROM:** Gregory Wade, City Manager  
**MEETING DATE:** February 14, 2018  
**ORIGINATING DEPT:** Finance  
**SUBJECT:** Report on Changes Made to the General Fund Adopted Budget for Fiscal Year 2017-2018

## BACKGROUND:

Staff provides a report at each Council meeting that lists changes made to the current Fiscal Year (FY) General Fund Adopted Budget.

The information provided in this Staff Report lists the changes made through January 24, 2018.

## DISCUSSION:

The following table reports the revenue, expenditures, and transfers for 1) the Adopted General Fund Budget approved by Council on June 14, 2017 (Resolution 2017-095) and 2) any resolutions passed by Council that amended the Adopted General Fund Budget.

GENERAL FUND - ADOPTED BUDGET PLUS CHANGES As of January 24, 2018					
Action	Description	Revenues	Expenditures	Transfers from GF	Net Surplus
Reso 2017-195	Adopted Budget	17,611,600	(16,932,700)	(372,400) (1)	\$ 306,500
Reso 2017-122	Marine Safety MOU	-	(11,340)	-	295,160
Reso 2017-123	Salary and Comp Plan	-	(75,500)	-	219,660
Reso 2017-126	Miscellaneous MOU	-	(53,600)	-	166,060
(1) Transfers to:					
	Debt Service for Public Facilities		152,400		
	City CIP Fund		220,000	372,400	

## CEQA COMPLIANCE STATEMENT:

Not a project as defined by CEQA

COUNCIL ACTION:

---



---

**FISCAL IMPACT:**

N/A

**WORK PLAN:**

N/A

**OPTIONS:**


- Receive the report.
- Do not accept the report

**DEPARTMENT RECOMMENDATION:**

Staff recommends that the City Council receive the report listing changes made to the FY 2017-2018 General Fund Adopted Budget.

**CITY MANAGER'S RECOMMENDATION:**

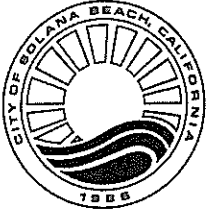
Approve Department Recommendation



---

Gregory Wade, City Manager





# STAFF REPORT CITY OF SOLANA BEACH

**TO:** Honorable Mayor and City Councilmembers  
**FROM:** Gregory Wade, City Manager  
**MEETING DATE:** February 14, 2018  
**ORIGINATING DEPT:** Engineering Department  
**SUBJECT:** **Consideration of Resolution No. 2018-011 Amending the Streetlight Preventative Maintenance and Repair Services Agreement to Increase Funding for Additional Services**

---

## **BACKGROUND:**

In March 2016, Staff issued a Request for Proposals (RFP) via an electronic bid site (ebidboard.com) to solicit proposals from firms qualified to provide maintenance and repair services on the City's streetlights. After evaluating all proposals that were received, the City entered into an agreement with Siemens Industry, Inc., (Siemens) effective July 1, 2016, in an amount not to exceed \$31,700 per year (the "Agreement"). This Agreement included an option for the City to renew the Agreement for four additional years subject to the sole discretion of the City. On July 1, 2017, Amendment No. 1 to the Agreement was executed which extended the term of the Agreement to June 30, 2018. Amendment No.1 did slightly increase the compensation at a price not to exceed \$32,334 per the Agreement. Under the terms of this Agreement, during the past twelve months, Siemens performed required maintenance services as well as any emergency services on City-owned streetlights.

This item is before the City Council to consider adoption of Resolution 2018-011 (Attachment 1), authorizing the City Manager to execute Amendment No. 2 (Attachment 2) to the Professional Services Agreement with Siemens for Streetlight Preventative Maintenance and Repair Services for a one time increase to the compensation by \$37,095 at an amount not to exceed \$69,429 to facilitate the replacement of seven (7) light poles in Eden Gardens community.

## **DISCUSSION:**

The Agreement with Siemens provides for on-going streetlight preventative maintenance and repair services for all City-owned streetlights. It should be noted that the City only owns 527 of the 801 streetlights along the Solana Beach roadway network.

CITY COUNCIL ACTION:

---

---

The remaining 274 streetlights are owned and maintained by SDG&E for which the City pays a yearly fee to SDG&E for operation and maintenance. The Agreement allows for replacement of a limited number of streetlights throughout the year. Recently, however, Staff identified several street lights in the Eden Gardens community that are in need of replacement for which insufficient funds are available in the current contract. The scope of work contemplated by this proposed light pole replacement project is estimated to cost \$37,095 which would exceed the budget of the existing Agreement.

Attachment 3 is a site plan that shows the locations of the streetlight poles that would be replaced by this project. The majority of the poles are along Valley and Genevieve Avenues. The one exception is a damaged pole in La Colonia Park. The poles along Valley and Genevieve Avenues would be funded through the Lighting Maintenance District. Since the Lighting Maintenance District does not allow funding of lights in City parks, the one new pole in La Colonia Park would be funded through the Park Maintenance Operating Budget. Should Council authorize this amendment, funds from these sources would be allocated to this Agreement.

**CEQA COMPLIANCE STATEMENT:**

The project is exempt from the California Environmental Quality Act (CEQA) pursuant to Section 15301(c) of the State CEQA Guidelines.

**FISCAL IMPACT:**

For the one new pole in La Colonia Park, the Fiscal Year (FY) 2017/18 Adopted Budget has allocated sufficient funding to cover the cost of the new pole in the Park Maintenance Operating Budget, so no additional appropriation is needed. For the new poles and fixtures along Valley and Genevieve Avenues, an additional \$33,745 would need to be appropriated from the Lighting District Reserves.

**WORK PLAN:**

This project is not identified in the 2017/18 Work Plan.

**OPTIONS:**

- Approve Staff recommendation.
- Approve Staff recommendation with alternative amendments or modifications.
- Deny Staff recommendation and provide direction.

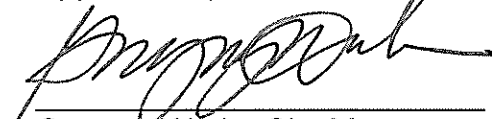
**DEPARTMENT RECOMMENDATION:**

Staff recommends that the City Council Adopt Resolution 2018-011:

1. Authorizing the City Manager to execute Amendment No. 2 to the Professional Services Agreement with Siemens Industry, Inc. for streetlight preventative maintenance and repair services for FY 2017/18 to increase the compensation by \$37,095 for a contract total amount not to exceed \$69,429.
2. Authorizing an appropriation of \$33,745 from the Streetlight District Reserves for partial funding of the amendment to the Agreement with Siemens Industry, Inc.
3. Authorizing the City Treasurer to amend the FY 2017/18 Adopted Budget accordingly.

**CITY MANAGER'S RECOMMENDATION:**

Approve Department Recommendation.



---

Gregory Wade, City Manager

Attachments:

1. Resolution 2018-011
2. Amendment No. 2 to the PSA with Siemens
3. Site plan with pole locations

**RESOLUTION NO. 2018-011**

**A RESOLUTION OF THE CITY COUNCIL OF THE CITY OF SOLANA BEACH, CALIFORNIA, AMENDING THE PROFESSIONAL SERVICES AGREEMENT AMENDMENT WITH SIEMENS INDUSTRY, INC. FOR STREETLIGHT PREVENTATIVE MAINTENANCE AND REPAIR SERVICES**

**WHEREAS**, effective July 1, 2011, the City entered into a Professional Services Agreement (Agreement) with Siemens Industry, Inc., (Siemens) for maintenance and repair services on the City's streetlights; and

**WHEREAS**, the City has executed one amendment to the agreement, with Amendment No. 1 being executed on July 1, 2017 to extend the term of the agreement to June 30, 2018 and to provide a slight increase in the compensation; and

**WHEREAS**, under the terms of the agreement, during the past twelve months, Siemens performed required maintenance services as well as any emergency services on City-owned streetlights; and

**WHEREAS**, the Agreement allows for replacement of all components of a limited number of streetlights throughout the year. However, the scope of work contemplated by this proposed project would exceed the budget of the existing Agreement.

**NOW THEREFORE**, the City Council of the City of Solana Beach, California, does resolve as follows:

1. That the foregoing recitations are true and correct.
2. That the City Council authorizes the City Manager to execute Amendment No. 2 to the Professional Services Agreement with Siemens Industry, Inc. for streetlight preventative maintenance and repair services for Fiscal Year (FY) 2017/18 to increase the compensation by \$37,095 for a contract total amount not to exceed \$69,429.
3. That the City Council authorizes an appropriation of \$33,745 from the Streetlight District Reserves for partial funding of the amendment to the Agreement with Siemens Industry, Inc.

4. That the City Council authorizes the City Treasurer to amend the FY 2017/18 Adopted Budget accordingly.

**PASSED AND ADOPTED** this 14th day of February, 2018, at a regular meeting of the City Council of the City of Solana Beach, California by the following vote:

AYES: Councilmembers –  
NOES: Councilmembers –  
ABSENT: Councilmembers –  
ABSTAIN: Councilmembers –

\_\_\_\_\_  
GINGER MARSHALL, Mayor

APPROVED AS TO FORM:

ATTEST:

\_\_\_\_\_  
JOHANNA N. CANLAS, City Attorney

\_\_\_\_\_  
ANGELA IVEY, City Clerk

**AMENDMENT NO. 2 TO PROFESSIONAL SERVICES AGREEMENT WITH SIEMENS  
INDUSTRY, INC., FOR STREETLIGHT PREVENTATIVE MAINTENANCE AND  
REPAIR SERVICES**

This Amendment No. 2 is entered into and effective as of the \_\_\_\_ day of \_\_\_\_\_, 2018, amending the Agreement for Streetlight Preventative Maintenance and Repair Services (the "Agreement") by and between the City of Solana Beach, a municipal corporation, ("City"), and **Siemens Industry, Inc.**, a State of Delaware Corporation ("Contractor") (collectively, the "Parties").

**RECITALS**

A. On July 1, 2016, the Parties executed the Agreement which included an option for the City to renew the Agreement for a maximum of four (4) additional one-year periods; and

B. On July 1, 2017, the Parties executed Amendment 1 which extended the term of the Agreement to June 30, 2018 and increased the compensation portion at a price not to exceed thirty-two thousand three hundred thirty-four dollars (\$32,334); and

C. After a comprehensive evaluation of the City's inventory, several streetlights were found to be damaged and in need of replacement and costs were not anticipated in Amendment 1 of the Agreement.

D. The City desires to amend the Agreement for a one time increase to the compensation by thirty-seven thousand ninety-five dollars (\$37,095) at a price not to exceed sixty-nine thousand four hundred twenty-nine dollars (\$69,429).

NOW, THEREFORE, in consideration of these recitals and the mutual covenants contained herein, City and Contractor agree as follows:

1. City will pay Contractor for all work associated with the terms of the Agreement which is amended to increase compensation by thirty-seven thousand ninety-five dollars (\$37,095) at a price not to exceed sixty-nine thousand four hundred twenty-nine dollars (\$69,429).

2. All requisite insurance policies to be maintained by the Contractor pursuant to the Agreement, as may have been amended from time to time, shall include coverage for this Amendment.

3. All other provisions of the Agreement, as may have been amended from time to time, shall remain in full force and effect.

4. The individuals executing this Amendment and the instruments referenced on behalf of Contractor each represent and warrant that they have the legal power, right and actual authority to bind Contractor to the terms and conditions hereof of this Amendment.

**SIEMENS INDUSTRY, INC., Contractor**

**CITY OF SOLANA BEACH, a municipal corporation of the State of California**

By:

\_\_\_\_\_  
(Sign here)

\_\_\_\_\_  
Gregory Wade, City Manager

\_\_\_\_\_  
(Print name/title)

\_\_\_\_\_  
(Date)

\_\_\_\_\_  
(Date)

APPROVED AS TO CONTENT:

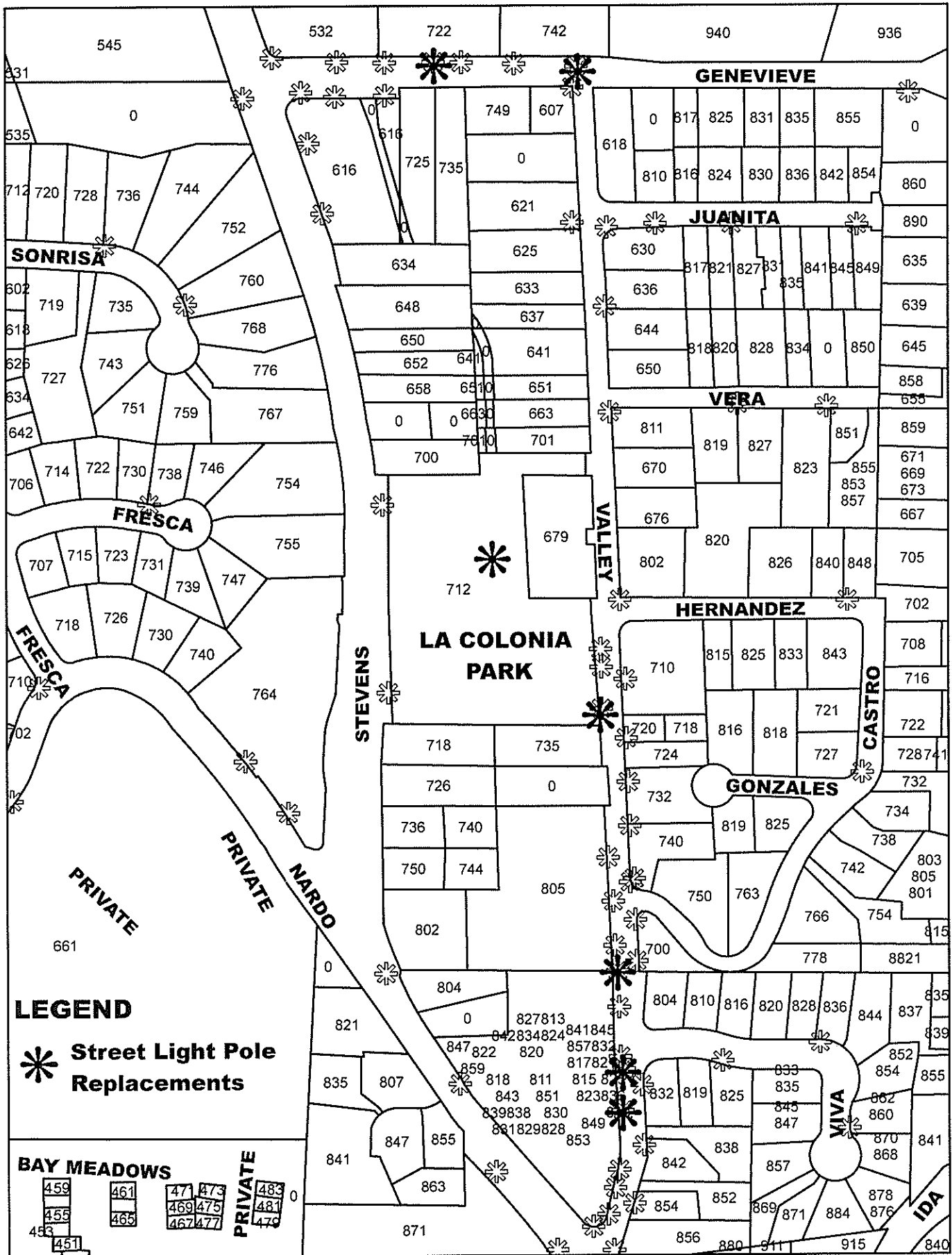
\_\_\_\_\_  
Mohammad Sammak, Director of Engineering and Public Works

APPROVED AS TO FORM:

\_\_\_\_\_  
Johanna Canlas, City Attorney

ATTEST:

\_\_\_\_\_  
Angela Ivey, City Clerk



# DAMAGED STREET LIGHTS TO BE REPLACED

1/25/18





# STAFF REPORT CITY OF SOLANA BEACH

**TO:** Honorable Mayor and City Councilmembers  
**FROM:** Gregory Wade, City Manager  
**MEETING DATE:** February 14, 2018  
**ORIGINATING DEPT:** Community Development Department  
**SUBJECT:** **Public Hearing: CUP/DRP/SDP for a New Wireless Communications Facility at 201 Lomas Santa Fe (Case # 17-17-15 Applicant: AT&T Mobility) Resolution 2017-167**

---

## BACKGROUND:

The Applicant, AT&T Mobility (hereinafter referred to as "Applicant"), is requesting the approval of a Conditional Use Permit (CUP), Development Review Permit (DRP) and Structure Development Permit (SDP) to construct a new Wireless Communication Facility (WCF) on top of an existing commercial office building at 201 Lomas Santa Fe. The Applicant is proposing to increase the height of an existing elevator tower by six inches in order to construct a new antenna enclosure that would conceal eight panel antennas, 24 Remote Radio Units (RRU's), four surge suppressors, and two GPS antennas behind fiber reinforced plastic screening colored and textured to match the existing building. Another antenna enclosure is proposed at the northeast corner of the building behind the existing parapet that would house four antennas and eight RRUs and two surge suppressors. A new ground level equipment enclosure would be installed that would contain four stack-mounted radio equipment cabinets, one power cabinet, one battery cabinet and telephone and electric utility panels on a concrete slab foundation. The enclosure would be located in the location that is currently a landscape planter adjacent to the building entrance. The antenna enclosure would increase the width of the existing tower by 1'-5" and depth of the top 12 feet of the existing tower by three feet and the height by 6 inches. The highest point of the proposed antennas will be 38'-1" above the existing grade and 149.7 feet above the existing grade.

Solana Beach Municipal Code (SBMC) section 17.60.120(G)(1) indicates that all WCF's are subject to a CUP and must comply with City Council Policy 21. A DRP is required for "any new commercial development or construction (including any structural addition to existing development) located within any commercial zone which results in an increase of more than 500 feet of gross floor area or to the overall building envelope." The proposed addition would exceed 16 feet in height from the existing grade and, therefore, requires a Structure Development Permit (SDP).

CITY COUNCIL ACTION:

---

---

---

**AGENDA ITEM B.1.**

This item is before the City Council to approve, conditionally approve or deny the Applicant's request for a CUP, DRP, and SDP for a new WCF at 201 Lomas Santa Fe, as contained in Resolution 2017-167 (Attachment 1).

### **DISCUSSION:**

This project was originally heard at the December 13, 2017 City Council meeting. The original Staff Report has been provided in Attachment 2. At that meeting, the proposed project and several alternative sites were discussed. The Applicant indicated that an existing site on Lomas Santa Fe is being decommissioned and because of that, there would be a significant gap in coverage. By constructing the proposed site at 201 Lomas Santa Fe, that significant gap would be addressed. The federal Telecommunications Act of 1996 indicates that local governments cannot prohibit or effectively prohibit personal wireless communication services. If an Applicant demonstrates that there is a "significant gap" in their service coverage and the proposed site constitutes the "least intrusive means" to mitigate that significant gap, the Ninth Circuit holds that a single permit denial violates the Telecom Act.

After receiving public testimony and evidence regarding the project at the Council meeting, the Council indicated that they were not able to make the finding that the proposed project design constitutes the "least intrusive means" in addressing the gap in coverage. The Council requested that the Applicant provide additional analysis for the project site based on aesthetic concerns. Specifically, the Council requested information regarding the feasibility of separating the antenna sectors and installing several radio frequency (RF) transparent screening boxes on different sides of the structure at lower heights. The Council also requested to see a sample of what the proposed RF transparent screening material would look like to verify that it would in fact match the existing exterior of the structure in color and texture. The Applicant agreed to provide the requested information. The council voted 5/0 to continue the project to a date certain of January 10, 2018.

At the January 10, 2018 City Council meeting, the Applicant presented two project alternatives. Alternative 1 consisted of raising the tower two feet in height, placing an equipment enclosure next to the elevator tower for additional equipment that would increase the height of the parapet by two feet, and moving the eastern facing sector at the northeast corner of the building in a screened box on the outside of the parapet that would increase the height of the parapet by two feet. Alternative 2 consisted of raising the elevator tower two feet to contain three antenna sectors, placing an equipment enclosure next to the elevator tower on the roof raising the parapet by two feet and placing an eastern facing antenna sector on the eastern elevation of the equipment enclosure next to the elevator tower. The Council expressed concerns that the alternatives presented did not constitute the least intrusive means to address the significant gap. The Council requested that the Applicant consider using smaller antennas to reduce the height of the antenna enclosure to the lowest height possible. The Council also requested additional information regarding the tree replacement next to the ground level equipment enclosure and to look into the possibility of removing the existing vegetation along the eastern property line that encroaches into the public right-

of-way. The Council asked the Applicant if they would agree to an extension to the tolling agreement to allow for additional time to review additional onsite project alternatives. The Applicant agreed to a tolling agreement extension. The Council voted 5/0 to continue the project to a date certain on February 14, 2018.

The Applicant held an onsite meeting with the City's Telecom Consultant, the City Manager, and Staff to discuss potential project alternatives on January 25, 2018. At that meeting a new project alternative, Alternative 3, was discussed as well as modifications to the existing landscaping along the eastern elevation and the replacement of the tree south of the existing elevator tower.

Project Alternative 3 incorporates the following changes from the original design:

- The Applicant is proposing to move the eastern sector of the proposed antennas to the northeast corner of the building and install 2'-4" antennas behind and not higher than the existing parapet which would be screened by RF transparent material that is colored and textured to match the existing parapet wall on the building. The existing parapet will look the same as it currently exists, except that the existing 5-inch gap approximately three feet below the top rail along the roofline would be enclosed.
- The three remaining antenna sectors would stay on top of the existing elevator tower, however, the height of the tower would only increase by six inches above the existing roofline. The additional six inches is needed to conceal to coax cable sweep from the RRU's which will be located back to back on the roof just east of the elevator shaft behind a concealment wall at the same height as the existing parapet. Again, an existing five inch gap three feet below the top of the parapet will be enclosed by screening material.
- The Applicant has agreed to remove the existing vegetation that encroaches into the public right-of-way along the eastern property line and in its place the Applicant would construct a vinyl-coated chain link fence in compliance with the fence and wall height regulations. The Applicant would also plant vines that would grow along the fence. As a condition of approval, the fence and vines would require approval of an Encroachment Removal Maintenance Agreement (ERMA) agreement by the City Engineer.
- The Applicant has indicated that they would remove the existing tree that is just south of the existing elevator tower and replace it with a 42" box of the same type of tree that is 20 feet tall and has a nine foot spread at planting.

It should be noted that the City's third-party landscape architect, Pamela Elliott, has indicated that most commercially available trees are no larger than a 48" box which would be approximately 16-18 feet tall, however, she was able to find an 84" box tree that is approximately 22 feet tall. In her opinion planting that sized tree in the reduced landscape planter area as shown on the plans would be nearly impossible and would have a high risk of failure. She has suggested that

a Tristania, Brisbane Box (*Lophostemon confertus*) would be a good replacement tree but even at a 60" box it would only be about 18-20 feet tall.

The Applicant has provided the attached revised project plans and photo simulations to reflect the revisions described above. (Attachment 4)

A draft Resolution has been provided based upon the alternative project design as presented in this report. It includes the applicable SBMC sections in italicized text. The Council may direct Staff to modify the Resolution to reflect the findings and conditions it deems appropriate as a result of the public hearing process.

**CEQA COMPLIANCE STATEMENT:**

The project is exempt from the California Environmental Quality Act (CEQA) pursuant to Section 15301 of the State CEQA Guidelines.

**FISCAL IMPACT:** N/A

**WORK PLAN:** N/A

**OPTIONS:**

- Approve Staff recommendation adopting the attached Resolution 2017-167.
- Approve Staff recommendation subject to additional specific conditions necessary for the City Council to make all required findings for the approval of a DRP.
- Deny the project if all required findings for the DRP cannot be made.

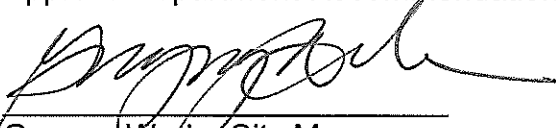
**DEPARTMENT RECOMMENDATION:**

The proposed project meets the minimum zoning requirements under the SBMC, may be found to be consistent with the General Plan and may be found, as conditioned, to meet the discretionary findings required as discussed in this report to approve a DRP. Therefore, Staff recommends that the City Council:

1. Conduct the Public Hearing: Open the Public Hearing, Report Council Disclosures, Receive Public Testimony, and Close the Public Hearing.
2. Find the project exempt from the California Environmental Quality Act pursuant to Section 15301 of the State CEQA Guidelines; and
3. Adopt Resolution 2017-167 conditionally approving a CUP/DRP/SDP for a new WCF and associated equipment located on the roof of an existing commercial office building at 201 Lomas Santa Fe, Solana Beach.

**CITY MANAGER'S RECOMMENDATION:**

Approve Department Recommendation.



---

Gregory Wade, City Manager

Attachments:

1. Resolution 2017-167
2. December 13, 2017 Staff Report
3. January 10, 2018 Staff Report
4. Alternative 3 Project Design Plans

**RESOLUTION NO. 2017-167**

**A RESOLUTION OF THE CITY COUNCIL OF THE CITY OF SOLANA BEACH, CALIFORNIA, CONDITIONALLY APPROVING A CONDITIONAL USE PERMIT, DEVELOPMENT REVIEW PERMIT AND STRUCTURE DEVELOPMENT PERMIT FOR A NEW WIRELESS COMMUNICATIONS FACILITY LOCATED ON THE EXISTING COMMERCIAL STRUCTURE AT 201 LOMAS SANTA FE, SOLANA BEACH**

**APPLICANT: AT&T Mobility**  
**CASE NO.: 17-17-15 CUP/DRP/SDP**

**WHEREAS**, AT&T Mobility (hereinafter referred to as “Applicant”) has submitted an application for a Conditional Use Permit (CUP), Development Review Permit (DRP) and Structure Development Permit (SDP) pursuant to Title 17 (Zoning) of the Solana Beach Municipal Code (SBMC) and City Council Policy 21; and

**WHEREAS**, the Applicant is proposing a new WCF location in order to replace a WCF being removed from the commercial structure at 505 Lomas Santa Fe; and

**WHEREAS**, at the hearing on December 13, 2017, the City Council received and considered evidence concerning the proposed application; and

**WHEREAS**, on December 13, 2017, the public hearing was conducted pursuant to the provisions of Solana Beach Municipal Code Section 17.72.030; and

**WHEREAS**, on December 13, 2017, the City Council continued the project to a date certain no January 11, 2018; and

**WHEREAS**, at the hearing on January 11, 2018, the City Council received and considered evidence concerning two alternative project designs for the proposed application; and

**WHEREAS**, on January 11, 2018, the public hearing was conducted pursuant to the provisions of Solana Beach Municipal Code Section 17.72.030; and

**WHEREAS**, on the City Council continued the project to a date certain on February 14, 2018; and

**WHEREAS**, on February 14, 2018, the public hearing was conducted pursuant to the provisions of Solana Beach Municipal Code Section 17.72.030; and

**WHEREAS**, at the hearing on February 14, 2018, the City Council received and considered evidence regarding the project; and

**WHEREAS**, the City Council of the City of Solana Beach found the application request exempt from the California Environmental Quality Act pursuant to Section 15303 of the State CEQA Guidelines; and

**WHEREAS**, this decision is based upon the evidence presented at the hearings, and any information the City Council gathered by viewing the site and the area as disclosed at the hearing.

**NOW THEREFORE**, the City Council of the City of Solana Beach, California, does resolve as follows:

1. That the foregoing recitations are true and correct.
2. That the request for a CUP/DRP/SDP to construct a new WCF with the north, south and western antenna sectors located on the top of the existing elevator tower that would increase in height by 6 inches, construct the eastern antenna sector on the northeast corner of the roof of the structure with 2.3 foot antennas screened behind Radio Frequency (FR) transparent fiber reinforced plastic (FRP) screening colored and textured to match the existing parapet, remove and replace the existing tree west of the existing elevator tower, and remove the existing vegetation within the public right-of-way along the eastern elevation and construct a fence in its place, and construct a ground level equipment enclosure at the existing commercial office building at 201 Lomas Santa Fe is conditionally approved based upon the following Findings and subject to the following Conditions:

3. FINDINGS

- A. In accordance with Section 17.68.010 (Conditional Use Permit) of the City of Solana Beach Municipal Code, the City Council finds the following:

*1. Before granting a Conditional Use Permit, the Planning Director or City Council shall make all of the following findings:*

- a. The proposed use is in accord with the General Plan, the general intent of this title, and the purposes of the zone in which the site is located.*

General Plan Consistency: The proposed project, as conditioned, is consistent with the City's General Plan designation of Office/Professional which provides for professional office and general office in addition to other compatible uses such as religious facilities, educational institutions, parks and recreation facilities, and public utilities. Further, the proposed development is consistent with the objectives of the General Plan as it encourages the development of commercial land uses which strengthen the City's economic base and offer a range of commercial enterprises to meet the needs of the residents and visitors.

Zoning Ordinance Consistency: The proposed project is consistent with all applicable requirements of the Zoning Ordinance (Title 17), which delineates Permitted Uses and Structures (SBMC Section 17.24.020 and 17.24.030), and provides for uses which allow an Applicant to locate a commercial transmission and receiving antenna on a property within the OP Zone. Further, the proposed project adheres to all property development regulations established for the OP Zone and cited by the SBMC Section 17.24.030.

The design of the proposed project is consistent with the provisions for minimum yard dimensions (i.e. setbacks) and maximum building height. The project also complies with City Council 21 regulations as required by SBMC Section 17.60.120 for height, setbacks, proximity to residential uses, the uses of surrounding properties, quality and compatibility of design and screening, and impacts to public views and visual quality of the surrounding areas.

- b. *The proposed use, together with the conditions applicable thereto, will not be detrimental to the public health, safety, or welfare, or materially injurious to properties or improvements in the vicinity.*

The Applicant has submitted an updated third party Radio Frequency Safety Survey Report Prediction prepared by Waterford Compliance dated March 30, 2017. This report indicates that there would be a controlled access zone extending approximately 34 feet horizontally from the face of the antennas at roughly the height of the antennas at all four antenna sectors. The existence of the controlled access zone does not mean that the project violates the FCC rules; rather, it indicates that the carrier must affirmatively restrict public access to that area so that members of the general population (including trespassers) cannot unknowingly enter and be exposed to radio emissions in excess of those allowed by the FCC. Therefore, the project will not be detrimental to the public health, safety or welfare, or materially injurious to properties or improvement in the vicinity as determined by the FCC based on its exposure limits.

- c. *That the proposed use complies with each of the applicable provision of the zoning ordinance, unless a variance is granted pursuant to SBMC 17.68.020*

The proposed project complies with the property development regulations of SBMC 17.24.030, as well as the Wireless Communications Facilities guidelines of City Council Policy 21,



which are required according to SBMC Section 17.60.120 for maximum height, setbacks, proximity to residential properties, impacts on public views and visual quality of the surrounding area.

- II. *If the Conditional Use Permit is for the purpose of permitting an expansion, restoration or extension of a nonconforming use or structure then only the findings of Chapter 17.16 SBMC must be made.*

The proposed project is not for the purpose of permitting an expansion, restoration or extension of a nonconforming use or structure.

- B. In accordance with Section 17.68.040 (Development Review Permit) of the City of Solana Beach Municipal Code, the City Council finds the following:

- I. *The proposed project is consistent with the General Plan and all applicable requirements of SBMC Title 17 (Zoning Ordinance), including special regulations, overlay zones, and specific plans.*

General Plan Consistency: The proposed project, as conditioned, is consistent with the City's General Plan designation of Office/Professional which provides for professional office and general office in addition to other compatible uses such as religious facilities, educational institutions, parks and recreation facilities, and public utilities. Further, the proposed development is consistent with the objectives of the General Plan as it encourages the development of commercial land uses which strengthen the City's economic base and offer a range of commercial enterprises to meet the needs of the residents and visitors.

Zoning Ordinance Consistency: The proposed project is consistent with all applicable requirements of the Zoning Ordinance (Title 17), which delineates Permitted Uses and Structures (SBMC Section 17.24.020 and 17.24.030), and provides for uses which allow an Applicant to locate a commercial transmission and receiving antenna on a property within the OP Zone. Further, the proposed project adheres to all property development regulations established for the OP Zone and cited by the SBMC Section 17.24.030.

The design of the proposed project is consistent with the provisions for minimum yard dimensions (i.e. setbacks) and maximum building height. The project also complies with City Council 21 regulations as required by SBMC Section 17.60.120 for height, setbacks, proximity to residential uses, the uses of surrounding properties, quality and compatibility of design and

screening, and impacts to public views and visual quality of the surrounding areas.

II. *The proposed development complies with the following development review criteria set forth in Solana Beach Municipal Code Section 17.68.040(F):*

- a. *Relationship with Adjacent Land Uses: The development shall be designed in a manner compatible with and complementary to existing development in the immediate vicinity of the project site and the surrounding neighborhood. The development as proposed shall also be compatible in scale, apparent bulk, and massing with such existing development in the surrounding neighborhood. Site planning on or near the perimeter of the development shall give consideration to the protection of surrounding areas from potential adverse effects.*

The property is located within the OP Zone and the SAOZ. Properties to the west are located within the Special Commercial (SC) Zone and developed with the Minute Shop liquor store, to the north are in the Light Commercial Zone and are developed with a two story mixed retail and office building. Properties to the east are located within the Low Medium Residential (LMR) Zone and to the south properties are within the Low Residential (LR) Zone. The residentially zoned lots are developed with a mix of one and two story, single family residences. The project site is currently developed with a multi-level office building with a parking lot located towards the southern property line. The project, as designed, is consistent with the specific development standards of the OP Zone as described in SBMC Sections 17.24.010 and 17.12.020. The proposed development could be found to be consistent with the objectives of the General Plan as it encourages the development of commercial land uses which strengthen the City's economic base and offer a range of commercial enterprises to meet the needs of the residents and visitors.

The property is located within the SAOZ, however, as mentioned previously can be found exempt from the specific requirements of the overlay zone because it is a minor modification. As a condition of project approval, the Applicant would be required to obtain a Coastal Development Permit, Waiver or Exemption from the California Coastal Commission prior to the issuance of a Building Permit.

- b. *Building and Structure Placement: Buildings and structures shall be sited and designed to minimize adverse impacts on the surrounding properties and designed in a manner which visually and functionally enhance their intended use and complement existing site topography.*

*Multi-family residential buildings shall be sited to avoid crowding and to allow for a functional use of the space between buildings.*

The proposed WCF addition would increase the height, depth, and width of the existing elevator enclosure in order to provide space to install three antennas in three sectors and associated equipment. The fourth antenna sector would be provided behind proposed screening on the northeast corner of the roof of the structure. The soil and vegetation will be removed from an existing planter area at the ground level in order to provide a below grade equipment enclosure.

The OP Zone has required setbacks of 15 feet for the front, 15 feet for a street side and 15 feet for the rear when it is abutting residentially zoned properties. As designed the proposed equipment enclosure would be setback approximately 70 feet from Lomas Santa Fe and the antenna enclosure would be setback approximately 90 feet. The maximum building height for the OP zone is 45 feet as measured from the lower of the existing or proposed grade, the tallest point of the proposed antenna enclosure would be approximately 38'-1" above the existing grade directly adjacent to the enclosure.

- c. *Landscaping: The removal of significant native vegetation shall be minimized. Replacement vegetation and landscaping shall be compatible with the vegetation of the surrounding area. To the maximum extent practicable, landscaping and plantings shall be used to screen parking areas, storage areas, access roads, and other service uses of the site. Trees and other large plantings shall not obstruct significant views when installed or at maturity. Drought tolerant plant materials and water conserving irrigation systems shall be incorporated into all landscaping plans.*

The project is not subject to the water efficient landscaping regulations of SBMC Chapter 17.56. According to SBMC Section 17.56.040, the regulations apply to modified irrigated landscaped areas that exceed 500 square feet. As designed, approximately 158 square feet of landscaped area will be removed in order to construct the equipment enclosure. The Applicant would remove a portion of the existing retaining wall that surrounds an existing landscape planter and excavate the soil and remove the existing vegetation in order to pour a concrete slab. In addition, an existing tree adjacent to the proposed equipment enclosure would be removed and replaced with the proposed project. The Applicant will remove the existing tree that is just south of the existing elevator tower and replace it with a 42" box of the same type of tree that is 20 feet tall and has a nine foot spread at planting.

The Applicant has also agreed to the existing vegetation that encroaches into the public right-of-way along the eastern property line and in its place the Applicant would construct a chain link fence in compliance with the fence and wall height regulations. The Applicant would also plant vines that would grow along the fence. As a condition of approval, the fence and vines would have an Encroachment Removal Maintenance Agreement (ERMA) agreement with the City Engineer.

- d. *Roads, Pedestrian Walkways, Parking and Storage Areas: Any development involving more than one building or structure shall provide common access roads and pedestrian walkways. Parking and outside storage areas, where permitted, shall be screened from view, to the extent feasible, by existing topography, by the placement of buildings and structures, or by landscaping and plantings.*

No additional parking is required for an unmanned WCF.

- e. *Grading: To the extent feasible, natural topography and scenic features of the site shall be retained and incorporated into the proposed development. Any grading or earth-moving operations in connection with the proposed development shall be planned and executed so as to blend with the existing terrain both on and adjacent to the site. Existing exposed or disturbed slopes shall be landscaped with native or naturalized non-native vegetation and existing erosion problems shall be corrected.*

The proposed grading quantities include 29.4 cubic yards for the excavation to be exported off-site in order to remove the existing plant and soil from the planter box and construct a below grade equipment enclosure for the proposed WCF.

- f. *Lighting: Light fixtures for walkways, parking areas, driveways, and other facilities shall be provided in sufficient number and at proper locations to assure safe and convenient nighttime use. All light fixtures shall be appropriately shielded so that no light or glare is transmitted or reflected in such concentrated quantities or intensities as to be detrimental to the surrounding areas per SBMC 17.60.060 (Exterior Lighting Regulations).*

A condition of project approval includes that all new exterior lighting fixtures comply with the City-Wide Lighting Regulations of the Zoning Ordinance (SBMC 17.60.060). All light fixtures shall be shielded so that no light or glare is transmitted or reflected in such concentrated quantities or intensities as to be detrimental to the surrounding area.

- g. Usable Open Space: Recreational facilities proposed within required usable open space shall be located and designed to maintain essential open space values.*

The project consists of the construction of a new WCF on an existing office building, therefore, usable open space and recreational facilities are neither proposed nor required according to SBMC Section 17.20.040.

- III. All required permits and approvals issued by the City, including variances, conditional use permits, comprehensive sign plans, and coastal development permits, have been obtained prior to or concurrently with the development review permit.*

All required permits, including the DRP and SDP, are being processed concurrently with the CUP. As a condition of project approval, the Applicant shall obtain approval from the CCC prior to issuance of Building Permits.

- IV. If the development project also requires a permit or approval to be issued by a state or federal agency, the city council may conditionally approve the development review permit upon the applicant obtaining the required permit or approval from the other agency.*

As a condition of project approval, the Applicant will be required to obtain approval from the California Coastal Commission (CCC) prior to the issuance of Building Permits.

- C. In accordance with Section 17.63.040 (Structure Development Permit) of the Solana Beach Municipal Code, the City Council finds the following:

- I. Notices were mailed to all property owners and residents within 300 feet of the property and the deadline to file for View Assessment was November 22, 2017. No applications for View Assessment were received.

Therefore, the requirements for the approval of a SDP have been met. The SDP will be issued administratively with the CUP and DRP. The Applicant has since reduced the above ground height of the proposed elevator tower enclosure extension to approximately XX feet above the existing grade.

As a condition of project approval, once construction has begun, the Applicant will be required to submit a height certification prior to the framing inspection. The Height Certification will be signed by a licensed land surveyor and will verify that the framing materials and the proposed roofing materials will not exceed the maximum building

height of 38'-1" from the existing grade or 149.7 feet above MSL as approved by the SDP.

#### 4. CONDITIONS

Prior to use or development of the property in reliance on this permit, the Applicant shall provide for and adhere to the following conditions:

A. Community Development Department Conditions:

- I. Building Permit plans must be in substantial conformance with the plans presented to the City Council on February 14, 2018, located in the project file with a submittal date of February 6, 2018.
- II. The Applicant shall obtain required California Coastal Commission (CCC) approval of a Coastal Development Permit, Waiver or Exemption as determined necessary by the CCC, prior to the issuance of a building permit.
- III. Any new exterior lighting fixtures shall be in conformance with the City-Wide Lighting Regulations of SBMC 17.60.060.
- IV. All light fixtures shall be appropriately shielded so that no light or glare is transmitted or reflected in such concentrated quantities or intensities that render them detrimental to the surrounding area.
- V. This permit will automatically expire 10 years and one day from its issuance, except when California Government Code § 65964(b), as may be amended or superseded in the future, authorizes the City to establish a shorter term for public safety or substantial land use reasons. Any other permits or approvals issued in connection with any collocation, modification or other change to this wireless facility, which includes without limitation any permits or other approvals deemed-granted or deemed-approved under federal or state law, will not extend this term limit unless expressly provided otherwise in such permit or approval or required under federal or state law.
- VI. Before Permittee submits any applications to the Building Department, Permittee must incorporate this permit, all conditions associated with this permit and the approved photo simulations into the project plans (the "**Approved Plans**"). Permittee must construct, install and operate the wireless facility in strict compliance with the Approved Plans. Any alterations, modifications or other changes to the Approved Plans, whether requested by Permittee or required by other departments or public agencies with jurisdiction over the wireless facility, must be submitted in a written request subject to the Director's prior review and approval, who may refer the request to the original approval authority if the Director finds that the requested

alteration, modification or other change substantially deviates from the Approved Plans or implicates a significant or substantial land-use concern.

- VII. Permittee shall keep the site, which includes without limitation any and all improvements, equipment, structures, access routes, fences and landscape features, in a neat, clean and safe condition in accordance with the Approved Plans and all conditions in this permit. Permittee shall keep the site area free from all litter and debris at all times. Permittee, at no cost to the City, shall remove and remediate any graffiti or other vandalism at the site within 48 hours after Permittee receives notice or otherwise becomes aware that such graffiti or other vandalism occurred.
- VIII. Permittee shall maintain compliance at all times with all federal, state and local statutes, regulations, orders or other rules that carry the force of law ("**Laws**") applicable to Permittee, the subject property, the wireless facility or any use or activities in connection with the use authorized in this permit, which includes without limitation any Laws applicable to human exposure to RF emissions. Permittee expressly acknowledges and agrees that this obligation is intended to be broadly construed and that no other specific requirements in these conditions are intended to reduce, relieve or otherwise lessen Permittee's obligations to maintain compliance with all Laws. In the event that the City fails to timely notice, prompt or enforce compliance with any applicable provision in the Solana Beach Municipal Code, any permit, any permit condition or any applicable law or regulation, the applicant or permittee will not be relieved from its obligation to comply in all respects with all applicable provisions in the Solana Beach Municipal Code, any permit, any permit condition or any applicable law or regulation.
- IX. Permittee shall use all reasonable efforts to avoid any and all undue or unnecessary adverse impacts on nearby properties that may arise from Permittee's or its authorized personnel's construction, installation, operation, modification, maintenance, repair, removal and/or other activities at the site. Permittee shall not perform or cause others to perform any construction, installation, operation, modification, maintenance, repair, removal or other work that involves heavy equipment or machines except during normal construction work hours authorized by the Solana Beach Municipal Code. The restricted work hours in this condition will not prohibit any work required to prevent an actual, immediate harm to property or persons, or any work during an emergency declared by the City. The Director or the Director's designee may issue a stop work order for any activities that violates this condition.

- X. Permittee expressly acknowledges and agrees that the City's officers, officials, staff or other designee may enter onto the site and inspect the improvements and equipment upon reasonable prior notice to Permittee; provided, however, that the City's officers, officials, staff or other designee may, but will not be obligated to, enter onto the site area without prior notice to support, repair, disable or remove any improvements or equipment in emergencies or when such improvements or equipment threatens actual, imminent harm to property or persons. Permittee will be permitted to supervise the City's officers, officials, staff or other designee while any such inspection or emergency access occurs.
- XI. Permittee shall furnish the Director with accurate and up-to-date contact information for a person responsible for the wireless facility, which includes without limitation such person's full name, title, direct telephone number, facsimile number, mailing address and email address. Permittee shall keep such contact information up-to-date at all times and immediately provide the Director with updated contact information in the event that either the responsible person or such person's contact information changes.
- XII. Permittee must maintain complete and accurate copies of all permits and other regulatory approvals issued in connection with the wireless facility, which includes without limitation this approval, the approved plans and photo simulations incorporated into this approval, all conditions associated with this approval and any ministerial permits or approvals issued in connection with this approval. In the event that Permittee does not maintain such records as required in this condition, any ambiguities or uncertainties that would be resolved through an inspection of the missing records will be construed against Permittee. Records may be kept in electronic format.
- XIII. Permittee shall taper the FRP screen walls to the existing building façade on all sides, beginning at the bottom 1/3 of the screen wall.
- XIV. Permittee shall paint and texture the vertical cable riser to match the existing alternating colors on the building.
- XV. Permittee shall paint and texture the FRP screen walls to match the existing color on the building at the height of the screen walls.
- XVI. Permittee shall paint and texture the CMU retaining walls around the equipment enclosure to match the existing walls in the stairwells.
- XVII. All concealment elements and techniques associated with this wireless facility shall be maintained and preserved at all times. Permittee acknowledges that substantial concealment efforts have



been undertaken by both the City and Permittee to mitigate any visible changes to the appearance of the underlying structure caused by the installation of the equipment, which include, without limitation: (1) screening all rooftop and ground-mounted equipment from public view; (2) using materials and finishes that match or mimic the existing structure; (3) installing antennas behind and below existing parapet walls wherever feasible rather than mounting them in "pop-out" screen boxes that would alter the appearance and profile of the roofline and/or facade; (4) tapering pop-out screen boxes placed on the elevator tower to soften the transition between the screen and the underlying structure; (5) mounting antennas in locations and elevations that maintain the appearance of the existing structure and preserve sightlines and scenic views in the vicinity; (6) placing the ground-mounted equipment in an underground enclosure within an existing planter; and (7) replacing and/or supplementing damaged or displaced landscape features. Permittee further acknowledges that the City Council considered all the concealment elements and techniques applied to this wireless facility a critically important factor in its decision to approve this permit, and would not have approved this structure as a suitable location for a wireless facility if it involved lesser concealment elements/techniques or would have resulted in more drastic visual changes to the existing structure and views from surrounding properties.

- XVIII. Permittee shall hire and pay for a licensed arborist to select, plant and maintain a replacement tree in an appropriate location for the species. Only ISA Certified tree workers under the supervision of a licensed arborist shall be used to install the replacement tree. The replacement tree shall be at least a 48" box size, and a type that generally does not exceed 25' in mature overall height, so as not to protrude above the roofline when viewed from vantage points in publicly accessible spaces to the east of the site location. The planting hole shall be at least three times the diameter of the root ball but only as deep as the root ball. The trunk flare at the base of the tree shall be visible after the replacement tree has been planted. Permittee shall, at all times, be responsible to maintain the replacement tree.
- XIX. Permittee shall replace any landscape features damaged or displaced by the construction, installation, operation, maintenance or other work performed by Permittee or at Permittee's direction on or about the site.
- XX. Permittee shall install, and at times maintain in good condition, all equipment, including without limitation antennas, remote radio units, power surge suppressors, GPS antennas, equipment cabinets, power cabinets, battery cabinets and utility panels, fully concealed

from public view within FRP screening or the CMU wall enclosure, as applicable.

- XXI. Permittee shall keep all access points to the main/uppermost rooftop area closed and locked at all times except when active maintenance is being performed on the main/uppermost rooftop or the equipment on the main/uppermost rooftop.
- XXII. Permittee shall install, and at all times maintain in good condition, an "RF Information" or "RF Notice" sign at any main/uppermost rooftop access point(s). Permittee shall install the sign(s) required under this condition so that a person may clearly see and understand the sign before he or she accesses the main/uppermost rooftop area. The sign(s) required under this condition shall be placed in a location where it will be visible whether the door, hatch or other barrier to the main/uppermost rooftop area is in both the open or closed position (e.g., placed on the wall adjacent to the door where it would not be covered by the door in the open position).
- XXIII. Permittee shall install, and at all times maintain in good condition, a polyurethane chain-link barrier in approximately the locations shown in Figure 1 below. Permittee shall also install, and at all times maintain in good condition an "RF Caution" sign on the chain-link barrier in locations where they will be visible to a person approaching the antennas from the main/uppermost rooftop area. In the alternative, Permittee may install alternating floor stripes within the area shown in Figure 1.
- XXIV. Permittee shall keep the access point to the antenna enclosure closed and locked at all times, except when active maintenance is being performed on the antenna enclosure or the equipment within the antenna enclosure.
- XXV. Permittee shall install, and at all times maintain in good condition, an "RF Caution" sign adjacent to the access ladder leading to the antenna enclosure. Permittee shall install the sign required under this condition so that a person may clearly see and understand the sign before he or she accesses the antenna enclosure. The sign required under this condition shall be placed in a location where it will be visible whether the door, hatch or other barrier to the antenna enclosure is in both the open or closed position.
- XXVI. Permittee shall ensure that all signage complies with FCC OET Bulletin 65 or ANSI C95.2 for color, symbol, and content conventions. All such signage shall at all times provide a working local or toll-free telephone number to its network operations center, and such telephone number shall be able to reach a live person who can exert

transmitter power-down control over this site as required by the FCC.

XXVII. AT&T shall power-down the antennas whenever maintenance personnel other than AT&T perform any work on the roof of the building.

XXVIII. AT&T shall install and at all times maintain in good condition an RF Notice at all access points to the roof area. AT&T shall install the RF Notice signs in a location where anyone approaching the roof access point may clearly see the sign.

XXIX. AT&T shall install and at all times maintain in good condition a physical barrier that (1) restricts physical access to the controlled zones in front of the 50\* TN and 240\* TN sectors and (2) substantially conforms to the example provided in Figure 1, of the report dated December 5, 2013. Each barrier shall include an RF Caution sign placed where anyone approaching the barrier will clearly see it before entering the controlled zone.

XXX. AT&T shall ensure that all signs comply with FCC OET Bulletin 65 or ANSI C95.2 for color, symbol, and content conventions. All such signage shall at all times provide a working local or toll-free telephone number to its network operations center, and such telephone number shall be able to reach a live person who can exert transmitter power-down control over this site as required by the FCC.

XXXI. All equipment such as, but not limited to, emergency generators and air conditioners, shall be designed and operated consistent with the City's noise standards.

XXXII. All facilities, related equipment, and landscaping shall be maintained in good condition and free from trash, debris, graffiti, and any form of vandalism. Damaged equipment and damaged, dead or decaying landscaping shall be replaced promptly.

XXXIII. Routine maintenance of equipment located in residential zones or within 100 feet of a residential district shall be conducted only during the hours of 8am and 5pm on weekdays, not including holidays. In other areas, routine maintenance may be conducted within a reasonable length of time to be determined by the City Manager or his designee in the cases of power outages and equipment failure or malfunction. Equipment "change out" and overhaul can occur any time within 30 days notice to the Director of Community Development to allow notice to property owners and residents within 300 feet of the facility.

XXXIV. Maintenance shall not take place on Sundays or holidays.

- XXXV. Security lighting should be kept to a minimum and should only be triggered by a motion detector where practical.
- XXXVI. Within 6 months after the issuance of occupancy and with each time extension or amendment request, the developer/operator shall submit to the Planning Director either a verification that the WCF is categorically excluded from having to determine compliance with the guidelines per 47 CFR 1.1307(b)(1) or a project implementation report that provides cumulative field measurements of RF electromagnetic fields of all antennas installed at the subject site. The report shall quantify the RF emissions and compare the results with the project's preliminary proposal report submitted with the initial project application and the accepted ANSI/IEEE standards. If, on review, the Planning Director finds that the project does not meet ANSI/IEEE standards, the City may take any action necessary, as provided by law, to require compliance including, but not limited to, revoking the CUP.
- XXXVII. Any WCF that is not operated for a continuous period of 90 days will be considered abandoned.
- XXXVIII. Within 90 days of receipt of notice from the City notifying the owner of such abandonment, the WCF owner must remove the facility and restore the site, as much as is reasonable and practical, to its prior condition. If such WCF is not removed within 90 days, the WCF will be considered a nuisance and in addition to any other available remedy, will be subject to abatement under Chapter 6.04 of the SBMC. If there are two or more users of a single WCF, then this provision will not become effective until all users stop using the WCF. The provider or owner must give notice to the City of the intent to discontinue use of any facility before discontinuing the use.
5. ENFORCEMENT: Pursuant to SBMC 17.72.120(B) failure to satisfy any and all of the above-mentioned conditions of approval is subject to the imposition of penalties as set forth in SBMC Chapters 1.1.6 and 1.18 in addition to any applicable revocation proceedings.
6. EXPIRATION: The Conditional Use Permit for WCF's shall be granted for a period not to exceed ten (10) years. Upon a request for either an extension of an amendment of a CUP, the WCF should be reevaluated to assess the impact of the facility on adjacent properties, the record of maintenance and performance with reference to the conditions of approval and consistency with these guidelines. The project will expire on February 14, 2028 or sooner if the WCF is not operated for a continuous period of 90 days in that case the WCF will be considered abandoned.

7. INDEMNIFICATION AGREEMENT: The Applicant shall defend, indemnify, and hold harmless the City, its agents, officers, and employees from any and all claims, actions, proceedings, damages, judgments, or costs, including attorney's fees, against the City or its agents, officers, or employees, relating to the issuance of this permit including, but not limited to, any action to attack, set aside, void, challenge, or annul this development approval and any environmental document or decision. The City will promptly notify Applicant of any claim, action, or proceeding. The City may elect to conduct its own defense, participate in its own defense, or obtain independent legal counsel in defense of any claim related to this indemnification. In the event of such election, Applicant shall pay all of the costs related thereto, including without limitation reasonable attorney's fees and costs. In the event of a disagreement between the City and Applicant regarding litigation issues, the City shall have the authority to control the litigation and make litigation related decisions, including, but not limited to, settlement or other disposition of the matter. However, the Applicant shall not be required to pay or perform any settlement unless such settlement is approved by Applicant.
8. NOTICE TO APPLICANT: Pursuant to Government Code Section 66020, you are hereby notified that the 90-day period to protest the imposition of the fees, dedications, reservations or other exactions described in this resolution commences on the effective date of this resolution. To protest the imposition of any fee, dedications, reservations or other exactions described in this resolution you must comply with the provisions of Government Code Section 66020. Generally the resolution is effective upon expiration of the tenth day following the date of adoption of this resolution, unless the resolution is appealed or called for review as provided in the Solana Beach Zoning Ordinance.

PASSED AND ADOPTED at a regular meeting of the City Council of the City of Solana Beach, California, held on the 14<sup>th</sup> day of February, 2018, by the following vote:

AYES: Councilmembers –

NOES: Councilmembers –

ABSENT: Councilmembers –

ABSTAIN: Councilmembers –

\_\_\_\_\_  
GINGER MARSHALL, Mayor

APPROVED AS TO FORM:

ATTEST:

\_\_\_\_\_  
JOHANNA N. CANLAS, City Attorney

\_\_\_\_\_  
ANGELA IVEY, City Clerk



# STAFF REPORT CITY OF SOLANA BEACH

**TO:** Honorable Mayor and City Councilmembers  
**FROM:** Gregory Wade, City Manager  
**MEETING DATE:** January 10, 2018  
**ORIGINATING DEPT:** Community Development Department  
**SUBJECT:** **Public Hearing: CUP/DRP/SDP for a New Wireless Communications Facility at 201 Lomas Santa Fe (Case # 17-17-15 Applicant: AT&T Mobility) Resolution 2017-166**

---

## BACKGROUND:

The Applicant, AT&T Mobility (hereinafter referred to as "Applicant"), is requesting the approval of a Conditional Use Permit (CUP), Development Review Permit (DRP) and Structure Development Permit (SDP) to construct a new Wireless Communication Facility (WCF) on top of an existing commercial office building at 201 Lomas Santa Fe. The Applicant is proposing to increase the height of an existing elevator tower in order to construct a new antenna enclosure that would conceal 12 panel antennas, 32 Remote Radio Units (RRU's), six surge suppressors, and two GPS antennas behind fiber reinforced plastic screening colored and textured to match the existing building. A new ground level equipment enclosure would be installed that would contain four stack-mounted radio equipment cabinets, one power cabinet, one battery cabinet and telephone and electric utility panels on a concrete slab foundation. The enclosure would be located in the location that is currently a landscape planter adjacent to the building entrance. The antenna enclosure would increase the width and depth of the top 12 feet of the existing tower by three feet and the height by four feet. The highest point of the proposed antennas will be 41.5 feet above the existing grade and 153.2 feet above the existing grade. Solana Beach Municipal Code (SBMC) section 17.60.120(G)(1) indicates that all WCF's are subject to a CUP and must comply with City Council Policy 21. A DRP is required for "any new commercial development or construction (including any structural addition to existing development) located within any commercial zone which results in an increase of more than 500 feet of gross floor area or to the overall building envelope." The proposed addition would exceed 16 feet in height from the existing grade and, therefore, requires a Structure Development Permit (SDP).

This item is before the City Council to approve, conditionally approve or deny the Applicant's request for a CUP, DRP, and SDP for a new WCF at 201 Lomas Santa Fe, Solana Beach, as contained in Resolution 2017-167 (Attachment 1).

CITY COUNCIL ACTION:

---

---

---

## **DISCUSSION:**

This project was originally heard at the December 13, 2017 City Council meeting. The original Staff Report has been provided in Attachment 2. At that meeting, the proposed project and several alternative sites were discussed. The Applicant indicated that an existing site on Lomas Santa Fe is being decommissioned and because of that, there would be a significant gap in coverage. By constructing the proposed site at 201 Lomas Santa Fe, that significant gap would be addressed. The federal Telecommunications Act of 1996 indicates that local governments cannot prohibit or effectively prohibit personal wireless communication services. If an Applicant demonstrates that there is a "significant gap" in their service coverage and the proposed site constitutes the "least intrusive means" to mitigate that significant gap, the Ninth Circuit holds that a single permit denial violates the Telecom Act.

After receiving public testimony and evidence regarding the project at the Council meeting, the Council indicated that they were not able to make the finding that the proposed project design constitutes the "least intrusive means" in addressing the gap in coverage. The Council requested that the Applicant provide additional analysis for the project site based on aesthetic concerns. Specifically, the Council requested information regarding the feasibility of separating the antenna sectors and install several radio frequency (RF) transparent screening boxes on different sides of the structure at lower heights. The Council also requested to see a sample of what the proposed RF transparent screening material would look like to verify that it would in fact match the existing exterior of the structure in color and texture. The Applicant agreed to provide the requested information. The council voted 5/0 to continue the project to a date certain of January 10, 2018.

To address the concerns expressed by the public and the City Council at the December 13, 2017 meeting, the Applicant submitted an alternative project design to address the aesthetic concerns on January 3, 2018 which have been provided in Attachment 3.

The project alternative incorporates the following changes from the original design:

- The eastern facing antenna sector would be moved to the northeastern corner of the third story of the building. The antennas would be attached to the outer façade of the building and would be screened with a 1'-6" X 9' fiber reinforced plastic (FRP) box painted and textured to match the existing structure that would project approximately two feet taller than the existing parapet.
- The north, south and western facing antenna sectors would remain at the top of the existing elevator tower in a 9'-4" X 13'-5" antenna enclosure, however, the height of the elevator tower would be raised two feet instead of four feet in the original project design. The proposed height of the elevator tower would be 39'-7" above the adjacent existing grade.
- An additional 14'-10" X 10' enclosure would be constructed east of the elevator tower antenna enclosure that would increase the height of the existing roof of the

structure by two feet. This enclosure would conceal 12 of the Remote Radio Units (RRU's) and two of the DC Surge Suppressors.

- The design of the ground level equipment enclosure would remain the same with the project alternative.

Two draft Resolutions have been provided based upon the original project design presented at the December 13, 3017 City Council meeting and the project alternative discussed in this report. They include the applicable SBMC sections in italicized text. If the Council can make the required findings to approve the project the Council should provide direction as to which project alternative they are conditionally approving in the resolution. The City Council can also provide direction to reflect the findings and conditions it deems appropriate as a part of the Public Hearing process.

#### **CEQA COMPLIANCE STATEMENT:**

The project is exempt from the California Environmental Quality Act (CEQA) pursuant to Section 15301 of the State CEQA Guidelines.

**FISCAL IMPACT:** N/A

**WORK PLAN:** N/A

#### **OPTIONS:**

- Approve Staff recommendation adopting the attached Resolution 2017-167.
- Approve Staff recommendation subject to additional specific conditions necessary for the City Council to make all required findings for the approval of a DRP.
- Deny the project if all required findings for the DRP cannot be made.

#### **DEPARTMENT RECOMMENDATION:**

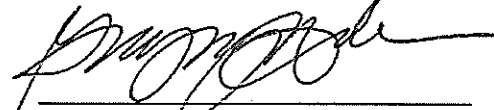
The proposed project meets the minimum zoning requirements under the SBMC, may be found to be consistent with the General Plan and may be found, as conditioned, to meet the discretionary findings required as discussed in this report to approve a DRP. Therefore, Staff recommends that the City Council:

1. Conduct the Public Hearing: Open the Public Hearing, Report Council Disclosures, Receive Public Testimony, and Close the Public Hearing.
2. Find the project exempt from the California Environmental Quality Act pursuant to Section 15301 of the State CEQA Guidelines; and
3. Adopt Resolution 2017-167 conditionally approving a CUP/DRP/SDP for a new WCF and associated equipment located on the roof of an existing commercial office building at 201 Lomas Santa Fe, Solana Beach and provide direction to Staff as to which project alternative the Council is approving.



**CITY MANAGER'S RECOMMENDATION:**

Approve Department Recommendation.

  
\_\_\_\_\_  
Gregory Wade, City Manager

Attachments:

1. Resolution 2017-167 and alternate project Resolution 2017-167
2. December 13, 2017 Staff Report and Attachments
3. Alternative Project Design Plans

**RESOLUTION NO. 2017-167**

**A RESOLUTION OF THE CITY COUNCIL OF THE CITY OF SOLANA BEACH, CALIFORNIA, CONDITIONALLY APPROVING A CONDITIONAL USE PERMIT, DEVELOPMENT REVIEW PERMIT AND STRUCTURE DEVELOPMENT PERMIT FOR A NEW WIRELESS COMMUNICATIONS FACILITY LOCATED ON THE EXISTING COMMERCIAL STRUCTURE AT 201 LOMAS SANTA FE, SOLANA BEACH**

**APPLICANT: AT&T Mobility**  
**CASE NO.: 17-17-15 CUP/DRP/SDP**

**WHEREAS**, AT&T Mobility (hereinafter referred to as "Applicant") has submitted an application for a Conditional Use Permit (CUP), Development Review Permit (DRP) and Structure Development Permit (SDP) pursuant to Title 17 (Zoning) of the Solana Beach Municipal Code (SBMC) and City Council Policy 21; and

**WHEREAS**, the Applicant is proposing a new WCF location in order to replace a WCF being removed from the commercial structure at 505 Lomas Santa Fe; and

**WHEREAS**, at the hearing on December 13, 2017, the City Council received and considered evidence concerning the proposed application; and

**WHEREAS**, on December 13, 2017, the public hearing was conducted pursuant to the provisions of Solana Beach Municipal Code Section 17.72.030; and

**WHEREAS**, the City Council of the City of Solana Beach continued the project to a date certain, January 10, 2018, so that the Applicant could address concerns raised at the December 13, 2018 Council meeting by providing additional analysis on a project alternative onsite; and

**WHEREAS**, at the public hearing on January 10, 2018, the City Council received and considered evidence concerning the proposed application; and

**WHEREAS**, on January 10, 2018, the public hearing was conducted pursuant to the provisions of Solana Beach Municipal Code Section 17.72.030; and

**WHEREAS**, the City Council of the City of Solana Beach found the application request exempt from the California Environmental Quality Act pursuant to Section 15301 of the State CEQA Guidelines; and

**WHEREAS**, this decision is based upon the evidence presented at the hearings, and any information the City Council gathered by viewing the site and the area as disclosed at the hearing.

**NOW THEREFORE**, the City Council of the City of Solana Beach, California, does resolve as follows:

1. That the foregoing recitations are true and correct.

2. That the request for a CUP/DRP/SDP to construct a new WCF located on the top of the existing elevator tower of an existing commercial office building and a ground level equipment enclosure at 201 Lomas Santa Fe is conditionally approved based upon the following Findings and subject to the following Conditions:

### 3. FINDINGS

- A. In accordance with Section 17.68.010 (Conditional Use Permit) of the City of Solana Beach Municipal Code, the City Council finds the following:

- I. Before granting a Conditional Use Permit, the Planning Director or City Council shall make all of the following findings:*

- a. The proposed use is in accord with the General Plan, the general intent of this title, and the purposes of the zone in which the site is located.*

General Plan Consistency: The proposed project, as conditioned, is consistent with the City's General Plan designation of Office/Professional which provides for professional office and general office in addition to other compatible uses such as religious facilities, educational institutions, parks and recreation facilities, and public utilities. Further, the proposed development is consistent with the objectives of the General Plan as it encourages the development of commercial land uses which strengthen the City's economic base and offer a range of commercial enterprises to meet the needs of the residents and visitors.

Zoning Ordinance Consistency: The proposed project is consistent with all applicable requirements of the Zoning Ordinance (Title 17), which delineates Permitted Uses and Structures (SBMC Section 17.24.020 and 17.24.030), and provides for uses which allow an Applicant to locate a commercial transmission and receiving antenna on a property within the OP Zone. Further, the proposed project adheres to all property development regulations established for the OP Zone and cited by the SBMC Section 17.24.030.

The design of the proposed project is consistent with the provisions for minimum yard dimensions (i.e. setbacks) and maximum building height. The project also complies with City Council 21 regulations as required by SBMC Section 17.60.120 for height, setbacks, proximity to residential uses, the uses of surrounding properties, quality and compatibility of design and screening, and impacts to public views and visual quality of the surrounding areas.

- b. The proposed use, together with the conditions applicable thereto, will not be detrimental to the public health, safety, or welfare, or materially injurious to properties or improvements in the vicinity.*

The Applicant has submitted an updated third party Radio Frequency Safety Survey Report Prediction prepared by Waterford Compliance dated March 30, 2017. This report indicates that there would be a controlled access zone extending approximately 34 feet horizontally from the face of the antennas at roughly the height of the antennas at all four antenna sectors. The existence of the controlled access zone does not mean that the project violates the FCC rules; rather, it indicates that the carrier must affirmatively restrict public access to that area so that members of the general population (including trespassers) cannot unknowingly enter and be exposed to radio emissions in excess of those allowed by the FCC. Therefore, the project will not be detrimental to the public health, safety or welfare, or materially injurious to properties or improvement in the vicinity as determined by the FCC based on its exposure limits.

- c. That the proposed use complies with each of the applicable provision of the zoning ordinance, unless a variance is granted pursuant to SBMC 17.68.020*

The proposed project complies with the property development regulations of SBMC 17.24.030, as well as the Wireless Communications Facilities guidelines of City Council Policy 21, which are required according to SBMC Section 17.60.120 for maximum height, setbacks, proximity to residential properties, impacts on public views and visual quality of the surrounding area.

- II. If the Conditional Use Permit is for the purpose of permitting an expansion, restoration or extension of a nonconforming use or structure then only the findings of Chapter 17.16 SBMC must be made.*

The proposed project is not for the purpose of permitting an expansion, restoration or extension of a nonconforming use or structure.

- B. In accordance with Section 17.68.040 (Development Review Permit) of the City of Solana Beach Municipal Code, the City Council finds the following:

- I. The proposed project is consistent with the General Plan and all applicable requirements of SBMC Title 17 (Zoning Ordinance), including special regulations, overlay zones, and specific plans.*

General Plan Consistency: The proposed project, as conditioned, is consistent with the City's General Plan designation of Office/Professional which provides for professional office and general office in addition to other compatible uses such as religious facilities, educational institutions, parks and recreation facilities, and public utilities. Further, the proposed development is consistent with the objectives of the General Plan as it encourages the development of commercial land uses which strengthen the City's economic base and offer a range of commercial enterprises to meet the needs of the residents and visitors.

Zoning Ordinance Consistency: The proposed project is consistent with all applicable requirements of the Zoning Ordinance (Title 17), which delineates Permitted Uses and Structures (SBMC Section 17.24.020 and 17.24.030), and provides for uses which allow an Applicant to locate a commercial transmission and receiving antenna on a property within the OP Zone. Further, the proposed project adheres to all property development regulations established for the OP Zone and cited by the SBMC Section 17.24.030.

The design of the proposed project is consistent with the provisions for minimum yard dimensions (i.e. setbacks) and maximum building height. The project also complies with City Council 21 regulations as required by SBMC Section 17.60.120 for height, setbacks, proximity to residential uses, the uses of surrounding properties, quality and compatibility of design and screening, and impacts to public views and visual quality of the surrounding areas.

II. *The proposed development complies with the following development review criteria set forth in Solana Beach Municipal Code Section 17.68.040(F):*

a. *Relationship with Adjacent Land Uses: The development shall be designed in a manner compatible with and complementary to existing development in the immediate vicinity of the project site and the surrounding neighborhood. The development as proposed shall also be compatible in scale, apparent bulk, and massing with such existing development in the surrounding neighborhood. Site planning on or near the perimeter of the development shall give consideration to the protection of surrounding areas from potential adverse effects.*

The property is located within the OP Zone and the SAOZ. Properties to the west are located within the Special Commercial (SC) Zone and developed with the Minute Shop liquor store, to the

north are in the Light Commercial Zone and are developed with a two story mixed retail and office building. Properties to the east are located within the Low Medium Residential (LMR) Zone and to the south properties are within the Low Residential (LR) Zone. The residentially zoned lots are developed with a mix of one and two story, single family residences. The project site is currently developed with a multi-level office building with a parking lot located towards the southern property line. The project, as designed, is consistent with the specific development standards of the OP Zone as described in SBMC Sections 17.24.010 and 17.12.020. The proposed development could be found to be consistent with the objectives of the General Plan as it encourages the development of commercial land uses which strengthen the City's economic base and offer a range of commercial enterprises to meet the needs of the residents and visitors.

The property is located within the SAOZ, however, as mentioned previously can be found exempt from the specific requirements of the overlay zone because it is a minor modification. As a condition of project approval, the Applicant would be required to obtain a Coastal Development Permit, Waiver or Exemption from the California Coastal Commission prior to the issuance of a Building Permit.

- b. *Building and Structure Placement: Buildings and structures shall be sited and designed to minimize adverse impacts on the surrounding properties and designed in a manner which visually and functionally enhance their intended use and complement existing site topography. Multi-family residential buildings shall be sited to avoid crowding and to allow for a functional use of the space between buildings.*

The proposed WCF addition would increase the height, depth, and width of the existing elevator enclosure in order to provide space to install three antennas in four sectors and associated equipment. The soil and vegetation will be removed from an existing planter area at the ground level in order to provide a below grade equipment enclosure.

The OP Zone has required setbacks of 15 feet for the front, 15 feet for a street side and 15 feet for the rear when it is abutting residentially zoned properties. As designed the proposed equipment enclosure would be setback approximately 70 feet from Lomas Santa Fe and the antenna enclosure would be setback approximately 90 feet. The maximum building height for the OP zone is 45 feet as measured from the lower of the existing or proposed grade, the tallest point of the proposed antenna enclosure would be approximately 41.5 feet above the existing grade directly adjacent to the enclosure.

- c. *Landscaping: The removal of significant native vegetation shall be minimized. Replacement vegetation and landscaping shall be compatible with the vegetation of the surrounding area. To the maximum extent practicable, landscaping and plantings shall be used to screen parking areas, storage areas, access roads, and other service uses of the site. Trees and other large plantings shall not obstruct significant views when installed or at maturity. Drought tolerant plant materials and water conserving irrigation systems shall be incorporated into all landscaping plans.*

The project is not subject to the water efficient landscaping regulations of SBMC Chapter 17.56. According to SBMC Section 17.56.040, the regulations apply to modified irrigated landscaped areas that exceed 500 square feet. As designed, approximately 158 square feet of landscaped area will be removed in order to construct the equipment enclosure. The Applicant would remove a portion of the existing retaining wall that surrounds an existing landscape planter and excavate the soil and remove the existing vegetation in order to pour a concrete slab. In addition, an existing diseased tree adjacent to the proposed equipment enclosure would be removed and replaced with the proposed project.

- d. *Roads, Pedestrian Walkways, Parking and Storage Areas: Any development involving more than one building or structure shall provide common access roads and pedestrian walkways. Parking and outside storage areas, where permitted, shall be screened from view, to the extent feasible, by existing topography, by the placement of buildings and structures, or by landscaping and plantings.*

No additional parking is required for an unmanned WCF.

- e. *Grading: To the extent feasible, natural topography and scenic features of the site shall be retained and incorporated into the proposed development. Any grading or earth-moving operations in connection with the proposed development shall be planned and executed so as to blend with the existing terrain both on and adjacent to the site. Existing exposed or disturbed slopes shall be landscaped with native or naturalized non-native vegetation and existing erosion problems shall be corrected.*

The proposed grading quantities include 29.4 cubic yards for the excavation to be exported off-site in order to remove the existing plant and soil from the planter box and construct a below grade equipment enclosure for the proposed WCF.

- f. *Lighting: Light fixtures for walkways, parking areas, driveways, and other facilities shall be provided in sufficient number and at proper locations to assure safe and convenient nighttime use. All light fixtures shall be appropriately shielded so that no light or glare is transmitted or reflected in such concentrated quantities or intensities as to be detrimental to the surrounding areas per SBMC 17.60.060 (Exterior Lighting Regulations).*

A condition of project approval includes that all new exterior lighting fixtures comply with the City-Wide Lighting Regulations of the Zoning Ordinance (SBMC 17.60.060). All light fixtures shall be shielded so that no light or glare is transmitted or reflected in such concentrated quantities or intensities as to be detrimental to the surrounding area.

- g. *Usable Open Space: Recreational facilities proposed within required usable open space shall be located and designed to maintain essential open space values.*

The project consists of the construction of a new WCF on an existing office building, therefore, usable open space and recreational facilities are neither proposed nor required according to SBMC Section 17.20.040.

- III. *All required permits and approvals issued by the City, including variances, conditional use permits, comprehensive sign plans, and coastal development permits, have been obtained prior to or concurrently with the development review permit.*

All required permits are being processed concurrently with the CUP. As a condition of project approval, the Applicant shall obtain approval from the CCC prior to issuance of Building Permits.

- IV. *If the development project also requires a permit or approval to be issued by a state or federal agency, the city council may conditionally approve the development review permit upon the applicant obtaining the required permit or approval from the other agency.*

As a condition of project approval, the Applicant will be required to obtain approval from the California Coastal Commission (CCC) prior to the issuance of Building Permits.

- C. In accordance with Section 17.63.040 (Structure Development Permit) of the Solana Beach Municipal Code, the City Council finds the following:
- I. Notices were mailed to all property owners and residents within 300 feet of the property and the deadline to file for View Assessment was



November 22, 2017. No applications for View Assessment were received.

Therefore, the requirements for the approval of a SDP have been met. The SDP will be issued administratively with the CUP and DRP.

As a condition of project approval, once construction has begun, the Applicant will be required to submit a height certification prior to the framing inspection. The Height Certification will be signed by a licensed land surveyor and will verify that the framing materials and the proposed roofing materials will not exceed the maximum building height of 41.5 feet from the existing grade or 153.2 feet above MSL as approved by the SDP.

#### 4. CONDITIONS

Prior to use or development of the property in reliance on this permit, the Applicant shall provide for and adhere to the following conditions:

##### A. Community Development Department Conditions:

- I. Building Permit plans must be in substantial conformance with the plans presented to the City Council on January 10, 2018, located in the project file with a submittal date of December XX, 2017.
- II. The Applicant shall obtain required California Coastal Commission (CCC) approval of a Coastal Development Permit, Waiver or Exemption as determined necessary by the CCC, prior to the issuance of a building permit.
- III. Any new exterior lighting fixtures shall be in conformance with the City-Wide Lighting Regulations of SBMC 17.60.060.
- IV. All light fixtures shall be appropriately shielded so that no light or glare is transmitted or reflected in such concentrated quantities or intensities that render them detrimental to the surrounding area.
- V. This permit will automatically expire 10 years and one day from its issuance, except when California Government Code § 65964(b), as may be amended or superseded in the future, authorizes the City to establish a shorter term for public safety or substantial land use reasons. Any other permits or approvals issued in connection with any collocation, modification or other change to this wireless facility, which includes without limitation any permits or other approvals deemed-granted or deemed-approved under federal or state law, will not extend this term limit unless expressly provided otherwise in such permit or approval or required under federal or state law.

- VI. Before Permittee submits any applications to the Building Department, Permittee must incorporate this permit, all conditions associated with this permit and the approved photo simulations into the project plans (the "**Approved Plans**"). Permittee must construct, install and operate the wireless facility in strict compliance with the Approved Plans. Any alterations, modifications or other changes to the Approved Plans, whether requested by Permittee or required by other departments or public agencies with jurisdiction over the wireless facility, must be submitted in a written request subject to the Director's prior review and approval, who may refer the request to the original approval authority if the Director finds that the requested alteration, modification or other change substantially deviates from the Approved Plans or implicates a significant or substantial land-use concern.
- VII. Permittee shall keep the site, which includes without limitation any and all improvements, equipment, structures, access routes, fences and landscape features, in a neat, clean and safe condition in accordance with the Approved Plans and all conditions in this permit. Permittee shall keep the site area free from all litter and debris at all times. Permittee, at no cost to the City, shall remove and remediate any graffiti or other vandalism at the site within 48 hours after Permittee receives notice or otherwise becomes aware that such graffiti or other vandalism occurred.
- VIII. Permittee shall maintain compliance at all times with all federal, state and local statutes, regulations, orders or other rules that carry the force of law ("**Laws**") applicable to Permittee, the subject property, the wireless facility or any use or activities in connection with the use authorized in this permit, which includes without limitation any Laws applicable to human exposure to RF emissions. Permittee expressly acknowledges and agrees that this obligation is intended to be broadly construed and that no other specific requirements in these conditions are intended to reduce, relieve or otherwise lessen Permittee's obligations to maintain compliance with all Laws. In the event that the City fails to timely notice, prompt or enforce compliance with any applicable provision in the Solana Beach Municipal Code, any permit, any permit condition or any applicable law or regulation, the applicant or permittee will not be relieved from its obligation to comply in all respects with all applicable provisions in the Solana Beach Municipal Code, any permit, any permit condition or any applicable law or regulation.
- IX. Permittee shall use all reasonable efforts to avoid any and all undue or unnecessary adverse impacts on nearby properties that may arise from Permittee's or its authorized personnel's construction, installation, operation, modification, maintenance, repair, removal

and/or other activities at the site. Permittee shall not perform or cause others to perform any construction, installation, operation, modification, maintenance, repair, removal or other work that involves heavy equipment or machines except during normal construction work hours authorized by the Solana Beach Municipal Code. The restricted work hours in this condition will not prohibit any work required to prevent an actual, immediate harm to property or persons, or any work during an emergency declared by the City. The Director or the Director's designee may issue a stop work order for any activities that violates this condition.

- X. Permittee expressly acknowledges and agrees that the City's officers, officials, staff or other designee may enter onto the site and inspect the improvements and equipment upon reasonable prior notice to Permittee; provided, however, that the City's officers, officials, staff or other designee may, but will not be obligated to, enter onto the site area without prior notice to support, repair, disable or remove any improvements or equipment in emergencies or when such improvements or equipment threatens actual, imminent harm to property or persons. Permittee will be permitted to supervise the City's officers, officials, staff or other designee while any such inspection or emergency access occurs.
- XI. Permittee shall furnish the Director with accurate and up-to-date contact information for a person responsible for the wireless facility, which includes without limitation such person's full name, title, direct telephone number, facsimile number, mailing address and email address. Permittee shall keep such contact information up-to-date at all times and immediately provide the Director with updated contact information in the event that either the responsible person or such person's contact information changes.
- XII. Permittee must maintain complete and accurate copies of all permits and other regulatory approvals issued in connection with the wireless facility, which includes without limitation this approval, the approved plans and photo simulations incorporated into this approval, all conditions associated with this approval and any ministerial permits or approvals issued in connection with this approval. In the event that Permittee does not maintain such records as required in this condition, any ambiguities or uncertainties that would be resolved through an inspection of the missing records will be construed against Permittee. Records may be kept in electronic format.
- XIII. Permittee shall taper the FRP screen walls to the existing building façade on all sides, beginning at the bottom 1/3 of the screen wall.
- XIV. Permittee shall paint and texture the vertical cable riser to match the

existing alternating colors on the building.

- XV. Permittee shall paint and texture the FRP screen walls to match the existing color on the building at the height of the screen walls.
- XVI. Permittee shall paint and texture the CMU retaining walls around the equipment enclosure to match the existing walls in the stairwells.
- XVII. Permittee shall hire and pay for a licensed arborist to select, plant and maintain a replacement tree in an appropriate location for the species. Only ISA Certified tree workers under the supervision of a licensed arborist shall be used to install the replacement tree. The replacement tree shall be at least a 48" box size, and a type that generally does not exceed 25' in mature overall height, so as not to protrude above the roofline when viewed from vantage points in publicly accessible spaces to the east of the site location. The planting hole shall be at least three times the diameter of the root ball but only as deep as the root ball. The trunk flare at the base of the tree shall be visible after the replacement tree has been planted. Permittee shall, at all times, be responsible to maintain the replacement tree.
- XVIII. Permittee shall replace any landscape features damaged or displaced by the construction, installation, operation, maintenance or other work performed by Permittee or at Permittee's direction on or about the site.
- XIX. Permittee shall install, and at times maintain in good condition, all equipment, including without limitation antennas, remote radio units, power surge suppressors, GPS antennas, equipment cabinets, power cabinets, battery cabinets and utility panels, fully concealed from public view within FRP screening or the CMU wall enclosure, as applicable.
- XX. Permittee shall keep all access points to the main/uppermost rooftop area closed and locked at all times except when active maintenance is being performed on the main/uppermost rooftop or the equipment on the main/uppermost rooftop.
- XXI. Permittee shall install, and at all times maintain in good condition, an "RF Information" or "RF Notice" sign at any main/uppermost rooftop access point(s). Permittee shall install the sign(s) required under this condition so that a person may clearly see and understand the sign before he or she accesses the main/uppermost rooftop area. The sign(s) required under this condition shall be placed in a location where it will be visible whether the door, hatch or other barrier to the main/uppermost rooftop area is in both the open or closed position

(e.g., placed on the wall adjacent to the door where it would not be covered by the door in the open position).

- XXII. Permittee shall install, and at all times maintain in good condition, a polyurethane chain-link barrier in approximately the locations shown in Figure 1 below. Permittee shall also install, and at all times maintain in good condition an "RF Caution" sign on the chain-link barrier in locations where they will be visible to a person approaching the antennas from the main/uppermost rooftop area. In the alternative, Permittee may install alternating floor stripes within the area shown in Figure 1.
- XXIII. Permittee shall keep the access point to the antenna enclosure closed and locked at all times, except when active maintenance is being performed on the antenna enclosure or the equipment within the antenna enclosure.
- XXIV. Permittee shall install, and at all times maintain in good condition, an "RF Caution" sign adjacent to the access ladder leading to the antenna enclosure. Permittee shall install the sign required under this condition so that a person may clearly see and understand the sign before he or she accesses the antenna enclosure. The sign required under this condition shall be placed in a location where it will be visible whether the door, hatch or other barrier to the antenna enclosure is in both the open or closed position.
- XXV. Permittee shall ensure that all signage complies with FCC OET Bulletin 65 or ANSI C95.2 for color, symbol, and content conventions. All such signage shall at all times provide a working local or toll-free telephone number to its network operations center, and such telephone number shall be able to reach a live person who can exert transmitter power-down control over this site as required by the FCC.
- XXVI. AT&T shall power-down the antennas whenever maintenance personnel other than AT&T perform any work on the roof of the building.
- XXVII. AT&T shall install and at all times maintain in good condition an RF Notice at all access points to the roof area. AT&T shall install the RF Notice signs in a location where anyone approaching the roof access point may clearly see the sign.
- XXVIII. AT&T shall install and at all times maintain in good condition a physical barrier that (1) restricts physical access to the controlled zones in front of the 50\* TN and 240\* TN sectors and (2) substantially conforms to the example provided in Figure 1, of the report dated December 5, 2013. Each barrier shall include an RF

Caution sign placed where anyone approaching the barrier will clearly see it before entering the controlled zone.

- XXIX. AT&T shall ensure that all signs comply with FCC OET Bulletin 65 or ANSI C95.2 for color, symbol, and content conventions. All such signage shall at all times provide a working local or toll-free telephone number to its network operations center, and such telephone number shall be able to reach a live person who can exert transmitter power-down control over this site as required by the FCC.
- XXX. All equipment such as, but not limited to, emergency generators and air conditioners, shall be designed and operated consistent with the City's noise standards.
- XXXI. All facilities, related equipment, and landscaping shall be maintained in good condition and free from trash, debris, graffiti, and any form of vandalism. Damaged equipment and damaged, dead or decaying landscaping shall be replaced promptly.
- XXXII. Routine maintenance of equipment located in residential zones or within 100 feet of a residential district shall be conducted only during the hours of 8am and 5pm on weekdays, not including holidays. In other areas, routine maintenance may be conducted within a reasonable length of time to be determined by the City Manager or his designee in the cases of power outages and equipment failure or malfunction. Equipment "change out" and overhaul can occur any time within 30 days notice to the Director of Community Development to allow notice to property owners and residents within 300 feet of the facility.
- XXXIII. Maintenance shall not take place on Sundays or holidays.
- XXXIV. Security lighting should be kept to a minimum and should only be triggered by a motion detector where practical.
- XXXV. Within 6 months after the issuance of occupancy and with each time extension or amendment request, the developer/operator shall submit to the Planning Director either a verification that the WCF is categorically excluded from having to determine compliance with the guidelines per 47 CFR 1.1307(b)(1) or a project implementation report that provides cumulative field measurements of RF electromagnetic fields of all antennas installed at the subject site. The report shall quantify the RF emissions and compare the results with the projects preliminary proposal report submitted with the initial project application and the accepted ANSI/IEEE standards. If, on review, the Planning Director finds that the project does not meet ANSI/IEEE standards, the City may take any action necessary, as

provided by law, to require compliance including, but not limited to, revoking the CUP.

XXXVI. Any WCF that is not operated for a continuous period of 90 days will be considered abandoned.

XXXVII. Within 90 days of receipt of notice from the City notifying the owner of such abandonment, the WCF owner must remove the facility and restore the site, as much as is reasonable and practical, to its prior condition. If such WCF is not removed within 90 days, the WCF will be considered a nuisance and in addition to any other available remedy, will be subject to abatement under Chapter 6.04 of the SBMC. If there are two or more users of a single WCF, then this provision will not become effective until all users stop using the WCF. The provider or owner must give notice to the City of the intent to discontinue use of any facility before discontinuing the use.

5. ENFORCEMENT: Pursuant to SBMC 17.72.120(B) failure to satisfy any and all of the above-mentioned conditions of approval is subject to the imposition of penalties as set forth in SBMC Chapters 1.1.6 and 1.18 in addition to any applicable revocation proceedings.
6. EXPIRATION: The Conditional Use Permit for WCF's shall be granted for a period not to exceed ten (10) years. Upon a request for either an extension of an amendment of a CUP, the WCF should be reevaluated to assess the impact of the facility on adjacent properties, the record of maintenance and performance with reference to the conditions of approval and consistency with these guidelines. The project will expire on December 13, 2027 or sooner if the WCF is not operated for a continuous period of 90 days in that case the WCF will be considered abandoned.
7. INDEMNIFICATION AGREEMENT: The Applicant shall defend, indemnify, and hold harmless the City, its agents, officers, and employees from any and all claims, actions, proceedings, damages, judgments, or costs, including attorney's fees, against the City or its agents, officers, or employees, relating to the issuance of this permit including, but not limited to, any action to attack, set aside, void, challenge, or annul this development approval and any environmental document or decision. The City will promptly notify Applicant of any claim, action, or proceeding. The City may elect to conduct its own defense, participate in its own defense, or obtain independent legal counsel in defense of any claim related to this indemnification. In the event of such election, Applicant shall pay all of the costs related thereto, including without limitation reasonable attorney's fees and costs. In the event of a disagreement between the City and Applicant regarding litigation issues, the City shall have the authority to control the litigation and make litigation related decisions, including, but not limited to, settlement or other disposition of the matter. However, the Applicant shall not be required to pay or perform any settlement unless such settlement is approved by

Applicant.

8. NOTICE TO APPLICANT: Pursuant to Government Code Section 66020, you are hereby notified that the 90-day period to protest the imposition of the fees, dedications, reservations or other exactions described in this resolution commences on the effective date of this resolution. To protest the imposition of any fee, dedications, reservations or other exactions described in this resolution you must comply with the provisions of Government Code Section 66020. Generally the resolution is effective upon expiration of the tenth day following the date of adoption of this resolution, unless the resolution is appealed or called for review as provided in the Solana Beach Zoning Ordinance.

PASSED AND ADOPTED at a regular meeting of the City Council of the City of Solana Beach, California, held on the 10<sup>th</sup> day of January, 2018, by the following vote:

AYES: Councilmembers –

NOES: Councilmembers –

ABSENT: Councilmembers –

ABSTAIN: Councilmembers –

\_\_\_\_\_  
GINGER MARSHALL, Mayor

APPROVED AS TO FORM:

ATTEST:

\_\_\_\_\_  
JOHANNA N. CANLAS, City Attorney

\_\_\_\_\_  
ANGELA IVEY, City Clerk



**RESOLUTION NO. 2017-167**

**A RESOLUTION OF THE CITY COUNCIL OF THE CITY OF SOLANA BEACH, CALIFORNIA, CONDITIONALLY APPROVING A CONDITIONAL USE PERMIT, DEVELOPMENT REVIEW PERMIT AND STRUCTURE DEVELOPMENT PERMIT FOR A NEW WIRELESS COMMUNICATIONS FACILITY LOCATED ON THE EXISTING COMMERCIAL STRUCTURE AT 201 LOMAS SANTA FE, SOLANA BEACH**

**APPLICANT: AT&T Mobility**  
**CASE NO.: 17-17-15 CUP/DRP/SDP**

**WHEREAS**, AT&T Mobility (hereinafter referred to as "Applicant") has submitted an application for a Conditional Use Permit (CUP), Development Review Permit (DRP) and Structure Development Permit (SDP) pursuant to Title 17 (Zoning) of the Solana Beach Municipal Code (SBMC) and City Council Policy 21; and

**WHEREAS**, the Applicant is proposing a new WCF location in order to replace a WCF being removed from the commercial structure at 505 Lomas Santa Fe; and

**WHEREAS**, at the hearing on December 13, 2017, the City Council received and considered evidence concerning the proposed application; and

**WHEREAS**, on December 13, 2017, the public hearing was conducted pursuant to the provisions of Solana Beach Municipal Code Section 17.72.030; and

**WHEREAS**, the City Council of the City of Solana Beach found the application request exempt from the California Environmental Quality Act pursuant to Section 15303 of the State CEQA Guidelines; and

**WHEREAS**, this decision is based upon the evidence presented at the hearings, and any information the City Council gathered by viewing the site and the area as disclosed at the hearing.

**NOW THEREFORE**, the City Council of the City of Solana Beach, California, does resolve as follows:

1. That the foregoing recitations are true and correct.
2. That the request for a CUP/DRP/SDP to construct new WCF consisting of an antenna enclosure at the top of the existing elevator tower, a rooftop equipment enclosure and a façade mounted antenna enclosure on the northeast corner of the third story of the existing commercial office building and a ground level equipment enclosure at 201 Lomas Santa Fe is conditionally approved based upon the following Findings and subject to the following Conditions:

**3. FINDINGS**

A. In accordance with Section 17.68.010 (Conditional Use Permit) of the City of Solana Beach Municipal Code, the City Council finds the following:

*I. Before granting a Conditional Use Permit, the Planning Director or City Council shall make all of the following findings:*

*a. The proposed use is in accord with the General Plan, the general intent of this title, and the purposes of the zone in which the site is located.*

General Plan Consistency: The proposed project, as conditioned, is consistent with the City's General Plan designation of Office/Professional which provides for professional office and general office in addition to other compatible uses such as religious facilities, educational institutions, parks and recreation facilities, and public utilities. Further, the proposed development is consistent with the objectives of the General Plan as it encourages the development of commercial land uses which strengthen the City's economic base and offer a range of commercial enterprises to meet the needs of the residents and visitors.

Zoning Ordinance Consistency: The proposed project is consistent with all applicable requirements of the Zoning Ordinance (Title 17), which delineates Permitted Uses and Structures (SBMC Section 17.24.020 and 17.24.030), and provides for uses which allow an Applicant to locate a commercial transmission and receiving antenna on a property within the OP Zone. Further, the proposed project adheres to all property development regulations established for the OP Zone and cited by the SBMC Section 17.24.030.

The design of the proposed project is consistent with the provisions for minimum yard dimensions (i.e. setbacks) and maximum building height. The project also complies with City Council 21 regulations as required by SBMC Section 17.60.120 for height, setbacks, proximity to residential uses, the uses of surrounding properties, quality and compatibility of design and screening, and impacts to public views and visual quality of the surrounding areas.

*b. The proposed use, together with the conditions applicable thereto, will not be detrimental to the public health, safety, or welfare, or materially injurious to properties or improvements in the vicinity.*

The Applicant has submitted an updated third party Radio Frequency Safety Survey Report Prediction prepared by

Waterford Compliance dated March 30, 2017. This report indicates that there would be a controlled access zone extending approximately 34 feet horizontally from the face of the antennas at roughly the height of the antennas at all four antenna sectors. The existence of the controlled access zone does not mean that the project violates the FCC rules; rather, it indicates that the carrier must affirmatively restrict public access to that area so that members of the general population (including trespassers) cannot unknowingly enter and be exposed to radio emissions in excess of those allowed by the FCC. Therefore, the project will not be detrimental to the public health, safety or welfare, or materially injurious to properties or improvement in the vicinity as determined by the FCC based on its exposure limits.

- c. *That the proposed use complies with each of the applicable provision of the zoning ordinance, unless a variance is granted pursuant to SBMC 17.68.020*

The proposed project complies with the property development regulations of SBMC 17.24.030, as well as the Wireless Communications Facilities guidelines of City Council Policy 21, which are required according to SBMC Section 17.60.120 for maximum height, setbacks, proximity to residential properties, impacts on public views and visual quality of the surrounding area.

- II. *If the Conditional Use Permit is for the purpose of permitting an expansion, restoration or extension of a nonconforming use or structure then only the findings of Chapter 17.16 SBMC must be made.*

The proposed project is not for the purpose of permitting an expansion, restoration or extension of a nonconforming use or structure.

- B. In accordance with Section 17.68.040 (Development Review Permit) of the City of Solana Beach Municipal Code, the City Council finds the following:

- I. *The proposed project is consistent with the General Plan and all applicable requirements of SBMC Title 17 (Zoning Ordinance), including special regulations, overlay zones, and specific plans.*

General Plan Consistency: The proposed project, as conditioned, is consistent with the City's General Plan designation of Office/Professional which provides for professional office and general office in addition to other compatible uses such as religious facilities, educational institutions, parks and recreation facilities, and public utilities. Further, the proposed development is consistent with the

objectives of the General Plan as it encourages the development of commercial land uses which strengthen the City's economic base and offer a range of commercial enterprises to meet the needs of the residents and visitors.

Zoning Ordinance Consistency: The proposed project is consistent with all applicable requirements of the Zoning Ordinance (Title 17), which delineates Permitted Uses and Structures (SBMC Section 17.24.020 and 17.24.030), and provides for uses which allow an Applicant to locate a commercial transmission and receiving antenna on a property within the OP Zone. Further, the proposed project adheres to all property development regulations established for the OP Zone and cited by the SBMC Section 17.24.030.

The design of the proposed project is consistent with the provisions for minimum yard dimensions (i.e. setbacks) and maximum building height. The project also complies with City Council 21 regulations as required by SBMC Section 17.60.120 for height, setbacks, proximity to residential uses, the uses of surrounding properties, quality and compatibility of design and screening, and impacts to public views and visual quality of the surrounding areas.

II. *The proposed development complies with the following development review criteria set forth in Solana Beach Municipal Code Section 17.68.040(F):*

- a. *Relationship with Adjacent Land Uses: The development shall be designed in a manner compatible with and complementary to existing development in the immediate vicinity of the project site and the surrounding neighborhood. The development as proposed shall also be compatible in scale, apparent bulk, and massing with such existing development in the surrounding neighborhood. Site planning on or near the perimeter of the development shall give consideration to the protection of surrounding areas from potential adverse effects.*

The property is located within the OP Zone and the SAOZ. Properties to the west are located within the Special Commercial (SC) Zone and developed with the Minute Shop liquor store, to the north are in the Light Commercial Zone and are developed with a two story mixed retail and office building. Properties to the east are located within the Low Medium Residential (LMR) Zone and to the south properties are within the Low Residential (LR) Zone. The residentially zoned lots are developed with a mix of one and two story, single family residences. The project site is currently developed with a multi-level office building with a parking lot located

towards the southern property line. The project, as designed, is consistent with the specific development standards of the OP Zone as described in SBMC Sections 17.24.010 and 17.12.020. The proposed development could be found to be consistent with the objectives of the General Plan as it encourages the development of commercial land uses which strengthen the City's economic base and offer a range of commercial enterprises to meet the needs of the residents and visitors.

The property is located within the SAOZ, however, as mentioned previously can be found exempt from the specific requirements of the overlay zone because it is a minor modification. As a condition of project approval, the Applicant would be required to obtain a Coastal Development Permit, Waiver or Exemption from the California Coastal Commission prior to the issuance of a Building Permit.

- b. *Building and Structure Placement: Buildings and structures shall be sited and designed to minimize adverse impacts on the surrounding properties and designed in a manner which visually and functionally enhance their intended use and complement existing site topography. Multi-family residential buildings shall be sited to avoid crowding and to allow for a functional use of the space between buildings.*

The proposed WCF addition would increase the height, depth, and width of the existing elevator enclosure in order to provide space to install three antennas in three sectors. Adjacent to the elevator enclosure an additional enclosure is proposed that would conceal 12 of the proposed RRU's and 2 of the surge suppressors. The fourth antenna sector would be located on the outer façade of northeast corner of the third story of the structure. All three antenna sectors would be screened with FRP screen boxes that are painted and textured to match the façade of the existing structure. The soil and vegetation will be removed from an existing planter area at the ground level in order to provide a below grade equipment enclosure.

The OP Zone has required setbacks of 15 feet for the front, 15 feet for a street side and 15 feet for the rear when it is abutting residentially zoned properties. As designed the proposed equipment enclosure would be setback approximately 70 feet from Lomas Santa Fe and the antenna enclosure would be setback approximately 90 feet. The maximum building height for the OP zone is 45 feet as measured from the lower of the existing or proposed grade, the tallest point of the proposed antenna enclosure would be approximately 39'-7" feet above the existing grade directly adjacent to the enclosure.

- c. *Landscaping: The removal of significant native vegetation shall be minimized. Replacement vegetation and landscaping shall be compatible with the vegetation of the surrounding area. To the maximum extent practicable, landscaping and plantings shall be used to screen parking areas, storage areas, access roads, and other service uses of the site. Trees and other large plantings shall not obstruct significant views when installed or at maturity. Drought tolerant plant materials and water conserving irrigation systems shall be incorporated into all landscaping plans.*

The project is not subject to the water efficient landscaping regulations of SBMC Chapter 17.56. According to SBMC Section 17.56.040, the regulations apply to modified irrigated landscaped areas that exceed 500 square feet. As designed, approximately 158 square feet of landscaped area will be removed in order to construct the equipment enclosure. The Applicant would remove a portion of the existing retaining wall that surrounds an existing landscape planter and excavate the soil and remove the existing vegetation in order to pour a concrete slab. In addition, an existing diseased tree adjacent to the proposed equipment enclosure would be removed and replaced with the proposed project.

- d. *Roads, Pedestrian Walkways, Parking and Storage Areas: Any development involving more than one building or structure shall provide common access roads and pedestrian walkways. Parking and outside storage areas, where permitted, shall be screened from view, to the extent feasible, by existing topography, by the placement of buildings and structures, or by landscaping and plantings.*

No additional parking is required for an unmanned WCF.

- e. *Grading: To the extent feasible, natural topography and scenic features of the site shall be retained and incorporated into the proposed development. Any grading or earth-moving operations in connection with the proposed development shall be planned and executed so as to blend with the existing terrain both on and adjacent to the site. Existing exposed or disturbed slopes shall be landscaped with native or naturalized non-native vegetation and existing erosion problems shall be corrected.*

The proposed grading quantities include 29.4 cubic yards for the excavation to be exported off-site in order to remove the existing plant and soil from the planter box and construct a below grade equipment enclosure for the proposed WCF.

- f. *Lighting: Light fixtures for walkways, parking areas, driveways, and other facilities shall be provided in sufficient number and at proper*

*locations to assure safe and convenient nighttime use. All light fixtures shall be appropriately shielded so that no light or glare is transmitted or reflected in such concentrated quantities or intensities as to be detrimental to the surrounding areas per SBMC 17.60.060 (Exterior Lighting Regulations).*

A condition of project approval includes that all new exterior lighting fixtures comply with the City-Wide Lighting Regulations of the Zoning Ordinance (SBMC 17.60.060). All light fixtures shall be shielded so that no light or glare is transmitted or reflected in such concentrated quantities or intensities as to be detrimental to the surrounding area.

- g. Usable Open Space: Recreational facilities proposed within required usable open space shall be located and designed to maintain essential open space values.*

The project consists of the construction of a new WCF on an existing office building, therefore, usable open space and recreational facilities are neither proposed nor required according to SBMC Section 17.20.040.

- III. All required permits and approvals issued by the City, including variances, conditional use permits, comprehensive sign plans, and coastal development permits, have been obtained prior to or concurrently with the development review permit.*

All required permits are being processed concurrently with the CUP. As a condition of project approval, the Applicant shall obtain approval from the CCC prior to issuance of Building Permits.

- IV. If the development project also requires a permit or approval to be issued by a state or federal agency, the city council may conditionally approve the development review permit upon the applicant obtaining the required permit or approval from the other agency.*

As a condition of project approval, the Applicant will be required to obtain approval from the California Coastal Commission (CCC) prior to the issuance of Building Permits.

- C. In accordance with Section 17.63.040 (Structure Development Permit) of the Solana Beach Municipal Code, the City Council finds the following:
  - I. Notices were mailed to all property owners and residents within 300 feet of the property and the deadline to file for View Assessment was November 22, 2017. No applications for View Assessment were received.

Therefore, the requirements for the approval of a SDP have been met. The SDP will be issued administratively with the CUP and DRP.

As a condition of project approval, once construction has begun, the Applicant will be required to submit a height certification prior to the framing inspection. The Height Certification will be signed by a licensed land surveyor and will verify that the framing materials and the proposed roofing materials will not exceed the maximum building height of 41.5 feet from the existing grade or 153.2 feet above MSL as approved by the SDP.

#### 4. CONDITIONS

Prior to use or development of the property in reliance on this permit, the Applicant shall provide for and adhere to the following conditions:

##### A. Community Development Department Conditions:

- I. Building Permit plans must be in substantial conformance with the plans presented to the City Council on January 10, 2018 located in the project file with a submittal date of January 3, 2018.
- II. The Applicant shall obtain required California Coastal Commission (CCC) approval of a Coastal Development Permit, Waiver or Exemption as determined necessary by the CCC, prior to the issuance of a building permit.
- III. Any new exterior lighting fixtures shall be in conformance with the City-Wide Lighting Regulations of SBMC 17.60.060.
- IV. All light fixtures shall be appropriately shielded so that no light or glare is transmitted or reflected in such concentrated quantities or intensities that render them detrimental to the surrounding area.
- V. This permit will automatically expire 10 years and one day from its issuance, except when California Government Code § 65964(b), as may be amended or superseded in the future, authorizes the City to establish a shorter term for public safety or substantial land use reasons. Any other permits or approvals issued in connection with any collocation, modification or other change to this wireless facility, which includes without limitation any permits or other approvals deemed-granted or deemed-approved under federal or state law, will not extend this term limit unless expressly provided otherwise in such permit or approval or required under federal or state law.
- VI. Before Permittee submits any applications to the Building Department, Permittee must incorporate this permit, all conditions



associated with this permit and the approved photo simulations into the project plans (the "**Approved Plans**"). Permittee must construct, install and operate the wireless facility in strict compliance with the Approved Plans. Any alterations, modifications or other changes to the Approved Plans, whether requested by Permittee or required by other departments or public agencies with jurisdiction over the wireless facility, must be submitted in a written request subject to the Director's prior review and approval, who may refer the request to the original approval authority if the Director finds that the requested alteration, modification or other change substantially deviates from the Approved Plans or implicates a significant or substantial land-use concern.

- VII. Permittee shall keep the site, which includes without limitation any and all improvements, equipment, structures, access routes, fences and landscape features, in a neat, clean and safe condition in accordance with the Approved Plans and all conditions in this permit. Permittee shall keep the site area free from all litter and debris at all times. Permittee, at no cost to the City, shall remove and remediate any graffiti or other vandalism at the site within 48 hours after Permittee receives notice or otherwise becomes aware that such graffiti or other vandalism occurred.
- VIII. Permittee shall maintain compliance at all times with all federal, state and local statutes, regulations, orders or other rules that carry the force of law ("**Laws**") applicable to Permittee, the subject property, the wireless facility or any use or activities in connection with the use authorized in this permit, which includes without limitation any Laws applicable to human exposure to RF emissions. Permittee expressly acknowledges and agrees that this obligation is intended to be broadly construed and that no other specific requirements in these conditions are intended to reduce, relieve or otherwise lessen Permittee's obligations to maintain compliance with all Laws. In the event that the City fails to timely notice, prompt or enforce compliance with any applicable provision in the Solana Beach Municipal Code, any permit, any permit condition or any applicable law or regulation, the applicant or permittee will not be relieved from its obligation to comply in all respects with all applicable provisions in the Solana Beach Municipal Code, any permit, any permit condition or any applicable law or regulation.
- IX. Permittee shall use all reasonable efforts to avoid any and all undue or unnecessary adverse impacts on nearby properties that may arise from Permittee's or its authorized personnel's construction, installation, operation, modification, maintenance, repair, removal and/or other activities at the site. Permittee shall not perform or cause others to perform any construction, installation, operation,

modification, maintenance, repair, removal or other work that involves heavy equipment or machines except during normal construction work hours authorized by the Solana Beach Municipal Code. The restricted work hours in this condition will not prohibit any work required to prevent an actual, immediate harm to property or persons, or any work during an emergency declared by the City. The Director or the Director's designee may issue a stop work order for any activities that violates this condition.

- X. Permittee expressly acknowledges and agrees that the City's officers, officials, staff or other designee may enter onto the site and inspect the improvements and equipment upon reasonable prior notice to Permittee; provided, however, that the City's officers, officials, staff or other designee may, but will not be obligated to, enter onto the site area without prior notice to support, repair, disable or remove any improvements or equipment in emergencies or when such improvements or equipment threatens actual, imminent harm to property or persons. Permittee will be permitted to supervise the City's officers, officials, staff or other designee while any such inspection or emergency access occurs.
- XI. Permittee shall furnish the Director with accurate and up-to-date contact information for a person responsible for the wireless facility, which includes without limitation such person's full name, title, direct telephone number, facsimile number, mailing address and email address. Permittee shall keep such contact information up-to-date at all times and immediately provide the Director with updated contact information in the event that either the responsible person or such person's contact information changes.
- XII. Permittee must maintain complete and accurate copies of all permits and other regulatory approvals issued in connection with the wireless facility, which includes without limitation this approval, the approved plans and photo simulations incorporated into this approval, all conditions associated with this approval and any ministerial permits or approvals issued in connection with this approval. In the event that Permittee does not maintain such records as required in this condition, any ambiguities or uncertainties that would be resolved through an inspection of the missing records will be construed against Permittee. Records may be kept in electronic format.
- XIII. Permittee shall taper the FRP screen walls to the existing building façade on all sides, beginning at the bottom 1/3 of the screen wall.
- XIV. Permittee shall paint and texture the vertical cable riser to match the existing alternating colors on the building.

- XV. Permittee shall paint and texture the FRP screen walls to match the existing color on the building at the height of the screen walls.
- XVI. Permittee shall paint and texture the CMU retaining walls around the equipment enclosure to match the existing walls in the stairwells.
- XVII. Permittee shall hire and pay for a licensed arborist to select, plant and maintain a replacement tree in an appropriate location for the species. Only ISA Certified tree workers under the supervision of a licensed arborist shall be used to install the replacement tree. The replacement tree shall be at least a 48" box size, and a type that generally does not exceed 25' in mature overall height, so as not to protrude above the roofline when viewed from vantage points in publicly accessible spaces to the east of the site location. The planting hole shall be at least three times the diameter of the root ball but only as deep as the root ball. The trunk flare at the base of the tree shall be visible after the replacement tree has been planted. Permittee shall, at all times, be responsible to maintain the replacement tree.
- XVIII. Permittee shall replace any landscape features damaged or displaced by the construction, installation, operation, maintenance or other work performed by Permittee or at Permittee's direction on or about the site.
- XIX. Permittee shall install, and at times maintain in good condition, all equipment, including without limitation antennas, remote radio units, power surge suppressors, GPS antennas, equipment cabinets, power cabinets, battery cabinets and utility panels, fully concealed from public view within FRP screening or the CMU wall enclosure, as applicable.
- XX. Permittee shall keep all access points to the main/uppermost rooftop area closed and locked at all times except when active maintenance is being performed on the main/uppermost rooftop or the equipment on the main/uppermost rooftop.
- XXI. Permittee shall install, and at all times maintain in good condition, an "RF Information" or "RF Notice" sign at any main/uppermost rooftop access point(s). Permittee shall install the sign(s) required under this condition so that a person may clearly see and understand the sign before he or she accesses the main/uppermost rooftop area. The sign(s) required under this condition shall be placed in a location where it will be visible whether the door, hatch or other barrier to the main/uppermost rooftop area is in both the open or closed position (e.g., placed on the wall adjacent to the door where it would not be covered by the door in the open position).

- XXII. Permittee shall install, and at all times maintain in good condition, a polyurethane chain-link barrier in approximately the locations shown in Figure 1 below. Permittee shall also install, and at all times maintain in good condition an "RF Caution" sign on the chain-link barrier in locations where they will be visible to a person approaching the antennas from the main/uppermost rooftop area. In the alternative, Permittee may install alternating floor stripes within the area shown in Figure 1.
- XXIII. Permittee shall keep the access point to the antenna enclosure closed and locked at all times, except when active maintenance is being performed on the antenna enclosure or the equipment within the antenna enclosure.
- XXIV. Permittee shall install, and at all times maintain in good condition, an "RF Caution" sign adjacent to the access ladder leading to the antenna enclosure. Permittee shall install the sign required under this condition so that a person may clearly see and understand the sign before he or she accesses the antenna enclosure. The sign required under this condition shall be placed in a location where it will be visible whether the door, hatch or other barrier to the antenna enclosure is in both the open or closed position.
- XXV. Permittee shall ensure that all signage complies with FCC OET Bulletin 65 or ANSI C95.2 for color, symbol, and content conventions. All such signage shall at all times provide a working local or toll-free telephone number to its network operations center, and such telephone number shall be able to reach a live person who can exert transmitter power-down control over this site as required by the FCC.
- XXVI. AT&T shall power-down the antennas whenever maintenance personnel other than AT&T perform any work on the roof of the building.
- XXVII. AT&T shall install and at all times maintain in good condition an RF Notice at all access points to the roof area. AT&T shall install the RF Notice signs in a location where anyone approaching the roof access point may clearly see the sign.
- XXVIII. AT&T shall install and at all times maintain in good condition a physical barrier that (1) restricts physical access to the controlled zones in front of the 50\* TN and 240\* TN sectors and (2) substantially conforms to the example provided in Figure 1, of the report dated December 5, 2013. Each barrier shall include an RF Caution sign placed where anyone approaching the barrier will clearly see it before entering the controlled zone.

- XXIX. AT&T shall ensure that all signs comply with FCC OET Bulletin 65 or ANSI C95.2 for color, symbol, and content conventions. All such signage shall at all times provide a working local or toll-free telephone number to its network operations center, and such telephone number shall be able to reach a live person who can exert transmitter power-down control over this site as required by the FCC.
- XXX. All equipment such as, but not limited to, emergency generators and air conditioners, shall be designed and operated consistent with the City's noise standards.
- XXXI. All facilities, related equipment, and landscaping shall be maintained in good condition and free from trash, debris, graffiti, and any form of vandalism. Damaged equipment and damaged, dead or decaying landscaping shall be replaced promptly.
- XXXII. Routine maintenance of equipment located in residential zones or within 100 feet of a residential district shall be conducted only during the hours of 8am and 5pm on weekdays, not including holidays. In other areas, routine maintenance may be conducted within a reasonable length of time to be determined by the City Manager or his designee in the cases of power outages and equipment failure or malfunction. Equipment "change out" and overhaul can occur any time within 30 days notice to the Director of Community Development to allow notice to property owners and residents within 300 feet of the facility.
- XXXIII. Maintenance shall not take place on Sundays or holidays.
- XXXIV. Security lighting should be kept to a minimum and should only be triggered by a motion detector where practical.
- XXXV. Within 6 months after the issuance of occupancy and with each time extension or amendment request, the developer/operator shall submit to the Planning Director either a verification that the WCF is categorically excluded from having to determine compliance with the guidelines per 47 CFR 1.1307(b)(1) or a project implementation report that provides cumulative field measurements of RF electromagnetic fields of all antennas installed at the subject site. The report shall quantify the RF emissions and compare the results with the project's preliminary proposal report submitted with the initial project application and the accepted ANSI/IEEE standards. If, on review, the Planning Director finds that the project does not meet ANSI/IEEE standards, the City may take any action necessary, as provided by law, to require compliance including, but not limited to, revoking the CUP.

XXXVI. Any WCF that is not operated for a continuous period of 90 days will be considered abandoned.

XXXVII. Within 90 days of receipt of notice from the City notifying the owner of such abandonment, the WCF owner must remove the facility and restore the site, as much as is reasonable and practical, to its prior condition. If such WCF is not removed within 90 days, the WCF will be considered a nuisance and in addition to any other available remedy, will be subject to abatement under Chapter 6.04 of the SBMC. If there are two or more users of a single WCF, then this provision will not become effective until all users stop using the WCF. The provider or owner must give notice to the City of the intent to discontinue use of any facility before discontinuing the use.

5. ENFORCEMENT: Pursuant to SBMC 17.72.120(B) failure to satisfy any and all of the above-mentioned conditions of approval is subject to the imposition of penalties as set forth in SBMC Chapters 1.1.6 and 1.18 in addition to any applicable revocation proceedings.
6. EXPIRATION: The Conditional Use Permit for WCF's shall be granted for a period not to exceed ten (10) years. Upon a request for either an extension of an amendment of a CUP, the WCF should be reevaluated to assess the impact of the facility on adjacent properties, the record of maintenance and performance with reference to the conditions of approval and consistency with these guidelines. The project will expire on December 13, 2027 or sooner if the WCF is not operated for a continuous period of 90 days in that case the WCF will be considered abandoned.
7. INDEMNIFICATION AGREEMENT: The Applicant shall defend, indemnify, and hold harmless the City, its agents, officers, and employees from any and all claims, actions, proceedings, damages, judgments, or costs, including attorney's fees, against the City or its agents, officers, or employees, relating to the issuance of this permit including, but not limited to, any action to attack, set aside, void, challenge, or annul this development approval and any environmental document or decision. The City will promptly notify Applicant of any claim, action, or proceeding. The City may elect to conduct its own defense, participate in its own defense, or obtain independent legal counsel in defense of any claim related to this indemnification. In the event of such election, Applicant shall pay all of the costs related thereto, including without limitation reasonable attorney's fees and costs. In the event of a disagreement between the City and Applicant regarding litigation issues, the City shall have the authority to control the litigation and make litigation related decisions, including, but not limited to, settlement or other disposition of the matter. However, the Applicant shall not be required to pay or perform any settlement unless such settlement is approved by Applicant.

8. NOTICE TO APPLICANT: Pursuant to Government Code Section 66020, you are hereby notified that the 90-day period to protest the imposition of the fees, dedications, reservations or other exactions described in this resolution commences on the effective date of this resolution. To protest the imposition of any fee, dedications, reservations or other exactions described in this resolution you must comply with the provisions of Government Code Section 66020. Generally the resolution is effective upon expiration of the tenth day following the date of adoption of this resolution, unless the resolution is appealed or called for review as provided in the Solana Beach Zoning Ordinance.

PASSED AND ADOPTED at a regular meeting of the City Council of the City of Solana Beach, California, held on the 10<sup>th</sup> day of January, 2018, by the following vote:

AYES: Councilmembers –

NOES: Councilmembers –

ABSENT: Councilmembers –

ABSTAIN: Councilmembers –

\_\_\_\_\_  
GINGER MARSHALL, Mayor

APPROVED AS TO FORM:

ATTEST:

\_\_\_\_\_  
JOHANNA N. CANLAS, City Attorney

\_\_\_\_\_  
ANGELA IVEY, City Clerk



# STAFF REPORT CITY OF SOLANA BEACH

**TO:** Honorable Mayor and City Councilmembers  
**FROM:** Gregory Wade, City Manager  
**MEETING DATE:** December 13, 2017  
**ORIGINATING DEPT:** Community Development Department  
**SUBJECT:** **CUP/DRP/SDP for a New Wireless Communications Facility at 201 Lomas Santa Fe (Case # 17-17-15 Applicant: AT&T Mobility) Resolution 2017-166**

---

## **BACKGROUND:**

The Applicant, AT&T Mobility (hereinafter referred to as "Applicant"), is requesting the approval of a Conditional Use Permit (CUP), Development Review Permit (DRP) and Structure Development Permit (SDP) to construct a new Wireless Communication Facility (WCF) on top of an existing commercial office building at 201 Lomas Santa Fe. The Applicant is proposing to increase the height of an existing elevator tower in order to construct a new antenna enclosure that would conceal 12 panel antennas, 32 Remote Radio Units (RRU's), six surge suppressors, and two GPS antennas behind fiber reinforced plastic screening colored and textured to match the existing building. A new ground level equipment enclosure that would contain four stack-mounted radio equipment cabinets, one power cabinet, one battery cabinet and telephone and electric utility panels on a concrete slab foundation. The enclosure would be located in the location that is currently a landscape planter adjacent to the building entrance. The antenna enclosure would increase the width and depth of the top 12 feet of the existing tower by three feet and the height by four feet. The highest point of the proposed antennas will be 41.5 feet above the existing grade and 153.2 feet above the existing grade. Solana Beach Municipal Code (SBMC) section 17.60.120(G)(1) indicates that all WCF's are subject to a CUP and must comply with City Council Policy 21. A DRP is required for "any new commercial development or construction (including any structural addition to existing development) located within any commercial zone which results in an increase of more than 500 feet of gross floor area or to the overall building envelope." The proposed addition would exceed 16 feet in height from the existing grade and therefore, requires a Structure Development Permit (SDP).

This item is before the City Council to approve, conditionally approve or deny the Applicant's request for a CUP, DRP, and SDP for a new WCF at 201 Lomas Santa Fe, Solana Beach, as contained in Resolution 2017-167 (Attachment 1).

CITY COUNCIL ACTION:

---

---



## **DISCUSSION:**

The new WCF at 201 Lomas Santa Fe is proposed in order to relocate an existing site that is being decommissioned due to an expired lease at the current property. The existing property is on the southeast corner of the intersection of Lomas Santa Fe and South Rios Avenue. The property is currently developed with a commercial office structure commonly known as the Wedbush Building. The property is located within the Scenic Area Overlay Zone (SAOZ). The proposed project can be found exempt from the SAOZ regulations according to SBMC 17.48.101.D.1, because it is considered a minor addition to an existing structure, which doesn't increase the existing building envelope or floor area by more than 10 percent or require more than 50 cubic yards of grading.

A CUP is required to locate a commercial transmission and receiving antenna on a property within the Office Professional (OP) Zone. Solana Beach Municipal Code (SBMC) Section 17.60.120.G requires the approval of a CUP for all WCF's that are in compliance with City Council Policy 21. City Council Policy 21 indicates that WCF's are allowed in all zones with the approval of a CUP that is in compliance with the guidelines established by the policy and that these shall be followed in the review of CUP's for new WCF's as well as extensions and amendments to existing installations. A DRP is required for "any new commercial development or construction (including any structural addition to existing development) located within any commercial zone which results in an increase of more than 500 feet of gross floor area or to the overall building envelope." And a Structure Development Permit (SDP) is required for this project pursuant to SBMC section 17.63.040.A because the proposed addition exceeds 16 feet in height from the existing grade.

A draft Resolution has been provided based upon the information provided in this report and the City consultant's analysis of the proposed project. It includes the applicable SBMC sections in italicized text. Council may direct Staff to modify the Resolution to reflect the findings and conditions it deems appropriate as a part of the Public Hearing process.

### Conditional Use Permit:

In addition to meeting zoning requirements, the Council can approve, or conditionally approve a CUP only if all of the findings listed below can be made.

1. Before granting a conditional use permit, the Planning Director or City Council shall make all of the following findings:
  - a. That the proposed use is in accord with the general plan, the general intent of this title, and the purposes of the zone in which the site is located.

- b. That the proposed use, together with the conditions applicable thereto, will not be detrimental to the public health, safety, or welfare, or materially injurious to properties or improvements in the vicinity.
  - c. That the proposed use complies with each of the applicable provisions of the zoning ordinance, unless a variance is granted pursuant to SBMC 17.68.020.
2. If the conditional use permit is for the purpose of permitting an expansion, restoration, or extension of a nonconforming use or structure then only the findings of Chapter 17.16 SBMC must be made.

According to City Council Policy 21, the City Council shall consider the following factors when reviewing a CUP for a WCF:

- a. Compliance with the guidelines listed in Council Policy 21
- b. Height and Setbacks
- c. Proximity to residential uses
- d. The nature of uses on adjacent and nearby properties
- e. Surrounding topography and landscape
- f. Quality and compatibility of design and screening
- g. Impacts on public views and the visual quality of the surrounding area
- h. Availability of other facilities and buildings for co-location

The proposed WCF is proposed to be located on an existing building that is located on property within the Office Professional (OP) Zone. According to the County Assessor's records the existing structure was constructed onsite prior to the City's Incorporation. As designed, the project includes the construction of a new antenna enclosure on the top of the existing elevator tower in order to mount 12 panel antennas, 32 Remote Radio Units (RRU's), six surge suppressors, and two GPS antennas behind fiber reinforced plastic screening colored and textured to match the existing building. The Applicant would remove a portion of the existing retaining wall that surrounds an existing landscape planter and excavate the soil and remove the existing vegetation in order to pour a concrete slab for an equipment enclosure. A new door and landing would also be constructed to provide access to the equipment enclosure. Inside the enclosure the Applicant would install four stack-mounted radio equipment cabinets, one power cabinet, one battery cabinet and telephone and electric utility panels. In addition, an existing diseased tree adjacent to the proposed equipment enclosure would be removed and replaced with the proposed project. Project plans are provided in Attachment 2.

The proposed project could be found to be consistent with the City's General Plan designation of Office/Professional which provides for professional office and general office in addition to other compatible uses such as religious facilities, educational institutions, parks and recreation facilities, and public utilities. Further, the proposed development is consistent with the objectives of the General Plan as it encourages the development of commercial land uses which strengthen the City's economic base and offer a range of commercial enterprises to meet the needs of the residents and visitors.

Telecom Law Firm PC is the City's third-party telecom consultant hired to review all WCF projects submitted to the City. They have provided three reports providing their analysis of the proposed site (Attachment 3). Their analysis includes the following: 1) whether Section 6409(a) applies to the subject project, 2) whether the proposed project complies with the Solana Beach Municipal Code and City Council Policy 21, 3) whether potential alternatives exist that deserve additional consideration, and 4) whether the proposed site demonstrates planned compliance with the federal radio frequency exposure guidelines.

The project site is not subject to Section 6409(a) of the Middle Class Tax Relief and Job Creation Act of 2012 regarding mandatory approval because AT&T is proposing to construct a new site rather than collocate or modify the transmission equipment of an existing site.

In 2008, the City Council adopted Council Policy 21 to establish the review and approval guidelines for Wireless Communications Facilities. Council Policy 21, section A.1 Location Guidelines for Placement of WCF's, lists the preferred locations for WCF's in descending order of preference. The fourth most preferred location is on property within the "Other Non-Residential Zones" (which would include the OP Zone).

Council Policy 21, Section A.2, requires that in all areas of the City:

*WCFs should locate where least visible to the public and where least disruptive to the appearance of the host property. Furthermore, no WCF should be installed on an exposed ridgeline or in a location readily visible from a public place, recreation area, scenic area or residential area unless it is satisfactorily located and/or screened so it is hidden or disguised to fit with the surrounding site design, architecture, and landscaping.*

No portion of the proposed antenna supports or equipment will be visible to the public. The proposed antenna enclosure will be constructed to screen all of the proposed antennas and RRU's. The remaining equipment proposed with this permit will be placed in a below grade equipment enclosure previously used as a landscape planter.

Section B.1 Design Guidelines indicates that:

*All aspects of the WCF, including the supports, antennas, screening methods, and equipment shall exhibit "stealth" design techniques so they visually blend into the background or the surface on which they are mounted. Subject to City approval, developers should use false architectural elements (e.g., cupolas, bell towers, dormers, and chimneys), architectural treatments (e.g., colors and materials), elements replicating natural features (e.g., trees and rocks), landscaping, and other creative means to hide or disguise WCFs. Stealth can also refer to facilities completely hidden by existing improvements, such as parapet walls.*

The original project design did not comply with maximum height limit for the OP Zone and other potential sites within the area were identified that would rank higher under the Council Policy 21 stealth design and location guidelines. Staff had the Applicant provide an analysis of several other single and multi-site locations with the surrounding area that could be considered as potential alternative site locations. However, in order to consider these sites, additional information was required. The analysis of these locations is discussed in more detail in the reports provided by Telecom Law Firm PC (Attachment 3). The Applicant has since redesigned the project to be in compliance with the maximum building height regulations of the zone. Therefore, the proposed project could be found to be in compliance with Council Policy 21 and the underlying zoning regulations. If the Council determines that they are unable to make the required findings and approve the project, Staff would request additional information from the Applicant in order to fully analyze the alternative site locations discussed in the attached reports.

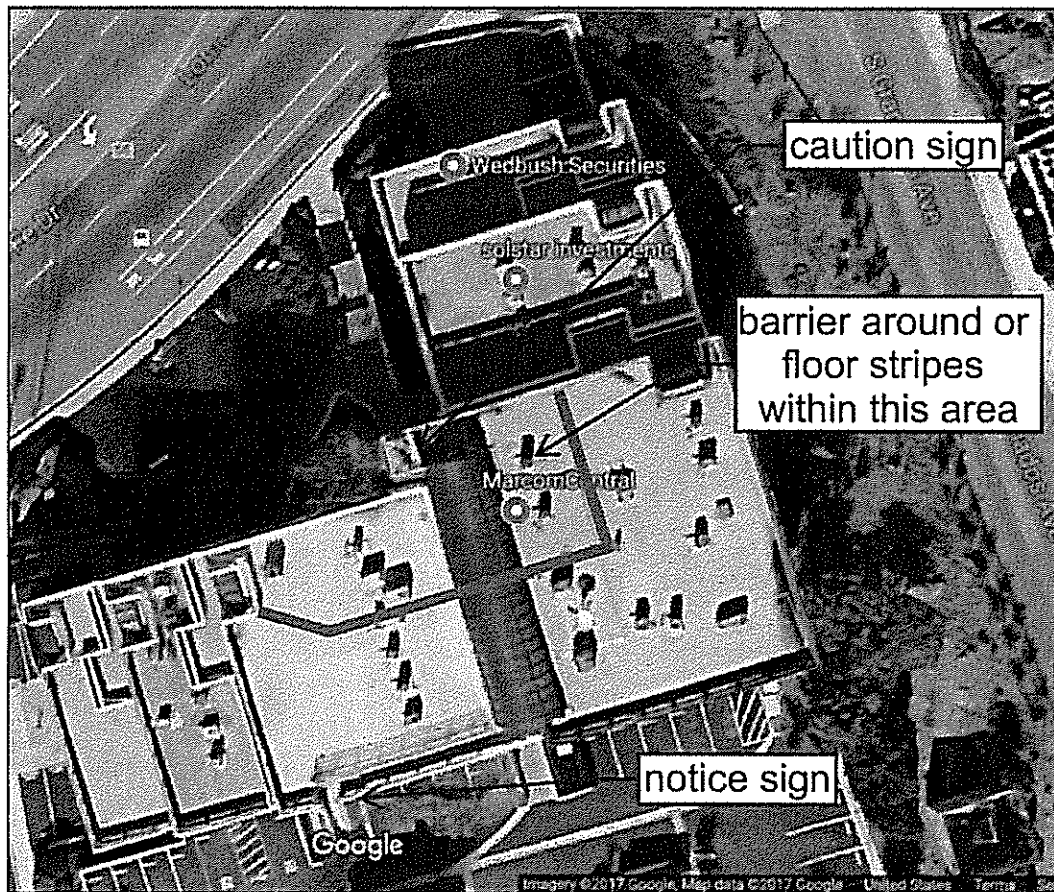
As designed, the proposed antenna enclosure will be located at the top of the existing elevator tower on the north side of the existing building. The enclosure will increase the width and depth of the top 12 feet of the tower by approximately three feet and will increase the overall height of the tower by four feet. The height of the tower would be 41.5 feet from the existing grade directly adjacent to the tower. The highest portion of the antenna enclosure would be at the same height as the existing skylight. The SBMC indicates that the maximum building height for the OP Zone is 45 feet in height. City Council Policy 21 indicates that WCF's should adhere to the existing height limitations for structures and buildings of the zone in which they are located. Because the tallest point of the panel antennas is below 45 feet, it could be found that the proposed antennas adhere to the height limitations for the structures of the zone in which they are located.

According to SBMC 17.28.030, the minimum required setbacks for development in the OP Zone are 15 feet for the front, zero feet for the rear and 15 feet for the street side yards. If the property abuts a residentially zoned property to the side or rear, the required setback is increased to 15 feet. Council Policy 21 indicates that all WCF's and proposed equipment should adhere to the building setbacks for the Zone in which they are located. The Policy also requires that if the project site is next to a residential zone, the WCF should be set back from the residential boundary a minimum distance equal to the above-ground height of the antenna. The property directly east of the site is zoned Low Medium Residential (LMR) and properties to the south of the site are zoned Low Residential (LR). Properties north are Zoned Light Commercial (LC) and west are Special Commercial (SC). As designed, the proposed WCF meets the required setbacks and the closest residentially zoned property is located 175 feet to the south. The proposed antenna and equipment enclosures could be found in compliance with the setback requirements.

The Federal Communications Commission sets the safety standards for Radio Frequency (RF) in the United States. The City is not permitted to set its own standards regardless of whether higher, lower, or even the same as the FCC's standards. The Commission does permit the City to determine whether the proposed wireless project meets the required RF safety requirements. The Applicant provided a RF emissions

report. The Federal Communications Commission (FCC) indicates that certain types of wireless projects are deemed to be categorically excluded or not subject to further RF evaluation if the antennas' supporting structure is not a building or shared to perform some other function and the lowest portion of the transmitting antenna is at least 10 meters above ground (approximately 32.8 feet). The proposed project does not qualify for this categorical exclusion because the antennas are attached to an occupied building. The Applicant has submitted an updated third party Radio Frequency Safety Survey Report Prediction prepared by Waterford Compliance dated March 30, 2017. This report indicates that there would be a controlled access zone extending approximately 34 feet horizontally from the face of the antennas at roughly the height of the antennas at all four antenna sectors. The existence of the controlled access zone does not mean that the project violates the FCC rules; rather, it indicates that the carrier must affirmatively restrict public access to that area so that members of the general population (including trespassers) cannot unknowingly enter and be exposed to radio emissions in excess of those allowed by the FCC. To comply with the existing FCC rules and FCC OET Bulletin 65 rules regarding RF safety, conditions of project approval have been recommended that require the following:

1. Permittee shall keep all access points to the main/uppermost rooftop area closed and locked at all times except when active maintenance is being performed on the main/uppermost rooftop or the equipment on the main/uppermost rooftop.
2. Permittee shall install, and at all times maintain in good condition, an "RF Information" or "RF Notice" sign at any main/uppermost rooftop access point(s). Permittee shall install the sign(s) required under this condition so that a person may clearly see and understand the sign before he or she accesses the main/uppermost rooftop area. The sign(s) required under this condition shall be placed in a location where it will be visible whether the door, hatch or other barrier to the main/uppermost rooftop area is in both the open or closed position (e.g., placed on the wall adjacent to the door where it would not be covered by the door in the open position).
3. Permittee shall install, and at all times maintain in good condition, a polyurethane chain-link barrier in approximately the locations shown in Figure 1 below. Permittee shall also install, and at all times maintain in good condition an "RF Caution" sign on the chain-link barrier in locations where they will be visible to a person approaching the antennas from the main/uppermost rooftop area. In the alternative, Permittee may install alternating floor stripes within the area shown in the figure below:



4. Permittee shall keep the access point to the antenna enclosure closed and locked at all times, except when active maintenance is being performed on the antenna enclosure or the equipment within the antenna enclosure.
5. Permittee shall install, and at all times maintain in good condition, an "RF Caution" sign adjacent to the access ladder leading to the antenna enclosure. Permittee shall install the sign required under this condition so that a person may clearly see and understand the sign before he or she accesses the antenna enclosure. The sign required under this condition shall be placed in a location where it will be visible whether the door, hatch or other barrier to the antenna enclosure is in both the open or closed position.
6. Permittee shall ensure that all signage complies with FCC OET Bulletin 65 or ANSI C95.2 for color, symbol, and content conventions. All such signage shall at all times provide a working local or toll-free telephone number to its network operations center, and such telephone number shall be able to reach a live person who can exert transmitter power-down control over this site as required by the FCC.

As conditioned, the project will not be detrimental to the public health, safety or welfare, or materially injurious to properties or improvement in the vicinity as determined by the FCC based on its exposure limits.

Development Review Permit Compliance (SBMC Section 17.68.40):

A DRP is required for "any new commercial development or construction (including any structural addition to existing development) located within any commercial zone which results in an increase of more than 500 feet of gross floor area or to the overall building envelope."

In addition to meeting the zoning requirements, the project must also be found in compliance with development review criteria. The following is a list of the development review criteria topics:

1. Relationship with Adjacent Land Uses
2. Building and Structure Placement
3. Landscaping
4. Roads, Pedestrian Walkways, Parking, and Storage Areas
5. Grading
6. Lighting
7. Usable Open Space

The Council may approve, or conditionally approve, a DRP only if all of the findings listed below can be made. Resolution 2017-167 provides the full discussion of the required findings below:

1. The proposed development is consistent with the general plan and all applicable requirements of this title, including special regulations, overlay zones, and specific plans.
2. The proposed development complies with the development review criteria.
3. All required permits and approvals issued by the city, including variances, conditional use permits, comprehensive sign plans, and coastal development permits have been obtained prior to or concurrently with the development review permit.
4. If the development project also requires a permit or approval to be issued by a state or federal agency, the city council may conditionally approve the development review permit upon the applicant obtaining the required permit or approval from the other agency.

If the above findings cannot be made, the Council shall deny the DRP. The following is a discussion of the applicable development review criteria as they relate to the proposed project.

#### Relationship with Adjacent Land Uses:

The property is located within the OP Zone and the SAOZ. Properties to the west are located within the Special Commercial (SC) Zone and developed with the Minute Shop liquor store, to the north are in the Light Commercial Zone and are developed with a two story mixed retail and office building. Properties to the east are located within the Low Medium Residential (LMR) Zone and to the south properties are within the Low Residential (LR) Zone. The residentially zoned lots are developed with a mix of one and two story, single family residences. The project site is currently developed with a multi-level office building with a parking lot located towards the southern property line. The project, as designed, is consistent with the specific development standards of the OP Zone as described in SBMC Sections 17.24.010 and 17.12.020. The proposed development could be found to be consistent with the objectives of the General Plan as it encourages the development of commercial land uses which strengthen the City's economic base and offer a range of commercial enterprises to meet the needs of the residents and visitors.

The property is located within the SAOZ, however, as mentioned previously can be found exempt from the specific requirements of the overlay zone because it is a minor modification. As a condition of project approval, the Applicant would be required to obtain a Coastal Development Permit, Waiver or Exemption from the California Coastal Commission prior to the issuance of a Building Permit.

#### Building and Structure Placement:

The proposed WCF addition would increase the height, depth, and width of the existing elevator enclosure in order to provide space to install three antennas in four sectors and associated equipment. The soil and vegetation will be removed from an existing planter area at the ground level in order to provide a below grade equipment enclosure.

The OP Zone has required setbacks of 15 feet for the front, 15 feet for a street side and 15 feet for the rear when it is abutting residentially zoned properties. As designed the proposed equipment enclosure would be setback approximately 70 feet from Lomas Santa Fe and the antenna enclosure would be setback approximately 90 feet. The maximum building height for the OP zone is 45 feet as measured from the lower of the existing or proposed grade, the tallest point of the proposed antenna enclosure would be approximately 41.5 feet above the existing grade directly adjacent to the enclosure.

#### Fences, Walls and Retaining Walls:

A portion of an existing retaining wall will be removed and replaced with the construction of the equipment enclosure. A condition of approval has been added to require that the Applicant paint and texture the CMU retaining walls around the equipment enclosure to match the existing walls in the stairwells.



#### Landscape:

The project is not subject to the water efficient landscaping regulations of SBMC Chapter 17.56. According to SBMC Section 17.56.040, the regulations apply to modified irrigated landscaped areas that exceed 500 square feet. As designed, approximately 158 square feet of landscaped area will be removed in order to construct the below grade equipment enclosure. The Applicant would remove a portion of the existing retaining wall that surrounds an existing landscape planter and excavate the soil and remove the existing vegetation in order to pour a concrete slab. In addition, an existing diseased tree adjacent to the proposed equipment enclosure would be removed and replaced with the proposed project.

#### Parking:

No additional parking is required for an unmanned WCF.

#### Grading:

The proposed grading quantities include 29.4 cubic yards for the excavation to be exported off-site in order to remove the existing plant and soil from the planter box and construct a below grade equipment enclosure for the proposed WCF.

#### Lighting:

A condition of project approval includes that all new exterior lighting fixtures comply with the City-Wide Lighting Regulations of the Zoning Ordinance (SBMC 17.60.060). All light fixtures shall be shielded so that no light or glare is transmitted or reflected in such concentrated quantities or intensities as to be detrimental to the surrounding area.

#### Usable Open Space:

The project consists of the construction of a new WCF on an existing office building, therefore, usable open space and recreational facilities are neither proposed nor required according to SBMC Section 17.20.040.

#### Structure Development Permit Compliance:

The proposed antenna enclosure will exceed 16 feet in height from the pre-existing grade therefore, the project must comply with all of the requirements of SBMC Chapter 17.63 (View Assessment) and the Applicants must complete the SDP process. Story poles were erected onsite and a Story Pole Height Certificate was issued by a licensed land surveyor on August 2, 2017, which showed a maximum building height of 41.5 feet. The highest story pole was certified at 153.2 feet above Mean Sea Level (MSL) as measured from the existing grade.

Notices were mailed to all property owners and residents within 300 feet of the property and the deadline to file for View Assessment was November 22, 2017. No applications

for view assessment were received. Therefore, the requirements for the approval of a SDP have been met. The SDP will be issued administratively with the CUP and DRP should the Council determine that the findings can be made to approve the project.

As a condition of project approval, once construction has begun, the Applicant will be required to submit a height certification, prior to the framing inspection, for the tallest portion of the proposed antenna enclosure. The Height Certification will be signed by a licensed land surveyor and will verify that the framing materials and the proposed roofing materials will not exceed the maximum building heights approved by the SDP.

**Public Hearing Notice:**

Notices of the City Council public hearing for the project were mailed to property owners and occupants within 300 feet of the proposed project site more than 10 days prior to the planned public hearing date of December 13, 2017. As of the date of preparation of this Staff Report, Staff has not received any letters, phone calls, or e-mails from neighbors or interested parties in support of, or in opposition to, the proposed project.

Conditions from the Community Development Department as well as the City's consultant have been incorporated into the Resolution of Approval (Attachment 1). In conclusion, Staff recommends the City Council adopt Resolution 2017-167.

**CEQA COMPLIANCE STATEMENT:**

The project is exempt from the California Environmental Quality Act (CEQA) pursuant to Section 15301 of the State CEQA Guidelines.

**FISCAL IMPACT:** N/A

**WORKPLAN:** N/A

**OPTIONS:**

- Approve Staff recommendation adopting the attached Resolution 2017-167.
- Approve Staff recommendation subject to additional specific conditions necessary for the City Council to make all required findings for the approval of a CUP and DRP.
- Direct Staff to analyze alternative site locations.
- Deny the project if all required findings for the CUP and/or the DRP cannot be made.

**DEPARTMENT RECOMMENDATION:**

Because the Act mandates that the project be approved, Staff recommends that the City Council:

1. Conduct the Public Hearing: Open the Public Hearing, Report Council disclosures, Receive public testimony, Close the Public Hearing.
2. Find the project exempt from the California Environmental Quality Act pursuant to Section 15301 of the State CEQA Guidelines; and
3. Adopt Resolution 2017-167 conditionally approving a CUP/DRP/SDP for a new WCF and associated equipment located on the roof of an existing commercial office building at 201 Lomas Santa Fe, Solana Beach.

**CITY MANAGER'S RECOMMENDATION:**

Approve Department Recommendation.



Gregory Wade, City Manager

Attachments:

1. Resolution 2017-167
2. Project Plans
3. Report from Telecom Law Firm

**RESOLUTION NO. 2017-167**

**A RESOLUTION OF THE CITY COUNCIL OF THE CITY OF SOLANA BEACH, CALIFORNIA, CONDITIONALLY APPROVING A CONDITIONAL USE PERMIT, DEVELOPMENT REVIEW PERMIT AND STRUCTURE DEVELOPMENT PERMIT FOR A NEW WIRELESS COMMUNICATIONS FACILITY LOCATED ON THE EXISTING COMMERCIAL STRUCTURE AT 201 LOMAS SANTA FE, SOLANA BEACH**

**APPLICANT: AT&T Mobility**  
**CASE NO.: 17-17-15 CUP/DRP/SDP**

**WHEREAS**, AT&T Mobility (hereinafter referred to as "Applicant") has submitted an application for a Conditional Use Permit (CUP), Development Review Permit (DRP) and Structure Development Permit (SDP) pursuant to Title 17 (Zoning) of the Solana Beach Municipal Code (SBMC) and City Council Policy 21; and

**WHEREAS**, the Applicant is proposing a new WCF location in order to replace a WCF being removed from the commercial structure at 505 Lomas Santa Fe; and

**WHEREAS**, at the hearing on December 13, 2017, the City Council received and considered evidence concerning the proposed application; and

**WHEREAS**, on December 13, 2017, the public hearing was conducted pursuant to the provisions of Solana Beach Municipal Code Section 17.72.030; and

**WHEREAS**, the City Council of the City of Solana Beach found the application request exempt from the California Environmental Quality Act pursuant to Section 15303 of the State CEQA Guidelines; and

**WHEREAS**, this decision is based upon the evidence presented at the hearings, and any information the City Council gathered by viewing the site and the area as disclosed at the hearing.

**NOW THEREFORE**, the City Council of the City of Solana Beach, California, does resolve as follows:

1. That the foregoing recitations are true and correct.
2. That the request for a CUP/DRP/SDP to construct a new WCF located on the top of the existing elevator tower of an existing commercial office building and a ground level equipment enclosure at 201 Lomas Santa Fe is conditionally approved based upon the following Findings and subject to the following Conditions:
3. FINDINGS
  - A. In accordance with Section 17.68.010 (Conditional Use Permit) of the City of

Solana Beach Municipal Code, the City Council finds the following:

*I. Before granting a Conditional Use Permit, the Planning Director or City Council shall make all of the following findings:*

*a. The proposed use is in accord with the General Plan, the general intent of this title, and the purposes of the zone in which the site is located.*

General Plan Consistency: The proposed project, as conditioned, is consistent with the City's General Plan designation of Office/Professional which provides for professional office and general office in addition to other compatible uses such as religious facilities, educational institutions, parks and recreation facilities, and public utilities. Further, the proposed development is consistent with the objectives of the General Plan as it encourages the development of commercial land uses which strengthen the City's economic base and offer a range of commercial enterprises to meet the needs of the residents and visitors.

Zoning Ordinance Consistency: The proposed project is consistent with all applicable requirements of the Zoning Ordinance (Title 17), which delineates Permitted Uses and Structures (SBMC Section 17.24.020 and 17.24.030), and provides for uses which allow an Applicant to locate a commercial transmission and receiving antenna on a property within the OP Zone. Further, the proposed project adheres to all property development regulations established for the OP Zone and cited by the SBMC Section 17.24.030.

The design of the proposed project is consistent with the provisions for minimum yard dimensions (i.e. setbacks) and maximum building height. The project also complies with City Council 21 regulations as required by SBMC Section 17.60.120 for height, setbacks, proximity to residential uses, the uses of surrounding properties, quality and compatibility of design and screening, and impacts to public views and visual quality of the surrounding areas.

*b. The proposed use, together with the conditions applicable thereto, will not be detrimental to the public health, safety, or welfare, or materially injurious to properties or improvements in the vicinity.*

The Applicant has submitted an updated third party Radio Frequency Safety Survey Report Prediction prepared by Waterford Compliance dated March 30, 2017. This report

indicates that there would be a controlled access zone extending approximately 34 feet horizontally from the face of the antennas at roughly the height of the antennas at all four antenna sectors. The existence of the controlled access zone does not mean that the project violates the FCC rules; rather, it indicates that the carrier must affirmatively restrict public access to that area so that members of the general population (including trespassers) cannot unknowingly enter and be exposed to radio emissions in excess of those allowed by the FCC. Therefore, the project will not be detrimental to the public health, safety or welfare, or materially injurious to properties or improvement in the vicinity as determined by the FCC based on its exposure limits.

- c. That the proposed use complies with each of the applicable provision of the zoning ordinance, unless a variance is granted pursuant to SBMC 17.68.020*

The proposed project complies with the property development regulations of SBMC 17.24.030, as well as the Wireless Communications Facilities guidelines of City Council Policy 21, which are required according to SBMC Section 17.60.120 for maximum height, setbacks, proximity to residential properties, impacts on public views and visual quality of the surrounding area.

- II. If the Conditional Use Permit is for the purpose of permitting an expansion, restoration or extension of a nonconforming use or structure then only the findings of Chapter 17.16 SBMC must be made.*

The proposed project is not for the purpose of permitting an expansion, restoration or extension of a nonconforming use or structure.

- B. In accordance with Section 17.68.040 (Development Review Permit) of the City of Solana Beach Municipal Code, the City Council finds the following:

- I. The proposed project is consistent with the General Plan and all applicable requirements of SBMC Title 17 (Zoning Ordinance), including special regulations, overlay zones, and specific plans.*

General Plan Consistency: The proposed project, as conditioned, is consistent with the City's General Plan designation of Office/Professional which provides for professional office and general office in addition to other compatible uses such as religious facilities, educational institutions, parks and recreation facilities, and public utilities. Further, the proposed development is consistent with the objectives of the General Plan as it encourages the

development of commercial land uses which strengthen the City's economic base and offer a range of commercial enterprises to meet the needs of the residents and visitors.

Zoning Ordinance Consistency: The proposed project is consistent with all applicable requirements of the Zoning Ordinance (Title 17), which delineates Permitted Uses and Structures (SBMC Section 17.24.020 and 17.24.030), and provides for uses which allow an Applicant to locate a commercial transmission and receiving antenna on a property within the OP Zone. Further, the proposed project adheres to all property development regulations established for the OP Zone and cited by the SBMC Section 17.24.030.

The design of the proposed project is consistent with the provisions for minimum yard dimensions (i.e. setbacks) and maximum building height. The project also complies with City Council 21 regulations as required by SBMC Section 17.60.120 for height, setbacks, proximity to residential uses, the uses of surrounding properties, quality and compatibility of design and screening, and impacts to public views and visual quality of the surrounding areas.

ii. *The proposed development complies with the following development review criteria set forth in Solana Beach Municipal Code Section 17.68.040(F):*

a. *Relationship with Adjacent Land Uses: The development shall be designed in a manner compatible with and complementary to existing development in the immediate vicinity of the project site and the surrounding neighborhood. The development as proposed shall also be compatible in scale, apparent bulk, and massing with such existing development in the surrounding neighborhood. Site planning on or near the perimeter of the development shall give consideration to the protection of surrounding areas from potential adverse effects.*

The property is located within the OP Zone and the SAOZ. Properties to the west are located within the Special Commercial (SC) Zone and developed with the Minute Shop liquor store, to the north are in the Light Commercial Zone and are developed with a two story mixed retail and office building. Properties to the east are located within the Low Medium Residential (LMR) Zone and to the south properties are within the Low Residential (LR) Zone. The residentially zoned lots are developed with a mix of one and two story, single family residences. The project site is currently developed with a multi-level office building with a parking lot located towards the southern property line. The project, as designed, is

consistent with the specific development standards of the OP Zone as described in SBMC Sections 17.24.010 and 17.12.020. The proposed development could be found to be consistent with the objectives of the General Plan as it encourages the development of commercial land uses which strengthen the City's economic base and offer a range of commercial enterprises to meet the needs of the residents and visitors.

The property is located within the SAOZ, however, as mentioned previously can be found exempt from the specific requirements of the overlay zone because it is a minor modification. As a condition of project approval, the Applicant would be required to obtain a Coastal Development Permit, Waiver or Exemption from the California Coastal Commission prior to the issuance of a Building Permit.

- b. *Building and Structure Placement: Buildings and structures shall be sited and designed to minimize adverse impacts on the surrounding properties and designed in a manner which visually and functionally enhance their intended use and complement existing site topography. Multi-family residential buildings shall be sited to avoid crowding and to allow for a functional use of the space between buildings.*

The proposed WCF addition would increase the height, depth, and width of the existing elevator enclosure in order to provide space to install three antennas in four sectors and associated equipment. The soil and vegetation will be removed from an existing planter area at the ground level in order to provide a below grade equipment enclosure.

The OP Zone has required setbacks of 15 feet for the front, 15 feet for a street side and 15 feet for the rear when it is abutting residentially zoned properties. As designed the proposed equipment enclosure would be setback approximately 70 feet from Lomas Santa Fe and the antenna enclosure would be setback approximately 90 feet. The maximum building height for the OP zone is 45 feet as measured from the lower of the existing or proposed grade, the tallest point of the proposed antenna enclosure would be approximately 41.5 feet above the existing grade directly adjacent to the enclosure.

- c. *Landscaping: The removal of significant native vegetation shall be minimized. Replacement vegetation and landscaping shall be compatible with the vegetation of the surrounding area. To the maximum extent practicable, landscaping and plantings shall be used to screen parking areas, storage areas, access roads, and other service uses of the site. Trees and other large plantings shall not obstruct significant views when installed or at maturity. Drought*



*tolerant plant materials and water conserving irrigation systems shall be incorporated into all landscaping plans.*

The project is not subject to the water efficient landscaping regulations of SBMC Chapter 17.56. According to SBMC Section 17.56.040, the regulations apply to modified irrigated landscaped areas that exceed 500 square feet. As designed, approximately 158 square feet of landscaped area will be removed in order to construct the equipment enclosure. The Applicant would remove a portion of the existing retaining wall that surrounds an existing landscape planter and excavate the soil and remove the existing vegetation in order to pour a concrete slab. In addition, an existing diseased tree adjacent to the proposed equipment enclosure would be removed and replaced with the proposed project.

- d. *Roads, Pedestrian Walkways, Parking and Storage Areas: Any development involving more than one building or structure shall provide common access roads and pedestrian walkways. Parking and outside storage areas, where permitted, shall be screened from view, to the extent feasible, by existing topography, by the placement of buildings and structures, or by landscaping and plantings.*

No additional parking is required for an unmanned WCF.

- e. *Grading: To the extent feasible, natural topography and scenic features of the site shall be retained and incorporated into the proposed development. Any grading or earth-moving operations in connection with the proposed development shall be planned and executed so as to blend with the existing terrain both on and adjacent to the site. Existing exposed or disturbed slopes shall be landscaped with native or naturalized non-native vegetation and existing erosion problems shall be corrected.*

The proposed grading quantities include 29.4 cubic yards for the excavation to be exported off-site in order to remove the existing plant and soil from the planter box and construct a below grade equipment enclosure for the proposed WCF.

- f. *Lighting: Light fixtures for walkways, parking areas, driveways, and other facilities shall be provided in sufficient number and at proper locations to assure safe and convenient nighttime use. All light fixtures shall be appropriately shielded so that no light or glare is transmitted or reflected in such concentrated quantities or intensities as to be detrimental to the surrounding areas per SBMC 17.60.060 (Exterior Lighting Regulations).*

A condition of project approval includes that all new exterior lighting fixtures comply with the City-Wide Lighting Regulations of the Zoning Ordinance (SBMC 17.60.060). All light fixtures shall be shielded so that no light or glare is transmitted or reflected in such concentrated quantities or intensities as to be detrimental to the surrounding area.

- g. Usable Open Space: Recreational facilities proposed within required usable open space shall be located and designed to maintain essential open space values.*

The project consists of the construction of a new WCF on an existing office building, therefore, usable open space and recreational facilities are neither proposed nor required according to SBMC Section 17.20.040.

- III. All required permits and approvals issued by the City, including variances, conditional use permits, comprehensive sign plans, and coastal development permits, have been obtained prior to or concurrently with the development review permit.*

All required permits are being processed concurrently with the CUP. As a condition of project approval, the Applicant shall obtain approval from the CCC prior to issuance of Building Permits.

- IV. If the development project also requires a permit or approval to be issued by a state or federal agency, the city council may conditionally approve the development review permit upon the applicant obtaining the required permit or approval from the other agency.*

As a condition of project approval, the Applicant will be required to obtain approval from the California Coastal Commission (CCC) prior to the issuance of Building Permits.

- C. In accordance with Section 17.63.040 (Structure Development Permit) of the Solana Beach Municipal Code, the City Council finds the following:
  - I. Notices were mailed to all property owners and residents within 300 feet of the property and the deadline to file for View Assessment was November 22, 2017. No applications for View Assessment were received.

Therefore, the requirements for the approval of a SDP have been met. The SDP will be issued administratively with the CUP and DRP.

As a condition of project approval, once construction has begun, the Applicant will be required to submit a height certification prior to the framing inspection. The Height Certification will be signed by a

licensed land surveyor and will verify that the framing materials and the proposed roofing materials will not exceed the maximum building height of 41.5 feet from the existing grade or 153.2 feet above MSL as approved by the SDP.

#### 4. CONDITIONS

Prior to use or development of the property in reliance on this permit, the Applicant shall provide for and adhere to the following conditions:

##### A. Community Development Department Conditions:

- I. Building Permit plans must be in substantial conformance with the plans presented to the City Council on December 13, 2017, located in the project file with a submittal date of November 30, 2017.
- II. The Applicant shall obtain required California Coastal Commission (CCC) approval of a Coastal Development Permit, Waiver or Exemption as determined necessary by the CCC, prior to the issuance of a building permit.
- III. Any new exterior lighting fixtures shall be in conformance with the City-Wide Lighting Regulations of SBMC 17.60.060.
- IV. All light fixtures shall be appropriately shielded so that no light or glare is transmitted or reflected in such concentrated quantities or intensities that render them detrimental to the surrounding area.
- V. This permit will automatically expire 10 years and one day from its issuance, except when California Government Code § 65964(b), as may be amended or superseded in the future, authorizes the City to establish a shorter term for public safety or substantial land use reasons. Any other permits or approvals issued in connection with any collocation, modification or other change to this wireless facility, which includes without limitation any permits or other approvals deemed-granted or deemed-approved under federal or state law, will not extend this term limit unless expressly provided otherwise in such permit or approval or required under federal or state law.
- VI. Before Permittee submits any applications to the Building Department, Permittee must incorporate this permit, all conditions associated with this permit and the approved photo simulations into the project plans (the "**Approved Plans**"). Permittee must construct, install and operate the wireless facility in strict compliance with the Approved Plans. Any alterations, modifications or other changes to the Approved Plans, whether requested by Permittee or required by other departments or public agencies with jurisdiction over the wireless facility, must be submitted in a written request subject to the

Director's prior review and approval, who may refer the request to the original approval authority if the Director finds that the requested alteration, modification or other change substantially deviates from the Approved Plans or implicates a significant or substantial land-use concern.

- VII. Permittee shall keep the site, which includes without limitation any and all improvements, equipment, structures, access routes, fences and landscape features, in a neat, clean and safe condition in accordance with the Approved Plans and all conditions in this permit. Permittee shall keep the site area free from all litter and debris at all times. Permittee, at no cost to the City, shall remove and remediate any graffiti or other vandalism at the site within 48 hours after Permittee receives notice or otherwise becomes aware that such graffiti or other vandalism occurred.
- VIII. Permittee shall maintain compliance at all times with all federal, state and local statutes, regulations, orders or other rules that carry the force of law ("Laws") applicable to Permittee, the subject property, the wireless facility or any use or activities in connection with the use authorized in this permit, which includes without limitation any Laws applicable to human exposure to RF emissions. Permittee expressly acknowledges and agrees that this obligation is intended to be broadly construed and that no other specific requirements in these conditions are intended to reduce, relieve or otherwise lessen Permittee's obligations to maintain compliance with all Laws. In the event that the City fails to timely notice, prompt or enforce compliance with any applicable provision in the Solana Beach Municipal Code, any permit, any permit condition or any applicable law or regulation, the applicant or permittee will not be relieved from its obligation to comply in all respects with all applicable provisions in the Solana Beach Municipal Code, any permit, any permit condition or any applicable law or regulation.
- IX. Permittee shall use all reasonable efforts to avoid any and all undue or unnecessary adverse impacts on nearby properties that may arise from Permittee's or its authorized personnel's construction, installation, operation, modification, maintenance, repair, removal and/or other activities at the site. Permittee shall not perform or cause others to perform any construction, installation, operation, modification, maintenance, repair, removal or other work that involves heavy equipment or machines except during normal construction work hours authorized by the Solana Beach Municipal Code. The restricted work hours in this condition will not prohibit any work required to prevent an actual, immediate harm to property or persons, or any work during an emergency declared by the City. The Director or the Director's designee may issue a stop work order for

any activities that violates this condition.

- X. Permittee expressly acknowledges and agrees that the City's officers, officials, staff or other designee may enter onto the site and inspect the improvements and equipment upon reasonable prior notice to Permittee; provided, however, that the City's officers, officials, staff or other designee may, but will not be obligated to, enter onto the site area without prior notice to support, repair, disable or remove any improvements or equipment in emergencies or when such improvements or equipment threatens actual, imminent harm to property or persons. Permittee will be permitted to supervise the City's officers, officials, staff or other designee while any such inspection or emergency access occurs.
- XI. Permittee shall furnish the Director with accurate and up-to-date contact information for a person responsible for the wireless facility, which includes without limitation such person's full name, title, direct telephone number, facsimile number, mailing address and email address. Permittee shall keep such contact information up-to-date at all times and immediately provide the Director with updated contact information in the event that either the responsible person or such person's contact information changes.
- XII. Permittee must maintain complete and accurate copies of all permits and other regulatory approvals issued in connection with the wireless facility, which includes without limitation this approval, the approved plans and photo simulations incorporated into this approval, all conditions associated with this approval and any ministerial permits or approvals issued in connection with this approval. In the event that Permittee does not maintain such records as required in this condition, any ambiguities or uncertainties that would be resolved through an inspection of the missing records will be construed against Permittee. Records may be kept in electronic format.
- XIII. Permittee shall taper the FRP screen walls to the existing building façade on all sides, beginning at the bottom 1/3 of the screen wall.
- XIV. Permittee shall paint and texture the vertical cable riser to match the existing alternating colors on the building.
- XV. Permittee shall paint and texture the FRP screen walls to match the existing color on the building at the height of the screen walls.
- XVI. Permittee shall paint and texture the CMU retaining walls around the equipment enclosure to match the existing walls in the stairwells.
- XVII. Permittee shall hire and pay for a licensed arborist to select, plant

and maintain a replacement tree in an appropriate location for the species. Only ISA Certified tree workers under the supervision of a licensed arborist shall be used to install the replacement tree. The replacement tree shall be at least a 48" box size, and a type that generally does not exceed 25' in mature overall height, so as not to protrude above the roofline when viewed from vantage points in publicly accessible spaces to the east of the site location. The planting hole shall be at least three times the diameter of the root ball but only as deep as the root ball. The trunk flare at the base of the tree shall be visible after the replacement tree has been planted. Permittee shall, at all times, be responsible to maintain the replacement tree.

- XVIII. Permittee shall replace any landscape features damaged or displaced by the construction, installation, operation, maintenance or other work performed by Permittee or at Permittee's direction on or about the site.
- XIX. Permittee shall install, and at times maintain in good condition, all equipment, including without limitation antennas, remote radio units, power surge suppressors, GPS antennas, equipment cabinets, power cabinets, battery cabinets and utility panels, fully concealed from public view within FRP screening or the CMU wall enclosure, as applicable.
- XX. Permittee shall keep all access points to the main/uppermost rooftop area closed and locked at all times except when active maintenance is being performed on the main/uppermost rooftop or the equipment on the main/uppermost rooftop.
- XXI. Permittee shall install, and at all times maintain in good condition, an "RF Information" or "RF Notice" sign at any main/uppermost rooftop access point(s). Permittee shall install the sign(s) required under this condition so that a person may clearly see and understand the sign before he or she accesses the main/uppermost rooftop area. The sign(s) required under this condition shall be placed in a location where it will be visible whether the door, hatch or other barrier to the main/uppermost rooftop area is in both the open or closed position (e.g., placed on the wall adjacent to the door where it would not be covered by the door in the open position).
- XXII. Permittee shall install, and at all times maintain in good condition, a polyurethane chain-link barrier in approximately the locations shown in Figure 1 below. Permittee shall also install, and at all times maintain in good condition an "RF Caution" sign on the chain-link barrier in locations where they will be visible to a person approaching the antennas from the main/uppermost rooftop area. In the

alternative, Permittee may install alternating floor stripes within the area shown in Figure 1.

- XXIII. Permittee shall keep the access point to the antenna enclosure closed and locked at all times, except when active maintenance is being performed on the antenna enclosure or the equipment within the antenna enclosure.
- XXIV. Permittee shall install, and at all times maintain in good condition, an "RF Caution" sign adjacent to the access ladder leading to the antenna enclosure. Permittee shall install the sign required under this condition so that a person may clearly see and understand the sign before he or she accesses the antenna enclosure. The sign required under this condition shall be placed in a location where it will be visible whether the door, hatch or other barrier to the antenna enclosure is in both the open or closed position.
- XXV. Permittee shall ensure that all signage complies with FCC OET Bulletin 65 or ANSI C95.2 for color, symbol, and content conventions. All such signage shall at all times provide a working local or toll-free telephone number to its network operations center, and such telephone number shall be able to reach a live person who can exert transmitter power-down control over this site as required by the FCC.
- XXVI. AT&T shall power-down the antennas whenever maintenance personnel other than AT&T perform any work on the roof of the building.
- XXVII. AT&T shall install and at all times maintain in good condition an RF Notice at all access points to the roof area. AT&T shall install the RF Notice signs in a location where anyone approaching the roof access point may clearly see the sign.
- XXVIII. AT&T shall install and at all times maintain in good condition a physical barrier that (1) restricts physical access to the controlled zones in front of the 50\* TN and 240\* TN sectors and (2) substantially conforms to the example provided in Figure 1, of the report dated December 5, 2013. Each barrier shall include an RF Caution sign placed where anyone approaching the barrier will clearly see it before entering the controlled zone.
- XXIX. AT&T shall ensure that all signs comply with FCC OET Bulletin 65 or ANSI C95.2 for color, symbol, and content conventions. All such signage shall at all times provide a working local or toll-free telephone number to its network operations center, and such telephone number shall be able to reach a live person who can exert transmitter power-down control over this site as required by the FCC.

- XXX. All equipment such as, but not limited to, emergency generators and air conditioners, shall be designed and operated consistent with the City's noise standards.
- XXXI. All facilities, related equipment, and landscaping shall be maintained in good condition and free from trash, debris, graffiti, and any form of vandalism. Damaged equipment and damaged, dead or decaying landscaping shall be replaced promptly.
- XXXII. Routine maintenance of equipment located in residential zones or within 100 feet of a residential district shall be conducted only during the hours of 8am and 5pm on weekdays, not including holidays. In other areas, routine maintenance may be conducted within a reasonable length of time to be determined by the City Manager or his designee in the cases of power outages and equipment failure or malfunction. Equipment "change out" and overhaul can occur any time within 30 days notice to the Director of Community Development to allow notice to property owners and residents within 300 feet of the facility.
- XXXIII. Maintenance shall not take place on Sundays or holidays.
- XXXIV. Security lighting should be kept to a minimum and should only be triggered by a motion detector where practical.
- XXXV. Within 6 months after the issuance of occupancy and with each time extension or amendment request, the developer/operator shall submit to the Planning Director either a verification that the WCF is categorically excluded from having to determine compliance with the guidelines per 47 CFR 1.1307(b)(1) or a project implementation report that provides cumulative field measurements of RF electromagnetic fields of all antennas installed at the subject site. The report shall quantify the RF emissions and compare the results with the project's preliminary proposal report submitted with the initial project application and the accepted ANSI/IEEE standards. If, on review, the Planning Director finds that the project does not meet ANSI/IEEE standards, the City may take any action necessary, as provided by law, to require compliance including, but not limited to, revoking the CUP.
- XXXVI. Any WCF that is not operated for a continuous period of 90 days will be considered abandoned.
- XXXVII. Within 90 days of receipt of notice from the City notifying the owner of such abandonment, the WCF owner must remove the facility and restore the site, as much as is reasonable and practical, to its prior



condition. If such WCF is not removed within 90 days, the WCF will be considered a nuisance and in addition to any other available remedy, will be subject to abatement under Chapter 6.04 of the SBMC. If there are two or more users of a single WCF, then this provision will not become effective until all users stop using the WCF. The provider or owner must give notice to the City of the intent to discontinue use of any facility before discontinuing the use.

5. ENFORCEMENT: Pursuant to SBMC 17.72.120(B) failure to satisfy any and all of the above-mentioned conditions of approval is subject to the imposition of penalties as set forth in SBMC Chapters 1.1.6 and 1.18 in addition to any applicable revocation proceedings.
6. EXPIRATION: The Conditional Use Permit for WCF's shall be granted for a period not to exceed ten (10) years. Upon a request for either an extension of an amendment of a CUP, the WCF should be reevaluated to assess the impact of the facility on adjacent properties, the record of maintenance and performance with reference to the conditions of approval and consistency with these guidelines. The project will expire on December 13, 2027 or sooner if the WCF is not operated for a continuous period of 90 days in that case the WCF will be considered abandoned.
7. INDEMNIFICATION AGREEMENT: The Applicant shall defend, indemnify, and hold harmless the City, its agents, officers, and employees from any and all claims, actions, proceedings, damages, judgments, or costs, including attorney's fees, against the City or its agents, officers, or employees, relating to the issuance of this permit including, but not limited to, any action to attack, set aside, void, challenge, or annul this development approval and any environmental document or decision. The City will promptly notify Applicant of any claim, action, or proceeding. The City may elect to conduct its own defense, participate in its own defense, or obtain independent legal counsel in defense of any claim related to this indemnification. In the event of such election, Applicant shall pay all of the costs related thereto, including without limitation reasonable attorney's fees and costs. In the event of a disagreement between the City and Applicant regarding litigation issues, the City shall have the authority to control the litigation and make litigation related decisions, including, but not limited to, settlement or other disposition of the matter. However, the Applicant shall not be required to pay or perform any settlement unless such settlement is approved by Applicant.
8. NOTICE TO APPLICANT: Pursuant to Government Code Section 66020, you are hereby notified that the 90-day period to protest the imposition of the fees, dedications, reservations or other exactions described in this resolution commences on the effective date of this resolution. To protest the imposition of any fee, dedications, reservations or other exactions described in this resolution you must comply with the provisions of Government Code Section 66020. Generally the resolution is effective upon expiration of the tenth day following the

date of adoption of this resolution, unless the resolution is appealed or called for review as provided in the Solana Beach Zoning Ordinance.

PASSED AND ADOPTED at a regular meeting of the City Council of the City of Solana Beach, California, held on the 13<sup>th</sup> day of December, 2017, by the following vote:

AYES: Councilmembers –

NOES: Councilmembers –

ABSENT: Councilmembers –

ABSTAIN: Councilmembers –

\_\_\_\_\_  
MIKE NICHOLS, Mayor

APPROVED AS TO FORM:

ATTEST:

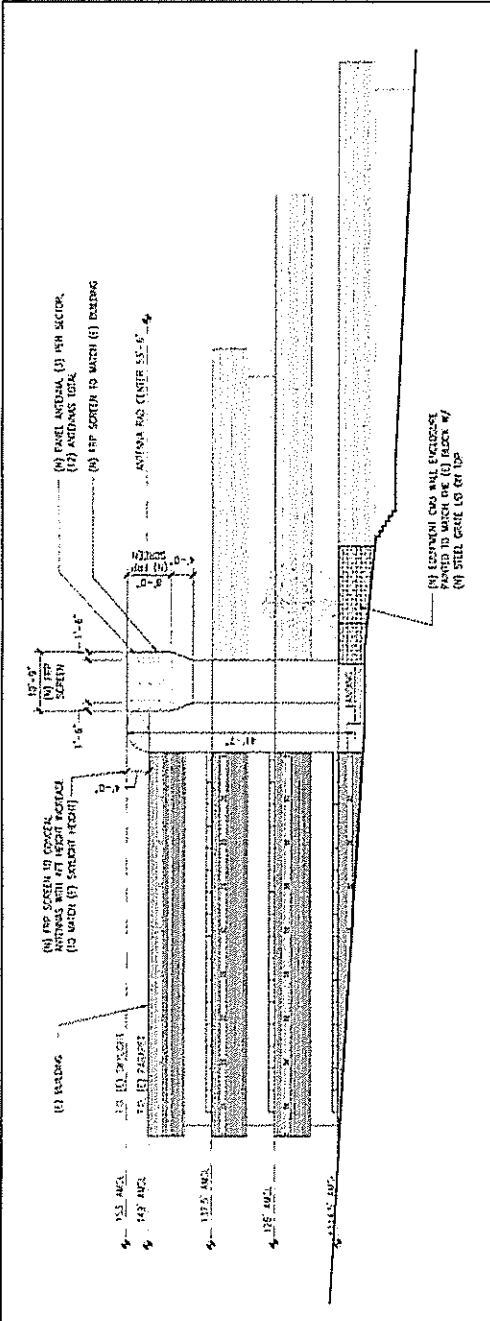
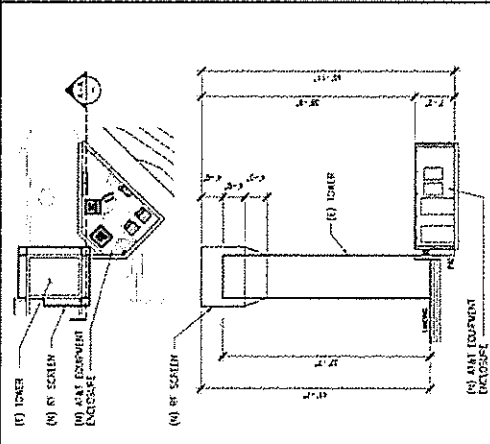
\_\_\_\_\_  
JOHANNA N. CANLAS, City Attorney

\_\_\_\_\_  
ANGELA IVEY, City Clerk

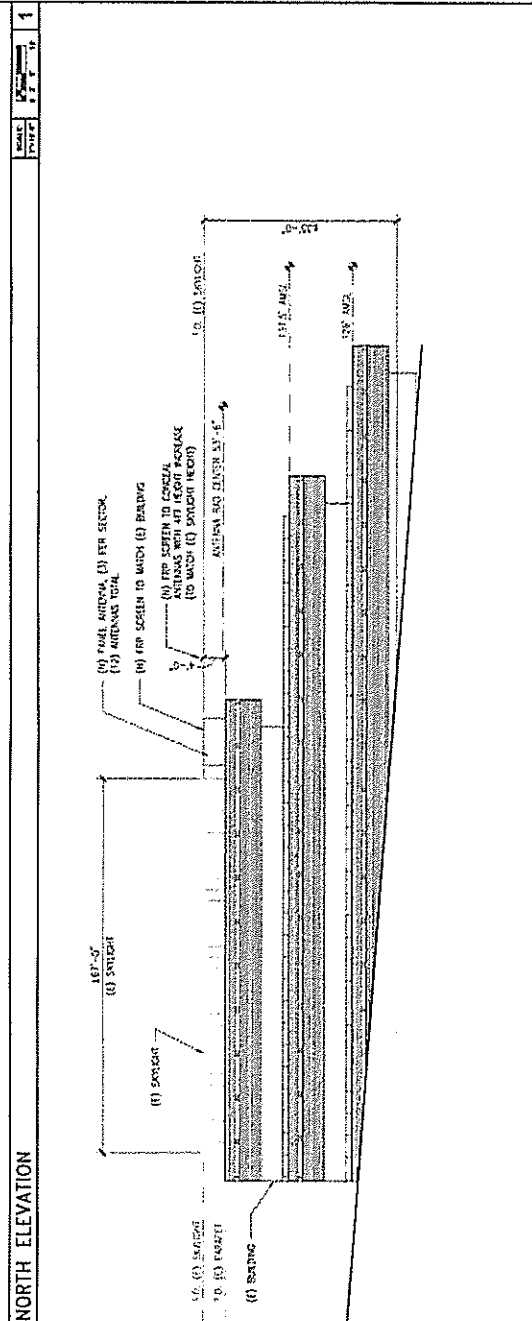
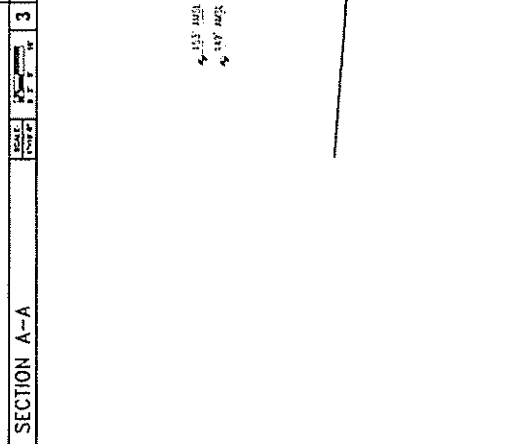








SECTION A-A 3 NORTH ELEVATION 1



SECTION A-A 3 EAST ELEVATION 2

at&t 1311 FORD STREET, SUITE 1000 SAN JOSE, CA 95128		DePratti Inc.		SD0925 LOHAS SANTA FE 200 LOHAS SANTA FE DRIVE SOLAN COUNTY, CA 94725		DCI PACIFIC AIRIC WORKS 4000 AIRIC DRIVE SANTA FE, NM 87507		ELEVATION		A03	
SCALE	DATE	BY	CHECKED	DATE	BY	CHECKED	DATE	BY	CHECKED	DATE	BY
SCALE: AS SHOWN	DATE: 11/20/03	BY: J. BROWN	CHECKED: J. BROWN	DATE: 11/20/03	BY: J. BROWN	CHECKED: J. BROWN	DATE: 11/20/03	BY: J. BROWN	CHECKED: J. BROWN	DATE: 11/20/03	BY: J. BROWN
<p>1. (E) PANEL ANTENNA (3) PER SECTION</p> <p>2. (E) ANTENNAS TOTAL</p> <p>3. (E) AIR SCREEN TO MATCH (E) BEARING</p> <p>4. (E) AIR SCREEN TO CORRELATE ANTENNAS WITH AIR HEIGHT PACKAGE (TO MATCH (E) SCREEN HEIGHT)</p> <p>5. (E) BEARING</p> <p>6. (E) ANTENNA RIG CENTER 53'-6"</p> <p>7. (E) EQUIPMENT CASE SHALL BE COLORED PAINTED TO MATCH (E) (E) BLACK W/ (E) STEEL CASE L&amp;P ON TOP</p>											

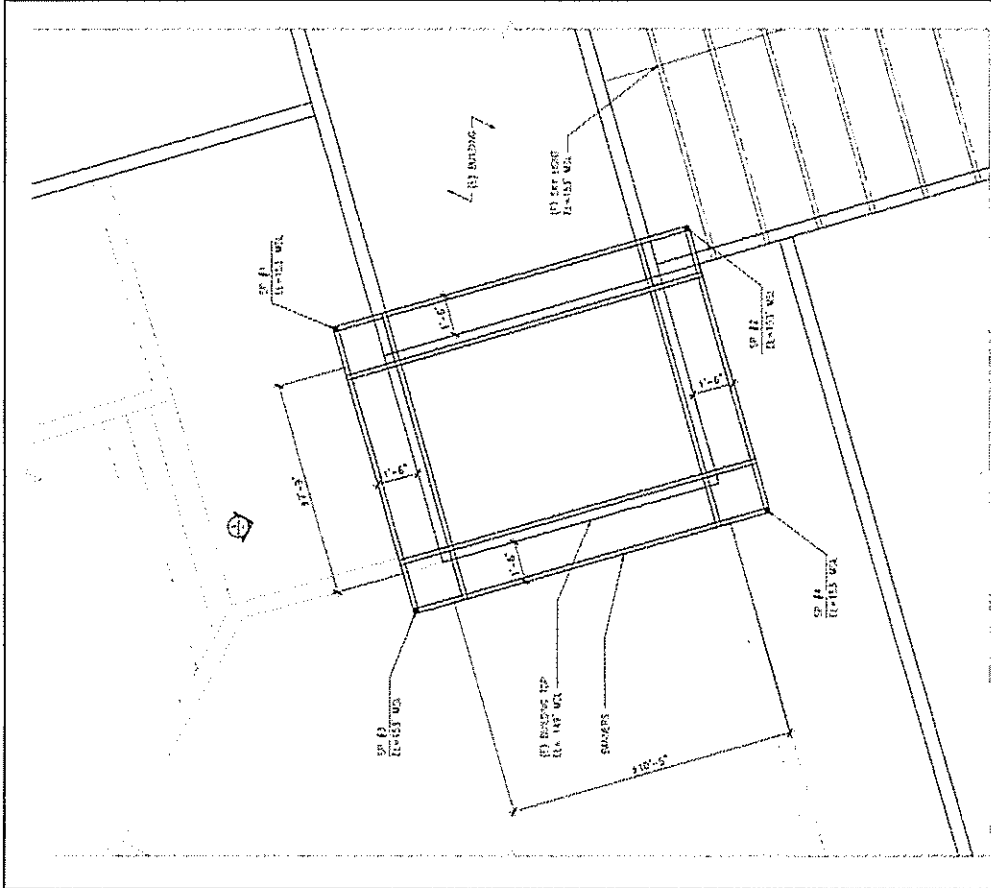
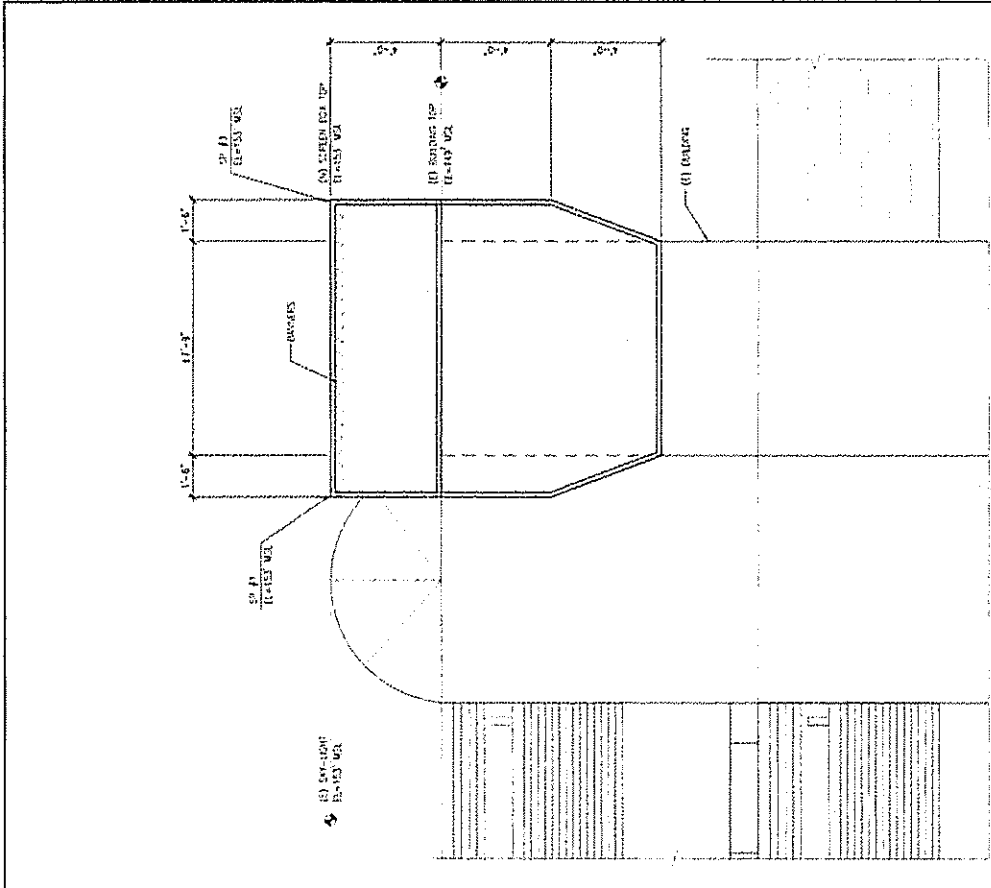




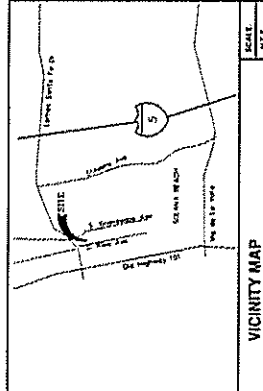




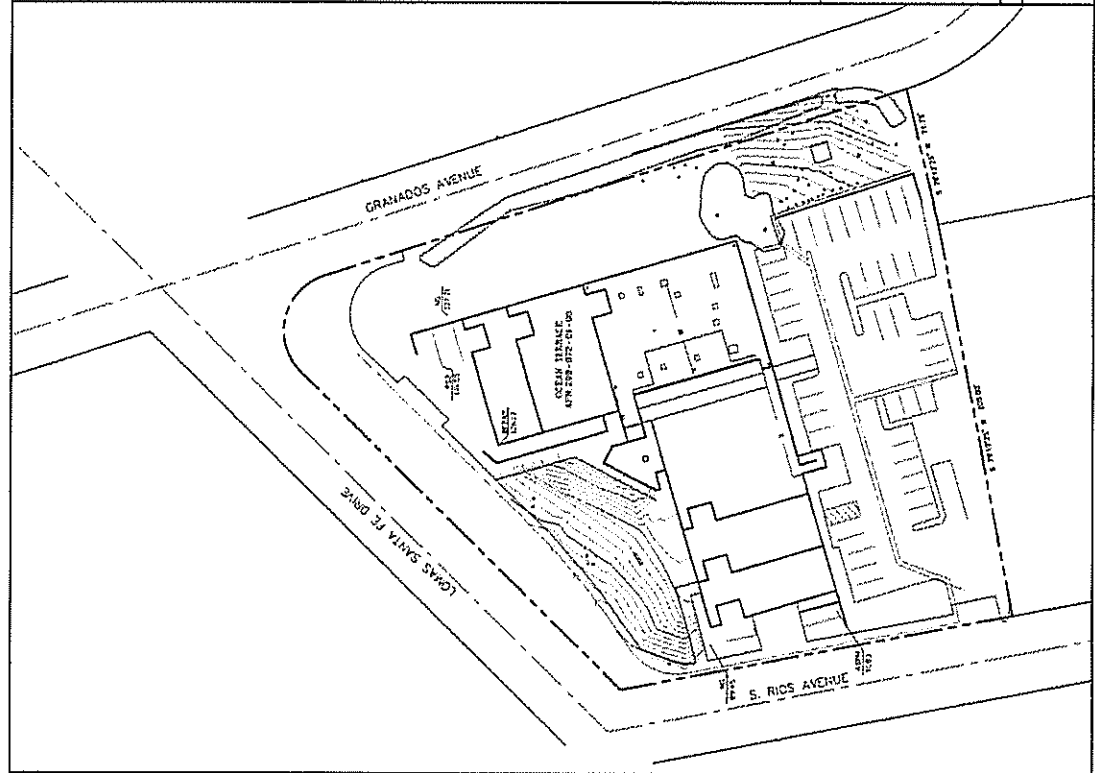




OVERHEAD VIEW		2 STORY POLE ELEVATION		1																																																								
SCALE	DATE	SCALE	DATE	SCALE	DATE																																																							
1/8" = 1'-0"	10/10/10	1/4" = 1'-0"	10/10/10	1/4" = 1'-0"	10/10/10																																																							
SD0925 LONAS SANTA FE 19A LONAS SANTA FE DRIVE SANTA FE, NM 87505			STORY POLE PLOT PLAN C01																																																									
DePratti Inc.			DCI PACIFIC A/E/C WORKS 11000 WILLOW CREEK DRIVE SANTA ANA, CA 92705																																																									
at&t 7701 VANCE STREET, SUITE 1000 DALLAS, TEXAS 75237			<table border="1"> <tr> <th>NO.</th> <th>DATE</th> <th>BY</th> <th>CHK</th> <th>DESCRIPTION</th> </tr> <tr> <td>1</td> <td>10/10/10</td> <td>JK</td> <td>JK</td> <td>REVISED PER CITY COMMENTS &amp; PER DESIGN</td> </tr> <tr> <td>2</td> <td>10/10/10</td> <td>JK</td> <td>JK</td> <td>REVISED PER DESIGNER COMMENTS</td> </tr> <tr> <td>3</td> <td>10/10/10</td> <td>JK</td> <td>JK</td> <td>REVISED PER DESIGNER COMMENTS</td> </tr> <tr> <td>4</td> <td>10/10/10</td> <td>JK</td> <td>JK</td> <td>REVISED PER DESIGNER COMMENTS</td> </tr> <tr> <td>5</td> <td>10/10/10</td> <td>JK</td> <td>JK</td> <td>REVISED PER DESIGNER COMMENTS</td> </tr> <tr> <td>6</td> <td>10/10/10</td> <td>JK</td> <td>JK</td> <td>REVISED PER DESIGNER COMMENTS</td> </tr> <tr> <td>7</td> <td>10/10/10</td> <td>JK</td> <td>JK</td> <td>REVISED PER DESIGNER COMMENTS</td> </tr> <tr> <td>8</td> <td>10/10/10</td> <td>JK</td> <td>JK</td> <td>REVISED PER DESIGNER COMMENTS</td> </tr> <tr> <td>9</td> <td>10/10/10</td> <td>JK</td> <td>JK</td> <td>REVISED PER DESIGNER COMMENTS</td> </tr> <tr> <td>10</td> <td>10/10/10</td> <td>JK</td> <td>JK</td> <td>REVISED PER DESIGNER COMMENTS</td> </tr> </table>			NO.	DATE	BY	CHK	DESCRIPTION	1	10/10/10	JK	JK	REVISED PER CITY COMMENTS & PER DESIGN	2	10/10/10	JK	JK	REVISED PER DESIGNER COMMENTS	3	10/10/10	JK	JK	REVISED PER DESIGNER COMMENTS	4	10/10/10	JK	JK	REVISED PER DESIGNER COMMENTS	5	10/10/10	JK	JK	REVISED PER DESIGNER COMMENTS	6	10/10/10	JK	JK	REVISED PER DESIGNER COMMENTS	7	10/10/10	JK	JK	REVISED PER DESIGNER COMMENTS	8	10/10/10	JK	JK	REVISED PER DESIGNER COMMENTS	9	10/10/10	JK	JK	REVISED PER DESIGNER COMMENTS	10	10/10/10	JK	JK	REVISED PER DESIGNER COMMENTS
NO.	DATE	BY	CHK	DESCRIPTION																																																								
1	10/10/10	JK	JK	REVISED PER CITY COMMENTS & PER DESIGN																																																								
2	10/10/10	JK	JK	REVISED PER DESIGNER COMMENTS																																																								
3	10/10/10	JK	JK	REVISED PER DESIGNER COMMENTS																																																								
4	10/10/10	JK	JK	REVISED PER DESIGNER COMMENTS																																																								
5	10/10/10	JK	JK	REVISED PER DESIGNER COMMENTS																																																								
6	10/10/10	JK	JK	REVISED PER DESIGNER COMMENTS																																																								
7	10/10/10	JK	JK	REVISED PER DESIGNER COMMENTS																																																								
8	10/10/10	JK	JK	REVISED PER DESIGNER COMMENTS																																																								
9	10/10/10	JK	JK	REVISED PER DESIGNER COMMENTS																																																								
10	10/10/10	JK	JK	REVISED PER DESIGNER COMMENTS																																																								



VICINITY MAP  
(SCALE FOR TITLE)



OVERALL SITE PLAN  
(SCALE: 1" = 20'-0")

**LEGEND**  
These standard symbols are to be found in the drawing

- 1000 MARKERS
- 2000 MARKERS
- 3000 MARKERS
- 4000 MARKERS
- 5000 MARKERS
- 6000 MARKERS
- 7000 MARKERS
- 8000 MARKERS
- 9000 MARKERS
- 10000 MARKERS
- 11000 MARKERS
- 12000 MARKERS
- 13000 MARKERS
- 14000 MARKERS
- 15000 MARKERS
- 16000 MARKERS
- 17000 MARKERS
- 18000 MARKERS
- 19000 MARKERS
- 20000 MARKERS
- 21000 MARKERS
- 22000 MARKERS
- 23000 MARKERS
- 24000 MARKERS
- 25000 MARKERS
- 26000 MARKERS
- 27000 MARKERS
- 28000 MARKERS
- 29000 MARKERS
- 30000 MARKERS
- 31000 MARKERS
- 32000 MARKERS
- 33000 MARKERS
- 34000 MARKERS
- 35000 MARKERS
- 36000 MARKERS
- 37000 MARKERS
- 38000 MARKERS
- 39000 MARKERS
- 40000 MARKERS
- 41000 MARKERS
- 42000 MARKERS
- 43000 MARKERS
- 44000 MARKERS
- 45000 MARKERS
- 46000 MARKERS
- 47000 MARKERS
- 48000 MARKERS
- 49000 MARKERS
- 50000 MARKERS
- 51000 MARKERS
- 52000 MARKERS
- 53000 MARKERS
- 54000 MARKERS
- 55000 MARKERS
- 56000 MARKERS
- 57000 MARKERS
- 58000 MARKERS
- 59000 MARKERS
- 60000 MARKERS
- 61000 MARKERS
- 62000 MARKERS
- 63000 MARKERS
- 64000 MARKERS
- 65000 MARKERS
- 66000 MARKERS
- 67000 MARKERS
- 68000 MARKERS
- 69000 MARKERS
- 70000 MARKERS
- 71000 MARKERS
- 72000 MARKERS
- 73000 MARKERS
- 74000 MARKERS
- 75000 MARKERS
- 76000 MARKERS
- 77000 MARKERS
- 78000 MARKERS
- 79000 MARKERS
- 80000 MARKERS
- 81000 MARKERS
- 82000 MARKERS
- 83000 MARKERS
- 84000 MARKERS
- 85000 MARKERS
- 86000 MARKERS
- 87000 MARKERS
- 88000 MARKERS
- 89000 MARKERS
- 90000 MARKERS
- 91000 MARKERS
- 92000 MARKERS
- 93000 MARKERS
- 94000 MARKERS
- 95000 MARKERS
- 96000 MARKERS
- 97000 MARKERS
- 98000 MARKERS
- 99000 MARKERS
- 100000 MARKERS

**LEGEND**  
1) This is not a boundary survey. This is a recorded map of the property and the boundaries shown are from record information as such. Floyd Surveying and Mapping, Inc. is not responsible for the accuracy of the information shown in this report. The information shown is for informational purposes only.  
2) Any boundary lines in this information are shown on the plan, subject to the actual survey of the property.  
3) These drawings & specifications are the property of the engineer & are not to be used for any other purpose without the written consent of the engineer.  
4) Field survey completed on SEPTEMBER 27, 2018.

**GENERAL NOTES**  
SCALE: 1" = 20'-0"  
SHEET NO.: B01  
TOPOGRAPHIC SURVEY  
DATE: 10/15/18  
DRAWN BY: J. B. [unclear]  
CHECKED BY: [unclear]  
APPROVED BY: [unclear]

**TITLE REPORT NOTES**  
OWNER'S NAME: OCEAN TERRACE  
ASSESSOR'S PARCEL NUMBER(S): 774-071-01-03  
DATE OF RECORD: (MIRIAM; BOOK 2003)  
THE RECORDS SHOW MIRIAM AND OCEAN TERRACE STATE PLATE COMMUNITY TRUST - 1998, & IS ESTABLISHED BY CP 2 RECORDS, RECORD 125 2878968.  
BASE OF ELEVATIONS: MVD 108  
ELEVATIONS ARE BASED ON GPS OBSERVATIONS FROM TWO NATIONAL MONUMENTS: 652318 AND 21 P.M.N. ELEVATION = 37.07' WITH GPS 2013 CORRECTIONS ADDED.  
**SITE DATA**  
SITE: 201 LOMAS SANTA FE DRIVE, LOMAS SANTA FE, CA 92025  
Map/Parcel: 652318022  
Effective Date: 2/7/2012  
The Flood Zone Designation for this site is: 209, X

**FEMA FLOOD ZONE INFORMATION**

FLOOD ZONE	DATE	REVISION	BY	DATE
209	02/07/12	1	J.B.	02/07/12
209	02/07/12	2	J.B.	02/07/12
209	02/07/12	3	J.B.	02/07/12
209	02/07/12	4	J.B.	02/07/12
209	02/07/12	5	J.B.	02/07/12
209	02/07/12	6	J.B.	02/07/12
209	02/07/12	7	J.B.	02/07/12
209	02/07/12	8	J.B.	02/07/12
209	02/07/12	9	J.B.	02/07/12
209	02/07/12	10	J.B.	02/07/12
209	02/07/12	11	J.B.	02/07/12
209	02/07/12	12	J.B.	02/07/12
209	02/07/12	13	J.B.	02/07/12
209	02/07/12	14	J.B.	02/07/12
209	02/07/12	15	J.B.	02/07/12
209	02/07/12	16	J.B.	02/07/12
209	02/07/12	17	J.B.	02/07/12
209	02/07/12	18	J.B.	02/07/12
209	02/07/12	19	J.B.	02/07/12
209	02/07/12	20	J.B.	02/07/12
209	02/07/12	21	J.B.	02/07/12
209	02/07/12	22	J.B.	02/07/12
209	02/07/12	23	J.B.	02/07/12
209	02/07/12	24	J.B.	02/07/12
209	02/07/12	25	J.B.	02/07/12
209	02/07/12	26	J.B.	02/07/12
209	02/07/12	27	J.B.	02/07/12
209	02/07/12	28	J.B.	02/07/12
209	02/07/12	29	J.B.	02/07/12
209	02/07/12	30	J.B.	02/07/12
209	02/07/12	31	J.B.	02/07/12
209	02/07/12	32	J.B.	02/07/12
209	02/07/12	33	J.B.	02/07/12
209	02/07/12	34	J.B.	02/07/12
209	02/07/12	35	J.B.	02/07/12
209	02/07/12	36	J.B.	02/07/12
209	02/07/12	37	J.B.	02/07/12
209	02/07/12	38	J.B.	02/07/12
209	02/07/12	39	J.B.	02/07/12
209	02/07/12	40	J.B.	02/07/12
209	02/07/12	41	J.B.	02/07/12
209	02/07/12	42	J.B.	02/07/12
209	02/07/12	43	J.B.	02/07/12
209	02/07/12	44	J.B.	02/07/12
209	02/07/12	45	J.B.	02/07/12
209	02/07/12	46	J.B.	02/07/12
209	02/07/12	47	J.B.	02/07/12
209	02/07/12	48	J.B.	02/07/12
209	02/07/12	49	J.B.	02/07/12
209	02/07/12	50	J.B.	02/07/12

**PROPERTY LEGAL DESCRIPTION**  
FLOYD SURVEYING  
3400 CALIFORNIA STREET  
THOUSAND OAKS, CA 91320  
PHONE: (805) 455-1000 FAX: (805) 455-1001  
EMAIL: floyd@floyd-surveying.com

**DCI PACIFIC A/E/C WORKS**  
ARCHITECTURE-ENGINEERING-CONSULTING  
12 EXECUTIVE PARK, SUITE 100, RIVIERE, CA 92081  
PHONE: (949) 415-1000 FAX: (949) 415-1001

**LOMAS SANTA FE SDO0925**  
201 LOMAS SANTA FE DRIVE  
SOLANA BEACH, CA 92025

**at&t**  
11777 PACIFIC STREET  
SAN DIEGO, CA 92103



## WIRELESS PLANNING MEMORANDUM

**TO:** Corey Andrews  
**FROM:** Michael D. Johnston  
**REVIEWERS:** Dr. Jonathan L. Kramer, Robert C. May  
**DATE:** May 4, 2017

**RE: 17-17-15: Technical Review for New Building Mounted  
Wireless Facility**

**Applicant:** AT&T Mobility  
**Site Address:** 201 Lomas Santa Fe Drive  
**Site ID:** Lomas Santa Fe

The City of Solana Beach (the “City”) requested a review of the AT&T Mobility (“AT&T”) proposal to construct and operate a new wireless site mounted on the building at 201 Lomas Santa Fe Drive. This memorandum addresses the following questions: (1) whether Section 6409(a) applies to AT&T’s proposal; (2) whether AT&T’s proposal complies with the Solana Beach Municipal Code and City Council Policy No. 21; (3) whether potential alternatives exist that deserve additional consideration; and (4) whether AT&T’s proposal demonstrates planned compliance with the federal radio frequency exposure guidelines.

This memorandum reviews the application and related materials for technical and regulatory issues specific to wireless infrastructure. Although many technical issues implicate legal issues, the analysis and recommendations contained in this memorandum do not constitute legal advice.

### 1. Project Description

AT&T proposes to construct a new wireless facility on an office building located in the Office Professional (“OP”) zone. This project is a relocation from an existing site that is being decommissioned due an expired lease with the current property owner. AT&T’s project plans dated March 20, 2017 (the “Plans”) and submitted with this application show that the facility would be concealed behind fiber-reinforced plastic (“FRP”) screens painted and textured to match the underlying building. AT&T would install twelve panel antennas evenly distributed in four sectors center-mounted at 53.5’ above ground level (“AGL”).

Behind the antennas, AT&T proposes to install eight remote radio units (“RRUs”) in each sector for a total of 32 RRUs, six DC power surge protectors (“Raycaps”) and two GPS

antennas. The Plans depict that all the antennas and associated equipment will be fully concealed behind the FRP screens, which would measure 8' by 10' 9" and would protrude from the existing building by 1' 6".

At ground level adjacent to the building entrance stairs, AT&T proposes to remove a portion of an existing 5.5' tall retaining wall, remove some of the existing landscaping and an existing diseased tree in order to install a new 8' tall concrete masonry unit ("CMU") wall. AT&T would construct new stairs, a new landing and plant new landscaping to replace the diseased tree. Within the CMU wall enclosure, AT&T proposes to install four stack-mounted radio equipment cabinets, one power cabinet, one battery cabinet, and telephone and electric utility panels all on a concrete slab foundation. The CMU wall enclosure would be painted to match the existing surrounding and fully enclosed on top with a new steel grate lid.

In accordance with discussions between the City and AT&T that occurred during a November 2016 pre-application meeting for this project, AT&T also proposes to improve the sidewalk, road and landscaping along the eastern property line at Granados Avenue.

## 2. Section 6409(a) Analysis

As a threshold matter, the City must determine whether federal law mandates approval for this permit application. Section 6409(a) of the Middle Class Tax Relief and Job Creation Act of 2012 requires that State and local governments "may not deny, and shall approve" any "eligible facilities request" for a wireless site collocation or modification so long as it does not cause a "substant[ial] change in [that site's] physical dimensions."<sup>1</sup> FCC regulations interpret key terms in this statute and impose certain substantive and procedural limitations on local review.<sup>2</sup> Localities must review applications submitted for approval pursuant to Section 6409(a), but the applicant bears the burden to show it qualifies for mandatory approval.

Section 6409(a)(2) defines an "eligible facilities request" as a request to collocate, remove or replace transmission equipment on an existing wireless tower or base station.<sup>3</sup> This definition necessarily excludes permit requests for new facilities. Thus, no matter how large or small, Section 6409(a) does not mandate approval for a permit to construct an entirely new wireless facility.

Here, AT&T did not submit an eligible facilities request because rather than collocate on an existing facility, AT&T proposes to construct a new wireless facility where none currently exists. Accordingly, Section 6409(a) does not require that the City approve AT&T's application. Rather, the City should review AT&T's proposal for compliance with

<sup>1</sup> See Section 6409(a) of the Middle Class Tax Relief and Job Creation Act of 2012, Pub. L. No. 112-96, 126 Stat. 156. (Feb. 22, 2012) (codified as 47 U.S.C. § 1455(a)).

<sup>2</sup> See In the Matter of Acceleration of Broadband Deployment by Improving Wireless Facilities Siting Policies, *Report and Order*, 29 FCC Rcd. 12864 (Oct. 17, 2014) (codified as 47 C.F.R. §§ 1.40001, *et seq.*).

<sup>3</sup> See 47 U.S.C. § 1455(a)(2).

{00009926:2}



Telecom Law Firm PC

the local values expressed in the Solana Beach Municipal Code ("**SBMC**") and City Council Policy No. 21 ("**Council Policy No. 21**") subject to certain federal limitations in Section 704 of the Telecommunications Act of 1996 (the "**Telecom Act**").

### 3. Compliance with Solana Beach Municipal Code and City Council Policy No. 21

The City requires a conditional use permit for all wireless facilities, which must comply with Council Policy No. 21.<sup>4</sup> Council Policy No. 21 provides general location and design guidelines for new wireless facilities as discussed below.

#### 3.1. Proposed Location

Council Policy No. 21 establishes hierarchical preferences for site locations as follows in order of preference and in relevant part: (1) collocations in non-residential zones; (2) industrial zones; (3) commercial zones; (4) other non-residential zones except open space.<sup>5</sup> Wireless facilities should be located in areas that are least visible to the public and least disruptive to the underlying property.<sup>6</sup> If the proposed location is visible to a residential area, the facility must be architecturally integrated with the surrounding site.<sup>7</sup> Here, AT&T proposes to construct the site in the fourth-most preferred location category. Even though Council Policy No. 21 does not expressly account for the OP zone, the catch-all in the fourth preference includes the proposed location because the OP zone is a non-residential and non-open space zone.

However, other potential locations around the proposed site rank higher under Council Policy No. 21 and the City may wish to consider the following locations as potential alternative locations that are more-preferred:

- 210 Lomas Santa Fe Dr. (Light Commercial)
- 124 Lomas Santa Fe Dr. (Special Commercial)
- 100/125 Lomas Santa Fe Dr. (Special Commercial)

In addition, to the extent that nearby wireless facilities already exist, the City may also wish to request that AT&T provide a list of sites that provide potential collocation opportunities.

To determine whether these more preferred locations are potentially available and technically feasible, the City may wish to request that AT&T provide a meaningful comparative analysis for each location that addresses (1) what general site parameters AT&T believes it would need to achieve reasonably similar service improvement as compared to the proposed location, (2) whether and under what general circumstances

---

<sup>4</sup> See SOLANA BEACH MUN. CODE §17.60.120.G(1)

<sup>5</sup> See Council Policy No. 21 § A.1.

<sup>6</sup> See *id.* § A.3.

<sup>7</sup> See *id.*

{00009926;2}





AT&T could obtain access to these locations and (3) any other information AT&T believes would assist the City to compare the proposed location against the potential alternatives.

### 3.2. Proposed Design

Council Policy No. 21 requires that all wireless facilities must exhibit stealth design techniques that conceal the equipment and visually blend with support structure and natural or manmade environment. Applicants should place equipment within existing buildings, and new shelters or enclosures should mimic existing architecture and landscaping. Roof mounted antennas should not be placed on roof peaks.<sup>8</sup>

Here, the proposed design generally conforms to most design guidelines in Council Policy No. 21, but the City may wish to consider some modifications to promote compliance with the guidelines. The following list outlines some issues and potential solutions for the City to consider:

- **Antenna Equipment and Architectural Screening**

AT&T would install the transmission equipment behind FRP screens that generally integrate with the existing architecture. However, AT&T's photo simulations depict a minor inconsistency between the proposed architectural screening and the underlying building. Rather than maintain the white paint along the level of the building with the "Wedbush" sign, AT&T would paint the entire screening grey.

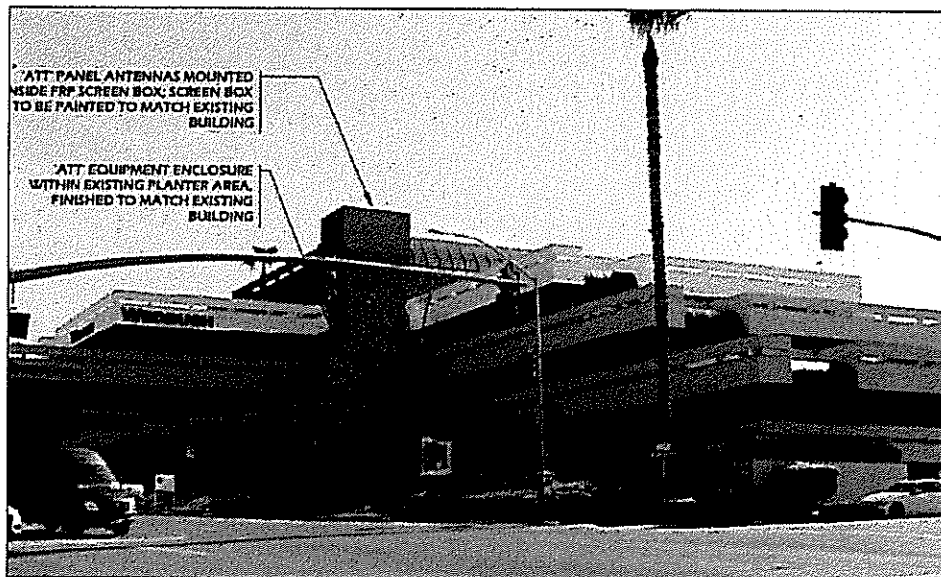


Figure 1: AT&T's Photo Simulations (Source: DCI Pacific AEC Works)

<sup>8</sup> See *id.*, § B.6.b.

{00009926:2}



Accordingly, the City may wish to consider the following conditions of approval in the event that the City approves AT&T's application in concept:

1. The permittee shall, and at all times maintain in good condition, architectural screening that is painted and textured to match the colors and textures of the underlying support structure.
2. The permittee acknowledges and agrees that the scale and proportionality of the architectural screening used to conceal and integrate the permittee's wireless facility with the underlying support structure constitutes concealment elements that are a material consideration upon which the City bases its decision to approve the permittee's facility.

- **Equipment Enclosure Concealment**

Council Policy No. 21 requires all enclosures to be located within existing buildings to the extent feasible.<sup>9</sup> To the extent the equipment must be located outside, the enclosure must mimic the existing manmade and natural features at the subject property.<sup>10</sup>

Here, AT&T proposes to install a new equipment enclosure outside the building. Accordingly, the City may wish to request that AT&T address whether locating the equipment within the existing building would be feasible. To the extent that an interior equipment room is not available for AT&T's use, the Plans indicate that the equipment enclosure will match the existing architecture and building finishes as required by Council Policy No. 21.

- **GPS Antennas**

AT&T indicates that it would install two GPS antennas on title sheet T01 of the Plans, but does not sheet A02 only shows one GPS antenna. The City may wish to request that AT&T resolve this discrepancy in the Plans and consider the following condition of approval to ensure that such equipment is fully concealed from public view:

3. The permittee shall install, and at times maintain in good condition, all equipment, including without limitation antennas, remote radio units, power surge suppressors, GPS antennas, equipment cabinets, power cabinets, battery cabinets and utility panels, fully concealed from public view within FRP screening or the CMU wall enclosure, as applicable.

---

<sup>9</sup> See *id.* § B.2.

<sup>10</sup> See *id.*

{00009926:2}



#### 4. Planned Compliance with RF Exposure Regulations

Under the Telecom Act, the FCC completely occupies the field with respect to RF emissions regulation. The FCC established comprehensive rules for human exposure to RF emissions (the "FCC Guidelines").<sup>11</sup> State and local governments cannot regulate wireless facilities based on environmental effects from RF emissions to the extent that the emissions comply with the FCC Guidelines.<sup>12</sup>

Although localities cannot establish their own standards for RF exposure, local officials may require wireless applicants to demonstrate compliance with the FCC Guidelines.<sup>13</sup> Such demonstrations usually involve a predictive calculation because the site has not yet been built.

##### 4.1. FCC Guidelines, Categorical Exclusions and Exposure Mitigation Measures

FCC Guidelines regulate *exposure* rather than *emissions*.<sup>14</sup> Although the FCC establishes a maximum permissible exposure ("MPE") limit, it does not mandate any specific limitations on power levels applicable to all antennas and requires the antenna operator to adopt exposure-mitigation measures only to the extent that certain persons might become exposed to the emissions. Thus, a relatively low-powered site in proximity to the general population might require more comprehensive mitigation measures than a relatively high-powered site in a remote location accessible only to trained personnel.

The MPE limit also differentiates between "general population" and "occupational" people. Most people fall into the general population class, which includes anyone who either does not know about potential exposure or knows about the exposure but cannot exert control over the transmitters.<sup>15</sup> The narrower occupational class includes persons exposed through their employment and able to exert control over their exposure.<sup>16</sup> The MPE limit for the general population is five times lower than the MPE limit for the occupational class.

Lastly, the FCC "categorically excludes" certain antennas from routine environmental review when either (1) the antennas create exposures in areas virtually inaccessible to

---

<sup>11</sup> See 47 U.S.C. § 332(c)(7)(B)(iv); see also 47 C.F.R. § 1.1307 *et seq.*; FCC Office of Engineering and Technology, *Evaluating Compliance with FCC Guidelines for Human Exposure to Radiofrequency Electromagnetic Fields*, OET Bulletin 65, ed. 97-01 (1997).

<sup>12</sup> See 47 U.S.C. § 332(c)(7)(B)(iv).

<sup>13</sup> See *In re Procedures for Reviewing Requests for Relief from State and Local Regulations Pursuant to Section 332(c)(7)(B)(iv) of the Communications Act of 1934*, *Report and Order*, 15 FCC Rcd. 22821, 22828–22829 (Nov. 13, 2000) (declining to adopt rules that limit local authority to require compliance demonstrations).

<sup>14</sup> See *generally* Human Exposure to Radio Frequency Fields: Guidelines for Cellular and PCS Sites, *Consumer Guide*, FCC (Oct. 22, 2014), available at <https://www.fcc.gov/guides/human-exposure-rf-fields-guidelines-cellular-and-pcs-sites> (discussing in general terms how wireless sites transmit and how the FCC regulates the emissions).

<sup>15</sup> See 47 C.F.R. § 1.1310, Note 2.

<sup>16</sup> See *id.*



humans or (2) the antennas operate at extreme low power. As a general rule, a wireless site qualified for a categorical exclusion when mounted on a structure built solely or primarily to support FCC-licensed or authorized equipment (*i.e.*, a tower) and such that the lowest point on the lowest transmitter is more than 10 meters (32.8 feet) above ground.<sup>17</sup>

Categorical exclusions establish a presumption that the emissions from the antennas will not significantly impact humans or the human environment. Such antennas are exempt from routine compliance evaluations but not exempt from actual compliance. Under some circumstances, such as a heavily collocated tower or when in close proximity to general population members, even a categorically excluded site will require additional analysis.

#### 4.2. Planned Compliance Evaluation and Recommendations

The FCC Guidelines do not categorically exclude AT&T's proposal because AT&T proposes to mount the antennas on an office building that was constructed for commercial use rather than to support wireless antennas. Accordingly, an independent RF compliance evaluation would be appropriate.

Here, AT&T submitted a *Radio Frequency Safety Survey Report Prediction* prepared by Waterford Consultants, LLC dated March 30, 2017 (the "**Waterford Report**"). Based on a computer-simulated analysis, the Waterford Report finds that the RF exposure from the AT&T antennas will exceed the maximum limit for the general population in some areas on the rooftop, but that AT&T can demonstrate planned compliance through appropriate mitigation measures.

The Waterford Report contains the basic RF emissions data needed to independently evaluate planned compliance. Based on the power output levels and operating frequencies for sectors A, C and D, AT&T's transmitters would create a controlled access zone that extends approximately 34' horizontally from the face of the antennas, at approximately 53' AGL, with few stray emissions in any other direction. Based on the power output levels and operating frequencies for sector B, AT&T's transmitters would create a controlled access zone that extends approximately 50.3'.

A controlled access zone does not mean that the facility will not comply with the FCC Guidelines. In this case, the controlled access zones would extend into generally accessible areas in all sectors under fairly limited circumstances. For instance, maintenance workers and painting crews that access the rooftop to service mechanical equipment and/or paint the building exterior could potentially be unknowingly overexposed to RF emissions because the antennas are fully concealed from view, and in Sector A, the controlled zone extends across an accessible rooftop area.

---

<sup>17</sup> See *id.* § 1.1307(b)(1).



Accordingly, AT&T must take affirmative steps to post notice near, and in some cases restrict access to, the adjacent areas on the rooftop or building where the exposure exceeds the FCC's limits. Consistent with the Waterford Report, the City should require AT&T to erect a barrier and place signage on a portion of the upper level rooftop, as depicted below in Figure 3. However, in contrast to the recommendation in the Waterford Report, the City should require a larger restricted access area to encompass the entire controlled access zone. Figure 2 depicts the controlled access zone in the Waterford Report. Figure 3 depicts the boundaries of the controlled access zone as calculated by this firm based on a worst-case scenario.

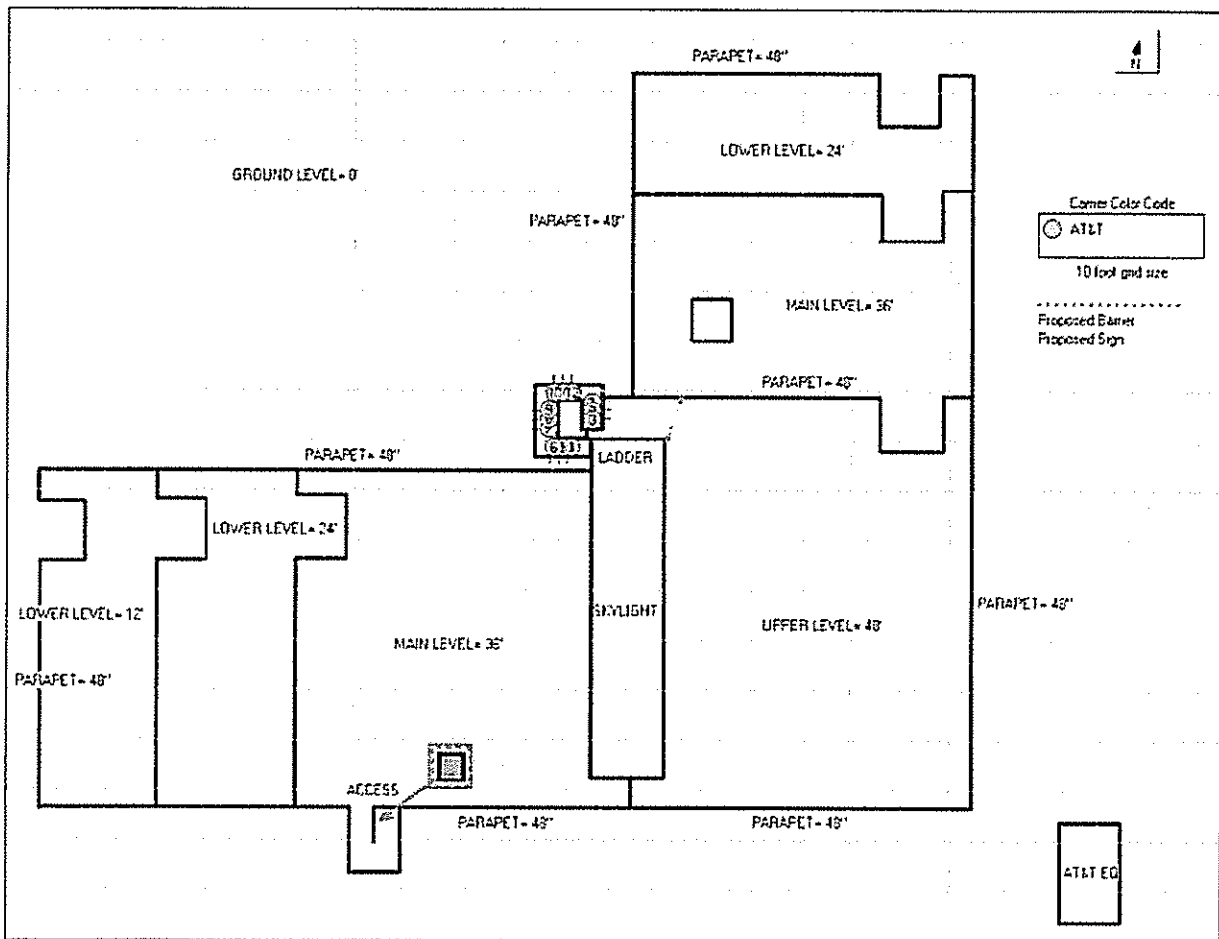


Figure 2: Proposed restricted access zone depicted in dotted orange line (Source: Waterford Report).

[Balance of page intentionally left blank]

{00009926:2}



Telecom Law Firm PC



Figure 3: Restricted access zone, depicted in solid red line (Source: Google maps, annotated by M. Johnston).

In the event that the City approves AT&T's application in its current form and to promote compliance with the FCC Guidelines, the City may wish to consider the following conditions of approval related to routine access restrictions and signage protocols as potential mitigation measures:

1. The permittee shall keep all access points to the rooftop locked at all times except when active maintenance is performed on the rooftop.

{00009926:2}



Telecom Law Firm PC

2. The permittee shall install, and at all times maintain in good condition, an "RF Information" sign at all rooftop access point(s). Permittee shall install the signs required under this condition so that a person may clearly see and understand the sign before he or she accesses the rooftop.
3. The permittee shall install, and at all times maintain in good condition, a polyurethane chain link barrier approximately 34 feet from the face of the antennas in sector A that extends from the north parapet wall to the sky light. The permittee shall also install, and at all times maintain in good condition, an "RF Caution" sign on the chain link barrier in front of sector A. The permittee shall install the sign required under this condition so that a person may clearly see and understand the sign as he or she approaches the control access zone for sector A.
4. The permittee shall install and at all times maintain in good condition, an "RF Caution" sign adjacent to the access ladder between sector A and sector B. The permittee shall install the sign required under this condition so that a person may clearly see and understand the sign as he or she approaches the access ladder.
5. The permittee shall ensure that all signage complies with FCC OET Bulletin 65 or ANSI C95.2 for color, symbol, and content conventions. All such signage shall at all times provide a working local or toll-free telephone number to its network operations center, and such telephone number shall be able to reach a live person who can exert transmitter power-down control over this site as required by the FCC.

## 5. Conclusion

AT&T's application materials do not contain all the information needed to determine whether the proposed location for AT&T's new wireless facility most closely complies with the City's preferences under Council Policy No. 21. Accordingly, the City should consider requesting that AT&T submit addition information that evaluates locations in the three more preferred locations as described in Section 3.1 of this memorandum.

In the event that no more preferred location that is potentially available and technically feasible exists, the City may wish to consider approving AT&T's proposed facility subject to the recommended conditions of approval in Section 3.2 of this memorandum.

In the event that the City approves AT&T's application in the same antenna configuration as proposed, the facility can demonstrate planned compliance with the FCC Guidelines related to RF exposure subject to the recommended conditions of approval in Section 4.2 of this memorandum.

MJ/jlk/rm

{00009926:2}



Telecom Law Firm PC

## WIRELESS PLANNING MEMORANDUM

**TO:** Corey Andrews  
**FROM:** Robert C. May III  
**DATE:** August 30, 2017

**RE:** **17-17-15: Technical Review of Conditional Use Permit and Structure Development Permit Application**

**Applicant:** AT&T Mobility  
**Site Address:** 201 Lomas Santa Fe Drive, Solana Beach, California 92075  
**Site ID:** SD0925

The City of Solana Beach (the "City") requested that Telecom Law Firm, PC review the AT&T Mobility ("AT&T") application to relocate an existing wireless site to a new location at 201 Lomas Santa Fe Drive. This memorandum reviews the application and related materials for technical and regulatory issues specific to wireless infrastructure. Although many technical issues may implicate legal and/or regulatory issues, the analysis and recommendations contained in this memorandum do not constitute legal advice.

### 1. PROJECT BACKGROUND AND DESCRIPTION

This firm issued a memorandum dated May 4, 2017 (the "**May Memorandum**") to the City that evaluated AT&T's current proposal to relocate an existing wireless facility to a commercial office building located at 201 Lomas Santa Fe Drive (the "**Proposed Location**").<sup>1</sup> The May Memorandum concluded that AT&T should investigate whether three potential alternatives in more-preferred locations would be technically feasible or potentially available.

On or around July 30, 2017, AT&T provided an alternative sites analysis dated May 2017 (the "**May 2017 Alternatives Analysis**"). The City subsequently requested an independent evaluation from this firm.

### 2. TECHNICAL FEASIBILITY OF POTENTIAL ALTERNATIVE SITES

The May 2017 Alternatives Analysis evaluates four possible alternatives: (1) no relocated site at all; (2) a new site located at 210 Lomas Santa Fe Drive; (3) a new site located at 124 Lomas Santa Fe Drive; and (4) a new site located at 100 Lomas Santa Fe Drive. In light of the propagation map that AT&T provided to show predicted service levels at the

---

<sup>1</sup> See Memorandum from Michael D. Johnston, Telecom Law Firm, PC, to Corey Andrews, Principal Planner, Solana Beach, Cal. (May 4, 2017).



Proposed Location as shown in **Figure 1**, the following discussion evaluates AT&T's supplemental alternative sites analysis and offers additional recommendations.

As a threshold matter, the City should note that the signal propagation maps provided by AT&T contains subjective characterizations rather than objective service levels. This practice limits the City's ability to meaningfully compare various alternatives because the City cannot determine whether AT&T's opinion about whether particular services are "good" or "bad" meet generally accepted benchmarks. These propagation maps are generally less reliable for the same reason.

For the present purposes only, the evaluation and analysis in this memorandum will assume that the various characterizations roughly translate to generally accepted benchmarks ("good" = -75 dBm; "fair" = -85 dBm; and "bad" = -95 dBm). However, to the extent that the City and AT&T disagree about the technical feasibility for any particular alternative, the City may wish to consider requiring AT&T to perform an empirical drive test that would definitely show actual differences in service levels from one or more alternative sites as compared to the Proposed Location.

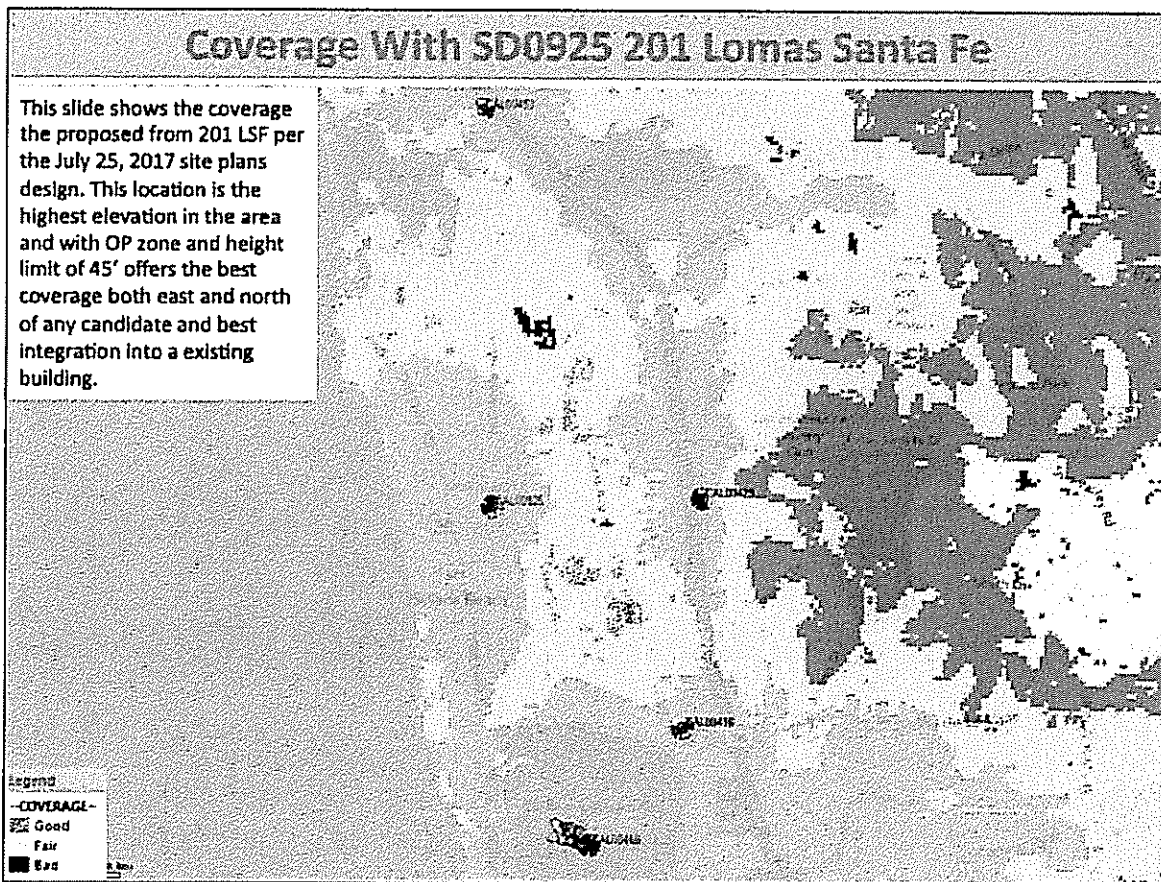


Figure 1: (Source: AT&T.)



## 2.1. AT&T Alternative 1: No Relocated Site

AT&T provided a propagation map in **Figure 2** to show the predicted service levels if the City denied any relocation site. According to this propagation map, AT&T believes it would be limited to “bad” coverage in the areas along Highway 101 between San Elijo Lagoon to the north, Dahlia Drive to the south, the Pacific Ocean to the west and the ridgeline along Nardo Avenue below Lomas Santa Fe and Mar Vista above Lomas Santa Fe.

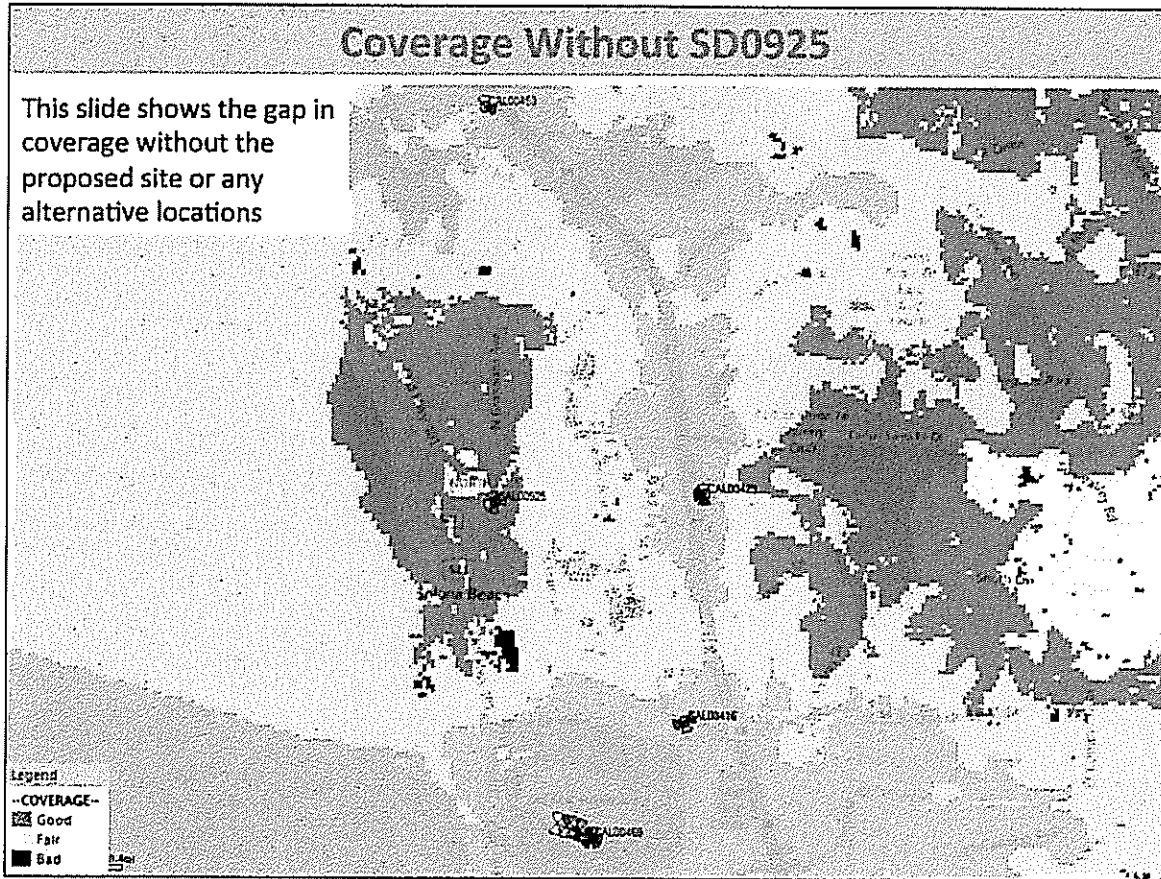


Figure 2: (Source: AT&T.)

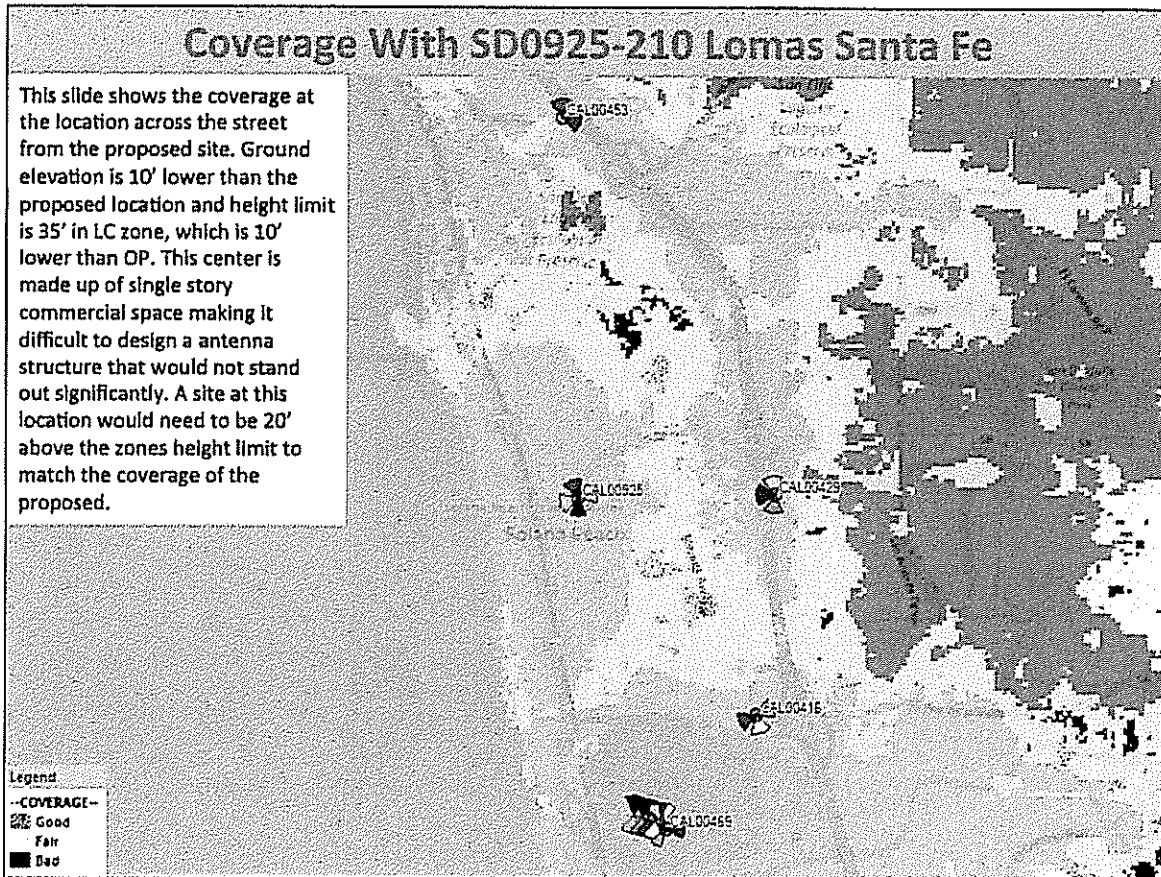
Whether the City accepts the propagation maps as valid or not, there seems to be little doubt that AT&T would experience a gap in its coverage if it decommissioned one site and did not replace it with another. Accordingly, the City should not consider this to be a technically feasible option.

## 2.2. AT&T Alternative 2: 210 Lomas Santa Fe Drive

AT&T notes that this location is approximately 10 feet lower in elevation and subject to 35-foot zone height limit, which would result in an antenna centerline approximately 20



feet lower than the Proposed Location. AT&T also comments that the existing commercial structure at this location is a single-story building with fewer concealment opportunities.



This alternative appears to be technically feasible as a single-site replacement. A comparison between the coverage achievable from this location and the coverage achievable from the Proposed Location shows little meaningful difference. Both sites would provide comparable "good" and "fair" coverage to roughly the same areas. Although a site at this alternative location would potentially be less optimal insofar as the "bad" coverage areas to the north would be slightly larger, those areas are generally open space or within the San Elijo Lagoon where users would typically be outdoors with fewer physical obstructions to attenuate the signal.

Moreover, the propagation map in **Figure 3** appears to show that the comparable coverage could be achieved without the additional 20-foot extension mentioned in AT&T's Alternatives Analysis. To be sure, the single-story, flat-roofed commercial building would present some concealment challenges. Possible designs might include, for example, a contiguous raised parapet around the entire rooftop or a freestanding architectural feature. However, even if the City ultimately prefers the design at the Proposed Location



over what could be built at 210 Lomas Santa Fe Drive, this alternative would still be potentially viable.

Accordingly, the City should consider a site at 210 Lomas Santa Fe as a possible alternative and should request that AT&T provide additional analysis into possible designs for this location.

### 2.3. AT&T Alternative 3: 124 Lomas Santa Fe Drive

AT&T notes that this location is approximately 30 feet lower in elevation and subject to 25-foot zone height limit, which would result in an antenna centerline approximately 50 feet lower than the Proposed Location. AT&T concludes that a site at this location would create a need for a second site to cover the area along Lomas Santa Fe between the freeway and Nardo Avenue.

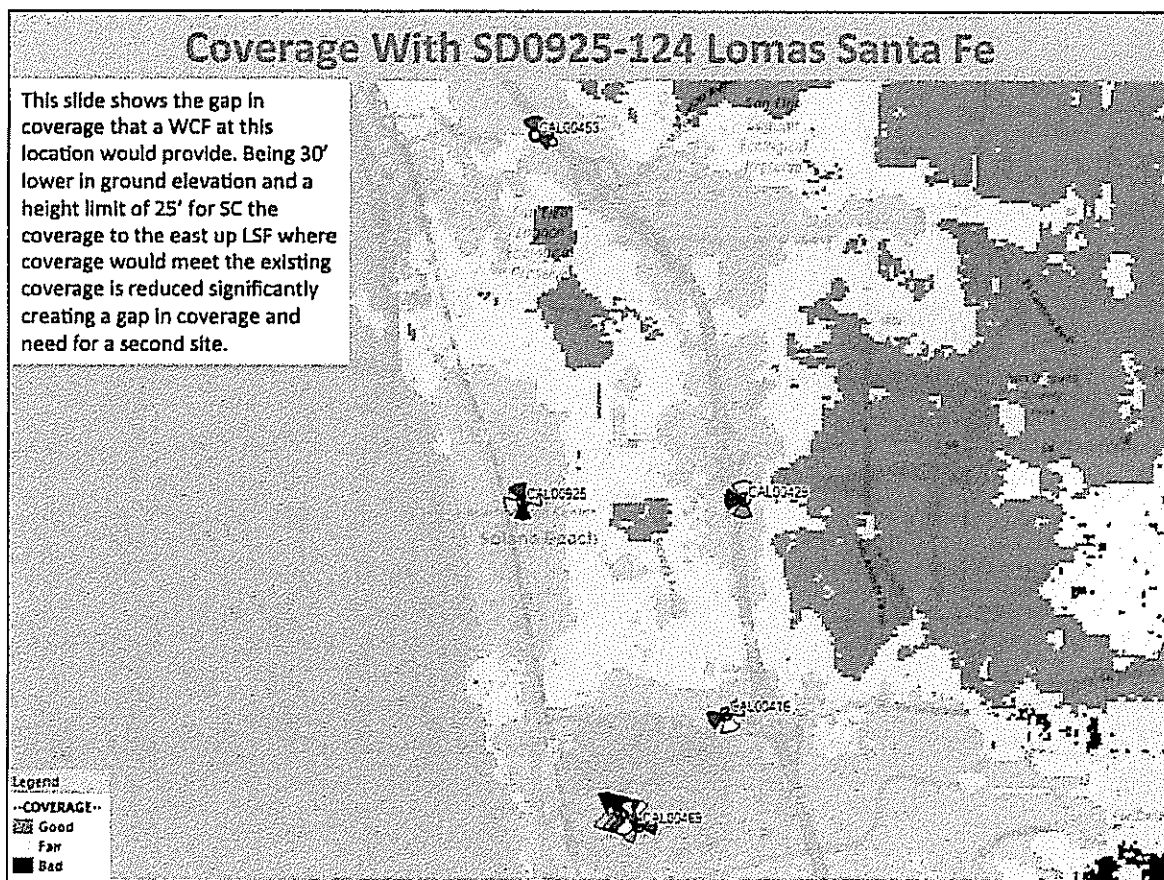


Figure 4: (Source: AT&T.)

Unlike the alternative at 210 Lomas Santa Fe Drive, this alternative appears to create the need for an additional site to provide supplemental coverage to the areas between Nardo Avenue and the freeway. Even if the propagation maps were disqualified as not reliable,



the 50-foot difference between antenna centerlines possible at this alternative and at the Proposed Location would have a significant impact on signal propagation.

Nevertheless, the City may wish to consider a multi-site solution with another site in a preferred zone. Some possible locations for the second site might be either (1) the Light Industrial parcels along Stevens Avenue West; (2) the Commercial parcels along San Rodolfo Drive; or (3) Solana Beach Presbyterian Church at 120 Stevens Avenue.

Accordingly, the City should consider a site at 124 Lomas Santa Fe as a possible alternative in a multi-site solution. If the City would consider a multi-site deployment, it should request that AT&T provide additional analysis into possible designs for the three locations listed above and any other possible alternatives.

#### **2.4. AT&T Alternative 4: 100 Lomas Santa Fe Drive**

AT&T notes that this location is approximately 40 feet lower in elevation and subject to 25-foot zone height limit, which would result in an antenna centerline approximately 60 feet lower than the Proposed Location. AT&T concludes that a site at this location would either need to be 60 feet above the zone height limit to achieve the same coverage as the Proposed Location, or create a need for a second site to cover the area along Lomas Santa Fe between the freeway and Nardo Avenue.

*[balance of page intentionally left blank]*



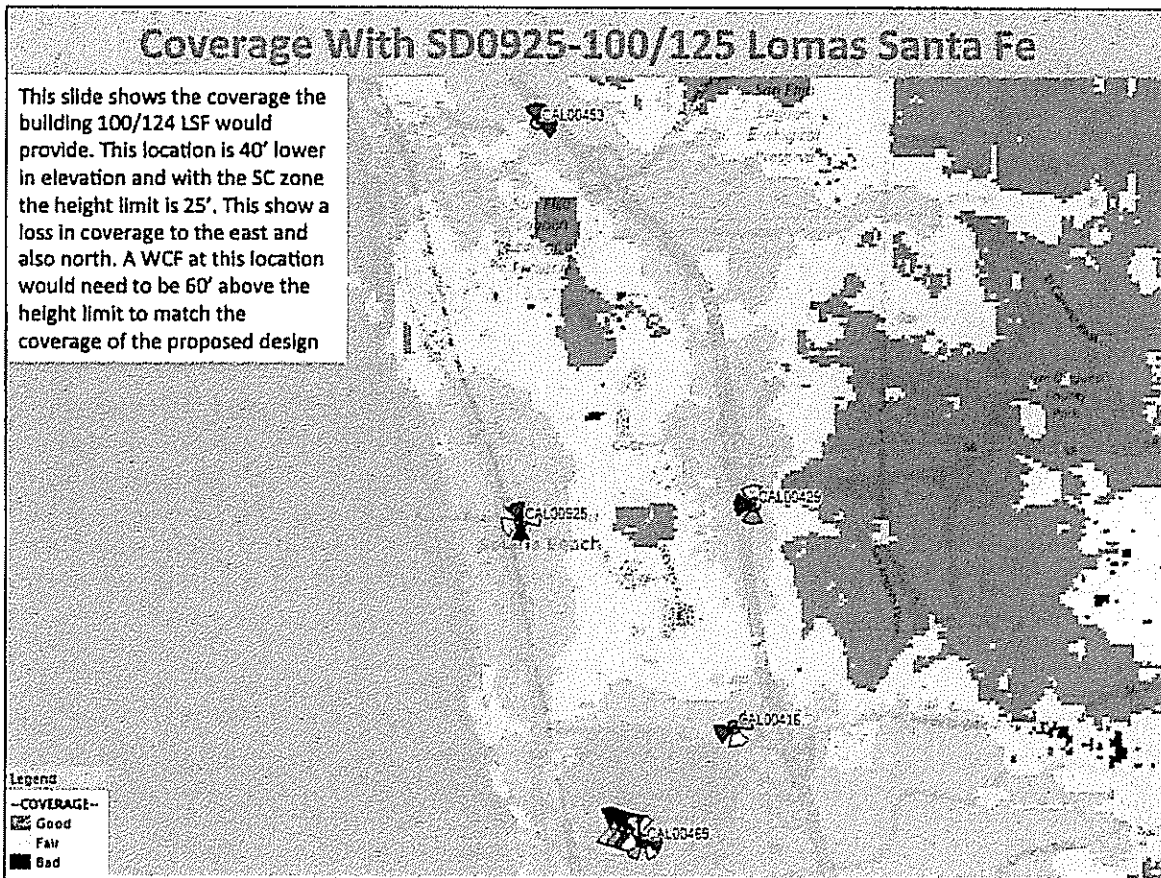


Figure 5: (Source: AT&T.)

Like the alternative at 124 Lomas Santa Fe Drive, this alternative does appear to create the need for an additional site to provide supplemental coverage to the areas between Nardo Avenue and the freeway. In addition, the propagation maps appear to show additional coverage degradation in the residential areas above Lomas Santa Fe Drive that was not present from an alternative at 124 Lomas Santa Fe Drive.

Although the City may wish to consider possible alternatives at those same locations around Stevens Avenue West or San Rodolfo Drive described in Section 2.3 of this memorandum, the more logical location to reach the northern areas would be the Solana Beach Presbyterian Church (120 Stevens Avenue). This alternative would provide AT&T with higher elevations and additional opportunities for concealment because of the variations in the architecture of the structures on the property.

Accordingly, the City should consider a site at 100 Lomas Santa Fe as a possible alternative in a multi-site solution. If the City would consider a multi-site deployment, it should request that AT&T provide additional analysis into possible designs for the Solana Beach Presbyterian Church and any other possible alternatives.





### 3. DESIGN ANALYSIS AND RECOMMENDATIONS

Based on the analysis above, it appears that the City may have at least two options for single-site solutions (the Proposed Location and 210 Lomas Santa Fe Drive) and potentially many options for a multi-site solution. Information available at this time suggests that all options may have some less-than-desirable trade-offs between location and possible concealment designs. Accordingly, this section evaluates the pros and cons among various alternatives to assist the City strike an appropriate balance that it finds most consistent with its local values expressed in the General Plan, the Solana Beach Municipal Code ("**SBMC**") and Council Policy No. 21.

Facilities must be compliant with the applicable zone development rules, and the applicable height limit for structures on this parcel is 45 feet.<sup>2</sup> Rooftop appurtenances in the OP zone must be screened from view from adjacent properties, public streets and on-site parking areas.<sup>3</sup> More specifically, wireless facilities must be screened from view with "stealth" techniques, such as false architectural elements, and rooftop sites should not be placed on rooftop peaks.<sup>4</sup> Ancillary wireless equipment must be located indoors to the extent feasible, or screened with walls, plants or other materials when such equipment must be placed outdoors.<sup>5</sup> The use must not produce any negative external effects, such as noise, odors, particulate matter, glare or electrical emissions that interfere with other lawfully operated equipment or instruments.<sup>6</sup>

#### 3.1. City Single Site Alternative 1: 210 Lomas Santa Fe Drive

Based on the information provided by AT&T, an alternative site located at 210 Lomas Santa Fe Drive appears to be technically feasible as single-site solution. Although the existing structure may not be as well-suited for concealment as the Proposed Location, the City could require AT&T to vet possible designs for both roof-mounted and freestanding facilities before this alternative is ruled out on aesthetic grounds.

Rooftop facilities might include a parapet wall extension with antennas distributed around the perimeter or a mechanical penthouse to house the antennas in a centralized location. The parapet wall extension would likely result in a cleaner design that maintains a consistent roofline, but would need to be approximately eight feet tall to conceal the antennas and would also add significant bulk to the building. A mechanical penthouse would obstruct a smaller area and add less overall bulk, but may seem out of place on this low, flat rooftop.

---

<sup>2</sup> See Council Policy No. 21 § B.4; SOLANA BEACH, CAL. MUN. CODE § 17.24.030(D).

<sup>3</sup> See SOLANA BEACH, CAL. MUN. CODE § 17.24.030(E)(2).

<sup>4</sup> See Council Policy No. 21 §§ B.1 and B.6.b.

<sup>5</sup> See *id.* § B.2.

<sup>6</sup> See SOLANA BEACH, CAL. MUN. CODE § 17.24.030(F); see *a/so* Council Policy No. 21 § C.1 (requiring compliance with generally applicable noise standards).



The most likely freestanding design that would blend with the existing environment would be a monument such as a clock tower or commercial sign. Although these approaches would leave the existing structure as-is and completely conceal all the proposed equipment, both types of structures may draw attention to themselves because they would be the tallest structures in the vicinity.

**Recommendation:** The City may wish to require that AT&T provide the City with conceptual-level drawings or renderings to give the City a sense about potential designs that can be compared to proposed design at the Proposed Location.

### **3.2. City Single Site Alternative 2: the Proposed Location**

The City may also wish to consider the Proposed Location, either as currently proposed or with alternative concealment.

#### ***Location Considerations***

The City could potentially find that the Proposed Location is equally preferable to the identified alternative locations. Whereas Council Policy No. 21 does not expressly rank its preference for facilities in OP zones, the OP zone could be fairly construed as a commercial zone given that permitted uses here include commercial uses and many similar passive operations are deemed either "permitted uses" or "conditionally permitted uses" under the SBMC.<sup>7</sup>

Moreover, while AT&T's proposal does not qualify as either a "minor utility project" or a "major utility project" under the SBMC,<sup>8</sup> major utility projects such as power plants and natural gas storage facilities would be considered a conditionally permitted use in this zone.<sup>9</sup> It is unlikely that an unmanned commercial wireless facility would have a greater adverse impact on community aesthetics or traffic circulation than a power plant or natural gas storage facility, and the City may find that a wireless facility in an OP zone would be comparably preferable to a wireless facility in a commercial zone.

#### ***Interactions between Overall Height and Concealment***

Due to the underlying structure's design and layout, there is a tradeoff between overall height and concealment. The most concealed design violates the zone height limit but the designs at lower overall heights would be closer and more visible to residential properties.

The overall height of AT&T's proposed facility would be approximately 64 feet above the lowest finished grade, which is the same overall height as the existing skylight on the

---

<sup>7</sup> See generally SOLANA BEACH, CAL. MUN. CODE § 17.12.020-A.

<sup>8</sup> See *id.* § 17.12.030, Appendix A (defining these terms).

<sup>9</sup> Compare *id.* § 17.12.020-A(27) (defining major public utility installations as a conditionally permitted use in the OP zone).

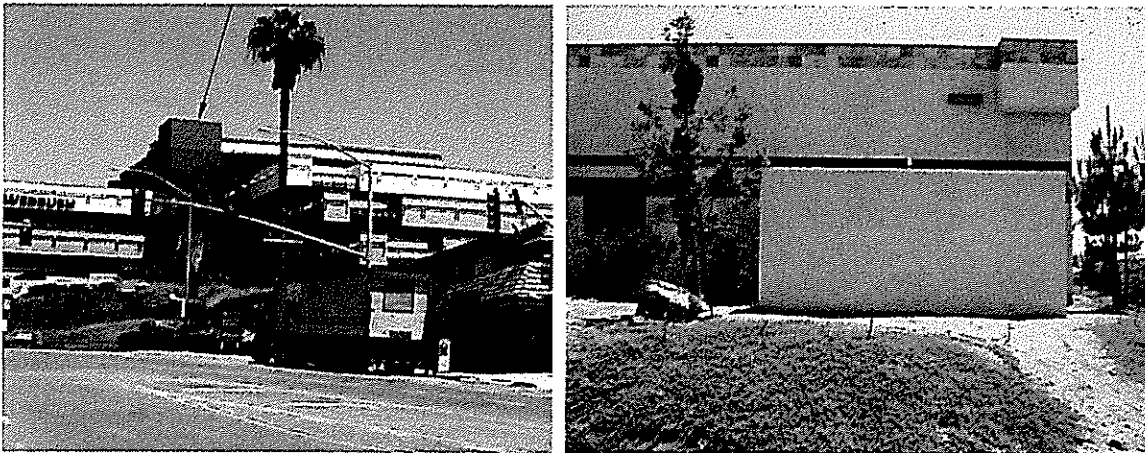




rooftop.<sup>10</sup> To reduce the overall height approximately 19 feet for compliance with the zone height limit would lower the antennas below the roofline. AT&T would then be required to split the sectors and mount the antennas in sectors A and B on the east-facing and south-facing facades.

AT&T's current single elevator-penthouse extension design appears more preferable to the lower height alternative because such an alternative would move the antennas in sectors A and B closer to residential uses and facade-mounted antennas would be less concealed. Whereas the antennas in the proposed design would be approximately 166 feet from the nearest residential use (122 South Rios Avenue), facade-mounted antennas in sector A would be approximately 116 feet from residences at 140 South Granados Avenue and facade-mounted antennas in sector B would be approximately 90 feet from residences at 122 South Rios Avenue.

Facade-mounted antennas would also be more visible than the proposed penthouse design as they would likely require pop-out screen boxes to screen them from view. These screen boxes hide the antennas from view but create odd protrusions from the wall, which are generally less "stealth" than a mechanical penthouse that might otherwise appear as an ordinary architectural feature.<sup>11</sup> Moreover, pop-out boxes on the facade would potentially protrude more than 18 inches from the wall to allow sufficient space for the antennas, mounting equipment, RRUs, surge suppressors and the screening and framing material.<sup>12</sup> The comparison in **Figure 6** illustrates the difference in design.



**Figure 6:** Comparison between proposed mechanical penthouse design and "pop-out box" concealment for facade-mounted antennas. (Source: AT&T and Jonathan L. Kramer.)

In this case, strict compliance with the City's zone height limit would likely result in a design that is more visible and more intrusive than if the City permitted AT&T's proposed

<sup>10</sup> This estimate is based on the Topographic Survey included with AT&T's plans, which calls out the lowest finished grade as approximately 89 feet above MSL and the proposed antenna enclosure as approximately 153 feet above MSL (*i.e.*,  $153 - 89 = 64$ ).

<sup>11</sup> See Council Policy No. 21 § B.1 (requiring stealth designs such as false architectural elements).

<sup>12</sup> See *id.* § B.6.a (prohibiting protrusions that exceed 18 inches from the wall).



design. Overall height excluded, AT&T's current design would generally comply with the SBMC and Council Policy No. 21 because the equipment would be fully screened, architecturally integrated and would not produce any noise, emissions or other nuisance-type external effects.

### 3.3. City Multi-Site Alternative 1: 124 Lomas Santa Fe Drive

The potential alternative at 124 Lomas Santa Fe Drive may require that the City permit an additional site in order for AT&T to meet its technical service objectives. Whether the City prefers this alternative would depend on the extent to which the combination of a wireless facility located at 124 Lomas Santa Fe Drive and another facility located to the east would comply with the SBMC and Council Policy No. 21.

**Recommendation:** To the extent that the City would consider a multi-site solution with one site at 124 Lomas Santa Fe Drive, it should require AT&T to evaluate and submit design proposals at this location. In addition, the City should request that AT&T evaluate the following potential alternative sites for technical feasibility and potential availability:

- Light Industrial (LI) Parcels Along Stevens Avenue West (including without limitation):
  - Solana Beach Storage (545 Stevens Avenue)
  - Public Storage (477 Stevens Avenue)
  - Price Self Storage (533 Stevens Avenue West)
  - Smart Self Storage of Solana Beach (537 Stevens Avenue West)
- Commercial (C) Parcels Along San Rodolfo Drive and Solana Hills Drive (including without limitation)
  - Solana Beach Town Centre (663-689 Lomas Santa Fe Drive)
  - First Citizens Bank (706 Lomas Santa Fe Drive)
  - Citibank (740 Lomas Santa Fe Drive)
- The Solana Beach Presbyterian Church (120 Stevens Avenue)

A multi-site solution involving these locations would use more-preferred locations, but would undermine the City's general policy to reduce cumulative impacts from multiple sites through careful site selection. Moreover, we cannot reach any conclusion at this time as to whether the potential concealment design would be more or less preferable relative to single-site locations.

### 3.4. City Multi-Site Alternative 2: 100 Lomas Santa Fe Drive

As discussed in Section 2.4 of this memorandum, the potential alternative at 100 Lomas Santa Fe Drive may also require that the City permit an additional site in order for AT&T to meet its technical service objectives. Whether the City prefers this alternative would depend on the extent to which the combination of a wireless facility located at 100 Lomas



Santa Fe Drive and another facility located at 120 Stevens Avenue would comply with the SBMC and Council Policy No. 21.

**Recommendation:** To the extent that the City would consider a multi-site solution with one site at 100 Lomas Santa Fe Drive, it should require AT&T to evaluate and submit design proposals at this location. In addition, the City should request that AT&T evaluate the Solana Beach Presbyterian Church at 120 Stevens Avenue for technical feasibility and potential availability.

This potential alternative comes with the same tradeoffs as a multi-site solution with 124 Lomas Santa Fe. These locations would use more-preferred locations, but would undermine the City's general policy to reduce cumulative impacts from multiple sites through careful site selection. Although the Solana Beach Presbyterian Church seems promising from a concealment standpoint, we cannot reach any conclusion at this time as to whether the potential concealment design would be more or less preferable relative to single-site locations.

## 5. CONCLUSION

Based on the May 2017 Alternatives Analysis, there appears to be at least one more potentially viable single-site solution (210 Lomas Santa Fe Drive) and also various other multi-site solutions along Lomas Santa Fe Drive, Stevens Avenue and the commercial areas near Rodolfo Drive. Although the record does not currently contain sufficient information to meaningfully compare these various alternatives, it appears that fidelity to one preference compromises another. The City will need to weigh the tradeoffs between strict compliance with Council Policy No. 21 and potentially better concealment opportunities at lesser-preferred locations or taller structures.

The City will need additional analysis and information from AT&T to meaningfully compare the various tradeoffs among viable alternatives. Accordingly, the City should require AT&T to produce the additional information identified in this memorandum. AT&T's responses should be directly comparable to the materials provided in support of the Proposed Location. While it would not be appropriate at this time to require full zoning drawings for each alternative, any sketches or simulations should be sufficiently detailed to allow the City to comprehend the size, scale and visual impact of any alternatives.

RM



## WIRELESS PLANNING MEMORANDUM

**TO:** Corey Andrews  
**FROM:** Robert C. May  
**REVIEWER:** Jonathan L. Kramer  
**DATE:** October 18, 2017

**RE:** 17-17-15

**Applicant:** AT&T Mobility  
**Site Address:** 201 Lomas Santa Fe Drive, Solana Beach, California 92075  
**Site ID:** SD0925

The City of Solana Beach (the "**City**") requested a review for AT&T Mobility ("**AT&T**") to install a new building-mounted wireless site located at 201 Lomas Santa Fe Drive. This memorandum reviews the application and related materials for technical and regulatory issues specific to wireless infrastructure. Although many technical issues implicate legal issues, the analysis and recommendations contained in this memorandum do not constitute legal advice.

### 1. Project Background and Description

On May 4, 2017, this firm issued a memorandum to the City (the "**May Memo**") that recommended additional alternative sites analysis because it appeared that other, more-preferred alternatives would be technically feasible and potentially available. On or around July 30, 2017, AT&T responded with additional analysis (the "**May Alternatives Analysis**") that evaluated the currently proposed site location at 201 Lomas Santa Fe Drive, a scenario in which AT&T did not replace the decommissioned site ("**Alternative No. 1**") and three others located at 210 Lomas Santa Fe Drive ("**Alternative No. 2**"), 124 Lomas Santa Fe Drive ("**Alternative No. 3**") and 100 Lomas Santa Fe Drive ("**Alternative No. 4**").

On August 30, 2017, this firm issued a memorandum to the City (the "**August Memo**") that evaluated the May Alternatives Analysis and concluded that (1) Alternative No. 1 would not be technically feasible because it would result in a gap in AT&T's service; (2) Alternative No. 2 appeared technically feasible as a single-site alternative but recommended additional information about the site design due to potential concealment concerns; (3) Alternative Nos. 3 and 4 would most likely require a second site elsewhere

in the City to achieve reasonably comparable service coverage. The August Memo also included several suggested locations for a potential multi-site solution to be implemented if the City preferred Alternative Nos. 3 or 4 to the currently proposed site.

On September 21, 2017, AT&T responded to the August Memo (the "**September Alternatives Analysis**"). In the September Alternatives Analysis, AT&T (1) provided details to the potential design and concealment elements for Alternative No. 2; (2) ruled-out multi-site solutions proposed in the August Memo based on design concerns; and (3) ruled-out other alternative site locations based on their proximity to an existing AT&T site. While the September Alternatives Analysis responds to some of the design and viewshed concerns related to Alternative No. 2, it fails to provide adequate information to allow this firm or the City to fully evaluate AT&T's claim that a multi-site solution would not be feasible using the alternative sites proposed in the August Memo.

## **2. Alternative Sites Analysis**

### **2.1. Alternative No. 2 (210 Lomas Santa Fe Drive)**

Alternative No. 2 would be technically feasible as a stand-alone site or multi-site solution. However, the underlying building presents practical challenges for effective concealment.

AT&T evaluated a parapet wall extension at this location and points out that this configuration would result in a more dramatic change to the building envelope as compared to the single-enclosure in its current proposal. Specifically, AT&T would have to install a parapet wall extension approximately eight feet tall around the entire perimeter of the rooftop to conceal a potential site completely. That addition would significantly displace the viewshed to the west of the property because the parapet extension would block the existing view of the beach shoreline from the east. The September Alternatives Analysis also included photo simulations to illustrate the visual impact that would result from a split-sector design, which is reproduced in Figure 1.



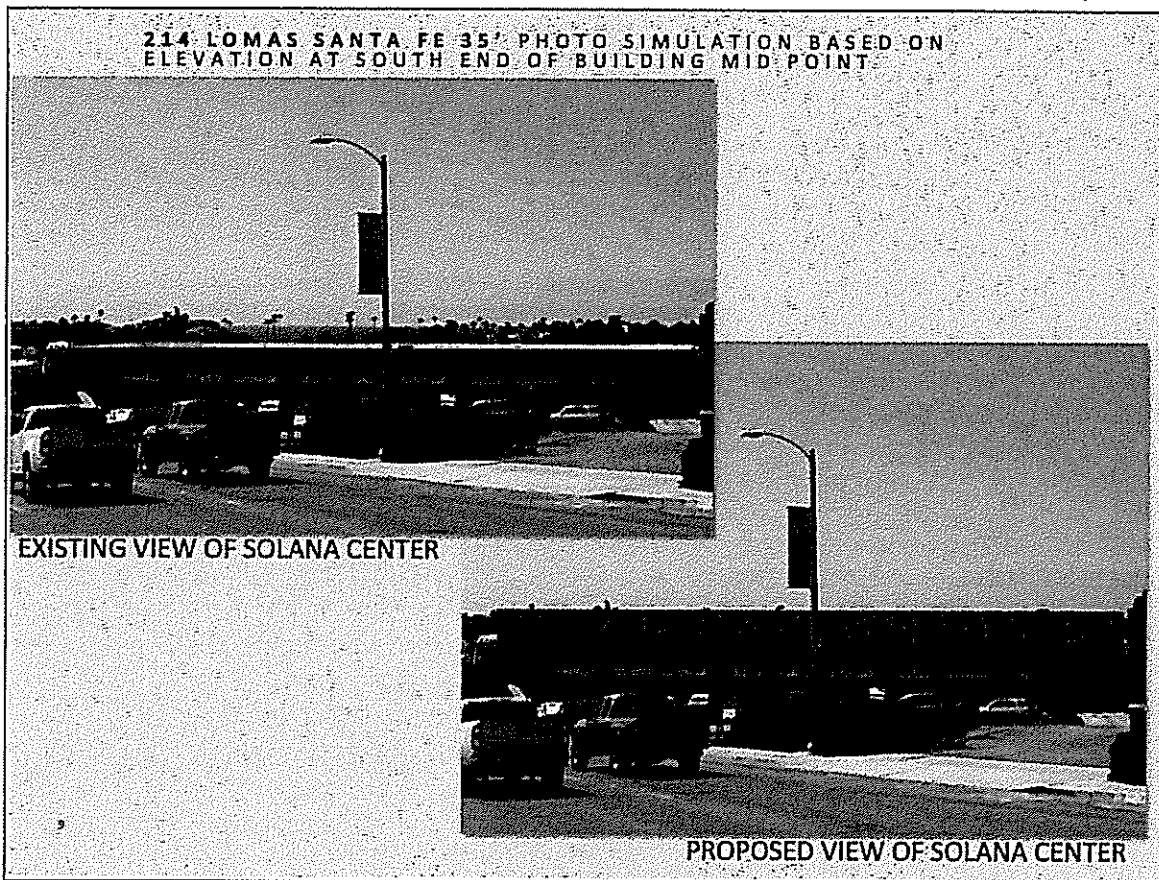


Figure 1: Photo simulation to show possible parapet extension to screen antennas. (Source: AT&T.)

We tend to agree with AT&T on this point. Although the parapet wall depicted in the simulation could be designed and finished to blend with the underlying building, the extension at this location would displace more viewshed than the design proposed at 201 Lomas Santa Fe. Given the City's preference for building-mounted facilities over freestanding towers, additional efforts to investigate other designs may not be fruitful. Moreover, a stand-alone site at this location would create a similar viewshed displacement issue because it would place a tall visual obstruction on the property where no obstruction currently exists. Accordingly, the proposed location would appear to have less of a negative visual impact than a technically feasible design at this location.

## 2.2. Alternative No. 3 (124 Lomas Santa Fe Drive)

AT&T did not consider Alternative No. 3 because it would require a second site to complete its coverage objectives, and because the building at 210 Lomas Santa Fe would block the signal propagation to the east. AT&T relies on the coverage maps submitted to the City as evidence of this alternative's inability to achieve the desired coverage objectives. This is not an adequate response to rule-out this location as a potential candidate for a multi-site solution because the coverage maps show AT&T could achieve



the desired coverage objective to the west at this location. Although this location could present viewshed issues similar to those discussed for Alternative No. 2, AT&T did not provide enough information to evaluate what type of design, and potential visual impact, would occur here.

As discussed in Sections 2.4 and 2.5 to this memorandum, there appear to be several potential locations for a second site that could achieve AT&T's coverage objectives when combined with a site at this location. The September Alternative Analysis includes a conclusory statement that this location has "low building height and limited architectural features" for a feasible design. However, AT&T did not provide a factual analysis that addresses the possibility of a feasible multi-site design that involves this location. Accordingly, the City should find that AT&T has not provided a technical reason why a site at Alternative No. 3 would be infeasible even when combined with a second site to the east.

### **2.3. Alternative No. 4 (100 Lomas Santa Fe Drive)**

AT&T did not consider Alternative No. 4 because it would require a second site to complete its coverage objectives. This is not an adequate response to rule-out this location as a potential candidate for a multi-site solution because AT&T admittedly did not consider how it could achieve the coverage objectives coupling this location with a second-site location. Like Alternative No. 3, AT&T's coverage map for this location appears to show a site would achieve the coverage objective to the west but AT&T eliminated this option because the location has "low building height and limited architectural features." Again, AT&T did not provide factual evidence to show a site at this location would create viewshed displacement as AT&T showed for Alternative No. 2.

As discussed in Sections 2.4 and 2.5 to this memorandum, there appear to be several potential locations for a second site that could achieve AT&T's coverage objective when combined with a site at this location. Accordingly, the City should find that AT&T has not provided a technical reason why a site at Alternative No. 4 would be infeasible even when combined with a second site to the east.

### **2.4. Alternative No. 5 (Solana Beach Presbyterian Church)**

The Solana Beach Presbyterian Church appears to be technically feasible as a supplement to either Alternative Nos. 3 or 4. AT&T "[a] simulation of the best location to cover the apex of Lomas Santa Fe to the west is provided in the coverage map package." The coverage map mentioned in the quoted text above appears in Figure 2.



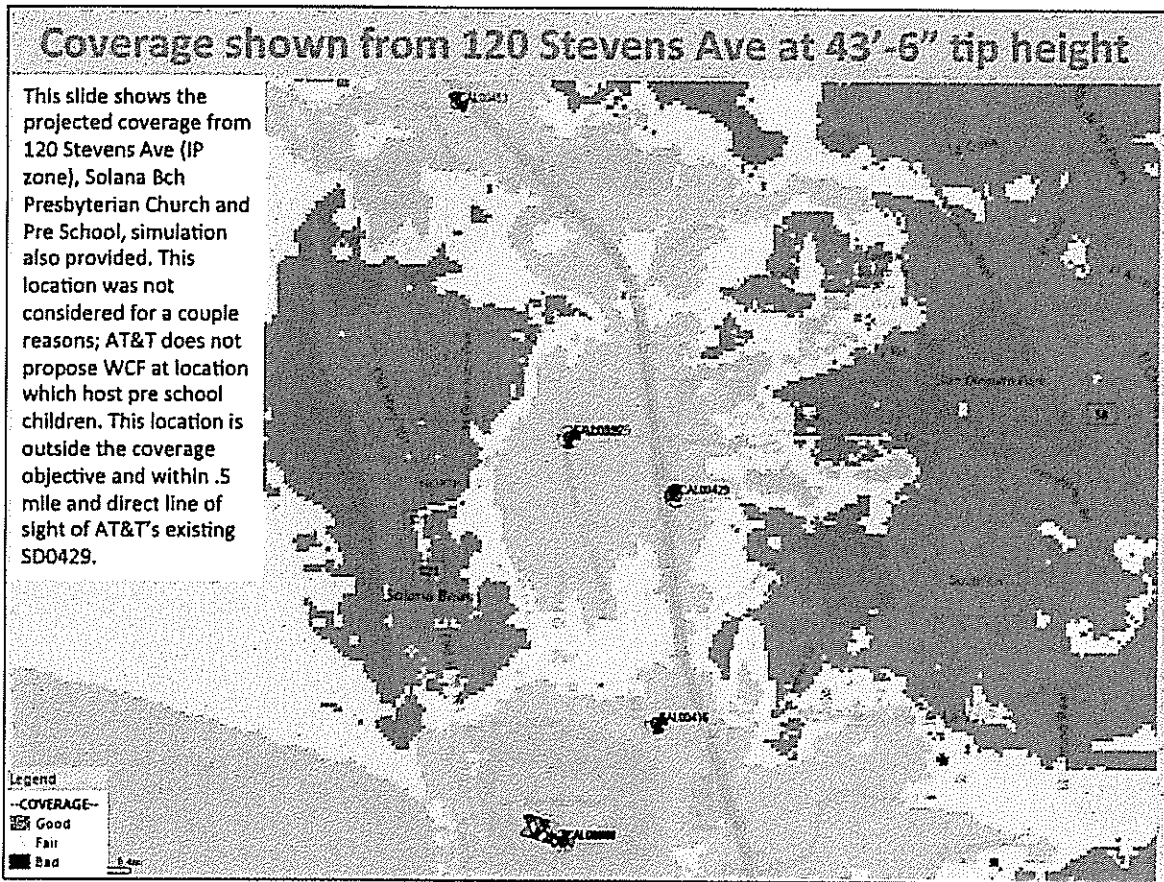


Figure 2: Coverage map to show predicted service from Solana Beach Presbyterian Church. (Source: AT&T.)

Upon review, a proposed site at the Solana Beach Presbyterian Church would not be technically feasible as a stand-alone site but may be a potentially feasible supplement to Alternative Nos. 3 or 4. A site at this location would not be technically feasible as a stand-alone site because it would not be able to achieve the coverage objective to the west. Although the site on its own cannot reach areas to the west, which are shaded due to the rise in elevation, it could be a technically feasible multi-site solution with Alternatives Nos. 3 or 4. Predicted service levels for a site at this location drop off fairly sharply west of South Nardo Avenue. However, a side-by-side comparison shows that the combined coverage would reach all areas in AT&T's search ring. Accordingly, the Solana Beach Presbyterian Church appears to be a technically feasible alternative under a multi-site solution.





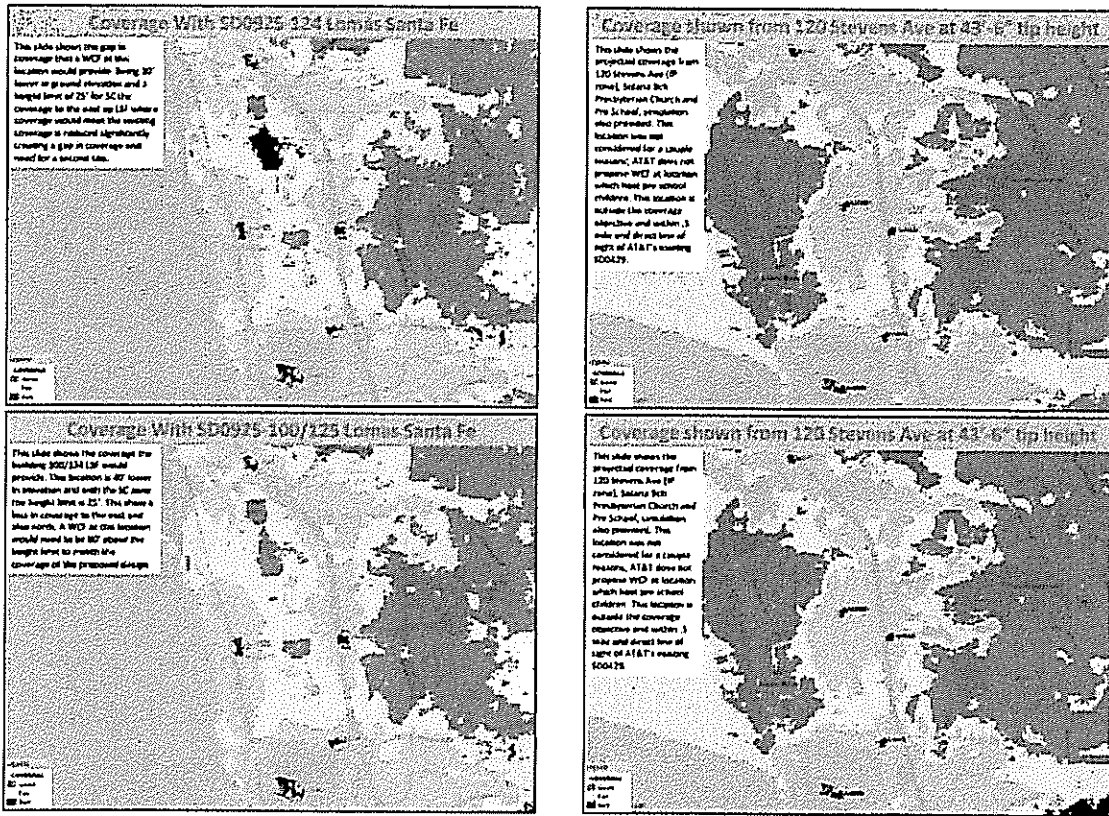


Figure 3: Side-by-side coverage maps to show predicted service with Alternative Nos. 3 and 4 and Solana Beach Presbyterian Church. (Source: AT&T.)

Although the Solana Beach Presbyterian Church may be technically feasible, it also presents some possible challenges. As AT&T points out, it initially ignored this location due to the general opposition it receives to proposed installations on churches with pre-school or daycare facilities.

There is no indication in the record as to whether the church would grant AT&T a lease. To fully vet this potential alternative, the City should require AT&T to investigate whether the church would be a willing landlord. If so, the City should consider this a potential location in a multi-site solution. If not, the City should consider this location ruled-out.

### 2.5. Alternative No. 6 (Multi-Site Deployment)

As mentioned above, AT&T states that it did not consider any multi-site deployment due to "low building height and limited architectural features at [Alternative Nos. 3 and 4] . . . ." However, the low overall height at these locations was the precise reason why we recommended that AT&T evaluate whether a second or third site in the more preferred zones along Stevens Avenue or Lomas Santa Fe might compensate for any deficit in coverage. Moreover, while the City may determine that limited architectural features at



Alternatives No. 3 and 4 render them less desirable than other alternatives, the applicant cannot base its own analysis on subjective aesthetics.<sup>1</sup>

AT&T also analyzed all seven locations along Stevens Avenue and Lomas Santa Fe and determined all seven would be technically infeasible as potential stand-alone sites. According to the September Alternatives Analysis, the potential sites in the light industrial zone along Stevens Avenue and the commercial zone along Lomas Santa Fe Drive would be outside the "coverage objective" and "too close" to another AT&T site located at 200 Marine View Avenue (Site No. SD0429) "less than 2000 feet" away.

Sites situated outside the "coverage objective" would not necessarily rule them out as potential supplemental sites to Alternative Nos. 3 or 4; however, their proximity to Site No. SD0429 might cause interference at the cell edge. To determine whether any sites within these more preferred zones would still be technically feasible as a supplemental site, the distances between Site No. SD0429 and each alternative have been measured. In addition, two other potential supplemental sites have been identified and included. The results appear in Table 1.

Alternative Site	Zone	Dist. to SD0429
<b>Alternatives from August Memo</b>		
545 Stevens Avenue	LI	~2,220 feet
537 Stevens Avenue	LI	~2,095 feet
533 Stevens Avenue	LI	~1,860 feet
477 Stevens Avenue	LI	~1,240 feet
740 Lomas Santa Fe	C	~1,670 feet
706 Lomas Santa Fe	C	~1,720 feet
663 Lomas Santa Fe	C	~1,800 feet
<b>Additional Alternatives Identified</b>		
685 San Rodolfo Dr.	C	~2,150 feet
380 Stevens Avenue	c	~2,015 feet

Table 1: Approximate distance from proposed alternative sites to AT&T existing site SD0429.

Based on the 2,000-foot separation requirement in AT&T's September Alternatives Analysis, the following locations appear to be technically feasible as supplemental sites to Alternatives Nos. 3 or 4: (1) 545 Stevens Avenue; (2) 537 Stevens Avenue; (3) 685 San Rodolfo Drive; and (4) 380 Stevens Avenue. Each is more than 2,000 feet from the existing Site No. SD0429. While none may be technically feasible as a stand-alone site, each appears technically feasible as a supplemental site in a multi-site solution. As such, the City should require AT&T to investigate each location listed Table 1 that is over 2,000 feet from Site No. SD0429 to determine if the location would be technically feasible as a multi-site solution and if the respective landowners for the technically feasible solutions would be willing landlords.

<sup>1</sup> See, e.g., *American Tower Corp. v. City of San Diego*, 763 F.3d 1035, 1057 (9th Cir. 2014).



### 3. Conclusion and Recommendations

The following summarizes the conclusions to be drawn from the September Alternatives Analysis, and recommended next steps the City may wish to take:

1. **Alternative No. 2 (210 Lomas Santa Fe Drive):** Alternative No. 2 remains potentially viable. This location would be technically feasible either as a stand-alone facility or in a multi-site solution. However, the record contains no information about whether the owner would lease space to AT&T, and the building design presents less desirable concealment options than are available at 201 Lomas Santa Fe Drive. The City should require AT&T to investigate other concealment options to decrease the potential viewshed displacement and the landowner's willingness to lease the necessary space for the site.
2. **Alternative No. 3 (124 Lomas Santa Fe Drive):** Alternative No. 3 remains potentially feasible. AT&T declined to evaluate this location in a multi-site solution and therefore has not identified a technical feasibility or potential availability reason why this alternative should be ruled-out. Additional evaluation should be performed by AT&T as requested by the City. Specifically, the City should require additional information about whether a multi-site solution is feasible and if the landowner would be interested in a lease.
3. **Alternative No. 4 (100 Lomas Santa Fe Drive):** Alternative No. 4 remains potentially feasible. AT&T declined to evaluate this location in a multi-site solution and therefore has not identified a technical feasibility or potential availability reason why this alternative should be ruled-out. Additional evaluation should be performed by AT&T as requested by the City. Specifically, the City should require additional information about whether a multi-site solution is feasible and if the landowner would be interested in a lease.
4. **Alternative No. 5 (Solana Beach Presbyterian Church):** Alternative No. 5 would not be technically feasible as a stand-alone site, but appears to be technically feasible in a multi-site solution with opportunities for concealment. However, the record contains no information about whether the owner would lease space to AT&T. The City should require additional information about whether the church would be interested in a lease.
5. **Alternative No. 6 (Multi-Site Solutions):** A multi-site solution remains potentially feasible. Although AT&T provided a valid technical reason to rule-out five potential locations identified in the August Memo, four potential sites appear technically feasible. The remaining sites are: 380 Stevens Avenue; 545 Stevens Avenue; 537 Stevens Avenue; and 685 San Rodolfo Drive. AT&T should perform additional evaluation as requested by the City. Specifically, the City should require additional information for each location about whether a multi-site solution is feasible and if the landowner would be interested in a lease.



For the alternatives discussed above, AT&T should provide any sketches, coverage maps or simulations with enough detail to allow the City to evaluate the technical feasibility, size, scale and visual impact of each location.

RM





# STAFF REPORT CITY OF SOLANA BEACH

**TO:** Honorable Mayor and City Councilmembers  
**FROM:** Gregory Wade, City Manager  
**MEETING DATE:** February 14, 2018  
**ORIGINATING DEPT:** Community Development Department  
**SUBJECT:** **Public Hearing: CUP/DRP/SDP for a New Wireless Communications Facility at 201 Lomas Santa Fe (Case # 17-17-15 Applicant: AT&T Mobility) Resolution 2017-166**

---

## **BACKGROUND:**

The Applicant, AT&T Mobility (hereinafter referred to as "Applicant"), is requesting the approval of a Conditional Use Permit (CUP), Development Review Permit (DRP) and Structure Development Permit (SDP) to construct a new Wireless Communication Facility (WCF) on top of an existing commercial office building at 201 Lomas Santa Fe. The Applicant is proposing to increase the height of an existing elevator tower in order to construct a new antenna enclosure that would conceal 12 panel antennas, 32 Remote Radio Units (RRU's), six surge suppressors, and two GPS antennas behind fiber reinforced plastic screening colored and textured to match the existing building. A new ground level equipment enclosure would be installed that would contain four stack-mounted radio equipment cabinets, one power cabinet, one battery cabinet and telephone and electric utility panels on a concrete slab foundation. The enclosure would be located in the location that is currently a landscape planter adjacent to the building entrance. The antenna enclosure would increase the width and depth of the top 12 feet of the existing tower by three feet and the height by four feet. The highest point of the proposed antennas will be 41.5 feet above the existing grade and 153.2 feet above the existing grade. Solana Beach Municipal Code (SBMC) section 17.60.120(G)(1) indicates that all WCF's are subject to a CUP and must comply with City Council Policy 21. A DRP is required for "any new commercial development or construction (including any structural addition to existing development) located within any commercial zone which results in an increase of more than 500 feet of gross floor area or to the overall building envelope." The proposed addition would exceed 16 feet in height from the existing grade and, therefore, requires a Structure Development Permit (SDP).

This item is before the City Council to approve, conditionally approve or deny the Applicant's request for a CUP, DRP, and SDP for a new WCF at 201 Lomas Santa Fe, Solana Beach, as contained in Resolution 2017-167 (Attachment 1).

CITY COUNCIL ACTION:

---

---

---

## **DISCUSSION:**

This project was originally heard at the December 13, 2017 City Council meeting. The original Staff Report has been provided in Attachment 2. At that meeting, the proposed project and several alternative sites were discussed. The Applicant indicated that an existing site on Lomas Santa Fe is being decommissioned and because of that, there would be a significant gap in coverage. By constructing the proposed site at 201 Lomas Santa Fe, that significant gap would be addressed. The federal Telecommunications Act of 1996 indicates that local governments cannot prohibit or effectively prohibit personal wireless communication services. If an Applicant demonstrates that there is a "significant gap" in their service coverage and the proposed site constitutes the "least intrusive means" to mitigate that significant gap, the Ninth Circuit holds that a single permit denial violates the Telecom Act.

After receiving public testimony and evidence regarding the project at the Council meeting, the Council indicated that they were not able to make the finding that the proposed project design constitutes the "least intrusive means" in addressing the gap in coverage. The Council requested that the Applicant provide additional analysis for the project site based on aesthetic concerns. Specifically, the Council requested information regarding the feasibility of separating the antenna sectors and install several radio frequency (RF) transparent screening boxes on different sides of the structure at lower heights. The Council also requested to see a sample of what the proposed RF transparent screening material would look like to verify that it would in fact match the existing exterior of the structure in color and texture. The Applicant agreed to provide the requested information. The council voted 5/0 to continue the project to a date certain of January 10, 2018.

At the January 10, 2018 City Council meeting the Applicant presented two project alternatives. The Council expressed concerns that the alternatives presented did not constitute the least intrusive means to address the significant gap. The Council asked the Applicant if they would agree to an extension to the tolling agreement to allow for additional time to review additional onsite project alternatives. The Applicant agreed to a tolling agreement extension. The Council voted 5/0 to continue the project to a date certain on February 14, 2018.

The Applicant held an onsite meeting with the City's Telecom Consultant, the City Manager, and Staff to discuss potential project alternatives on January 25, 2018. At that meeting a new project alternative, alternative 3, was discussed as well as modifications to the existing landscaping along the eastern elevation and the replacement of the tree south of the existing elevator tower.

Project alternative 3 incorporates the following changes from the original design:

- The Applicant is proposing move the eastern sector of the proposed antennas to the northeast corner of the building and install 2.3' antennas behind the existing parapet which would be replaced by Radio Frequency Transparent material that is colored and textured to match the existing parapet wall on the building. The

existing parapet will look the same as it currently exists, however, there is a 5 inch gap approximately three feet below the top rail along the roofline that would be enclosed.

- The three remaining antenna sectors would stay on top of the existing elevator tower, however, they the tower would only increase by six inches in height above the existing roof. The additional six inches is needed to conceal to coax sweep from the RRU's which will all be located back to back on the roof just east of the elevator shaft behind a concealment wall at the same height as the existing parapet. Again, an existing 5 inch gap below the parapet will be filled.
- The Applicant and landlord have agreed to remove the existing bamboo that encroaches into the public right-of-way along the eastern property line and replace it with a chain link fence. The Applicant would also plant vines that would grow along the fence. As a condition of approval, the fence and vines would have a ERMA agreement with the City Engineer.
- The Applicant has indicated that they will remove the existing tree that is just south of the existing elevator tower. The City's third party landscape architect has reviewed the existing location of the landscape enclosure and the proposed location of the equipment enclosure to ensure that a large replacement tree would be able to establish and survive in the new smaller landscaped area. The recommendation from Pamela is XXXX.

The Applicant has provided the attached revised project plans and photo simulations to reflect the revisions described above. (Attachment 3)

A draft Resolutions have been provided based upon the alternative project design as presented in this report. It includes the applicable SBMC sections in italicized text. The Council may direct Staff to modify the Resolution to reflect the findings and conditions it deems appropriate as a result of the public hearing process.

**CEQA COMPLIANCE STATEMENT:**

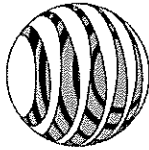
The project is exempt from the California Environmental Quality Act (CEQA) pursuant to Section 15301 of the State CEQA Guidelines.

**FISCAL IMPACT:** N/A

**WORK PLAN:** N/A

**OPTIONS:**

- Approve Staff recommendation adopting the attached Resolution 2017-167.
- Approve Staff recommendation subject to additional specific conditions necessary for the City Council to make all required findings for the approval of a DRP.

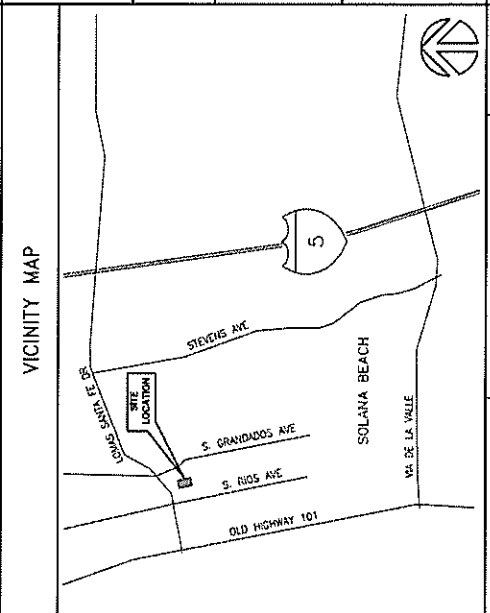


# SITE NUMBER: SD0925

# SITE NAME: LOMAS SANTA FE

APPROVAL	DATE	SIGNATURE
P.M. :		
C.M. :		
S.A.C. :		
R.F. :		
ZONING :		

<b>DRAWING INDEX (ZONING)</b> T01 TITLE SHEET A01 SITE PLAN A02 ANTENNA LAYOUT PLAN A03 EQUIPMENT LAYOUT PLAN A04 ELEVATIONS A05 ELEVATION A06 EQUIPMENT ON WALL ENCLOSURE ELEMENTS A07 ANTENNA AND IRU CONFIGURATION AND SPECIFICATIONS A08 STORM DRAIN AND STEEL GRATE UD PLAN C01 STAKE POLE PLOT PLAN L01 BRICATION PLAN L02 IRRIGATION DETAILS AND WATER CALCS L03 PLANTING PLAN S01 TOPOGRAPHIC SURVEY S02 TOPOGRAPHIC SURVEY 15 SHEETS TOTAL	<b>REV.</b> 8 7 6 5 4 3 2 1	<b>DIRECTIONS</b> FROM AT&T SAN DIEGO OFFICE 1. TURN RIGHT ON I-15 SOUTH 2. TURN LEFT ONTO CAMINO SANCTA FE 3. TURN RIGHT ONTO LOMAS SANTA FE 4. TURN LEFT ONTO WEST SIDE OF LOMAS SANTA FE 5. AT EXIT 33A, TAKE RAMP RIGHT AND FOLLOW SIGNS FOR LOCAL BYPASS 6. TAKE RAMP LEFT AND FOLLOW SIGNS FOR I-5 NORTH 7. AT EXIT 33, TAKE RAMP RIGHT AND FOLLOW SIGNS FOR LOMAS SANTA FE DR 8. AT END OF I-5, TAKE RAMP RIGHT AND FOLLOW SIGNS FOR LOMAS SANTA FE DR 9. ARRIVE AT LOMAS SANTA FE DR	<b>DEVELOPMENT SUMMARY</b> <b>PROJECT SCOPE OF WORK:</b> THIS PROJECT DETAILS THE INSTALLATION OF: 1. (1) 10' HIGH WALL ENCLOSURE WITH STEEL GRATING UD 2. (1) 10' HIGH SCREEN WALL 3. (1) SCREEN WALL TO CONDUIT, PUS & DC-6 4. (12) PANEL ANTENNAS, (2) RRU's & (6) DC-6 SURGE SUPPRESSORS 5. (2) GPS ANTENNAS NOTE: THE TOTAL LANDSCAPE SQ. FT. SHOULD BE BELOW 500 SQ. FT.	<b>PROPERTY INFORMATION:</b> OWNER: SCSA TRINITY LP C/O CARLOS MORALES ADDRESS: 1200 BEASLEY BLVD, #300 MIAMI, FL 33122 ASSESSOR PARCEL NUMBER: 296-015-01-00 LEASE AREA: 200 SQ. FT. <b>CONTACT:</b> NAME: CARLOS MORALES ADDRESS: 1200 BEASLEY BLVD, #300 MIAMI, FL 33122 PHONE: (305) 760-0100 EXT. 4 FAX: (305) 760-0100 E-MAIL: CMORALES@SCSALP.COM
	<b>CODE COMPLIANCE</b> 1. 2016 CALIFORNIA UNIVERSAL CODE (CUC) 2. 2016 CALIFORNIA BUILDING CODE (CBC), VOLUMES 1, AND 2 3. 2016 CALIFORNIA ELECTRICAL CODE (CEC) 4. 2016 CALIFORNIA MECHANICAL CODE (CMC) 5. 2016 CALIFORNIA PLUMBING CODE (CPC) 6. 2016 CALIFORNIA FIRE CODE (CFC) 7. 2016 CALIFORNIA GREEN CODE (CGC) 8. 2016 CALIFORNIA REFERENCED STANDARDS CODE	<b>PROJECT TEAM:</b> PROJECT MANAGER: DEBRA J. BROWN DESIGNER: DEBRA J. BROWN CHECKER: DEBRA J. BROWN DATE: 08/14/2018	<b>EXISTING INFOS ON SAME PROPERTY:</b> NONE	<b>PROPERTY INFORMATION:</b> OWNER: SCSA TRINITY LP C/O CARLOS MORALES ADDRESS: 1200 BEASLEY BLVD, #300 MIAMI, FL 33122 ASSESSOR PARCEL NUMBER: 296-015-01-00 LEASE AREA: 200 SQ. FT. <b>CONTACT:</b> NAME: CARLOS MORALES ADDRESS: 1200 BEASLEY BLVD, #300 MIAMI, FL 33122 PHONE: (305) 760-0100 EXT. 4 FAX: (305) 760-0100 E-MAIL: CMORALES@SCSALP.COM



SD0925

LOMAS SANTA FE

291 LOMAS SANTA FE DRIVE

SOLANA BEACH, CA 92509

DCI PACIFIC

AIRC WORKS

4000 WILSON AVENUE, SUITE 100

IRVINE, CA 92618

TITLE SHEET

T01

DATE: 08/14/2018

SCALE: AS SHOWN

REVISIONS:

NO.	DATE	BY	CHK'D BY	DESCRIPTION
1				ISSUED FOR PERMIT



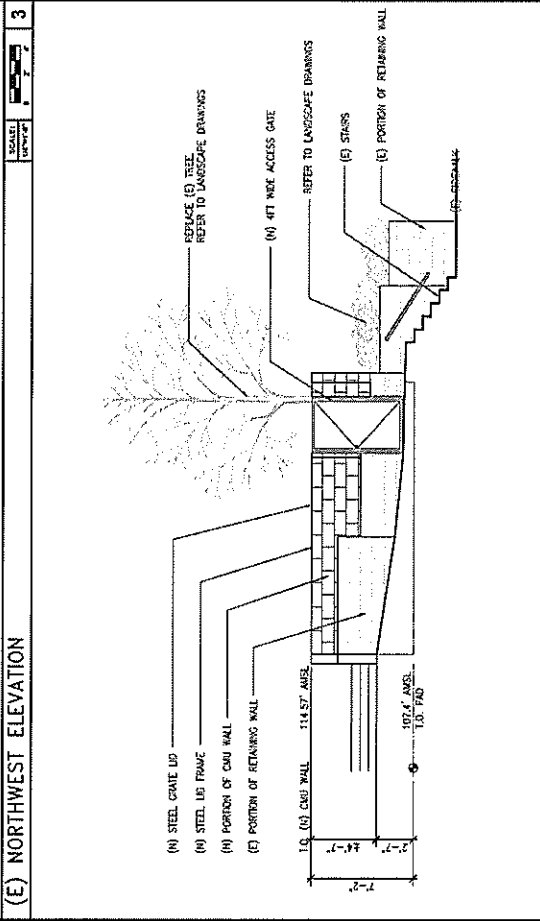
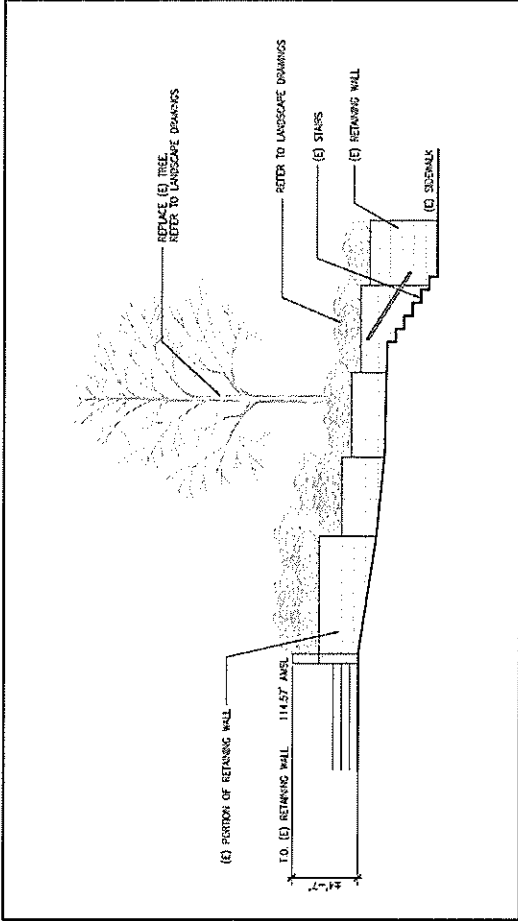
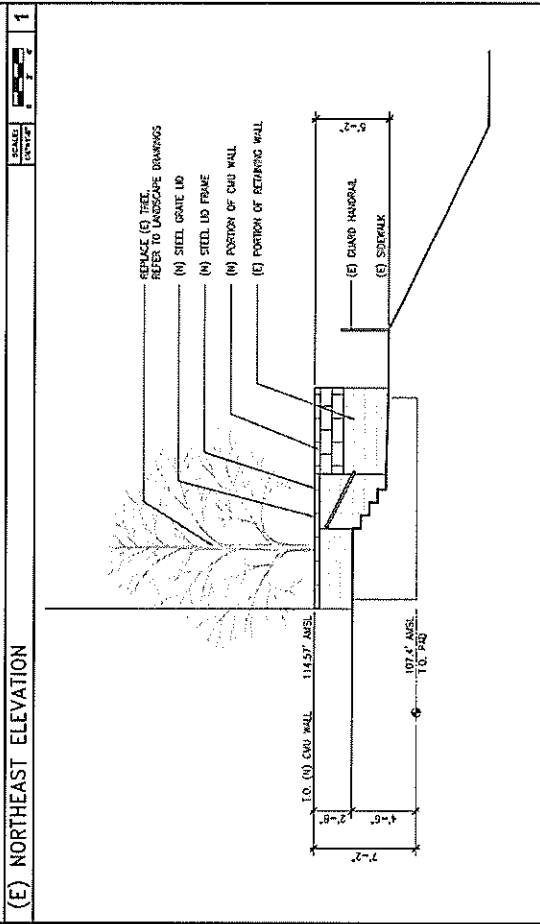
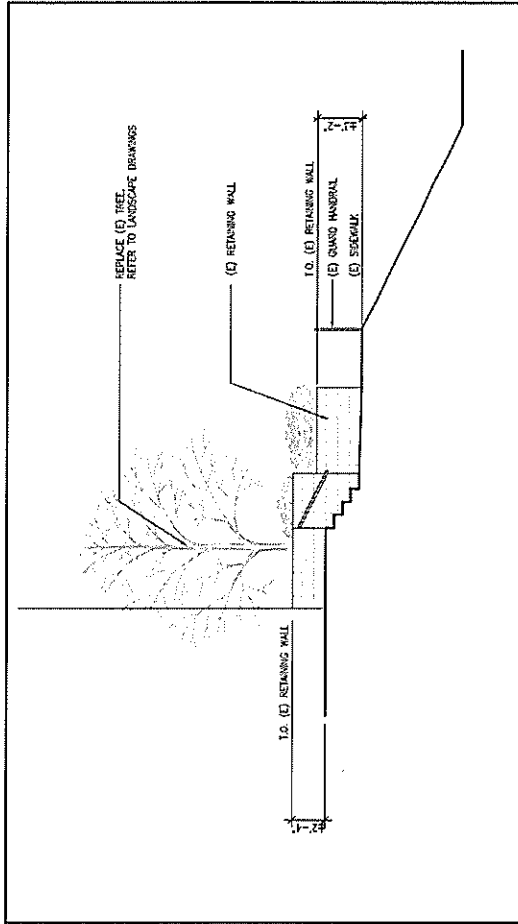












**(E) NORTHWEST ELEVATION**

SCALE: 1/8" = 1'-0"

1

**(E) NORTHEAST ELEVATION**

SCALE: 1/8" = 1'-0"

2

**(E) NORTHWEST ELEVATION**

SD0925  
 LOMAS SANTA FE  
 201 LOMAS SANTA FE DRIVE  
 SOLANA BEACH, CA 92075

at&t  
 7815 TRAVIS STREET, SUITE 1000, SAN DIEGO, CA 92123

DePratti Inc.

DCI PACIFIC  
 AIEIC WORKS  
 4000 WILSON AVENUE, SUITE 100  
 MANASSAS, VA 20108

**(N) NORTHWEST ELEVATION**

SD0925  
 LOMAS SANTA FE  
 201 LOMAS SANTA FE DRIVE  
 SOLANA BEACH, CA 92075

at&t  
 7815 TRAVIS STREET, SUITE 1000, SAN DIEGO, CA 92123

DePratti Inc.

DCI PACIFIC  
 AIEIC WORKS  
 4000 WILSON AVENUE, SUITE 100  
 MANASSAS, VA 20108

**(N) NORTHEAST ELEVATION**

SCALE: 1/8" = 1'-0"

4

3

NO.	DATE	BY	CHK	APP
1	12/22/17	JK	JK	JK
2	12/22/17	JK	JK	JK
3	12/22/17	JK	JK	JK
4	12/22/17	JK	JK	JK
5	12/22/17	JK	JK	JK
6	12/22/17	JK	JK	JK

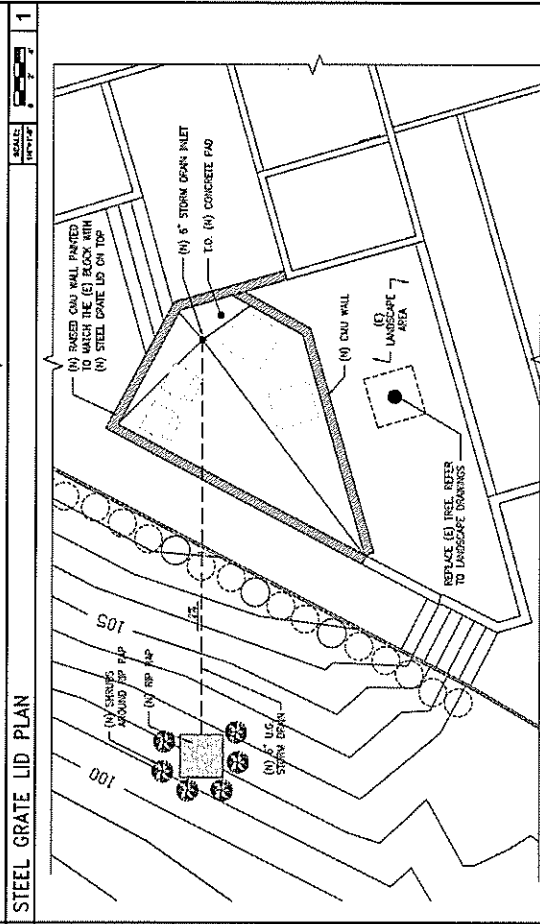
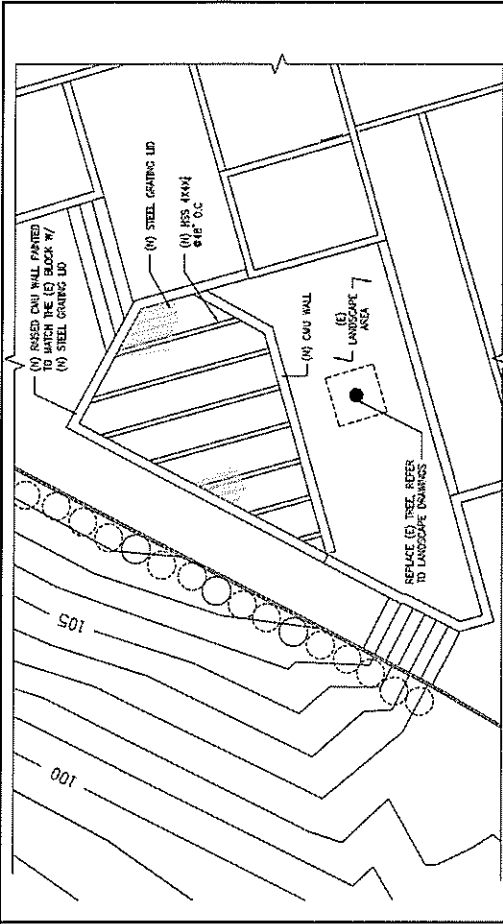
SCALE: AS SHOWN

DATE: 12/22/17

PROJECT: EQUIPMENT CHU WALL ENCLOSURE ELEVATIONS

**A06**





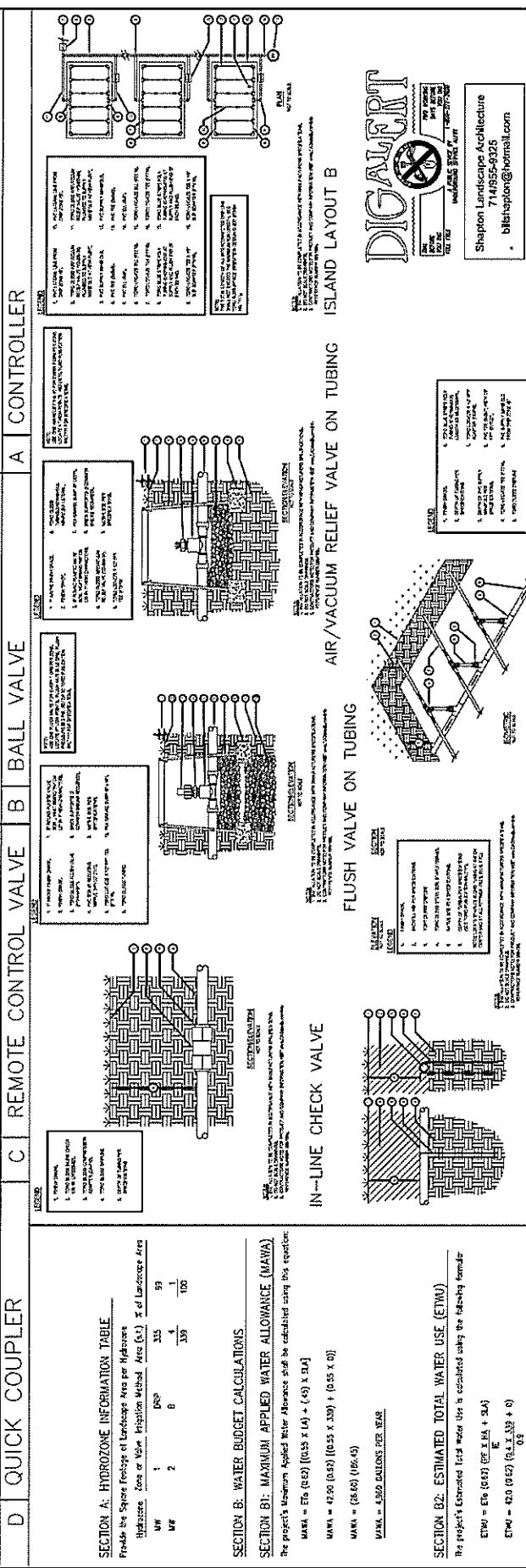
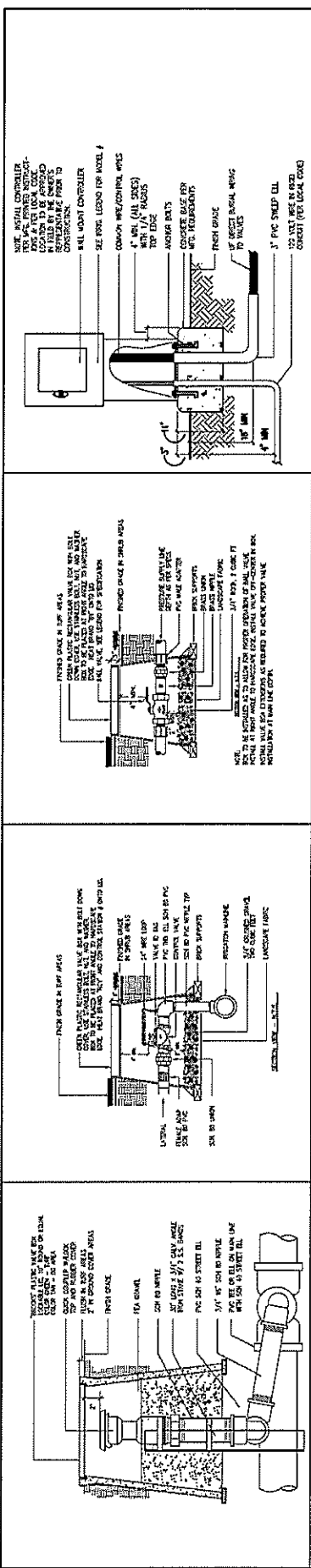
STEEL GRATE LID PLAN

STORM DRAIN PLAN

 7317 FRANK STREET, EAST RICHMOND, CA 94804 SAN FRANCISCO, CA 94114-0222	 DePratti Inc.	SD0925 LOMAS SANTA FE 201 LOMAS SANTA FE DRIVE SOLANA BEACH, CA 92075	<b>DCI PACIFIC</b> CIVIL WORKS AN AFFILIATE OF THE CIVIL ENGINEERING PROFESSIONAL CORPORATION	SHEET NUMBER <b>A08</b>	
				STORM DRAIN AND STEEL GRATE LID LAYOUT PLAN	
SCALE: AS SHOWN SHEET NO. 1 OF 2		DATE: 07/27/11 REVISIONS:		SCALE: 1/4" = 1'-0" SHEET NO. 2 OF 2	
1 07/27/11 PER REVISED 2D NETWORK DESIGN 2 07/27/11 PER REVISED 2D NETWORK DESIGN 3 07/27/11 REVISION FOR CITY COMMENTS & PER REVIEW 4 07/27/11 REVISION FOR CITY COMMENTS & PER REVIEW 5 07/27/11 REVISION FOR CITY COMMENTS & PER REVIEW		1 07/27/11 PER REVISED 2D NETWORK DESIGN 2 07/27/11 PER REVISED 2D NETWORK DESIGN 3 07/27/11 REVISION FOR CITY COMMENTS & PER REVIEW 4 07/27/11 REVISION FOR CITY COMMENTS & PER REVIEW 5 07/27/11 REVISION FOR CITY COMMENTS & PER REVIEW		1 07/27/11 PER REVISED 2D NETWORK DESIGN 2 07/27/11 PER REVISED 2D NETWORK DESIGN 3 07/27/11 REVISION FOR CITY COMMENTS & PER REVIEW 4 07/27/11 REVISION FOR CITY COMMENTS & PER REVIEW 5 07/27/11 REVISION FOR CITY COMMENTS & PER REVIEW	







SEE SHEET L02 FOR IRRIGATION DETAILS AND WATER CALCS  
SEE SHEET L03 FOR PLANTING PLAN

**SECTION A: HYDROZONE INFORMATION TABLE**  
 Provide the Square Footage of Landscape Area per Hydrozone

Hydrozone	Zone or Valve Irrigation Method	Area (Sq. Ft.)	% of Landscape Area
1	DRIP	315	93
2	0	4	1
		319	100

**SECTION B: WATER BUDGET CALCULATIONS**  
**SECTION B1: MAXIMUM APPLIED WATER ALLOWANCE (MAWA)**  
 The project's Maximum Applied Water Allowance shall be calculated using the equation:  
 $MAWA = ETh (0.62) [(0.55 \times LA) + (49) \times DA]$   
 $MAWA = 42.62 (0.62) [(0.55 \times 319) + (0.55 \times 0)]$   
 $MAWA = (26.65) (106.45)$   
 $MAWA = 2,839 \text{ GALLONS PER YEAR}$

**SECTION B2: ESTIMATED TOTAL WATER USE (ETWU)**  
 The project's Estimated Total Water Use is calculated using the following formulae:  
 $ETWU = ETh (0.62) [(0.5 \times LA) + (54)]$   
 $ETWU = 42.0 (0.62) [(0.5 \times 319) + 0]$   
 $ETWU = (26.69) (166.65)$   
 $ETWU = 4,439 \text{ GALLONS PER YEAR FOR HYDROZONES 1-2}$

**WATER CALCULATIONS**

**DRIP LINE DETAILS**

**STAPLE - BELOW GRADE**

**MANIFOLD CENTER FEED**

**FLUSH VALVE ON TUBING**

**AIR/VACUUM RELIEF VALVE ON TUBING**

**ISLAND LAYOUT B**

**QUICK COUPLER**

**REMOTE CONTROL VALVE**

**BALL VALVE**

**CONTROLLER**

**at&t**  
 7301 FRANK STREET, SUITE 300, ROCKAWAY, CALIFORNIA 92675

**DePratti inc.**

**SD0925**  
**LOMAS SANTA FE**  
 201 LOMAS SANTA FE DRIVE  
 SOLANA BEACH, CA 92075

**DCI PACIFIC**  
**AIEIC WORKS**  
 1000 JEFFERSON AVENUE, SUITE 100  
 BOSTON, MASSACHUSETTS 02115

**Shapton Landscape Architecture**  
 714855-9325  
 blshapton@hotmail.com

**DIGALERT**

**IRRIGATION DETAILS AND WATER CALCS**

**L02**





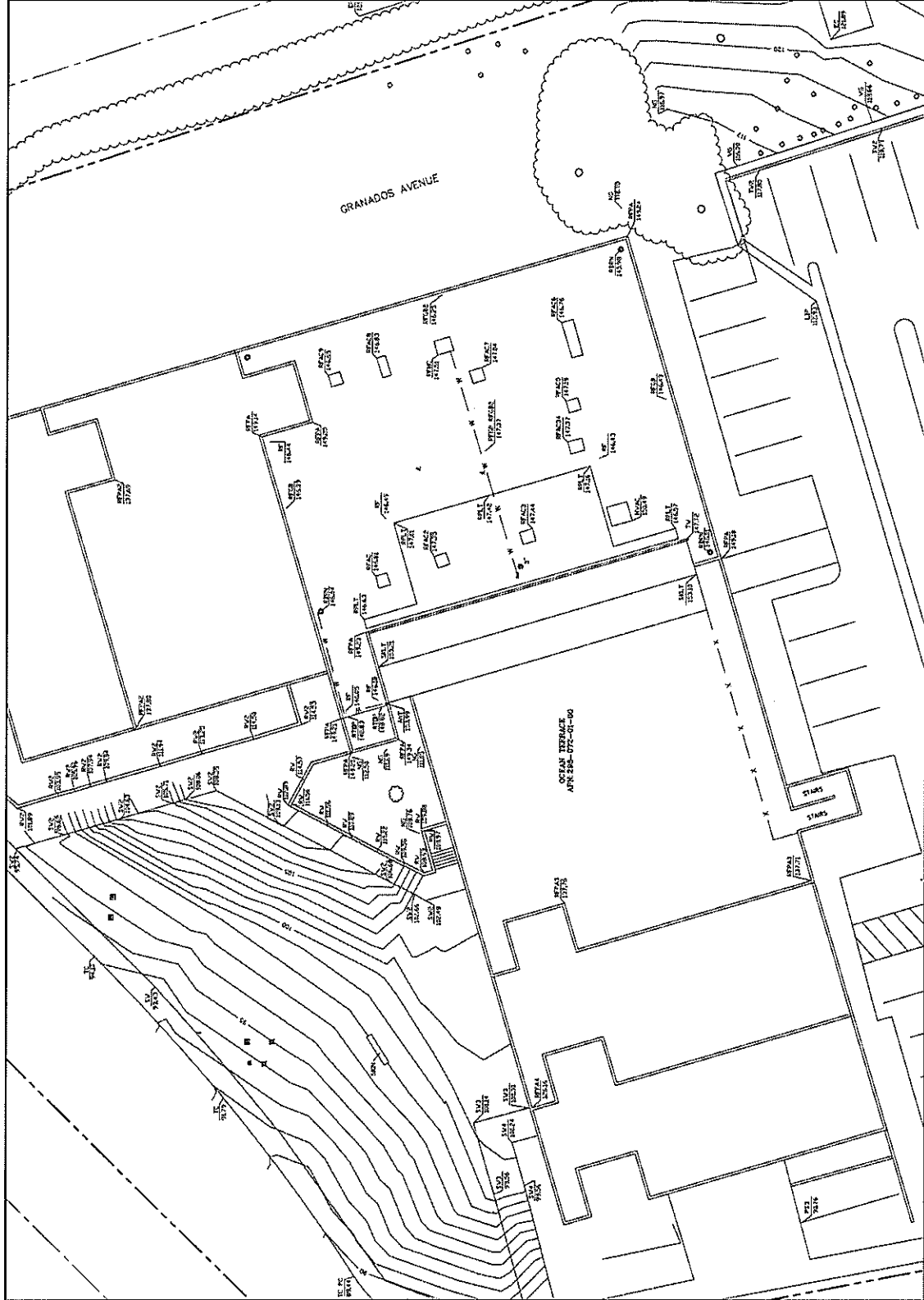


### LEGEND

- These symbols appear as they are found in the sheets:
- FINISH ELEVATION
  - STORM DRAIN ROOF
  - ROOF OUTLET
  - ROOF VENT
  - AIR CONDITIONER
  - HANDY CAR GARAGE
  - TREE DECK/DOCK
  - BRUSH
  - WATER LINE
  - ANTENNA W/TV
  - ELEC
  - EDGE OF CONCRETE
  - EDGE OF PAVEMENT
  - UP
  - DOWN
  - UP US OUTLET
  - GROUND SLOPE ELEVATION
  - FLOOR
  - ROOF FLOOR
  - ROOF GRADE BREAK
  - ROOF PLANT
  - ROOF PLATFORM
  - ROOF WALK
  - ROOF VENT
  - ROOF LIGHT
  - ROOF
  - TOP OF WALL
  - V-CUTTER
  - BOUNDARY LINE
  - CENTER LINE
  - PROPERTY LINE
  - RIGHT-OF-WAY LINE
  - EASEMENT LINE
  - FENCE LINE

### LEGEND

- 1) This is not a boundary survey. This is a specialized topographic map. The property lines and easements shown hereon are not intended to be used as a legal instrument. The surveyor has made no attempt to locate or identify any of the property lines or easements shown hereon. No title research was performed by Floyd Surveying.
- 2) Any change in grade to the information on this plan, without the approval of Floyd Surveying, renders this plan, void of any and all liability.
- 3) These drawings & specifications are the property & copyright of Floyd Surveying & shall not be used on any other work without the written consent of Floyd Surveying. The surveyor's preference over local & state laws shall be enforced on the job site. Any discrepancy shall be brought to the notice of the Surveyor prior to commencement of any work.
- 4) Field survey completed on SEPTEMBER 27, 2016.



<b>GENERAL NOTES</b>	
	<b>TOPOGRAPHIC SURVEY</b> <span style="font-size: 2em; font-weight: bold;">B02</span>
<b>DETAIL SITE PLAN</b> SCALE: 1"=40' DATE: 10/27/16 DRAWN BY: DAF	<b>at&amp;t</b> LAND SURVEY 201 TRADE STREET SAN DIEGO, CA 92101
<b>DCI PACIFIC</b> A ITC WORKS ARCHITECTURE, ENGINEERING, CONSULTING 32 EXECUTIVE PARK, SUITE 110, IRVINE, CA 92614 PHONE: (949) 475-1000 FAX: (949) 475-1001	<b>LOMAS SANTA FE</b> S00925 201 LOMAS SANTA FE DRIVE SOLANA BEACH, CA 92075
<b>FLOYD SURVEYING</b> 3405 GALLERON STREET IRVINE, CA 92612 (949) 475-1000 EMAIL: floyd@floydsurveying.com	SCALE: AS SHOWN REVISIONS BY: DAF DATE: 10/27/16

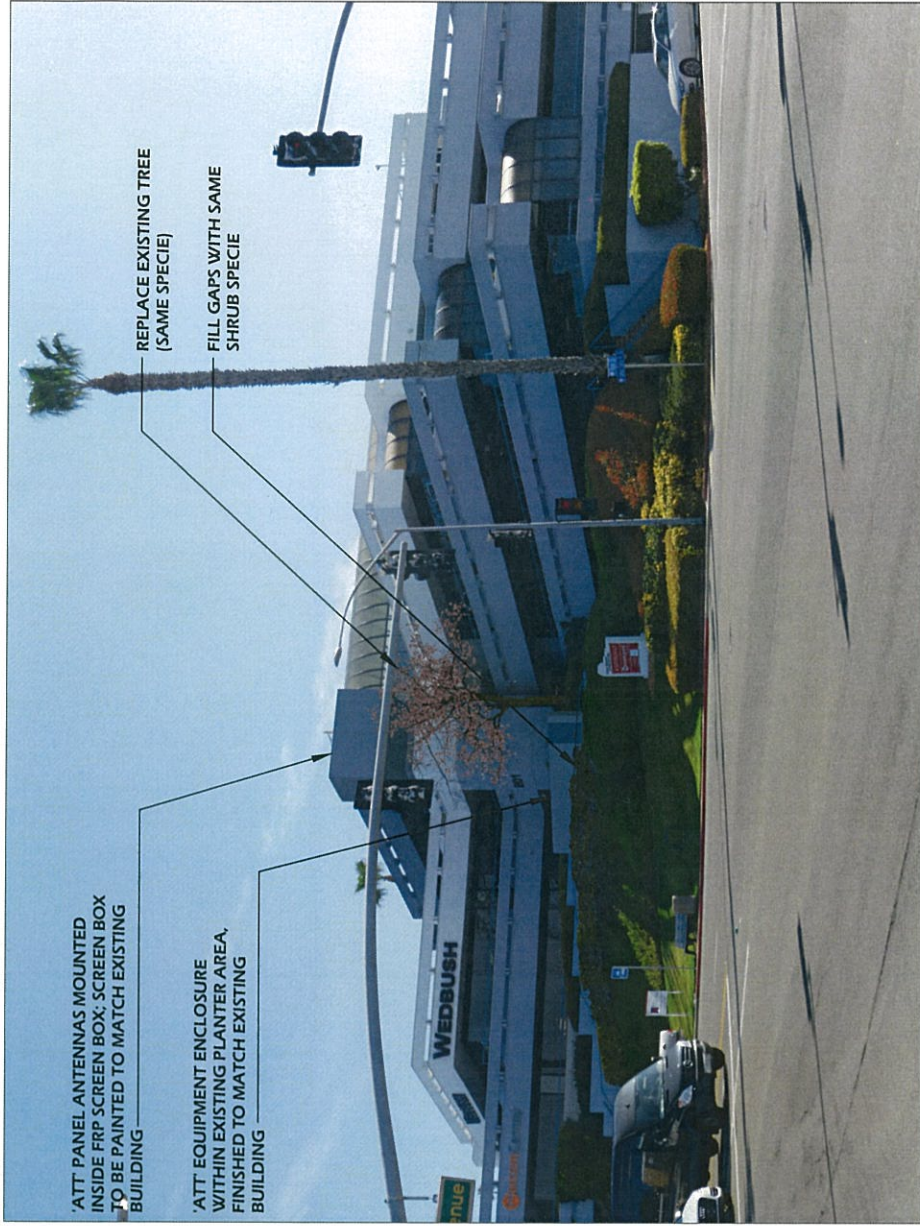


# AERIAL MAP



COPYRIGHT: GOOGLE MAPS, 2018

# PROPOSED



# EXISTING



**DCI PACIFIC**  
**A|E|C WORKS**  
 ARCHITECTURE | ENGINEERING | CONSULTING  
 37 EXECUTIVE PARKS, SUITE 1000 | SAN JOSE, CA 95134  
 T 408.975.1000 | F 408.975.1001 |



**LOMAS SANTA FE**  
**SD0925**  
 201 LOMAS SANTA FE DRIVE  
 SOLANA BEACH, CA 92075

**VIEW**  
**A**

**SHEET**  
**1 / 3**



# AERIAL MAP



COPYRIGHT: GOOGLE MAPS, 2018

# PROPOSED



# EXISTING



**DCI PACIFIC**  
**AIE|C WORKS**  
 ARCHITECTURE | ENGINEERING | CONSULTING  
 32 EXECUTIVE PARK | SUITE 110 | IRVINE | CA 92614  
 714.972.1000 | 714.475.1001 |



**LOMAS SANTA FE**  
**SD0925**  
 201 LOMAS SANTA FE DRIVE  
 SOLANA BEACH, CA 92075

VIEW

**B**

SHEET

**2 / 3**



# STAFF REPORT CITY OF SOLANA BEACH

**TO:** Honorable Mayor and City Councilmembers  
**FROM:** Gregory Wade, City Manager  
**MEETING DATE:** February 14, 2018  
**ORIGINATING DEPT:** Community Development Department  
**SUBJECT:** **Public Hearing: Request for DRP to Convert an Existing Commercial Retail Tenant Space to a Café with an Outdoor Patio at 439 S. Cedros Avenue (Case # 17-17-29 Applicants: 439 Cedros, LLC; APN: 298-091-09; Resolution No. 2018-014)**

---

## **BACKGROUND:**

The Applicant, 439 Cedros, LLC, is requesting City Council approval of a Development Review Permit (DRP) to convert 1,291 square feet of an existing commercial building to a café use and construct a new 540 square foot outdoor patio in front of the café for an outdoor seating area in the southeast corner of the property. In order to provide the additional required off-street parking for the café use and the outdoor seating area, the Applicant has obtained a lease for the exclusive use of 7,660 square feet of the North County Transit District's (NCTD) property directly west of the property. On this leased area, a new parking lot would be created providing 13 new parking spaces and required landscaping. The existing nonconforming parking onsite will remain in front of the existing buildings. The building would remain the same height at approximately 14 feet above the existing grade except for a proposed roof overhang/architectural feature where the Applicant is proposing accordion doors to provide access from the interior café space to the proposed outdoor patio. This feature will be 15.75 feet above the existing grade. The 23,633 square-foot lot is located at 435-439 South Cedros Avenue within the Special Commercial (SC) Zone and the Highway 101 Specific Plan (Hwy 101 SP) area.

The project would require grading in the amounts of 12 cubic yards of cut and recompaction below the proposed outdoor seating area and 8 cubic yards of fill for the proposed landscaping planters in the new parking lot and around the outdoor seating. The project requires a DRP according to SBMC 17.68.040(B)(1)(I) because the project consists of "a new commercial development or construction (including any structural addition to existing development) located within any commercial zone which results in

CITY COUNCIL ACTION:

---

---

---



*an increase of more than 500 feet of gross floor area or to the overall building envelope.”*

The issue before the Council is whether to approve, approve with conditions, or deny the Applicant's request as contained in Resolution 2018-014 (Attachment 1).

### **DISCUSSION:**

The 23,633 square foot lot is currently developed with two structures, the northern building, consisting of 6,253 square feet and the southern building, consisting of 3,744 square feet. The project site has been previously used for a commercial retail and storage building. The Applicant purchased the site and processed a building permit for a tenant improvement in order to update the buildings and to separate the existing commercial retail and storage space into commercial retail and office tenant spaces and maintain the existing nonconforming parking lot in front of the building. Each building would have tenant spaces that front along S. Cedros Avenue and some tenant spaces that are accessed from the rear or western elevation of each building. The property has 10 existing parking spaces located in front of the buildings that are existing nonconforming as they do not comply with the current regulations of the Off-Street Parking Design Manual (OSPDM). The parking lot has one entry at the center of the lot that allows for one way traffic through the existing parking area to an exit at the northeast corner of the lot. The center driveway entry also provides access behind the existing structures to the NCTD property west of the lot. The center driveway, between the buildings, slopes downward so that the finished floor of the tenant spaces toward the back or west side of the buildings is approximately 7 feet lower than the finished floor of the tenant spaces that have frontage on S. Cedros Avenue.

While under construction for the tenant improvement, the Applicant submitted this application to convert 1,291 square feet of the southern building into a café and to construct a new patio at the southeast corner of the building for outdoor seating. The proposed hours of operation would be 6:00am to 10:00pm seven days a week in order to serve breakfast, lunch and dinner. The proposed café would not have a separate bar area but beer and wine would be served. The Applicant is not proposing amplified music, dancing or and live entertainment and a condition of approval has been added to prohibit dancing or live entertainment unless the Applicant receives approval of an Entertainment Establishment license. The project is also conditioned to require the approval of a Conditional Use Permit if, in the future, the Applicant decides to install a separate bar area in the café space or sell alcoholic beverages for off-site consumption.

The Applicant has provided documentation that they have a lease for the exclusive use of 7,660 square feet of the NCTD property directly west of the subject lot. In order to provide the additional parking for the café use, the Applicant proposes to construct a new parking lot on the NCTD lot that would provide 13 parking spaces for the café use and three additional spaces for the retail tenant spaces. Landscaping is also proposed around the proposed outdoor seating and the new parking lot. The Engineering Department would require a dedication of approximately 2,135 square feet along S.

Cedros Avenue so that the public right-of-way would end at the western side of the existing sidewalk. The project plans are provided in Attachment 2.

Table 1 (next page) provides a comparison of the Solana Beach Municipal Code (SBMC) applicable zoning regulations with the Applicant's proposed design.

<b>Table 1</b>			
<b>LOT INFORMATION</b>			
<b>Property Address:</b>	435-439 S. Cedros Ave.	<b>Zoning Designation:</b>	Special Commercial (SC)
<b>Lot Size (Net):</b>	21,498 ft <sup>2</sup>	<b>Setbacks:</b>	<b>Required</b> <b>Proposed</b>
<b>Max. Allowable Floor Area:</b>	1.0 or 21,498 ft <sup>2</sup>	Front (E)	10 ft.      25 ft.
<b>Proposed Floor Area:</b>	9,997 ft <sup>2</sup>	Interior Side (N)	0 ft.      2'-1" ft.
<b>Below Max. Floor Area by:</b>	15,792 ft <sup>2</sup>	Interior Side (S)	0 ft.      0 ft.
<b>Max. Allowable Height:</b>	25 ft <sup>2</sup>	Rear (W)	0 ft.      0- approx. 27 ft.
<b>Max. Proposed Height:</b>	15.75 ft.		
	94.19 MSL		
<b>Overlay Zone(s):</b>	HWY 101 SP		
<b>PROPOSED PROJECT INFORMATION</b>			
<b>Square Footage Breakdown:</b>		<b>Required Permits:</b>	
Northern Commercial Bldg:	6,253 ft <sup>2</sup>	DRP: A DRP is required for a new commercial development or construction (including any structural addition to existing development) located within any commercial zone which results in an increase of more than 500 feet of gross floor area or to the overall building envelope.	
Southern Bldg:			
Retail Use:	535 ft <sup>2</sup>		
Office Use:	1,981 ft <sup>2</sup>		
Interior Café Use:	1,291 ft <sup>2</sup>		
Outdoor Café Seating:	540 ft <sup>2</sup>		
<b>Total ft<sup>2</sup> South Building:</b>	<b>4,284 ft<sup>2</sup></b>		
<b>Total ft<sup>2</sup> Onsite:</b>	<b>10,537 ft<sup>2</sup></b>		
<b>Proposed Grading:</b> approximately 20 cubic yards of grading which would include 12 cubic yards of cut and recompaction below the concrete for the new outdoor seating patio and 8 cubic yards of fill for the new proposed landscape planter areas.			
<b>Proposed Parking:</b> 10 existing non-conforming parking spaces to remain in front of the existing structures and 16 new parking spaces provided behind the property on the leased NCTD property.		<b>Existing Development:</b> Two existing commercial retail/storage buildings to remain.	

Staff has prepared draft findings for approval of the project in the attached Resolution 2018-014 for Council's consideration based upon the information in this report. The applicable SBMC sections are provided in italicized text and conditions from the Community Development, Engineering, and Fire Departments are incorporated in the Resolution of Approval. The Council may direct Staff to modify the Resolution to reflect the findings and conditions it deems appropriate as a result of the public hearing process. If the Council determines the project is to be denied, Staff will prepare a Resolution of Denial for adoption at a subsequent Council meeting.

The following is a discussion of the findings for a DRP as each applies to the proposed project as well as references to recommended conditions of approval contained in Resolution 2018-014.

#### Development Review Permit Compliance (SBMC Section 17.68.40):

A DRP is required for a new commercial development or construction (including any structural addition to existing development) located within any commercial zone which results in an increase of more than 500 feet of gross floor area or to the overall building envelope.

In addition to meeting zoning requirements, the project must also be found in compliance with development review criteria. The following is a list of the development review criteria topics:

1. Relationship with Adjacent Land Uses
2. Building and Structure Placement
3. Landscaping
4. Roads, Pedestrian Walkways, Parking, and Storage Areas
5. Grading
6. Lighting
7. Usable Open Space

The Council may approve, or conditionally approve, a DRP only if all of the findings listed below can be made. Resolution 2018-014 provides the full discussion of the findings.

1. The proposed development is consistent with the general plan and all applicable requirements of the zoning ordinance including special regulations, overlay zones, and specific plans.
2. The proposed development complies with the development review criteria.
3. All required permits and approvals issued by the city, including variances, conditional use permits, comprehensive sign plans, and coastal development permits have been obtained prior to or concurrently with the development review permit.
4. If the development project also requires a permit or approval to be issued by a state or federal agency, the city council may conditionally approve the development review permit upon the Applicants obtaining the required permit or approval from the other agency.

If the above findings cannot be made, the Council shall deny the DRP. The following is a discussion of the applicable development review criteria as they relate to the proposed project.

#### Relationship with Adjacent Land Uses:

The property is located within the SC Zone. Other properties located to the north, south and east are also within the SC Zone and developed with one- and two-story commercial structures. The property directly west is the NCTD railroad right-of-way, a portion of which is leased by the property owner for their proposed parking area. The project site is currently developed with two single-story structures.

The project, as designed, is consistent with the permitted uses for the SC Zone as described in SBMC Sections 17.28.010 and 17.12.020. The property is designated Special Commercial in the General Plan and intended to provide a range of commercial and light industrial uses that have minimal disturbance to nearby single-family residential neighborhoods. The proposed development could be found to be consistent with the objectives of the General Plan as it encourages the development of commercial land uses which strengthen the City's economic base and offer a range of commercial enterprises to meet the needs of residents and visitors. The General Plan also encourages neighborhood serving restaurants, including outdoor dining/sidewalk cafes in mixed use areas and along the Highway 101 corridor.

The property is located within the South Cedros District of the Highway 101 Specific Plan and the Coastal Zone. The project has been evaluated, and could be found to be in conformance with, the regulations of the Hwy 101 SP which are discussed further in this report. As a condition of project approval, the Applicant would be required to obtain a Coastal Development Permit, Waiver or Exemption from the California Coastal Commission prior to the issuance of a Building Permit.

#### Building and Structure Placement:

The property is currently developed with two buildings. As previously mentioned, both buildings received building permit approval for tenant improvements and are currently under construction. This application is focused on the southern building where the Applicant proposes to maintain the existing footprint of the building and the existing nonconforming parking in front of the property and to convert one tenant space into a café with outdoor seating. The height of the southern building would remain the same at approximately 14 feet above the existing grade except for a roof overhang/architectural feature that is proposed around the area where the patio would be accessed from the interior café space. This feature would be at a maximum of 15.75 feet above the existing grade. The café use and outdoor seating area would require additional parking and the Applicant proposes to provide that on the NCTD property it leases directly east of the lot. An existing fence around the rear of the property and the leased area of the NCTD property is proposed to remain with the project.

The project would require a dedication across the entire frontage on S. Cedros Avenue that is approximately seven feet wide. The dedication would reduce the lot area to 21,489 square feet. This dedication would put the existing side walk in the public right-of-way instead of on private property. As designed, the proposed project would be in

compliance with the required setbacks for S. Cedros Avenue according to the Hwy 101 SP.

The SC zone allows for a maximum floor area of 1.0 or a maximum of 21,498 square feet of floor area. The floor area of the existing buildings would remain the same. The northern building is 6,253 square feet and would be made up of a mixture of commercial retail and office tenant spaces. The southern building is 3,744 square feet and would be made up of 2,453 square feet of commercial retail and office tenant spaces and the 1,291 square foot café. The proposed 540 square foot patio is not counted in the calculation of floor area but it is counted in the gross floor area when determining required parking for the proposed uses which is discussed later in this report.

The proposed project, as designed, meets the minimum required setbacks and the maximum allowable floor area for the property.

#### Fences, Walls and Retaining Walls:

Within the front yard setback area, the SBMC Section 17.60.070 indicates that fences, walls or any combination thereof, shall be no higher than 42 inches except for an additional 24 inches that is constructed of a material that is 80% open to light. Fences and walls located within the required rear and interior side yard setbacks shall be no higher than 6 feet except where such property abuts a residentially zoned lot.

There is an existing chain link fence along the southern and western property lines that the Applicant is proposing to maintain. At the western property line, the fence is parallel to and set back approximately 10 feet from the western edge of the NCTD right-of-way. The Applicant is proposing to construct a fence along the northern property line to enclose the remainder of the parking area on the west side of the development. This fence is chain link and ranges from approximately 4 feet to 6 feet in height.

Currently, the plans show fences and walls that comply with the requirements of SBMC 17.60.070. If the Applicant decides to modify any of the proposed fences and walls or construct additional fences and walls on the project site, a condition of project approval indicates that they would be required to be in compliance with the Municipal Code.

#### Landscape:

The project is subject to the current water efficient landscaping regulations of SBMC Chapter 17.56. A Landscape Documentation Package is required for new development projects with an aggregate landscape equal to or greater than 500 square feet requiring a building permit, plan check or development review. The Applicant provided a conceptual landscape plan that has been reviewed by the City's third-party landscape architect, who has recommended approval. The Applicant will be required to submit detailed construction landscape drawings that will be reviewed by the City's third-party landscape architect for conformance with the conceptual plan. In addition, the City's third-party landscape architect will perform inspections during the construction phase of the project. A separate condition has been added to require that native or drought-

tolerant and non-invasive plant materials and water-conserving irrigation systems are required to be incorporated into the landscaping to the extent feasible.

#### Parking:

The SC zone indicates that mixed use commercial structures in the South Cedros Avenue district require one off-street parking space per each 312 square feet of gross floor area. Business and professional offices require one space per every 300 square feet of gross floor area. Restaurants and cafés require one off-street parking space for each 143 square feet of gross floor area in a mixed use project. SBMC section 17.52.040 indicates that the gross floor area of a restaurant includes outdoor seating and eating area.

The site has existing parking that is considered nonconforming as it does not comply with the current regulations of the OSPDM. SBMC Section 17.16.110(C) indicates that all nonresidential uses on premises which do not meet the minimum parking requirements as provided in Chapter 17.52 SBMC are subject to the following requirements:

- 1. Any change of use which requires more parking than the previous use shall be allowed only if the full amount of the required parking for the new use is provided. Parking deficiencies associated with other existing uses may be maintained. A change of use which does not require more parking than the previous use shall be allowed and the existing deficiency may be maintained.*
- 2. New structures or structural additions which result in an expansion of less than 50 percent of the existing floor area of the lot shall be allowed only if the required parking for the expansion area is provided. Parking deficiencies for the existing floor area may be maintained*

Prior to the tenant improvement of the buildings, the site was made up of 7,103 square feet of office space and 2,857 square feet of storage which required 33 parking spaces according to the regulations effective today. With the tenant improvement, the entire site would be made up of 4,403 square feet of commercial retail space which would require 14.1 parking spaces. The remainder of the buildings, 5,594 square feet, used for commercial office would require 18.6 parking spaces for a total parking requirement of 32.7 or 33 spaces. There are currently 10 nonconforming parking spaces onsite. Converting 1,291 square feet of the existing building to a café use and constructing a 540 patio for outdoor seating would require 12.8, or 13, parking spaces. According to the code section cited above, the Applicant is allowed to maintain the existing parking nonconformity as long as they can provide all of the required parking for the new use that requires more parking. In order to provide 13 additional spaces, the Applicant has entered into a lease with the NCTD, which expires June 30, 2051, to construct a new parking lot on the property directly east of the project site. The parking lot would provide 16 parking spaces that are in compliance with the regulations of the OSPDM for minimum required dimensions, back up distance and required landscaping. A condition of project approval has been added to indicate that the Applicant is required to provide

comparable new off-street parking spaces in the event the lease for the spaces is terminated for any reason, otherwise the café use would have to be terminated within 6 months after the parking lease termination.

The Applicant received approval for a trash enclosure with the tenant improvement building permit plans and it is also shown on the attached plans. The trash enclosure will be just south of parking space #26 at the southwest corner of the site. The width of this parking space has been increased by two feet in order to be in compliance with the OSPDM.

#### Grading:

The project includes grading in the amount of 20 cubic yards. 12 cubic yards of cut and recompaction will take place below the proposed outdoor seating area and an additional 8 cubic yards of fill is proposed for the new landscape planters that will surround the proposed parking lot and the proposed outdoor seating area.

#### Lighting:

A condition of project approval is that all new exterior lighting fixtures comply with the City-Wide Lighting Regulations of the Zoning Ordinance (SBMC 17.60.060). All light fixtures shall be shielded so that no light or glare is transmitted or reflected in such concentrated quantities or intensities as to be detrimental to the surrounding area.

#### Usable Open Space:

The project consists of changing the use of an existing retail/storage building to a café, constructing a patio for outdoor seating, and site improvements and landscaping to provide the required parking, therefore, usable open space and recreational facilities are neither proposed nor required according to SBMC Section 17.20.040.

#### Comprehensive Sign Plan:

The SBMC indicates that a comprehensive sign plan is required for commercial centers consisting of four or more tenant or occupant spaces. The proposed project includes 11 retail or office tenant spaces and one café that will have signage. A comprehensive sign plan was prepared to be evaluated with the project and is provided in Attachment 2. A visual representation of the proposed signs is shown on sheet CSP-2 of the attached plans provided in Attachment 2. The comprehensive sign ordinance and the HWY 101 SP allow for a maximum signage allowance for wall signs of one square foot of signage per one linear foot of building frontage as well as a 32 square foot freestanding sign. The maximum area per freestanding sign can be increased to a maximum of 66 square feet where the sign serves multiple tenants of a community shopping or office center. Building frontage is the lineal footage of all building elevations containing a public entrance and which face a public street or on-premises parking lot, excluding driveways and aisles. The building has approximately 198 feet 9 inches of frontage along the west elevation where it abuts S. Cedros Avenue as well as 76 feet 2 inches along the western elevation that fronts the rear parking lot. Therefore, a total of 366 square feet

of wall signage is allowed. The total amount of signage is divided by the business frontage, or the portion of an individual tenant space.

As designed, there are potential locations shown for 26 wall signs on the buildings for a total of 195.7 square feet on the east elevation and 144 square feet on the west elevation of the buildings. A maximum of two signs for each business is permitted according to the HWY 101 SP. The total proposed wall signage according to the sign plan is 339.7 square feet, which is below the maximum allowable square footage of 366 square feet.

The Applicant is also proposing a freestanding sign in the landscaped area in front of the outdoor patio. The freestanding sign is proposed to be a maximum of 5 feet tall and 5'-4" wide with a total of 32 square feet of signage.

A condition of approval has been added to the attached resolution that indicates that the tenants are required to apply for a building/sign permit prior to the installation of any sign and receive landlord approval for the proposed signage. Any proposed signage that is not in compliance with the approved comprehensive sign plan will require the Applicant or tenant to process a comprehensive sign plan modification under the discretion of the Community Development Director.

#### Public Hearing Notice:

Notice of the City Council Public Hearing for the project was published in the Union Tribune more than 10 days prior to the public hearing. The same public notice was mailed to property owners and occupants within 300 feet of the proposed project site on February 1, 2018. As of the date of preparation of this Staff Report, Staff received one letter in support of the project (Attachment 3).

Conditions from the Planning, Engineering, and Fire Departments have been incorporated into the Resolution of Approval. In conclusion, the proposed project, as conditioned, could be found to be consistent with the Zoning regulations and the General Plan.

#### **CEQA COMPLIANCE STATEMENT:**

The project is exempt from the California Environmental Quality Act (CEQA) pursuant to Section 15303 of the State CEQA Guidelines. Class 3 consists of construction and location of limited numbers of new, small facilities or structures. Examples of this exemption include a store, motel, office, restaurant or similar structure not using a significant amount of hazardous substances and not exceeding 2,500 square feet in floor area.

#### **FISCAL IMPACT:** N/A

#### **WORK PLAN:** N/A



**OPTIONS:**

- Approve Staff recommendation adopting the attached Resolution 2018-014.
- Approve Staff recommendation subject to additional specific conditions necessary for the City Council to make all required findings for the approval of a DRP.
- Deny the project if all required findings for the DRP cannot be made.


**DEPARTMENT RECOMMENDATION:**

The proposed project meets the minimum zoning requirements under the SBMC, may be found to be consistent with the General Plan and may be found, as conditioned, to meet the discretionary findings required as discussed in this report to approve a DRP. Therefore, Staff recommends that the City Council:

1. Conduct the Public Hearing: Open the Public Hearing, Report Council Disclosures, Receive Public Testimony, and Close the Public Hearing.
2. Find the project exempt from the California Environmental Quality Act pursuant to Section 15303 of the State CEQA Guidelines; and
3. If the City Council makes the requisite findings and approves the project, adopt Resolution 2018-014 conditionally approving a DRP to convert 1,291 square feet of an existing commercial building to a café, construct a new 540 square foot outdoor seating area and a new parking lot to provide 16 new parking spaces at 439 S. Cedros Avenue.

**CITY MANAGER'S RECOMMENDATION:**

Approve Department Recommendation.

  
\_\_\_\_\_  
Gregory Wade, City Manager

Attachments:

1. Resolution 2018-014
2. Project Plans
3. Letter of Support

**RESOLUTION NO. 2018-014**

**A RESOLUTION OF THE CITY COUNCIL OF THE CITY OF SOLANA BEACH, CALIFORNIA, CONDITIONALLY APPROVING A DEVELOPMENT REVIEW PERMIT TO CONVERT 1,291 SQUARE FEET OF AN EXISTING COMMERCIAL RETAIL AND OFFICE BUILDING TO A CAFÉ USE, CONSTRUCT A NEW 540 SQUARE FOOT PATIO FOR OUTDOOR SEATING, CONSTRUCT A NEW PARKING LOT WITH 13 SPACES AND REQUIRED LANDSCAPING AND A COMPREHENSIVE SIGN PLAN ON PROPERTY AT 435-439 S. CEDROS AVENUE, SOLANA BEACH**

**APPLICANTS: 439 CEDROS, LLC  
CASE NO.: 17-17-29 DRP**

**WHEREAS**, 439 Cedros, LLC (hereinafter referred to as "Applicant"), has submitted an application for a Development Review Permit (DRP) pursuant to Title 17 (Zoning) of the Solana Beach Municipal Code (SBMC); and

**WHEREAS**, the public hearing was conducted pursuant to the provisions of Solana Beach Municipal Code Section 17.72.030; and

**WHEREAS**, at the public hearing on February 14, 2018, the City Council received and considered evidence concerning the proposed application; and

**WHEREAS**, the City Council found the application request exempt from the California Environmental Quality Act pursuant to Section 15303 of the State CEQA Guidelines; and

**WHEREAS**, this decision is based upon the evidence presented at the hearing, and any information the City Council gathered by viewing the site and the area as disclosed at the hearing.

**NOW THEREFORE**, the City Council of the City of Solana Beach, California, does resolves as follows:

- I. That the foregoing recitations are true and correct.
- II. That the request for a DRP to convert 1,291 square feet of an existing commercial retail and office building to a café, construct a new 540 square foot patio for outdoor seating, construct a new parking lot with 13 spaces for the café use, install required landscaping and a comprehensive sign plan for the entire site at 439 S. Cedros Avenue, is conditionally approved based upon the following Findings and subject to the following Conditions:

### III. FINDINGS

A. In accordance with Section 17.68.040 (Development Review Permit) of the City of Solana Beach Municipal Code, the City Council finds the following:

- I. *The proposed project is consistent with the General Plan and all applicable requirements of SBMC Title 17 (Zoning Ordinance), including special regulations, overlay zones and specific plans.*

General Plan Consistency: The project, as conditioned, is consistent with the City's General Plan designation of Special Commercial (SC), which allows for the restaurant/café use. The development is also consistent with the objectives of the General Plan as it encourages the development of commercial land uses which strengthen the City's economic base and offer a range of commercial enterprises to meet the needs of residents and visitors. The General Plan also encourages neighborhood serving restaurants, including outdoor dining/sidewalk cafes in mixed use areas and along the Highway 101 corridor.

Zoning Ordinance Consistency: The project is consistent with all applicable requirements of the Zoning Ordinance (Title 17) (SBMC 17.28.030) which delineates maximum allowable Floor Area Ratio (FAR), Permitted Uses and Structures (SBMC Section 17.28.020) which provides for uses of the property for a single-family residence. Further, the project adheres to all property development regulations established in the Highway 101 Specific Plan (HWY 101 SP).

The project is consistent with the provisions for minimum yard dimensions (i.e., setbacks) and the maximum allowable Floor Area Ratio (FAR), maximum building height, and parking requirements.

- II. *The proposed development complies with the following development review criteria set forth in Solana Beach Municipal Code Section 17.68.040.F:*

- a. *Relationship with Adjacent Land Uses: The development shall be designed in a manner compatible with and complementary to existing development in the immediate vicinity of the project site and the surrounding neighborhood. The development as proposed shall also be compatible in scale, apparent bulk, and massing with such existing development in the surrounding neighborhood. Site planning on or near the perimeter of the development shall give consideration to the protection of surrounding areas from potential adverse effects.*

The property is located within the SC Zone. Other properties located to the north, south and east are also within the SC Zone and developed with one- and two-story commercial

structures. The property directly west is the NCTD railroad right-of-way, a portion of which is leased by the property owner for their proposed parking area. The project site is currently developed with two single-story structures.

The project, as designed, is consistent with the permitted uses for the SC Zone as described in SBMC Sections 17.28.010 and 17.12.020. The property is designated Special Commercial in the General Plan and intended provide to a range of commercial and light industrial uses that have minimal disturbance to nearby single-family residential neighborhoods. The proposed development could be found to be consistent with the objectives of the General Plan as it encourages the development of commercial land uses which strengthen the City's economic base and offer a range of commercial enterprises to meet the needs of residents and visitors. The General Plan also encourages neighborhood serving restaurants, including outdoor dining/sidewalk cafes in mixed use areas and along the Highway 101 corridor.

The property is located within the South Cedros District of the Highway 101 Specific Plan and the Coastal Zone. The project has been evaluated, and could be found to be in conformance with, the regulations of the Hwy 101 SP which are discussed further in this report. As a condition of project approval, the Applicant would be required to obtain a Coastal Development Permit, Waiver or Exemption from the California Coastal Commission prior to the issuance of a Building Permit.

- b. Building and Structure Placement: Buildings and structures shall be sited and designed to minimize adverse impacts on the surrounding properties and designed in a manner which visually and functionally enhance their intended use and complement existing site topography. Multi-family residential buildings shall be sited to avoid crowding and to allow for a functional use of the space between buildings.*

The property is currently developed with two buildings. As previously mentioned, both buildings received building permit approval for tenant improvements and are currently under construction. This application is focused on the southern building where the Applicant proposes to maintain the existing footprint of the building and the existing nonconforming parking in front of the property and to convert one tenant space into a café with outdoor seating. The height of the southern building would remain the same at approximately 14 feet above the existing grade except for a roof overhang/architectural feature that is proposed around the area where the patio would be

accessed from the interior café space. This feature would be at a maximum of 15.75 feet above the existing grade. The café use and outdoor seating area would require additional parking and the Applicant proposes to provide that on the NCTD property it leases directly east of the lot. An existing fence around the rear of the property and the leased area of the NCTD property is proposed to remain with the project.

The project would require a dedication across the entire frontage on S. Cedros Avenue that is approximately seven feet wide. The dedication would reduce the lot area to 21,489 square feet. This dedication would put the existing side walk in the public right-of-way instead of on private property. As designed, the proposed project would be in compliance with the required setbacks for S. Cedros Avenue according to the Hwy 101 SP.

The SC Zone allows for a maximum floor area of 1.0 or a maximum of 21,498 square feet of floor area. The floor area of the existing buildings would remain the same. The northern building is 6,253 square feet and would be made up of a mixture of commercial retail and office tenant spaces. The southern building is 3,744 square feet and would be made up of 2,453 square feet of commercial retail and office tenant spaces and the 1,291 square foot café. The proposed 540 square foot patio is not counted in the calculation of floor area but it is counted in the gross floor area when determining required parking for the proposed uses which is discussed later in this report.

The proposed project, as designed, meets the minimum required setbacks and the maximum allowable floor area for the property.

- c. *Landscaping: The removal of significant native vegetation shall be minimized. Replacement vegetation and landscaping shall be compatible with the vegetation of the surrounding area. To the maximum extent practicable, landscaping and plantings shall be used to screen parking areas, storage areas, access roads, and other service uses of the site. Trees and other large plantings shall not obstruct significant views when installed or at maturity. Drought tolerant plant materials and water conserving irrigation systems shall be incorporated into all landscaping plans.*

The project is subject to the current water efficient landscaping regulations of SBMC Chapter 17.56. A Landscape Documentation Package is required for new development

projects with an aggregate landscape equal to or greater than 500 square feet requiring a building permit, plan check or development review. The Applicant provided a conceptual landscape plan that has been reviewed by the City's third-party landscape architect, who has recommended approval. The Applicant will be required to submit detailed construction landscape drawings that will be reviewed by the City's third-party landscape architect for conformance with the conceptual plan. In addition, the City's third-party landscape architect will perform inspections during the construction phase of the project. A separate condition has been added to require that native or drought-tolerant and non-invasive plant materials and water-conserving irrigation systems are required to be incorporated into the landscaping to the extent feasible.

- d. Roads, Pedestrian Walkways, Parking and Storage Areas: Any development involving more than one building or structure shall provide common access roads and pedestrian walkways. Parking and outside storage areas, where permitted, shall be screened from view, to the extent feasible, by existing topography, by the placement of buildings and structures, or by landscaping and plantings.*

The SC zone indicates that mixed use commercial structures in the South Cedros Avenue district require one off-street parking space per each 312 square feet of gross floor area. Business and professional offices require one space per every 300 square feet of gross floor area. Restaurants and cafés require one off-street parking space for each 143 square feet of gross floor area in a mixed use project. SBMC section 17.52.040 indicates that the gross floor area of a restaurant includes outdoor seating and eating area.

The site has existing parking that is considered nonconforming as it does not comply with the current regulations of the OSPDM. SBMC Section 17.16.110(C) indicates that all nonresidential uses on premises which do not meet the minimum parking requirements as provided in Chapter 17.52 SBMC are subject to the following requirements:

1. Any change of use which requires more parking than the previous use shall be allowed only if the full amount of the required parking for the new use is provided. Parking deficiencies associated with other existing uses may be maintained. A change of use which does not require more parking than the previous use shall be allowed and the existing deficiency may be maintained.

2. New structures or structural additions which result in an expansion of less than 50 percent of the existing floor area of the lot shall be allowed only if the required parking for the expansion area is provided. Parking deficiencies for the existing floor area may be maintained

Prior to the tenant improvement of the buildings, the site was made up of 7,103 square feet of office space and 2,857 square feet of storage which required 33 parking spaces according to the regulations effective today. With the tenant improvement, the entire site would be made up of 4,403 square feet of commercial retail space which would require 14.1 parking spaces. The remainder of the buildings, 5,594 square feet, used for commercial office would require 18.6 parking spaces for a total parking requirement of 32.7 or 33 spaces. There are currently 10 nonconforming parking spaces onsite. Converting 1,291 square feet of the existing building to a café use and constructing a 540 patio for outdoor seating would require 12.8, or 13, parking spaces. According to the code section cited above, the Applicant is allowed to maintain the existing parking nonconformity as long as they can provide all of the required parking for the new use that requires more parking. In order to provide 13 additional spaces, the Applicant has entered into a lease with the NCTD, which expires June 30, 2051, to construct a new parking lot on the property directly east of the project site. The parking lot would provide 16 parking spaces that are in compliance with the regulations of the OSPDM for minimum required dimensions, back up distance and required landscaping. A condition of project approval has been added to indicate that the Applicant is required to provide comparable new off-street parking spaces in the event the lease for the spaces is terminated for any reason, otherwise the café use would have to be terminated within 6 months after the parking lease termination.

The Applicant received approval for a trash enclosure with the tenant improvement building permit plans and it is also shown on the attached plans. The trash enclosure will be just south of parking space #26 at the southwest corner of the site. The width of this parking space has been increased by two feet in order to be in compliance with the OSPDM.

- e. *Grading: To the extent feasible, natural topography and scenic features of the site shall be retained and incorporated into the proposed development. Any grading or earth-moving operations in connection with the proposed development shall be planned and executed so as to blend with the existing*

*terrain both on and adjacent to the site. Existing exposed or disturbed slopes shall be landscaped with native or naturalized non-native vegetation and existing erosion problems shall be corrected.*

The project includes grading in the amount of 20 cubic yards of grading. 12 cubic yards of cut and recompaction will take place below the proposed outdoor seating area and an additional 8 cubic yards of fill is proposed for the new landscape planters that will surround the proposed parking lot and the proposed outdoor seating area.

- f. Lighting: Light fixtures for walkways, parking areas, driveways, and other facilities shall be provided in sufficient number and at proper locations to assure safe and convenient nighttime use. All light fixtures shall be appropriately shielded so that no light or glare is transmitted or reflected in such concentrated quantities or intensities as to be detrimental to the surrounding areas per SBMC 17.60.060 (Exterior Lighting Regulations).*

A condition of project approval is that all new exterior lighting fixtures comply with the City-Wide Lighting Regulations of the Zoning Ordinance (SBMC 17.60.060). All light fixtures shall be shielded so that no light or glare is transmitted or reflected in such concentrated quantities or intensities as to be detrimental to the surrounding area.

- g. Usable Open Space: Recreational facilities proposed within required usable open space shall be located and designed to maintain essential open space values.*

The project consists of changing the use of an existing retail/storage building to a café, constructing a patio for outdoor seating, and site improvements and landscaping to provide the required parking, therefore, usable open space and recreational facilities are neither proposed nor required according to SBMC Section 17.20.040.

- III. All required permits and approvals including variances, conditional use permits, comprehensive sign plans, and coastal development permits have been obtained prior to or concurrently with the development review permit.*

All required permits, including the required comprehensive sign plan, are being processed concurrently with the Development Review Permit.



- IV. *If the development project also requires a permit or approval to be issued by a state or federal agency, the city council may conditionally approve the development review permit upon the Applicant obtaining the required permit or approval from the other agency.*

The Applicant shall obtain approval from the California Coastal Commission prior to issuance of Building Permits.

#### IV. CONDITIONS

Prior to use or development of the property in reliance on this permit, the Applicant shall provide for and adhere to the following conditions:

A. Community Development Department Conditions:

- I. The Applicant shall pay required Public Facilities Fees and the Transportation Impact Fee (TIF) as established by SBMC Section 17.72.020 and Resolution 1987-36 and Ordinance 479.
- II. Building Permit plans must be in substantial conformance with the architectural plans presented to the City Council on February 14, 2018, and located in the project file with a submittal date of February 6, 2017.
- III. Prior to requesting a framing inspection, the Applicant shall be required to submit a height certification, signed by a licensed land surveyor, certifying that the building envelope does not exceed 16 feet in height from the existing grade.
- IV. Any proposed onsite fences, walls and retaining walls and any proposed railing located on top, or any combination thereof, shall comply with applicable regulations of SBMC Section 17.60.070.
- V. The Applicant shall obtain required California Coastal Commission (CCC) approval of a Coastal Development Permit, Waiver or Exemption as determined necessary by the CCC, prior to the issuance of a grading or building permit.
- VI. The Applicant shall submit detailed construction landscape drawings that will be reviewed by the City's third-party landscape architect and shall be in substantial conformance with the conceptual plan presented to the City Council on February 14, 2018. In addition, the City's third-party landscape architect will perform a final inspection to verify substantial conformance onsite prior to final occupancy.
- VII. Native or drought tolerant and non-invasive plant materials and water conserving irrigation systems shall be incorporated into any proposed landscaping and compatible with the surrounding area to the extent

feasible.

- VIII. Any new exterior lighting fixtures shall be in conformance with the City-Wide Lighting Regulations of SBMC 17.60.060.
- IX. All light fixtures shall be appropriately shielded so that no light or glare is transmitted or reflected in such concentrated quantities or intensities that render them detrimental to the surrounding area. Prior to dispensing of any alcoholic beverage on-site, the Applicant shall demonstrate to the satisfaction of the Community Development Director, application and approval of an applicable alcohol beverage permit from the State of California Alcohol Beverage Control (ABC).
- X. Each tenant shall apply for a building/sign permit prior to the installation of any sign in compliance with the approved comprehensive sign plan and show proof of landlord approval for the proposed signage.
- XI. The Applicant shall abide by all ABC conditions. Should the conditions of approval imposed by ABC be more restrictive than those of this DRP, the ABC condition(s) shall prevail.
- XII. Any change to the alcohol sales license issued by the Department of Alcoholic Beverage Control shall be subject to the prior review and approval of the Community Development Director for conformance with this permit.
- XIII. The businesses shall comply with the sound level limits established by Solana Beach Municipal Code Section 7.34.040 during hours of operation.
- XIV. The café shall only be open for service during the hours of 6:00am and 10:00 pm.
- XV. Live entertainment is not permitted with this project approval. Should the Applicant desire to have live entertainment at this establishment, the Applicant shall apply for and obtain an Entertainment Establishment License prior to any live entertainment.
- XVI. The on-site parking lot lighting is required to remain in good working condition from sunset to sunrise.
- XVII. All business identification signage shall comply with the sign regulations established by Solana Beach Municipal Code Section 17.64 (Comprehensive Sign Ordinance). Any proposed signage will require a separate sign and/or building permit approved by the City of Solana Beach.

XVIII. In the event the lease for the parking spaces is terminated for any reason, the Applicant shall provide the same number of off-street parking spaces in a location satisfactory to the City or the café use shall be terminated within 6 months of the termination of the parking lease.

XIX. Each business establishment shall provide a minimum of 125 square feet of work space area per employee. To determine the maximum number of employees, the total tenant space, excluding restrooms, shall be divided by the minimum work space area per employee.

B. Fire Department Conditions:

- I. Building Permits: Building permits are required to change the occupancy from storage structure to restaurant, retail and office space per the current California Building Code.
- II. Fire Resistive Rating and Fire Separation Distance: Building shall be in compliance with CBC Chapter 5-7 in the California Building Code.
- III. FIRE HYDRANTS AND FIRE FLOWS: The Applicant shall provide fire hydrants of a type, number, and location satisfactory to the Solana Beach Fire Department. A letter from the water agency serving the area shall be provided that states the required fire flow is available. Fire hydrants shall be of a bronze type. Multi-family residential or industrial fire hydrants shall have two (2) 4" inch and two (2) 2 ½" inch NST outlets. Residential fire hydrants shall have one (1) 4" inch NST outlet, and one (1) 2 ½" inch NST outlets.
- IV. AUTOMATIC FIRE SPRINKLER SYSTEM: Structures shall be protected by an automatic fire sprinkler system designed and installed to the satisfaction of the Fire Department.
- V. CLASS "A" ROOF: All structures shall be provided with a Class "A" Roof covering to the satisfaction of the Solana Beach Fire Department.

C. Engineering Department Conditions:

- I. The Applicant shall dedicate adequate right-of-way to cover the existing sidewalk along the South Cedros Avenue property frontage. All setbacks and Floor Area Ratio shall be based on the new property line.
- II. Obtain an Encroachment Permit in accordance with Chapter 11.20 of the Solana Beach Municipal Code, prior to the construction of any

improvements within the public right-of-way including, but not limited to, demolition and construction of surface improvements. All proposed improvements within the public right-of-way shall comply with City standards including, but not limited to, the Off-Street Parking Design Manual.

- III. Improvements shall include the removal of the existing driveway approaches and the reconstruction of G 14-A driveway approaches in their place. All cracked, broken, lifted sidewalk panels shall be removed and replaced with new sidewalk panels.
- IV. The existing non-conforming parking stalls (including the existing wheel stops) on the front of the property along South Cedros Avenue shall be the subject of an Encroachment Maintenance Removal Agreement (EMRA) required prior to Final Inspection.
- V. All construction demolition materials shall be recycled according to the City's Construction and Demolition recycling program and an approved Waste Management Plan shall be submitted.
- VI. Construction fencing shall be located on the subject property unless the Applicant has obtained an Encroachment Permit in accordance with Chapter 11.20 of the Solana Beach Municipal Code which allows otherwise.
- VII. The Applicant shall pay in full the one-time sewer capacity/connection fees of \$4,500.00 per Equivalent Dwelling Unit (EDU). The EDU assignment is determined by SBMC 14.08.060.
- VIII. Pay in full the prorated portion of the current annual sewer charge for the remainder of the fiscal year.
- IX. A properly sized grease interceptor shall be installed per the approved plan.
- X. The Applicant shall record a document holding the City of Solana Beach harmless in case of a sanitary sewer backup due to a blockage in the public sewer main. A backflow prevention device shall be installed on private property.

## V. ENFORCEMENT

Pursuant to SBMC 17.72.120(B) failure to satisfy any and all of the above-mentioned conditions of approval is subject to the imposition of penalties as set forth in SBMC Chapters 1.1.6 and 1.18 in addition to any applicable revocation proceedings.

## VI. EXPIRATION

The Development Review Permit and Structure Development Permit for the

project shall expire 24 months from the date of this Resolution, unless the Applicant have obtained building permits and have commenced construction prior to that date, and diligently pursued construction to completion. An extension of the application may be granted by the City Council according to SBMC 17.72.110.

VII. INDEMNIFICATION AGREEMENT

The Applicant shall defend, indemnify, and hold harmless the City, its agents, officers, and employees from any and all claims, actions, proceedings, damages, judgments, or costs, including attorney’s fees, against the City or its agents, officers, or employees, relating to the issuance of this permit including, but not limited to, any action to attack, set aside, void, challenge, or annul this development approval and any environmental document or decision. The City will promptly notify the Applicant of any claim, action, or proceeding. The City may elect to conduct its own defense, participate in its own defense, or obtain independent legal counsel in defense of any claim related to this indemnification. In the event of such election, the Applicant shall pay all of the costs related thereto, including without limitation reasonable attorney’s fees and costs. In the event of a disagreement between the City and Applicant regarding litigation issues, the City shall have the authority to control the litigation and make litigation related decisions, including, but not limited to, settlement or other disposition of the matter. However, the Applicant shall not be required to pay or perform any settlement unless such settlement is approved by the Applicant.

NOTICE TO APPLICANTS: Pursuant to Government Code Section 66020, you are hereby notified that the 90-day period to protest the imposition of the fees, dedications, reservations or other exactions described in this resolution commences on the effective date of this resolution. To protest the imposition of any fee, dedications, reservations or other exactions described in this resolution you must comply with the provisions of Government Code Section 66020. Generally the resolution is effective upon expiration of the tenth day following the date of adoption of this resolution, unless the resolution is appealed or called for review as provided in the Solana Beach Zoning Ordinance.

**PASSED AND ADOPTED** at a regular meeting of the City Council of the City of Solana Beach, California, held on the 14<sup>th</sup> day of February, 2018, by the following vote:

- AYES: Councilmembers –
- NOES: Councilmembers –
- ABSENT: Councilmembers –
- ABSTAIN: Councilmembers –

---

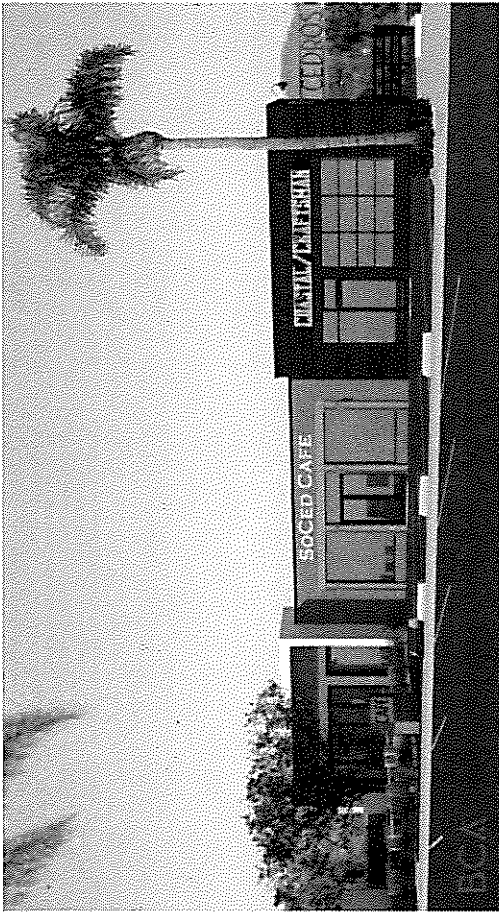
GINGER MARSHALL, Mayor

APPROVED AS TO FORM:

ATTEST:

\_\_\_\_\_  
JOHANNA N. CANLAS, City Attorney

\_\_\_\_\_  
ANGELA IVEY, City Clerk



# USE CHANGE - SUITE 204

BUSINESS OPERATION DESCRIPTION	
Address:	439 South Cedros Avenue, Suite 204
Business Type:	Cafe/Restaurant
Tenant Name:	To be determined
Hours of operation:	9:00 am to 10:00 pm, seven days a week (breakfast, lunch and dinner)
Permitted area:	Interior: 1,271 SF Exterior: 224 SF Total: 1,495 SF
Grease trap required:	Yes
Alcohol sales/Service:	Yes, Beer, Wine and Spirits as part of restaurant operation
Bar service:	No
Alcohol sales (off-site):	No
Amplified music:	No
Live entertainment:	No
Dancing:	No

### AREA SUMMARY

SITE AREA (EXISTING - GROSS)	21,813 SF
DEDICATION AREA @ CEDROS AVE.	2,135 SF
NEW SITE AREA (NET)	19,678 SF
EXISTING IMPROVED	1,500 SF
ACID PROPERTY AT REAR RELEASED	7,800 SF
BUILDING AREA - GROSS	8,127 SF
EXISTING	3,744 SF
NO CHANGE	3,144 SF
SOUTH BUILDINGS	8,987.27 SF
TOTAL	8,987.27 SF
NEW DRIVING AREA (EIGHTHOUSES)	849 SF

### BUILDING AREA BY USE

USE	EXISTING	PROPOSED	TOTAL
RETAIL	3,744 SF	1,500 SF	5,244 SF
OFFICE	3,144 SF	3,144 SF	6,288 SF
CAFE	0 SF	0 SF	0 SF
TOTALS	6,888 SF	4,644 SF	11,532 SF

### PARKING REQUIREMENTS

USE	AREA	RATIO	EXISTING	PROPOSED	TOTAL	
RETAIL	4,403 SF	10:00	16.1	3,112 SF	10:12 SF	9.97
OFFICE	5,504 SF	12:00	18.6	5,504 SF	13:00 SF	16.65
CAFE	0 SF	0	0	0 SF	0 SF	0.00
TOTALS	9,907 SF	11:50	34.7	8,616 SF	10:15 SF	26.62

### PARKING SUMMARY

EXISTING DEMAND FOR CAFE	33
ADDED DEMAND FOR CAFE	11
PROPOSED DEMAND	44
EXISTING PROVIDED	15
REMOVED (EXISTING PROVIDED) + ADDED DEMAND	26
PROPOSED PARKING PROVIDED	26

### HANDICAPPED ACCESSIBLE PARKING

EXISTING	1
PROPOSED	1
TOTAL	2

### FUEL EFFICIENT PARKING\*

EXISTING	0
PROPOSED	1
TOTAL	1

\*SEE THE CALIFORNIA PUBLIC UTILITIES CODE AND THE CALIFORNIA PUBLIC UTILITIES REGULATIONS FOR MORE INFORMATION ON FUEL EFFICIENT PARKING. THE FOLLOWING TABLES ARE REQUIRED TO BE SUBMITTED WITH THE PLANS.

GENERAL NOTES:  
 1. THE BUILDING CANNOT BE OCCUPIED UNTIL THE TENANT IMPROVEMENT HAS BEEN RECEIVED AND APPROVED BY THE BUILDING DEPARTMENT.  
 2. SEE THE CALIFORNIA PUBLIC UTILITIES CODE AND THE CALIFORNIA PUBLIC UTILITIES REGULATIONS FOR MORE INFORMATION ON FUEL EFFICIENT PARKING.  
 3. OCCUPANCY FOR PLACES OF PUBLIC ASSEMBLY OR GROUP GATHERING SHALL BE LIMITED TO THE OCCUPANCY OF THE BUILDING AS SHOWN ON THE PLANS.  
 4. NOTE ON THE PLANS PROVIDE A SIGN ON OR NEAR THE EXIT DOOR READING THIS DOOR TO REMAIN UNLOCKED WHEN THIS SPACE IS OCCUPIED.  
 5. THIS SIGNAGE IS ONLY ALLOWED AT THE MAIN EXIT SECTION 1010.1.3.3.  
 6. HAZARDOUS MATERIALS WILL BE STORED IN ROOMS LISTED IN THE TABLES.  
 7. SEE THE CALIFORNIA PUBLIC UTILITIES CODE AND THE CALIFORNIA PUBLIC UTILITIES REGULATIONS FOR MORE INFORMATION ON FUEL EFFICIENT PARKING.

### PROJECT INFORMATION

PROJECT NAME:	CEDROS COLLECTIVE SUITE 204 USE CHANGE
PROJECT ADDRESS:	439 SOUTH CEDROS AVENUE, SUITE 204, CARLSBAD, CA 92008
PROJECT NUMBER:	2024-001
OWNER:	CECILIA BROWN
ARCHITECT:	BCA ARCHITECTURE

### SCOPE OF WORK

1. PREPARE ARCHITECTURAL PLANS TO ALLOW CONVERSION OF SUITE 204 TO CAFE/TENANT SPACE.  
 2. ALL WORK SHALL BE IN ACCORDANCE WITH THE LATEST EDITIONS OF THE CALIFORNIA BUILDING CODE AND THE CALIFORNIA FIRE CODE.  
 3. ALL CHANGES TO EXISTING CONDITIONS SHALL BE SHOWN ON THE PLANS.  
 4. ALL MATERIALS SHALL BE APPROVED BY THE ARCHITECT AND THE CITY OF SOLANA BEACH.

### CHANGE OF USE SHEET INDEX

NO.	SHEET NAME
UP-1	TITLE SHEET
UP-2	SITE PLAN
UP-3	FLOOR PLAN & ELEVATIONS
UP-4	EGRESS PLAN

### BUILDING CODES

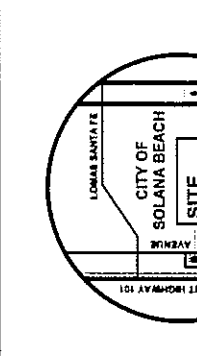
1. THIS PROJECT SHALL COMPLY WITH THE 2018 CALIFORNIA BUILDING CODE, WHICH ADOPTS THE 2018 IBC, 2018 LSC, 2013 UPC AND THE 2018 CALIFORNIA FIRE CODE.  
 2. ALL WORK SHALL BE IN ACCORDANCE WITH THE LATEST EDITIONS OF THE CALIFORNIA BUILDING CODE AND THE CALIFORNIA FIRE CODE.  
 3. ALL CHANGES TO EXISTING CONDITIONS SHALL BE SHOWN ON THE PLANS.  
 4. ALL MATERIALS SHALL BE APPROVED BY THE ARCHITECT AND THE CITY OF SOLANA BEACH.

### GRADING QUANTITIES

REMOVE AND RECOMPACT SOIL - NEW PAVING	12 CY
TERRACING AT LANDSCAPE AREA	4 CY
NEW SOIL AT LANDSCAPING	4 CY
TOTAL	20 CY

### FIRE SPRINKLERS

YES, BUILDING IS SERVED BY AN AUTOMATIC FIRE SPRINKLER SYSTEM



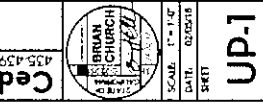
### SUBMITTALS/REVISIONS

NO.	DATE	DESCRIPTION



BCA ARCHITECTURE  
 807 South Cedros Ave  
 Solana Beach, CA 92008  
 (959) 793-3437

Cedros Collective SUITE 204 USE CHANGE  
 TITLE SHEET  
 439 SOUTH CEDROS AVENUE  
 CARLSBAD, CA 92008  
 SCALE: 1" = 1'-0"  
 DATE: 08/20/24  
 SHEET: UP-1



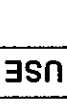
DATE: 05/10/22  
 SCALE: 1" = 10'-0"  
 SHEET: UP-2

**BCA**  
 Brian Church Architects  
 507 South Cedar Ave  
 Solvang, CA 92075  
 (805) 793-3437

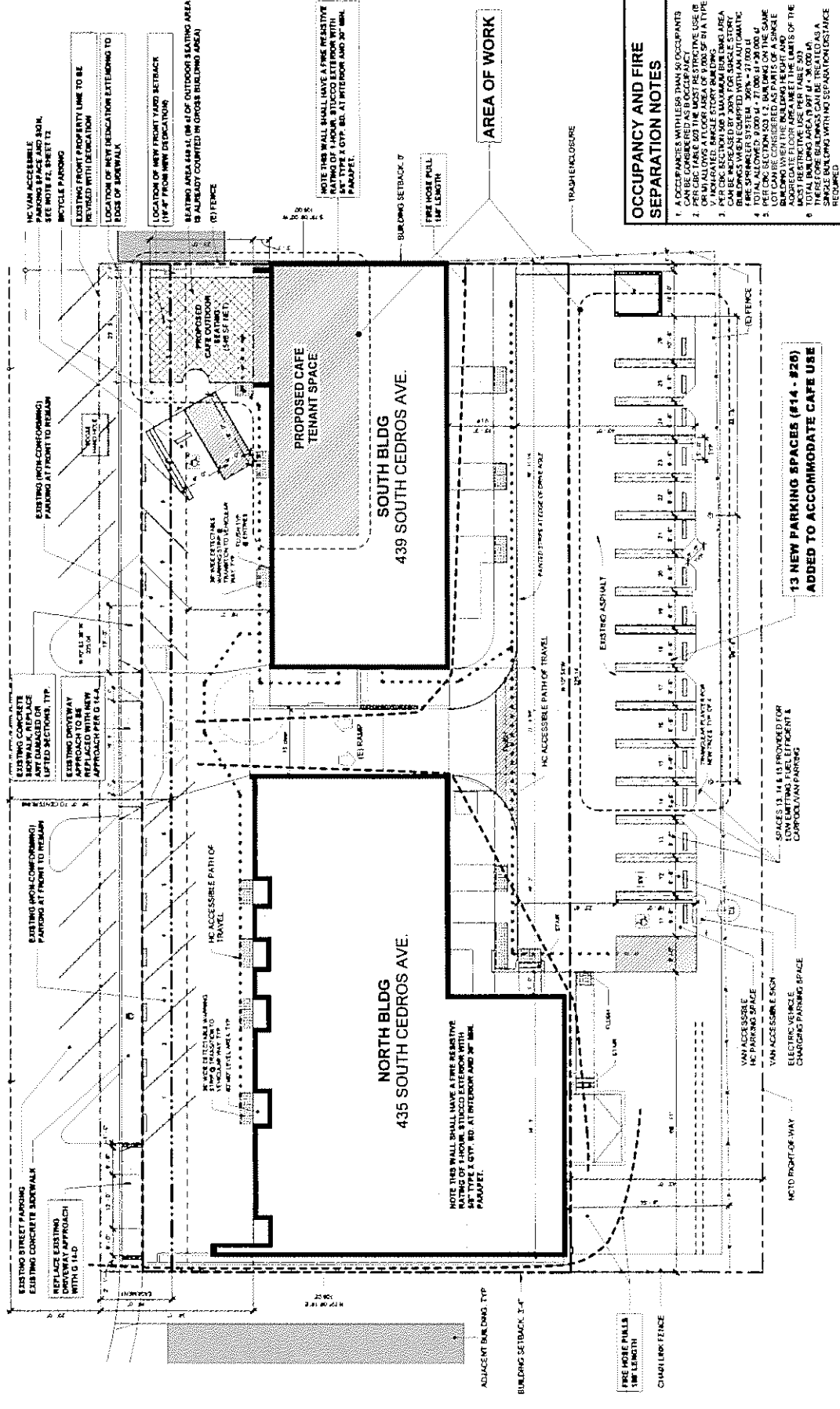
CEDEOS COLLECTIVE SUITE 204 USE CHANGE  
 SITE PLAN

**CEDEOS COLLECTIVE SUITE 204 USE CHANGE**  
 SITE PLAN

DATE: 05/10/22  
 SCALE: 1" = 10'-0"  
 SHEET: UP-2



**SITE PLAN w/ CAFE**  
 1" = 10'-0"



**OCCUPANCY AND FIRE SEPARATION NOTES**

1. OCCUPANCIES WITH LESS THAN 50 OCCUPANTS CAN BE CONSIDERED AS 8 OCCUPANCY.
2. OR (M) ALLOWS A FLOOR AREA OF 7,000 SF BY TYPE.
3. INDICATED SINGLE STORY BUILDING AREA CAN BE INCREASED TO 2,000 SF FOR SINGLE STORY BUILDINGS WHEN EQUIPPED WITH AN AUTOMATIC FIRE SPRINKLER SYSTEM (70K - 17,000 GPM).
4. PREVIOUS SECTION 503 L.I. BAN (MAY) ON THE SAME LOT CAN BE CONSIDERED AS PART OF A SINGLE OCCUPANCY IF THE FLOOR AREA MEETS THE LIMITS OF THE MOST RESTRICTIVE USE PER TABLE 503.
5. THESE FLOOR BUILDINGS CAN BE TREATED AS A SINGLE BUILDING WITH NO SEPARATION DISTANCE REQUIRED.

**13 NEW PARKING SPACES (#14 - #26) ADDED TO ACCOMMODATE CAFE USE**

SPACES 13, 14 & 15 PROVIDED FOR LOW EMITTING FUEL EFFICIENT & CARPOOL/VAN PARKING

VAN ACCESSIBLE SIGN  
 VAN ACCESSIBLE SIGN  
 VAN ACCESSIBLE SIGN

CHARGING PARKING SPACE

EVIC PARKING SPACE

EVIC PARKING SPACE

EVIC PARKING SPACE

EVIC PARKING SPACE

EVIC PARKING SPACE

EVIC PARKING SPACE

EVIC PARKING SPACE

EVIC PARKING SPACE

EVIC PARKING SPACE

EVIC PARKING SPACE

EVIC PARKING SPACE

EVIC PARKING SPACE

EVIC PARKING SPACE

EVIC PARKING SPACE

EVIC PARKING SPACE

EVIC PARKING SPACE

EVIC PARKING SPACE

EVIC PARKING SPACE

EVIC PARKING SPACE

EVIC PARKING SPACE

EVIC PARKING SPACE

EVIC PARKING SPACE

EVIC PARKING SPACE

EVIC PARKING SPACE

EVIC PARKING SPACE

EVIC PARKING SPACE

EVIC PARKING SPACE

EVIC PARKING SPACE

EVIC PARKING SPACE

EVIC PARKING SPACE

EVIC PARKING SPACE

EVIC PARKING SPACE

EVIC PARKING SPACE

EVIC PARKING SPACE

EVIC PARKING SPACE

EVIC PARKING SPACE

EVIC PARKING SPACE

EVIC PARKING SPACE

EVIC PARKING SPACE

EVIC PARKING SPACE

EVIC PARKING SPACE

EVIC PARKING SPACE

EVIC PARKING SPACE

EVIC PARKING SPACE

EVIC PARKING SPACE

EVIC PARKING SPACE

EVIC PARKING SPACE

EVIC PARKING SPACE

EVIC PARKING SPACE

EVIC PARKING SPACE

EVIC PARKING SPACE

EVIC PARKING SPACE

EVIC PARKING SPACE

EVIC PARKING SPACE

EVIC PARKING SPACE

EVIC PARKING SPACE

EVIC PARKING SPACE

EVIC PARKING SPACE

EVIC PARKING SPACE

EVIC PARKING SPACE

EVIC PARKING SPACE

EVIC PARKING SPACE

EVIC PARKING SPACE

EVIC PARKING SPACE

EVIC PARKING SPACE

EVIC PARKING SPACE

EVIC PARKING SPACE

EVIC PARKING SPACE

EVIC PARKING SPACE

EVIC PARKING SPACE

EVIC PARKING SPACE

EVIC PARKING SPACE

EVIC PARKING SPACE

EVIC PARKING SPACE

EVIC PARKING SPACE

EVIC PARKING SPACE

EVIC PARKING SPACE

EVIC PARKING SPACE

EVIC PARKING SPACE

EVIC PARKING SPACE

EVIC PARKING SPACE

EVIC PARKING SPACE

EVIC PARKING SPACE

EVIC PARKING SPACE

EVIC PARKING SPACE

EVIC PARKING SPACE

EVIC PARKING SPACE

EVIC PARKING SPACE

EVIC PARKING SPACE

EVIC PARKING SPACE

EVIC PARKING SPACE

EVIC PARKING SPACE

EVIC PARKING SPACE

EVIC PARKING SPACE

EVIC PARKING SPACE

EVIC PARKING SPACE

EVIC PARKING SPACE

EVIC PARKING SPACE

EVIC PARKING SPACE

EVIC PARKING SPACE

EVIC PARKING SPACE

EVIC PARKING SPACE

EVIC PARKING SPACE

EVIC PARKING SPACE

EVIC PARKING SPACE

EVIC PARKING SPACE

EVIC PARKING SPACE

EVIC PARKING SPACE

EVIC PARKING SPACE

EVIC PARKING SPACE

EVIC PARKING SPACE

EVIC PARKING SPACE

EVIC PARKING SPACE

EVIC PARKING SPACE

EVIC PARKING SPACE

EVIC PARKING SPACE

EVIC PARKING SPACE

EVIC PARKING SPACE

EVIC PARKING SPACE

EVIC PARKING SPACE

EVIC PARKING SPACE

EVIC PARKING SPACE

EVIC PARKING SPACE

EVIC PARKING SPACE

EVIC PARKING SPACE

EVIC PARKING SPACE

EVIC PARKING SPACE

EVIC PARKING SPACE

EVIC PARKING SPACE

EVIC PARKING SPACE

EVIC PARKING SPACE

EVIC PARKING SPACE

EVIC PARKING SPACE

EVIC PARKING SPACE

EVIC PARKING SPACE

EVIC PARKING SPACE

EVIC PARKING SPACE

EVIC PARKING SPACE

EVIC PARKING SPACE

EVIC PARKING SPACE

EVIC PARKING SPACE

EVIC PARKING SPACE

EVIC PARKING SPACE

EVIC PARKING SPACE

EVIC PARKING SPACE

EVIC PARKING SPACE

EVIC PARKING SPACE

EVIC PARKING SPACE

EVIC PARKING SPACE

EVIC PARKING SPACE

EVIC PARKING SPACE

EVIC PARKING SPACE

EVIC PARKING SPACE

EVIC PARKING SPACE

EVIC PARKING SPACE

EVIC PARKING SPACE

EVIC PARKING SPACE

EVIC PARKING SPACE

EVIC PARKING SPACE

EVIC PARKING SPACE

EVIC PARKING SPACE

EVIC PARKING SPACE

EVIC PARKING SPACE

EVIC PARKING SPACE

EVIC PARKING SPACE

EVIC PARKING SPACE

EVIC PARKING SPACE

EVIC PARKING SPACE

EVIC PARKING SPACE

EVIC PARKING SPACE

EVIC PARKING SPACE

EVIC PARKING SPACE

EVIC PARKING SPACE

EVIC PARKING SPACE

EVIC PARKING SPACE

EVIC PARKING SPACE

EVIC PARKING SPACE

EVIC PARKING SPACE

EVIC PARKING SPACE

EVIC PARKING SPACE

EVIC PARKING SPACE

EVIC PARKING SPACE

EVIC PARKING SPACE

EVIC PARKING SPACE

EVIC PARKING SPACE

EVIC PARKING SPACE

EVIC PARKING SPACE

EVIC PARKING SPACE

EVIC PARKING SPACE

EVIC PARKING SPACE

EVIC PARKING SPACE

EVIC PARKING SPACE

EVIC PARKING SPACE

EVIC PARKING SPACE

EVIC PARKING SPACE

EVIC PARKING SPACE

EVIC PARKING SPACE

EVIC PARKING SPACE

EVIC PARKING SPACE

EVIC PARKING SPACE

EVIC PARKING SPACE

EVIC PARKING SPACE

EVIC PARKING SPACE

EVIC PARKING SPACE

EVIC PARKING SPACE

EVIC PARKING SPACE

EVIC PARKING SPACE

EVIC PARKING SPACE

EVIC PARKING SPACE

EVIC PARKING SPACE

EVIC PARKING SPACE

EVIC PARKING SPACE

EVIC PARKING SPACE

EVIC PARKING SPACE

EVIC PARKING SPACE

EVIC PARKING SPACE

EVIC PARKING SPACE

EVIC PARKING SPACE

EVIC PARKING SPACE

EVIC PARKING SPACE

EVIC PARKING SPACE

EVIC PARKING SPACE

EVIC PARKING SPACE

EVIC PARKING SPACE

EVIC PARKING SPACE

EVIC PARKING SPACE

EVIC PARKING SPACE

EVIC PARKING SPACE

EVIC PARKING SPACE

EVIC PARKING SPACE

EVIC PARKING SPACE

EVIC PARKING SPACE

EVIC PARKING SPACE

EVIC PARKING SPACE

EVIC PARKING SPACE

EVIC PARKING SPACE

EVIC PARKING SPACE

EVIC PARKING SPACE

EVIC PARKING SPACE

EVIC PARKING SPACE

EVIC PARKING SPACE

EVIC PARKING SPACE

EVIC PARKING SPACE

EVIC PARKING SPACE

EVIC PARKING SPACE

EVIC PARKING SPACE

EVIC PARKING SPACE

EVIC PARKING SPACE

EVIC PARKING SPACE

EVIC PARKING SPACE

EVIC PARKING SPACE

EVIC PARKING SPACE

EVIC PARKING SPACE

EVIC PARKING SPACE

EVIC PARKING SPACE

EVIC PARKING SPACE











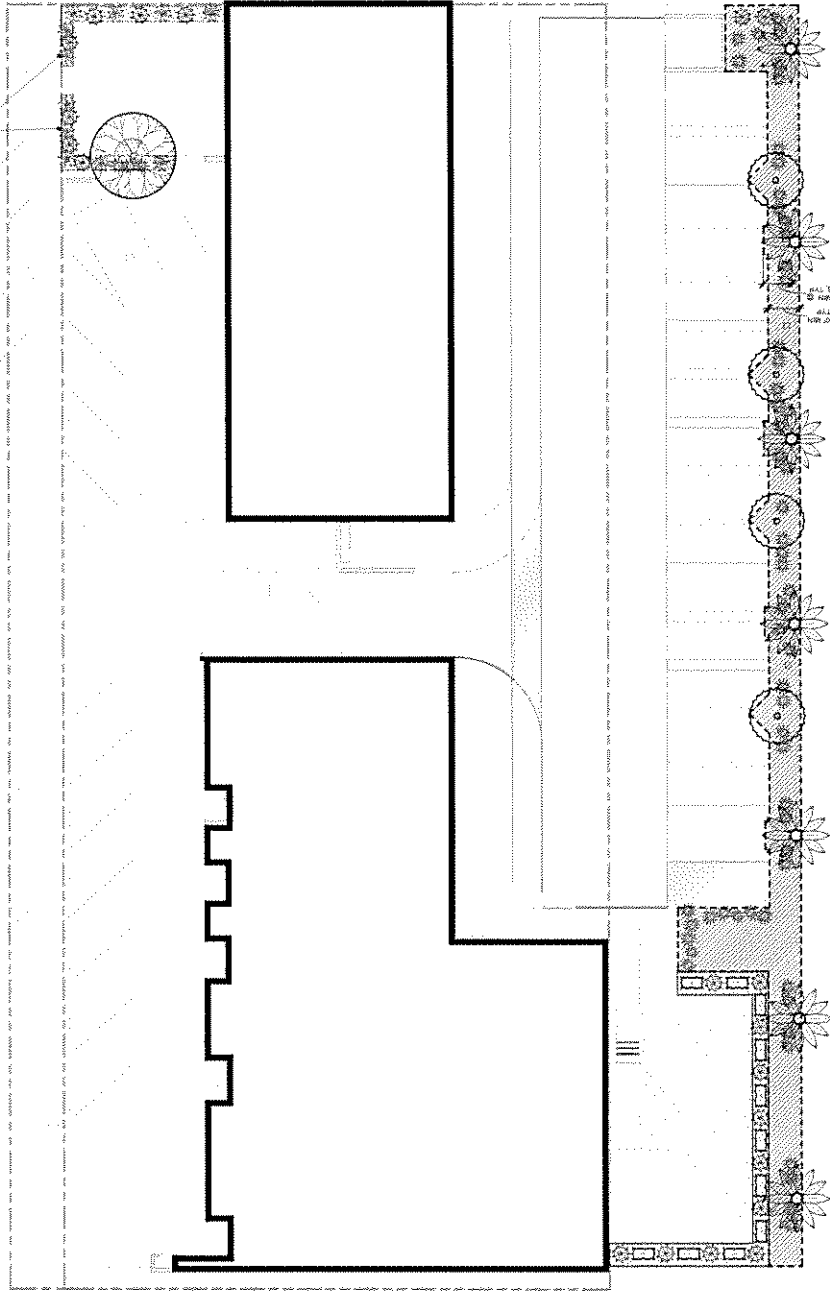


**LANDSCAPE LEGEND**

SYMBOL	COMMON NAME	BOTANICAL NAME	WINDSPEED	#	MATURE SIZE	SIZE	QTY
	CHINESE PISTACHE	POSTACIA CHINENSIS	MODERATE	6	12' - 15'	15 gal	1
	BLUE FAN PALM	BRAHEA DORATA (PARSON)	LOW	3	12' - 15'	5 gal	4
	QUEEN PALM (MATURE EXISTING)	SYAGRUS ROMANZOFFIANA	MODERATE	6	20' - 25'		7
	WESTERN HERBID	CERCIS OCCIDENTALIS N	VERY LOW	1	36"	1 gal	24
	TEXAS RANGER	LEUCOPHYLLUM THURBERGII	LOW	3	36"	1 gal	20

SYMBOL	COMMON NAME	BOTANICAL NAME	WINDSPEED	#	MATURE SIZE	SIZE	QTY
	ROSEMARY	ROSAMARRINUS OFFICINALIS	LOW	3	36"	1 gal	12
	RED FOURBAIN GRASS	PERNASECTUM SETACEUM RUBRIFLUM	LOW	3	36"	1 gal	7
	STONECROP	SEDUM SPECIOSUM AND HYBRIDS	LOW	3	12"	1 gal @ 24" O.C.	66
	TRAILING LANTANA	LANTANA MONTEVEDENSIS	LOW	3	12"	1 gal @ 24" O.C.	100

GROUND COVER



**PLANTING PLAN**

1" = 10'-0"

**STATEMENT/SIGNATURE**

I AM FAMILIAR WITH THE REQUIREMENTS FOR LANDSCAPE AND IRRIGATION PLANS CONTAINED IN THE CITY'S WATER EFFICIENT LANDSCAPE REGULATIONS AND HAVE PREPARED THIS PLAN IN COMPLIANCE WITH THOSE REGULATIONS AND REQUIREMENTS. I AM PROVIDING THIS PLAN TO THE CITY OF BIRMGHAM IN ACCORDANCE WITH THESE REGULATIONS TO PROVIDE AN EFFICIENT USE OF WATER.

*Brian Church*

BRIAN CHURCH AIA

**Cedros Collective**  
435 439 South Cedros Avenue  
Sedona Beach, CA 92075

PLANTING PLAN



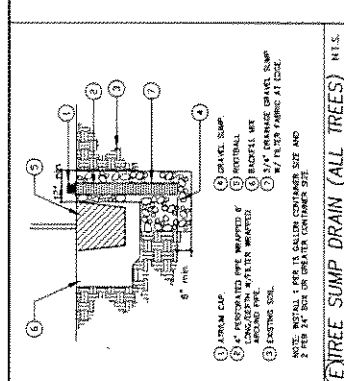
DATE: 02/02/18  
SHEET

**L2**

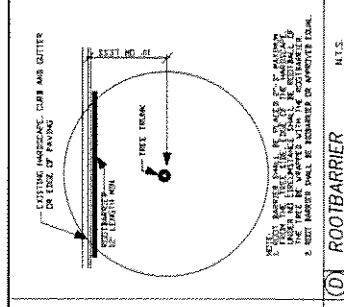
**BCA**

Brian Church Architecture  
307 South Cedros Ave  
Sedona Beach, CA 92075  
(958) 793-3437

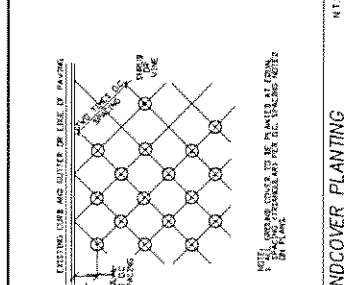
STATEMENTS/REVISIONS



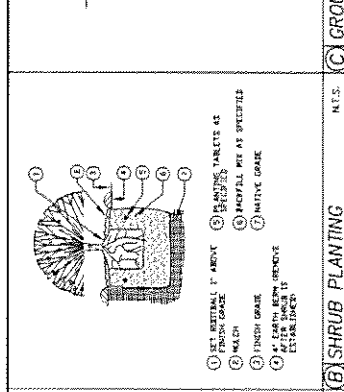
**(A) TREE SUMP DRAIN (ALL TREES)** N.T.S.



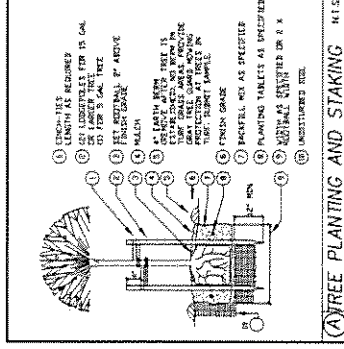
**(B) ROOT BARRIER** N.T.S.



**(C) GROUNDCOVER PLANTING** N.T.S.



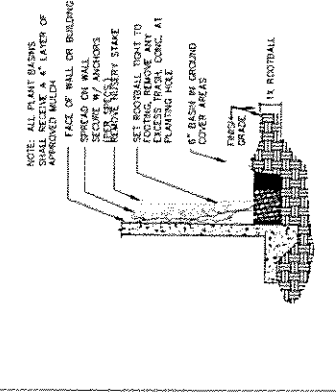
**(D) SHRUB PLANTING** N.T.S.



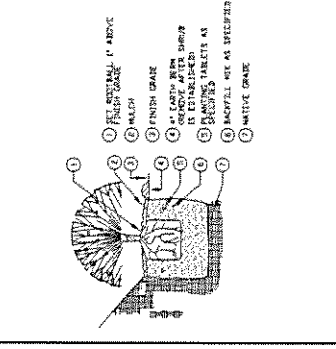
**(E) TREE PLANTING AND STAKING** N.T.S.

**PLANTING NOTES:**

1. CONTRACTOR SHALL HAVE A SOIL SAMPLE ANALYSIS COMPLETED BY A LICENSED AGRICULTURAL LABORATORY PRIOR TO AND AFTER LEADINGS OF SALTS AND BRUSH TO ANY PLANTING OF PLANT MATERIAL. PROVIDE A LIST OF THE PROPOSED PLANT MATERIAL TO AGRICULTURIST FOR ANALYSIS AND RECOMMENDATIONS TO BE SUBMITTED TO THE LANDSCAPE ARCHITECT.
2. ALL PLANT MATERIAL SHALL BE APPROVED AT THE PROJECT SITE BY THE OWNER'S REPRESENTATIVE PRIOR TO ANY PLANTING. ALL PLANT MATERIAL REJECTED BY THE OWNER'S REPRESENTATIVE SHALL BE REMOVED FROM THE PROJECT SITE IMMEDIATELY.
3. ALL PLACEMENT OF PLANT MATERIAL SHALL BE APPROVED BY THE OWNER'S REPRESENTATIVE PRIOR TO PLANTING.
4. ALL PLANT SIZES ARE MINIMUMS. SIZES ARE TYPICAL FOR EACH PLANT SPECIES. ALL PLANTS ARE TO BE FREE OF DISEASE AND SCARS, AND ARE HAVE GOOD COLOR, FULL HEADS AND GOOD CALIPER (15 GALLON - 3/4" MINIMUM, 24" BOX - 1 1/4" MINIMUM, 36" BOX - 2" MINIMUM).
5. ALL PLANTS SHALL BE FULLY ROOTED AND READY FOR PLANTING. PLANTS SHALL BE FULLY OPERATIONAL AND ALL PLANTING AREAS SHALL BE FREE OF WEEDS, ROCKS AND DEBRIS. RAKE AND FINE GRADE ALL PLANTING AREAS PRIOR TO PLANTING.
6. UPON COMPLETION OF PLANTING OPERATIONS AND BEFORE ANY SITE OBSERVATIONS, REMOVE ALL EXTERNAL CURBS, WALKS, AND DEBRIS, AND BRUSH AND WASH THE AREA CLEAN.
7. ALL PLANTING OPERATIONS SHALL BE INSTALLED PER THE COUNTY OF SAN DIEGO LANDSCAPE ORDINANCE.
8. CONTRACTOR SHALL PROTECT IN PLACE ALL EXISTING PLANT MATERIAL UNLESS OTHERWISE NOTED. ANY EXISTING PLANT MATERIAL OR IRRIGATION SYSTEMS DAMAGED AS PART OF OR DUE TO CONSTRUCTION SHALL BE REPAIRED OR REPLACED AT THE CONTRACTOR'S EXPENSE.
9. CONTRACTOR SHALL BE RESPONSIBLE FOR SUPPLYING ALL PLANT MATERIAL AS SHOWN BY SYMBOLS SHOWN ON PLANS. THE SPECIFICATIONS FOR SUPPLYING ALL PLANT MATERIAL, UNLESS OTHERWISE STATED WITHIN THESE BID ADDENDUMS.
10. BARK MULCH SHALL BE KEPT A MIN. OF 12" FROM THE BUILDING STRUCTURE. ALL OTHER AREAS ARE TO RECEIVE A MINIMUM 3" THICK BARK MULCH.



**(F) VINE ON WALL OR BUILDING** N.T.S.



**(G) SHRUB PLANTING ON SLOPE** N.T.S.

### IRRIGATION SCHEDULE - BASED ON ETO FOR TORREY PINES, SOURCE CIMIS

SCHEDULE IS APPROXIMATE ONLY. ACTUAL SCHEDULE MUST BE DETERMINED BY A QUALIFIED IRRIGATION PROFESSIONAL AND WILL DEPEND ON FACTORS SUCH AS TIME OF YEAR, WEATHER, RAINFALL AND PERCOLATION RATES. DRIP SYSTEMS SHOULD BE OPERATED FOR APPROXIMATELY 15 MINUTES PER CYCLE. DURING ESTABLISHMENT, IRRIGATION MAY BE INCREASED AS FREQUENT AS EVERY DAY, BUT SHALL BE REDUCED TO THE FOLLOWING AFTER 90 DAYS. DURING HOT WEATHER, IRRIGATION SHOULD BE APPROX. TWICE PER WEEK DURING COOLER SEASONS. ONE CYCLE PER WEEK MAY BE ADEQUATE. IF RUN OFF OCCURS, BREAK DOWN IRRIGATION INTO SHORTER DURATIONS WITH A FEW MORE CYCLES BETWEEN EACH CYCLE AND SOON. NO IRRIGATION SHOULD BE REQUIRED WHEN ADEQUATE RAINFALL HAS OCCURRED. THIS PLAN IS BASED ON THE CURRENT IRRIGATION SCHEDULE POLICIES AND PROCEDURES OF THE SAN JUAN IRRIGATION DISTRICT.

**PRECIPITATION INTERCEPTION PRESUMED**  
 12" SPACING OF EMITTERS AND BUBBLERS  
 1.45 INCHES PER HOUR  
 RUN TIMES SHALL BE CONSISTENT WITH THE APPROVED ETWM AND CURRENT SAN JUAN IRRIGATION DISTRICT REGULATIONS.

WATERING SCHEDULE	
SEASONS	CYCLES PER WEEK
SPRING	2-3
FALL	1-2
WINTER	0-1
SUMMER	1-2

### IRRIGATION NOTES

1. IRRIGATION SHALL BE SUB MITERED.
2. RAIN SENSORS EITHER INTEGRAL OR AUXILIARY, SHALL BE INSTALLED ON ALL IRRIGATION SYSTEMS.
3. FLOW SENSORS SHALL BE INSTALLED ON ALL MAINS AND BRANCH SYSTEMS. FLOW SENSORS SHALL BE INSTALLED WITHIN A MASTER VALVE SUIT OF DIRECTION OR IRRIGATION SHARED AREAS LESS THAN 10 FEET IN WIDTH IN ANY DIRECTION. SHALL BE INSTALLED WITH SURFACE IRRIGATION.
4. LOW HEAD DRAINAGE AND OTHER SIMILAR CONDITIONS WHERE IRRIGATION WATER FLOWS OR SPILLS INTO AREAS NOT INTENDED FOR IRRIGATION SHALL BE INSTALLED AT ADEQUATE AREA DRAINAGE OR ROADWAY. SHALL BE INSTALLED INSIDE A PVC CONDUIT.
5. SPRINKLER HEADS AND IRRIGATION DEVICES THAT DELIVER WATER, SUCH AS SPRINKLER HEADS, SHALL BE INSTALLED AT A MINIMUM OF 12 INCHES WITHIN 24 INCHES OF A VEHICLE OR PEDESTRIAN USE AREA. THE DIRECTOR MAY ALLOW ON GRADE PIPING WHERE LANDFORM CONSTRAINTS MAKE BELOW GRADE PIPING.
6. THE IRRIGATION SYSTEM SHALL PROVIDE FOR THE INSTALLATION OF A MANUAL SHUTOFF VALVE AS CLOSE AS POSSIBLE TO THE WATER SUPPLY ADDITIONAL TO THE IRRIGATION SYSTEM AND THE WATER SUPPLY.
7. THE IRRIGATION SYSTEM SHALL BE INSTALLED TO BE OPEN IN EACH ZONE OF THE IRRIGATION SYSTEM AND THE WATER SUPPLY.
8. ALL AREAS ARE SUBJECT TO THE CITY'S LANDSCAPE AND REGULATIONS GOVERNING OR MADE PART OF THESE SPECIFICATIONS AND THEIR PROVISIONS SHALL BE RELATION TO ANY PORTION OF THIS WORK ARE HEREBY INCORPORATED INTO AND MADE PART OF THESE SPECIFICATIONS AND THEIR PROVISIONS SHALL BE:
9. THE CONTRACTOR SHALL VERIFY THE LOCATIONS OF ALL EXISTING UTILITIES, STRUCTURES AND SERVICES BEFORE COMMENCING WORK. THE LOCATIONS OF UTILITIES SHALL BE VERIFIED BY THE CONTRACTOR AND APPROXIMATE ONLY. ANY DISCREPANCIES BETWEEN THESE PLANS AND ACTUAL FIELD CONDITIONS SHALL BE REPORTED TO THE OWNER REPRESENTATIVE.
10. ALL UTILITIES SHALL BE IDENTIFIED BY THE CONTRACTOR'S ENGINEERING OR ARCHITECTURAL PLANS BEFORE BEGINNING WORK.
11. THE CONTRACTOR SHALL OBTAIN ALL NECESSARY PERMITS REQUIRED TO PERFORM THE WORK INDICATED HEREIN BEFORE BEGINNING WORK, AS SHOWN ON THE PLANS. THE CONTRACTOR SHALL BE RESPONSIBLE FOR OBTAINING ALL NECESSARY PERMITS AND FOR THE TIME AND COST OF OBTAINING SUCH PERMITS. ANY SUCH REPRESENTATIVE PRIOR TO ANY WORK OR THE IRRIGATION CONTRACTOR SHALL ASSUME ALL RESPONSIBILITY FOR ANY FIELD CHANGES DEEMED NECESSARY BY THE CONTRACTOR.
12. ALL MATERIALS AND EQUIPMENT AS SHOWN IN THE DETAILS AND SPECIFICATIONS SHALL BE INSTALLED AND THE CONTRACTOR SHALL BE RESPONSIBLE TO COMPLY WITH LOCAL CITY, COUNTY AND STATE REQUIREMENTS FOR BOTH EQUIPMENT AND INSTALLATION.

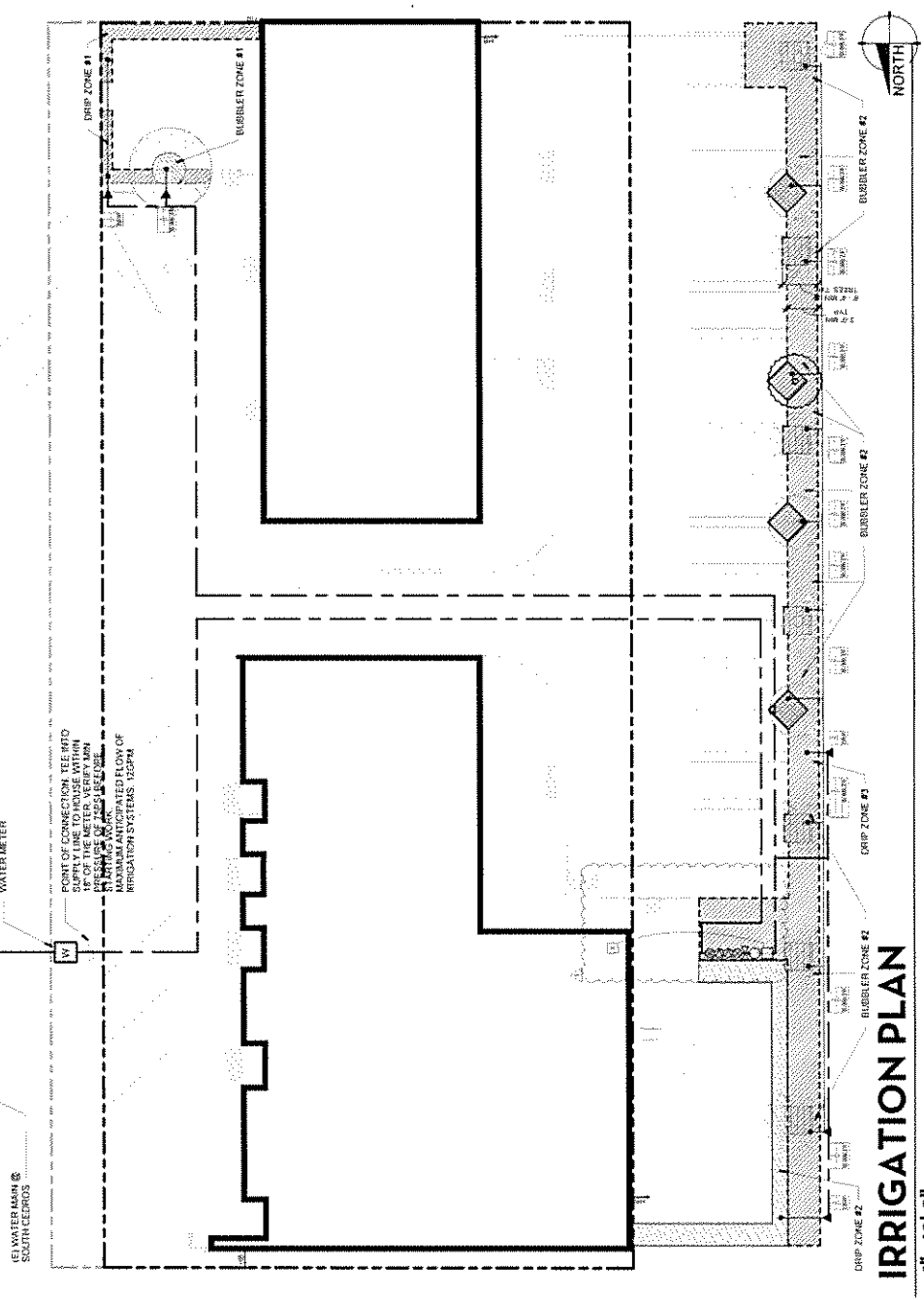
### STATEMENT/SIGNATURE

I AM FAMILIAR WITH THE REQUIREMENTS FOR LANDSCAPE AND IRRIGATION AND I HAVE PREPARED THIS PLAN IN COMPLIANCE WITH THOSE REGULATIONS AND THOSE REGULATIONS TO PROVIDE AN EFFICIENT USE OF WATER.

*Brian Church*  
 BRIAN CHURCH, AIA

SYMBOL	MANUFACTURER	MODEL	DESCRIPTION
○	CHAMPION	2 1/2" SIZE BRASS	HOSE DRR, DOWNWARD POINTING
▽	RAINBIRD	ACV-100 PFR-BF	1" DRIP ZONE CONTROL VALVE FILTER REGULATOR WITH 1/2" NPT IN GARDEN REEL AND GARDEN REEL VALVE BOX. PROVIDE DRIP SYSTEM PER DETAIL.
⊗	FERCO	63K - 1" SIZE 500 YDSR	REDUCED PRESSURE BACKFLOW PREVENTER WITH PRESSURE REGULATOR AND Y-STRAINER. SPRING RANGE 25-75 PSI
⊕	RAINBIRD	3 IN 300 EPDS MASTER VALVE	3 IN 300 EPDS MASTER VALVE
○	RAINBIRD	1 1/2 IN BRASS FLOW SENSOR	BRASS FLOW SENSOR FOR FLOW AND ACCURATE FLOW MONITORING
□	WEATHERMATIC	MODEL SL 600	IRRIGATION CONTROLLER - 18 ZONE
⊞	WEATHERMATIC	MODEL SLW70	ON-SITE COMMERCIAL WEATHER STATION. MOUNT TO HOOD AND CONNECT TO CONTROLLER WITH WIRES IN ELECTRICAL CONDUIT

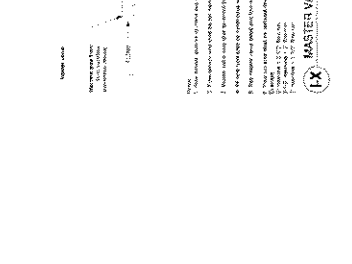
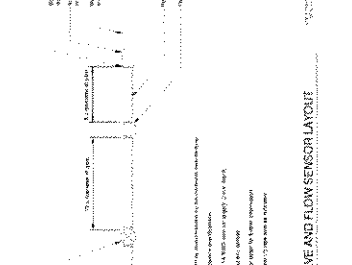
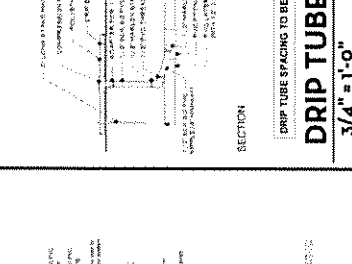
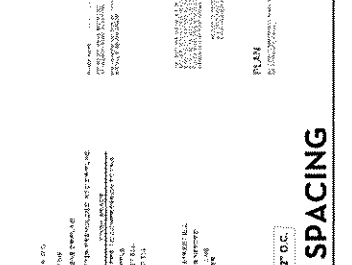
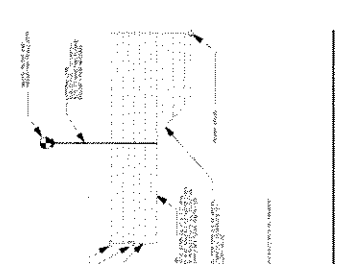
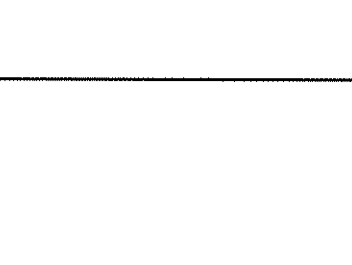
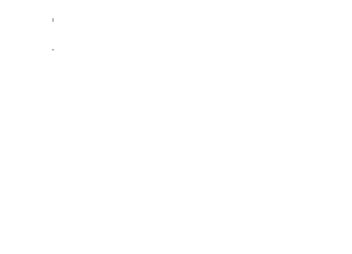
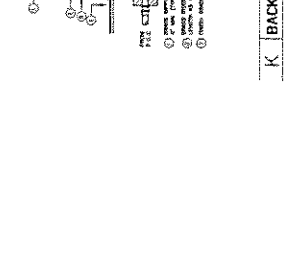
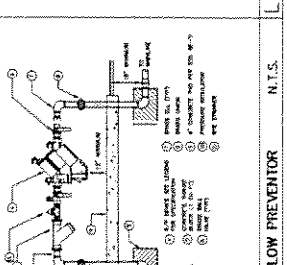
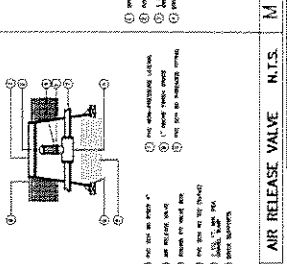
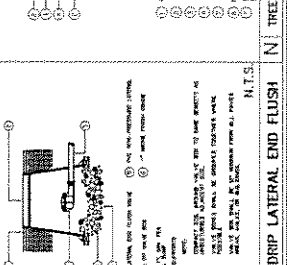
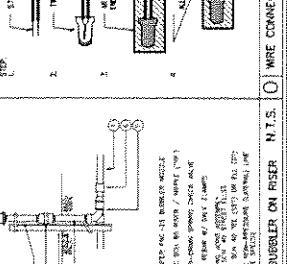
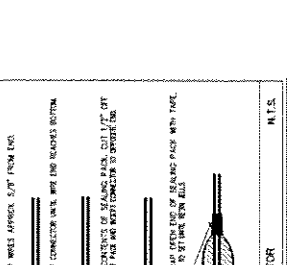
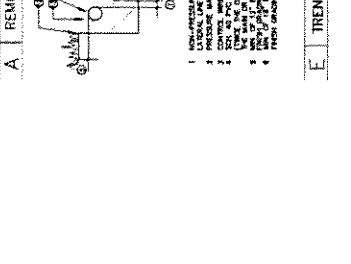
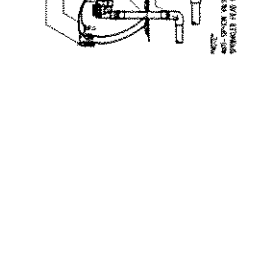
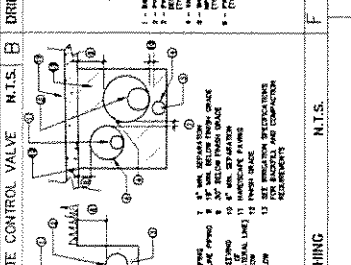
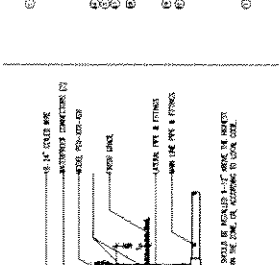
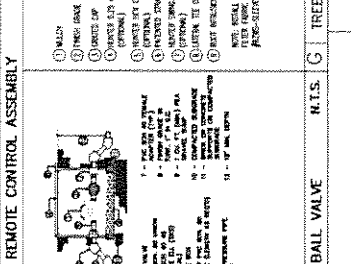
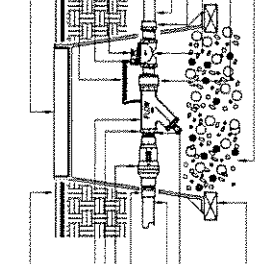
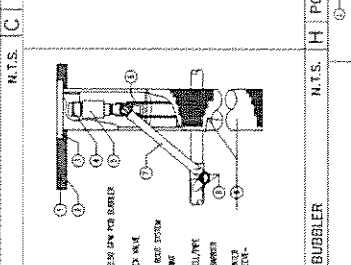
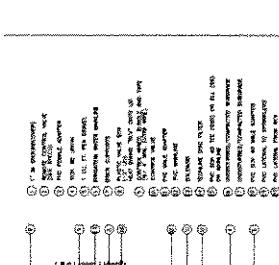
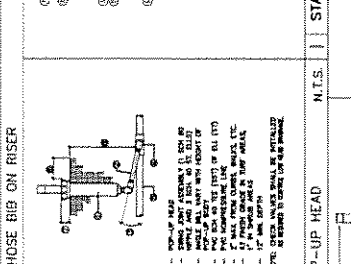
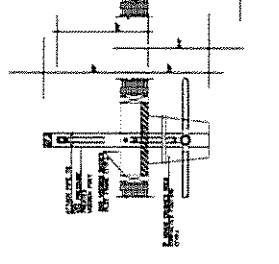
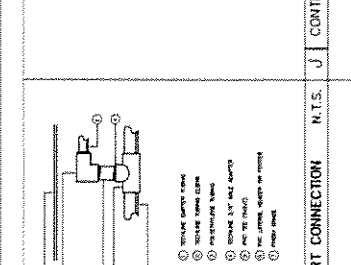
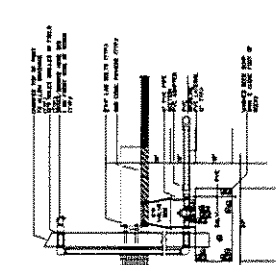
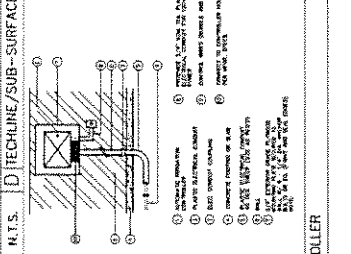
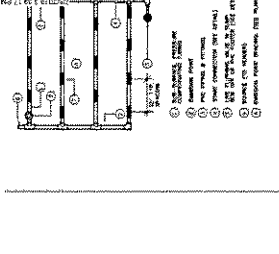
TYPE OR COMPONENT		AMOUNT	UNIT	PRICE	TOTAL
1" DRIP ZONE CONTROL VALVE FILTER REGULATOR WITH 1/2" NPT IN GARDEN REEL AND GARDEN REEL VALVE BOX. PROVIDE DRIP SYSTEM PER DETAIL.	1	1	1	1	1
REDUCED PRESSURE BACKFLOW PREVENTER WITH PRESSURE REGULATOR AND Y-STRAINER. SPRING RANGE 25-75 PSI	1	1	1	1	1
3 IN 300 EPDS MASTER VALVE	1	1	1	1	1
BRASS FLOW SENSOR FOR FLOW AND ACCURATE FLOW MONITORING	1	1	1	1	1
IRRIGATION CONTROLLER - 18 ZONE	1	1	1	1	1
ON-SITE COMMERCIAL WEATHER STATION. MOUNT TO HOOD AND CONNECT TO CONTROLLER WITH WIRES IN ELECTRICAL CONDUIT	1	1	1	1	1
<b>TOTAL</b>	<b>5</b>	<b>5</b>	<b>5</b>	<b>5</b>	<b>5</b>



### IRRIGATION PLAN

1" = 10'-0"





**DRIP TUBE SPACING**  
 3/4" = 1'-0"

**SECTION**

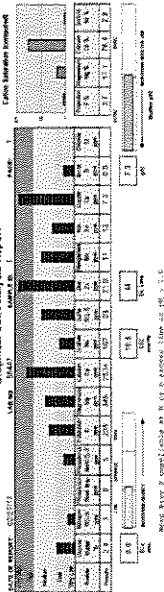
**PLAN**

DRIP TUBE SPACING TO BE 17" O.C.

1. 1/2" DIA. PVC PIPE  
 2. 1/2" DIA. PVC PIPE  
 3. 1/2" DIA. PVC PIPE  
 4. 1/2" DIA. PVC PIPE  
 5. 1/2" DIA. PVC PIPE  
 6. 1/2" DIA. PVC PIPE  
 7. 1/2" DIA. PVC PIPE  
 8. 1/2" DIA. PVC PIPE  
 9. 1/2" DIA. PVC PIPE  
 10. 1/2" DIA. PVC PIPE  
 11. 1/2" DIA. PVC PIPE  
 12. 1/2" DIA. PVC PIPE  
 13. 1/2" DIA. PVC PIPE  
 14. 1/2" DIA. PVC PIPE  
 15. 1/2" DIA. PVC PIPE  
 16. 1/2" DIA. PVC PIPE  
 17. 1/2" DIA. PVC PIPE  
 18. 1/2" DIA. PVC PIPE  
 19. 1/2" DIA. PVC PIPE  
 20. 1/2" DIA. PVC PIPE  
 21. 1/2" DIA. PVC PIPE  
 22. 1/2" DIA. PVC PIPE  
 23. 1/2" DIA. PVC PIPE  
 24. 1/2" DIA. PVC PIPE  
 25. 1/2" DIA. PVC PIPE  
 26. 1/2" DIA. PVC PIPE  
 27. 1/2" DIA. PVC PIPE  
 28. 1/2" DIA. PVC PIPE  
 29. 1/2" DIA. PVC PIPE  
 30. 1/2" DIA. PVC PIPE  
 31. 1/2" DIA. PVC PIPE  
 32. 1/2" DIA. PVC PIPE  
 33. 1/2" DIA. PVC PIPE  
 34. 1/2" DIA. PVC PIPE  
 35. 1/2" DIA. PVC PIPE  
 36. 1/2" DIA. PVC PIPE  
 37. 1/2" DIA. PVC PIPE  
 38. 1/2" DIA. PVC PIPE  
 39. 1/2" DIA. PVC PIPE  
 40. 1/2" DIA. PVC PIPE  
 41. 1/2" DIA. PVC PIPE  
 42. 1/2" DIA. PVC PIPE  
 43. 1/2" DIA. PVC PIPE  
 44. 1/2" DIA. PVC PIPE  
 45. 1/2" DIA. PVC PIPE  
 46. 1/2" DIA. PVC PIPE  
 47. 1/2" DIA. PVC PIPE  
 48. 1/2" DIA. PVC PIPE  
 49. 1/2" DIA. PVC PIPE  
 50. 1/2" DIA. PVC PIPE  
 51. 1/2" DIA. PVC PIPE  
 52. 1/2" DIA. PVC PIPE  
 53. 1/2" DIA. PVC PIPE  
 54. 1/2" DIA. PVC PIPE  
 55. 1/2" DIA. PVC PIPE  
 56. 1/2" DIA. PVC PIPE  
 57. 1/2" DIA. PVC PIPE  
 58. 1/2" DIA. PVC PIPE  
 59. 1/2" DIA. PVC PIPE  
 60. 1/2" DIA. PVC PIPE  
 61. 1/2" DIA. PVC PIPE  
 62. 1/2" DIA. PVC PIPE  
 63. 1/2" DIA. PVC PIPE  
 64. 1/2" DIA. PVC PIPE  
 65. 1/2" DIA. PVC PIPE  
 66. 1/2" DIA. PVC PIPE  
 67. 1/2" DIA. PVC PIPE  
 68. 1/2" DIA. PVC PIPE  
 69. 1/2" DIA. PVC PIPE  
 70. 1/2" DIA. PVC PIPE  
 71. 1/2" DIA. PVC PIPE  
 72. 1/2" DIA. PVC PIPE  
 73. 1/2" DIA. PVC PIPE  
 74. 1/2" DIA. PVC PIPE  
 75. 1/2" DIA. PVC PIPE  
 76. 1/2" DIA. PVC PIPE  
 77. 1/2" DIA. PVC PIPE  
 78. 1/2" DIA. PVC PIPE  
 79. 1/2" DIA. PVC PIPE  
 80. 1/2" DIA. PVC PIPE  
 81. 1/2" DIA. PVC PIPE  
 82. 1/2" DIA. PVC PIPE  
 83. 1/2" DIA. PVC PIPE  
 84. 1/2" DIA. PVC PIPE  
 85. 1/2" DIA. PVC PIPE  
 86. 1/2" DIA. PVC PIPE  
 87. 1/2" DIA. PVC PIPE  
 88. 1/2" DIA. PVC PIPE  
 89. 1/2" DIA. PVC PIPE  
 90. 1/2" DIA. PVC PIPE  
 91. 1/2" DIA. PVC PIPE  
 92. 1/2" DIA. PVC PIPE  
 93. 1/2" DIA. PVC PIPE  
 94. 1/2" DIA. PVC PIPE  
 95. 1/2" DIA. PVC PIPE  
 96. 1/2" DIA. PVC PIPE  
 97. 1/2" DIA. PVC PIPE  
 98. 1/2" DIA. PVC PIPE  
 99. 1/2" DIA. PVC PIPE  
 100. 1/2" DIA. PVC PIPE



CLIENT: 1506  
 GENUS: CEDROS COLLECTIVE  
 PROJECT: GEOTECHNICAL SOILS REPORT



**Soil Fertility Guidelines**

NOTE: Bulk Density (BD) is the ratio of soil mass to soil volume. It is a key indicator of soil compaction and porosity. High bulk density indicates compacted soil, which can restrict root growth and water infiltration.

Moisture (M) is the amount of water held in the soil. It is essential for plant growth and nutrient uptake. Low moisture levels can indicate drought stress or poor soil structure.

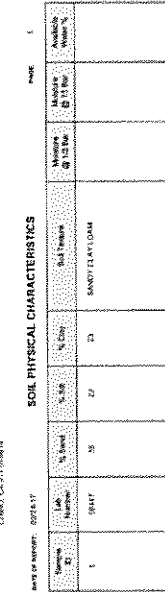
Organic Matter (OM) is the decomposed plant and animal material in the soil. It improves soil structure, water retention, and provides a source of nutrients for soil microorganisms.

Nitrogen (N) is a primary nutrient for plant growth. It is essential for the synthesis of proteins and nucleic acids. Low nitrogen levels can result in stunted growth and yellowing of leaves.

Phosphorus (P) is a secondary nutrient that plays a role in energy transfer and root development. Low phosphorus levels can result in poor root growth and delayed maturity.

Potassium (K) is a secondary nutrient that is important for overall plant health and disease resistance. Low potassium levels can result in weak stems and increased susceptibility to frost damage.

CLIENT: 1205  
 GENUS: CEDROS COLLECTIVE  
 PROJECT: SOILS ANALYSIS



**SOIL PHYSICAL CHARACTERISTICS**

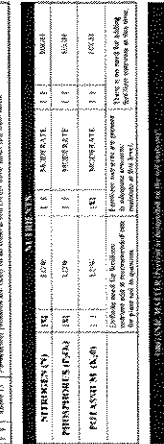
SOIL TYPE: SANDY SILT CLAY

Soil Physical Characteristics Summary:

- Bulk Density: 1.50 g/cm<sup>3</sup>
- Moisture: 12.5%
- Organic Matter: 0.5%
- Soil Temperature: 15.0°C

Soil physical characteristics are crucial for understanding soil behavior and plant growth. Bulk density affects soil porosity and water infiltration. Moisture content is a key indicator of soil water availability. Organic matter improves soil structure and nutrient retention. Soil temperature affects microbial activity and nutrient cycling.

CLIENT: 5447  
 GENUS: CEDROS COLLECTIVE  
 PROJECT: SOILS ANALYSIS



**NUTRIENT ANALYSIS**

Nutrient Analysis Summary:

- Nitrogen (N): 0.15%
- Phosphorus (P): 0.05%
- Potassium (K): 0.20%
- Calcium (Ca): 0.10%
- Magnesium (Mg): 0.05%

Nutrient levels are essential for plant growth and development. Nitrogen is a primary nutrient for protein synthesis. Phosphorus is important for energy transfer and root growth. Potassium is a secondary nutrient that improves overall plant health. Calcium and magnesium are secondary nutrients that play roles in cell wall structure and enzyme activity.

**INTERPRETATION OF ANALYSIS**

Soil nutrient levels are compared to established standards for plant growth. The analysis shows that the soil has low levels of nitrogen and phosphorus, which may limit plant growth. Potassium levels are within the recommended range. Calcium and magnesium levels are also within the recommended range.

Soil nutrient levels are a key indicator of soil fertility. Low nutrient levels can result in stunted growth and poor crop yields. High nutrient levels can result in excessive vegetative growth and increased susceptibility to disease. Maintaining balanced nutrient levels is essential for optimal plant growth.

**SOIL MANAGEMENT REPORT**

**EXISTING SOILS (PER GEOTECHNICAL SOILS REPORT)**

UPPER LAYER OF EXISTING SOILS IS 0-2 FT. CONSISTS OF UNDIFFERENTIATED SANDY FILL WITH MODERATE TO HIGH PLASTICITY. LOWER LAYER IS A FINE GRAINED SANDY SILT CLAY WITH MODERATE TO HIGH PLASTICITY. THE SOILS ARE CLASSIFIED AS SM AND SC. THE SOILS ARE WEAKLY TO MODERATELY COMPRESSED. THE SOILS ARE WEAKLY TO MODERATELY COMPRESSED. THE SOILS ARE WEAKLY TO MODERATELY COMPRESSED.

**SOILS TREATMENT**

ALL REPAIRS OCCURRING IN EXISTING LANDSCAPE/PLANTING AREAS SHALL REQUIRE MINIMAL SOIL AMENDMENTS (4% ORGANIC MATTER). AN AMMENDMENT OF 2% ORGANIC MATTER SHALL BE APPLIED TO ALL AREAS OF SOILS THAT ARE WEAKLY TO MODERATELY COMPRESSED. THE SOILS ARE WEAKLY TO MODERATELY COMPRESSED. THE SOILS ARE WEAKLY TO MODERATELY COMPRESSED.

**EVALUATION OF SOIL ELEMENTS:**

1. THIS Slightly elevated, indicating early alkaline soil. GROUNDWATER SOIL SALINITY AND LEACHING WILL HELP TO LOWER LEVELS OVER TIME.

2. SOIL SALINITY AND LEACHING WILL HELP TO LOWER LEVELS OVER TIME. SOIL SALINITY AND LEACHING WILL HELP TO LOWER LEVELS OVER TIME. SOIL SALINITY AND LEACHING WILL HELP TO LOWER LEVELS OVER TIME.

**SPECIAL COMMENTS:**

1. SELECTIVE PLANT PALETTE IMPORTANT. BE ELEVATED LIME. AMENDMENTS ARE MORE EFFECTIVE WHEN THOROUGHLY MIXED INTO THE SOIL.

2. MAJOR NUTRIENTS: NITROGEN IS LOW. PHOSPHORUS IS LOW. POTASSIUM IS MODERATE. GROUNDWATER PRODUCTS USED AT SPECIFIED RATES WILL ESTABLISH AND MAINTAIN SOIL SALINITY AND LEACHING WILL HELP TO LOWER LEVELS OVER TIME.

**SOIL PREPARATION:**

MATERIALS RECOMMENDED PER 1,000 SQUARE FEET:

- 10 LBS. SOIL SALINITY
- 30 LBS. GROUNDWATER PLUS
- 3 CU. YD. OF RETICULATED SHAKINGS OR GOOD QUALITY COMPOST

**MAINTENANCE:**

INITIALLY FEED WITH 20 LBS. GROUNDWATER PLUS PER 1,000 SQ. FT. ON DAY 45 AND WEEKS 10, 20, 30, 40, 50, 60, 70, 80, 90, 100, 110, 120, 130, 140, 150, 160, 170, 180, 190, 200. MAINTENANCE SCHEDULE FOR MORE SPECIFIC RECOMMENDATIONS.

## South Cedros Associates, LLC

January 24, 2018

City Council  
City of Solana Beach, CA.

Re: Proposed Café at 435-437 S. Cedros

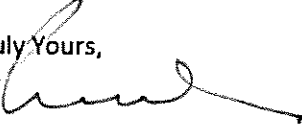
Dear City Council Members,

This note will confirm my support of the proposed cafe to be located on South Cedros Avenue.

As a Member of the South Cedros Property Owners' Association, I can confirm that the SCPOA supports this category of use for the Cedros Avenue Design District. This use in this location can be expected to add a much-needed gathering place for the South Cedros Design District customers and Cedros community members.

I encourage the City Council to support the Café use.

Very Truly Yours,



Sean MacLeod  
South Cedros Associates, LLC



# STAFF REPORT CITY OF SOLANA BEACH

**TO:** Honorable Mayor and City Councilmembers  
**FROM:** Gregory Wade, City Manager  
**MEETING DATE:** February 14, 2018  
**ORIGINATING DEPT:** Community Development Department  
**SUBJECT:** **Public Hearing: DRP for 601 W. Circle Drive  
(Case # 17-17-13 Applicants: Scott and Lisa Harris  
Resolution No. 2018-013)**

---

## BACKGROUND

The Applicants, Scott and Lisa Harris, are seeking the Council's approval of a Development Review Permit (DRP) to remodel an existing single-story, single family residence with an attached garage located at 601 W. Circle Drive. The existing residence was constructed in 1951 prior to the City's incorporation and prior to the adoption of the Zoning Ordinance and the Local Coastal Program Land Use Plan which require a minimum 40 foot rear yard setback from the top edge of the coastal bluff.

The existing home consists of 1,544 square feet of living area and an attached 281 square foot garage. The Applicants are requesting the approval of a DRP in order to convert the existing garage to living space, add a covered patio in front of the proposed residence, remodel the interior of the existing residence and associated site improvements. The patio cover is proposed at 13.83 feet above the existing grade. The 5,726 square foot lot is located within the Medium Residential (MR) Zone and the Scaled Residential Overlay Zone (SROZ). The proposed project is below the bluff top redevelopment project threshold(s) as defined by the City's Certified Local Coastal Program (LCP) Land Use Plan (LUP) as discussed in this Staff Report.

The proposed project requires a DRP for two reasons, for development on a coastal bluff top property or on the face or toe of a bluff for which a coastal development permit will be required the California Coastal Commission, and for new construction, including replacement of an existing structure or structural additions to existing development in residential zones where the total of existing square footage plus proposed new square footage of the structure exceeds 60 percent of the maximum floor area allowable under the applicable floor area ratio.

CITY COUNCIL ACTION:

---

---

---

The issue before the Council is whether to approve, approve with conditions, or deny the Applicants' request as contained in Resolution 2018-013 (Attachment 1).

**DISCUSSION**

The subject property is located on the west side of W. Circle Drive at the intersection of Circle Drive and Ocean Street, just north of the existing public beach access stairways at Tide Park. The legal lot size is 6,139 square feet, but the western side of the site (coastal bluff edge) has eroded over time and the current lot size measures 5,726 square feet in total area. The site is currently developed with a single-story, single-family residence with attached garage built in approximately 1951. The bulk of the existing residence is seaward of the required 40 ft. bluff top rear yard setback and is considered existing nonconforming.

The property is not located within any of the City's Specific Plan areas; however, it is located within the boundaries of the SROZ. The project has been evaluated for conformance with the policies contained in the City's Certified LCP LUP, regulations of the SROZ, and the Solana Beach Municipal Code (SBMC) which are discussed further later in this report. As a condition of project approval, the Applicants would be required to obtain a Coastal Development Permit (CDP) from the California Coastal Commission (CCC) prior to the issuance of a building permit by the City.

Table 1, below, provides an overview of the applicable Certified LUP and Solana Beach Municipal Code (SBMC) specific minimum and maximum requirements of the zoning regulations for the development of the property compared to the Applicants' proposed design. As shown, the proposed height, setbacks, and floor area ratio (FAR) for the proposed structure are in compliance with the regulations of the SBMC.

<b>Table 1</b>			
<b>LOT INFORMATION</b>			
<b>Property Address:</b>	601 W. Circle Dr.	<b>Zoning Designation:</b>	MR (5-7 du/ac)
<b>Legal Lot Size:</b>	5,726 ft <sup>2</sup>	<b># of Units Allowed:</b>	1 Dwelling Unit
<b>*Actual Lot Size:</b>	6,139 ft <sup>2</sup>	<b># of Units Requested:</b>	1 Dwelling Unit
<b>Max. Allowable Floor Area:</b>	2,863 ft <sup>2</sup>	<b>Setbacks:</b>	<b>Required</b> <b>Proposed</b>
<b>Proposed Floor Area:</b>	2,384 ft <sup>2</sup>	Front (E)**	5 ft.      11.5 ft.
<b>Below Max Floor Area:</b>	479 ft <sup>2</sup>	Interior Side (N)	5 ft.      5 ft.
<b>Max. Allowable Height:</b>	25 ft.	Interior Side (S)	5 ft.      6 ft.
<b>Max. Proposed Height of addition:</b>	13.83 ft.	Rear (W)	40ft.      *** 10 ft.- 3 ft.
<b>Overlay Zone(s):</b>	SROZ	* Actual lot size is the remaining area of the lot after erosion of the bluff edge.	
<b>Proposed Fences and Walls:</b>	Yes	** LUP allows for a reduced front yard setback.	
		*** 10 ft. from property line. 3 ft. from top of bluff.	
<b>Proposed Parking:</b> The Applicants are proposing to replace the existing off-street parking space from the garage to the buildable area of the lot just south of the existing driveway as shown on the attached plans.			
<b>PROPOSED PROJECT INFORMATION</b>			

<b>Floor Area Breakdown:</b>		<b>Proposed Grading:</b> The proposed project includes a total grading quantity of 9.14 cubic yards. 1.1 cubic yard of excavation for the footings of the proposed covered front porch, 1.5 cubic yards for the proposed courtyard wall footings, 3.7 cubic yards of cut for the proposed detention basin and 2.8 cubic yards of cut and backfill for the trenching required to install the drainage lines for the proposed detention basin.
Existing Living Area:	1,544 ft <sup>2</sup>	
Garage Converted to Living Area:	281 ft <sup>2</sup>	
Covered Patio (included in FAR)	559 ft <sup>2</sup>	
<b>Total Floor Area:</b>	<b>2,384 ft<sup>2</sup></b>	
<b>Required Permits:</b>		
<p><b>DRP:</b> A DRP is required for 1. Any development on a coastal bluff top property or on the face or toe of a bluff for which a coastal development permit issued by the California Coastal Commission is presently required. 2. For any new construction, including replacement of an existing structure or structural additions to existing development in residential zones The total of existing square footage plus proposed new square footage of the structure exceeds 60 percent of the maximum floor area allowable under the applicable floor area ratio.</p>		

Geopacifica, the City's third party geotechnical engineering consultant, has reviewed the proposed project design and the geotechnical report provided by the Applicants and has concluded that the project, as proposed, is consistent with the City's LUP and SBMC geotechnical requirements. The letter from Geopacifica is included as Attachment 2.

City Council Resolution 2018-013 (Attachment 3) provides the full text of the pertinent DRP regulations. Staff has prepared draft findings for approval of the project for Council's consideration based upon the information in this report and Staff's analysis of the proposed project. It provides the applicable LUP and SBMC sections in italicized text. Conditions from the Planning, Engineering and Fire Departments have been incorporated into the Resolution of Approval. The Council may direct Staff to modify the Resolution to reflect the findings and conditions as it deems appropriate as a part of the public hearing process. If the Council determines the project is to be denied, Staff will prepare a Resolution of Denial for an action to be taken at a subsequent Council meeting.

The following is a discussion of compliance with the policies of the LCP LUP as well as the findings for a DRP (as each applies to the proposed project) and a discussion of the development plans and recommended conditions as contained in the attached Resolution.

**Local Coastal Program (LCP) Land Use Plan (LUP):**

The City's LUP applies citywide as the entire City is located within the Coastal Zone. Therefore, in addition to compliance with the City's Municipal Code and General Plan, the project's conformance with the certified LUP is also evaluated.

The LUP contains specific policies, provisions and regulations related to properties located on the coastal bluff including those related to bluff edge setbacks, existing legal non-conforming structures and the removal of permanent irrigation systems located within 100 feet of the bluff edge.

The key relevant policies from the City's Certified LUP which apply to this project are listed below in italics for reference followed by an analysis of the how the proposed project is designed in compliance with the respective Certified LUP policy:

***Policy 4.14:*** Existing, lawfully established structures that are located between the sea and the first public road paralleling the sea (or lagoon) built prior to the adopted date of the LUP that do not conform to the provisions of the LCP shall be considered legal non-conforming structures. Such structures may be maintained and repaired, as long as the improvements do not increase the size or degree of non-conformity. Additions and improvements to such structures that are not considered Bluff Top Redevelopment, as defined herein, may be permitted provided that such additions or improvements themselves comply with the current policies and standards of the LCP. Complete demolition and reconstruction or Bluff Top Redevelopment is not permitted unless the entire structure is brought into conformance with the policies and standards of the LCP.

***Policy 4.17:*** New development shall be set back a safe distance from the bluff edge, with a reasonable margin of safety, to eliminate the need for bluff retention devices to protect the new improvements. All new development, including additions to existing structures, on bluff property shall be landward of the Geologic Setback Line (GSL) as set forth in Policy 4.25. This requirement shall apply to the principal structure and accessory or ancillary structures such as guesthouses, pools, tennis courts, cabanas, and septic systems, etc. Accessory structures such as decks, patios, and walkways, which are at-grade and do not require structural foundations may extend into the setback area no closer than five feet from the bluff edge. On lots with a legally established bluff retention device, the required geologic analysis shall describe the condition of the existing seawall; identify any impacts it may be having on public access and recreation, scenic views, sand supply and other coastal resources; and evaluate options to mitigate any previously unmitigated impacts of the structure or modify, replace or remove the existing protective device in a manner that would eliminate or reduce those impacts.

The proposed project consists of a remodel of an existing home that was constructed in approximately 1951. The majority of the existing home is seaward of the required 40 foot setback from the bluff edge as required by the LUP. There are two decks and a patio attached to the rear of the existing residence that are proposed to remain. The outer face of the western wall of the residence is approximately 20 feet from the rear property line. The bluff edge has eroded over time such that the outer face of the western most wall of the residence at the northwestern corner of the residence is approximately 13 feet from the bluff edge. The exterior deck in that corner of the lot is approximately 4 feet from the bluff edge.



The Applicants are proposing to convert the existing enclosed 1-car garage to living area and construct a new patio cover/roof over an existing courtyard in the front yard. A portion of the new patio roof/cover is seaward of the 40 foot setback line, however, the new footings to support the patio cover would be landward of both the 40 setback and the GSL in compliance with policy 4.17. All existing improvements located closer than five feet of the coastal bluff edge(hardscape and fencing) will be removed as part of the project as required by the LUP.

The property has required five foot side yard setbacks along the north and south side yards as well as along the front (landward or east) side of the property. No portion of the proposed patio roof/cover would encroach into the required 5 foot minimum front yard setback. An existing chimney and bay window will continue to encroach into the required north side yard setback and an existing deck will continue to encroach into the required southern side yard setback. The existing structures encroach approximately 1 to 2 feet.

The GSL and bluff stability requirements of the LUP are provided under LUP Policy 4.25. The geotechnical analysis prepared by the Terra Pacific Consultants Inc. and the supplements from Geotechnical Exploration, Inc. are provided in Attachment 3 and are further discussed below.

***Policy 4.25:*** All new bluff property development shall be set back from the bluff edge a sufficient distance to ensure that it will not be in danger from erosion and that it will ensure stability for its projected 75 year economic life. To determine the GSL, applications for bluff property development must include a geotechnical report, from a licensed Geotechnical Engineer or a certified Engineering Geologist that establishes the Geologic Setback Line (GSL) for the proposed development. This setback line shall establish the location on the bluff top stability where it can be reasonably assured for the economic life of the development. Such assurance will take the form of a quantitative slope analysis demonstrating a minimum factor of safety against sliding of 1.5 (static) or 1.2 (pseudostatic,  $k=0.15$  or determined through analysis by the geotechnical engineer), using shear strength parameters derived from relatively undeformed samples collected at the site. In no case shall the setback be less than 40 feet from the bluff edge, and only if it can be demonstrated that the structure will remain stable, as defined above, at such a location for its 75-year economic life and has been sited safely without reliance on existing or future bluff retention devices, other than a caisson foundation.

The remodeled residence maintains the same rear yard setback as the existing residence and would not encroach further west into the rear yard setback. Therefore, the existing non-conformity would remain and the proposed improvements would not increase the size or degree of the existing legal non-conformity.

The geotechnical report was peer-reviewed by the City's third party geotechnical engineer, Geopacifica (Attachment 2), who confirmed that the bluff erosion rate analysis

and related stability calculations provided by the Applicants' geotechnical engineers and proposed project design are consistent with the City's Certified LUP policies and applicable SBMC requirements.

***Policy 4.26:*** *With respect to bluff properties only, the City will require the removal or capping of any permanent irrigation system within 100 feet of the bluff edge in connection with issuance of discretionary permits for new development, redevelopment, or shoreline protection, or bluff erosion, unless the bluff property owner demonstrates to the satisfaction of the Public Works Director, or the CCC if the project is appealed, that such irrigation has no material impact on bluff erosion (e.g., watering hanging plants over hardscape which drains to the street).*

The proposed project has been conditioned to require the removal or capping of any/all onsite permanent irrigation systems located within 100 feet of the bluff edge.

Chapter 8 of the LUP (Definitions) contains the threshold listed below that is used by the City to evaluate whether a proposed project is considered a remodel or whether it meets the definition of a "Bluff Top Redevelopment" project.

*Bluff Top Redevelopment shall apply to proposed development located between the sea and the first public road paralleling the sea (or lagoon) that consists of alterations including (1) additions to an existing structure, (2) exterior and/or interior renovations, (3) and/or demolition of an existing bluff home or other principal structure, or portions thereof, which results in:*

*(a) Alteration of 50% or more of major structural components including exterior walls, floor and roof structure, and foundation, or a 50% increase in floor area. Alterations are not additive between individual major structural components; however, changes to individual major structural components are cumulative over time from the date of certification of the LUP.*

*(b) Demolition, renovation or replacement of less than 50% of a major structural component where the proposed alteration would result in cumulative alterations exceeding 50% or more of a major structural component, taking into consideration previous alterations approved on or after the date of certification of the LUP; or an alteration that constitutes less than 50% increase in floor area where the proposed alteration would result in a cumulative addition of greater than 50% of the floor area taking into consideration previous additions approved on or after the date of certification of the LUP.*

The proposed project will maintain all existing setbacks, is below the maximum building height and maximum allowable floor area, therefore, does not increase the size or the degree of the existing legal non-conformity.

As shown in Table 3, the proposed project is below all thresholds listed above and is therefore not considered a Bluff Top Redevelopment project and is not subject to Certified LUP Policy 4.29.

**Table 3 – Project Comparison to Bluff Top Redevelopment Thresholds**

Structural Component	Existing	Proposed or Modified	Percent Change / Difference	LUP Threshold Exceeded?
Exterior Walls	262'-10"	78'-9"	29.96%	No
Floor Area	1,625 SF	2,384 SF	46.70%	No
Floor Structure	1,825 SF	364 SF	19.94%	No
Roof Structure	2,406 SF	1,018 SF	42.31%	No
Foundation	1,825 SF	364 SF	19.94%	No

The property is located north of Tide Park Beach public beach access easement which provides public coastal access to the public beach below. Cardiff State Beach, within the boundaries of the City of Encinitas, is directly below the property.

According to the geotechnical report prepared by TerraCosta Consulting Group (for a previously proposed two-story project on the site) and the recent updates to the geotechnical reports to reflect the current project performed by Geotechnical Exploration, Inc. (GEi) included in Attachment 4, the combined 1.5 Factor of Safety and theoretical 75-year bluff erosion line (Geologic Setback Line or GSL) is located approximately 45 feet from the bluff edge and runs through the eastern portion of the residence made up of a bedroom on the southern side and the garage on the northern side. Because there are no changes to the footprint of the residence, this is informative but does not affect the project as proposed. The location of the GSL would be relevant if this project was a Bluff Top Remodel as it would indicate the location of new development.

The LUP recommends the use of 0.40 feet per year as the default average annual bluff erosion rate unless a site specific geotechnical analysis indicates a different erosion rate should be used. LUP Policy 4.25 allows for the use of a site specific rate and stipulates that any existing shoreline protective devices shall be excluded from the slope stability calculations (Policy 4.18).

A site specific bluff erosion rate analysis was conducted by GEi, as allowed by Certified LUP Policy 4.25, and determined to be 0.1875 feet per year. This analysis was reviewed and confirmed by the City's Third Party geotechnical engineer, Geopacifica.

**Development Review Permit Compliance:**

In addition to meeting zoning requirements, the project must also be found in compliance with development review criteria. The proposed project requires a DRP for development on a coastal bluff top property that requires a coastal development permit issued by the CCC and for replacement of an existing structure or structural additions to

existing development in residential zones that exceeds 60 percent of the maximum floor area allowable under the applicable floor area ratio.

The following is a list of the development review criteria topics:

1. Relationship with Adjacent Land Uses
2. Building and Structure Placement
3. Landscaping
4. Roads, Pedestrian Walkways, Parking and Storage Areas
5. Grading
6. Lighting
7. Usable Open Space

The Council may approve, or conditionally approve, a DRP only if all of the findings listed below can be made. Resolution 2018-013 (Attachment 1) provides the full discussion of the following findings.

1. The proposed development is consistent with the general plan and all applicable requirements of this title, including special regulations, overlay zones, and specific plans.
2. The proposed development complies with the development review criteria set forth in subsection F of this section.
3. All required permits and approvals issued by the city, including variances, conditional use permits, comprehensive sign plans, and coastal development permits have been obtained prior to or concurrently with the development review permit.
4. If the development project also requires a permit or approval to be issued by a state or federal agency, the city council may conditionally approve the development review permit upon the applicant obtaining the required permit or approval from the other agency.

If the above findings cannot be made, the Council shall deny the DRP. The following is a discussion of the applicable development review criteria as they relate to the proposed project.

#### Relationship with Adjacent Land Uses:

The property is located within the MR Zone. Other nearby properties are also located within the MR Zone and are developed with one and two-story, single-family residences. The project site is currently developed with a split-level, single-family residence.

The project, as designed, is consistent with the permitted uses for the MR Zone as described in SBMC Sections 17.20.010 and 17.12.020. The property is designated Medium Density Residential in the General Plan and intended for single-family

residences developed at a maximum density of five to seven dwelling units per acre. The proposed development could be found to be consistent with the objectives of the General Plan as it encourages the development and maintenance of healthy residential neighborhoods, the stability of transitional neighborhoods, and the rehabilitation of deteriorated neighborhoods.

The property is not located within any of the City's Specific Plan areas; however, it is located within the boundaries of the SROZ and within the Coastal Zone. The project has been evaluated, and could be found to be in conformance with, the regulations of the SROZ, which are discussed further in this report. As a condition of project approval, the Applicants would be required to obtain a Coastal Development Permit, Waiver or Exemption from the California Coastal Commission prior to the issuance of a Building Permit.

#### Building and Structure Placement:

The Applicants propose to remodel the existing single-story structure, convert the existing attached garage into living area and construct a patio cover enclosing an existing uncovered courtyard at the front entry of the residence. The covered patio would be enclosed on three sides by full sized walls and is, therefore, included in the calculation of floor area. Driveway access would be maintained at the northeast corner of the lot, however, because the garage would be converted to living area, the required parking space would be provided within the buildable area of the property south of the existing driveway.

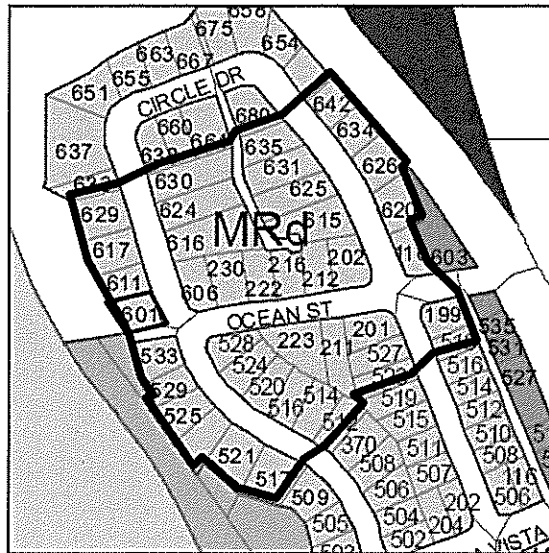
The project includes the construction of a detention basin that would drain toward the street in the southeast corner of the lot. The Applicants are proposing to maintain the existing wood fence that surrounds the north, east and southern sides of the lot. A trash enclosure would be located on the north side of the residence within the side-yard setback and would be screened by fencing from neighboring properties and the public right-of-way.

The existing 281 square foot garage would be converted to living space. Approximately 192 square feet would be used for a new dining room. The remainder of the garage area would be used as a laundry room. The remainder of the residence would be remodeled so that the living area consists of a laundry room, dining room, kitchen, family room and three bedrooms and four bathrooms.

The total proposed floor area would be 2,384 square feet, which is 479 square-feet below the maximum allowable Floor Area for the 5,726 square-foot lot, pursuant to the SROZ regulations. The maximum floor area calculation for this project is  $5,726 \text{ square feet} \times .50 = 2,863 \text{ square feet}$ . The proposed project, as designed, meets the minimum required setbacks the maximum allowable floor area for the property.

#### Neighborhood Comparison:

Staff compared the proposed project to properties within the surrounding area located along both sides of Pacific Avenue as shown on the map below.



All of the properties are located within the MR Zone and also located within the SROZ; therefore, they have a maximum FAR allowance using a tiered calculation of .50 for the first 6,000 SF of lot area, 0.175 for the next 9,000 SF, .10 for the next 5,000 SF and 0.05 for the remainder of the lot. The maximum allowable FAR for this 5,726 SF lot is calculated as follows:

$$0.50 \times 5,726 \text{ SF lot} = 2,863 \text{ SF}$$

The project was compared to 40 other existing homes in the surrounding area. Existing homes range in size from 884 SF to 4,897 SF, according to the County Assessor records. It should be noted that the County Assessor does not include the garage, covered porch area, unfinished basement or accessory building area in their total square footage. Accordingly, the building area of the proposed project has been calculated for comparison purposes by deleting the area of the covered porch as follows:

Proposed Floor Area:	2,384 SF
<u>Delete Covered Porch :</u>	<u>- 559 SF</u>
Project Area for Comparison to Assessor's Data	1,825 SF

The table below is based upon the County Assessor's data and SanGIS data. It contains neighboring lot sizes, the square footage of existing development and the maximum allowable square footage for potential development on each lot based on the original lot size not the current (gross) lot size that in many cases has been reduced in size due to coastal bluff erosion.

<b>Table 2:</b>						
#	Property Address	Lot Size in ft <sup>2</sup> (GIS)	Existing ft <sup>2</sup> Onsite (Assessor's)	Proposed / Recently Approved ft <sup>2</sup>	Max. Allowable ft <sup>2</sup> S.R.O.Z.	Zone
<b>1</b>	<b>601 W. Circle Drive</b>	<b>6,142</b>	<b>1,509</b>	<b>1,825</b>	<b>3,025</b>	<b>MR</b>
2	611 W. Circle Drive	6,014	2,010		3,002	MR
3	617 W. Circle Drive	9,094	2,535		6,541	MR
4	629 W. Circle Drive	9,199	2,283		3,550	MR
5	642 W. Circle Drive	6,259	2,266		3,045	MR
6	634 W. Circle Drive	6,230	1,555		3,040	MR
7	626 W. Circle Drive	8,338	1,678		3,409	MR
8	620 W. Circle Drive	8,182	1,602		3,382	MR
9	604 E. Circe Drive	6,696	1,498		3,122	MR
10	616 W. Circle Drive	15,655	2,409		4,641	MR
11	606 W. Circle Drive	7,597	2,924		3,279	MR
12	230 Ocean Street	7,884	3,161		3,330	MR
13	222 Ocean Street	6,899	3,141		3,157	MR
14	216 Ocean Street	5,817	1,548	4,089*	2,906	MR
15	212 Ocean Street	6,422	1,452		3,074	MR
16	202 Ocean Street	8,733	2,016		3,478	MR
17	615 E. Circle Drive	11,853	2,913		4,024	MR
18	625 E. Circle Drive	9,898	3,392		3,682	MR
19	631 E. Circle Drive	9,845	2,739		3,673	MR
20	635 E. Circle Drive	7,411	2,517		3,072	MR
21	630 W. Circle Drive	11,603	2,135		3,247	MR
22	624 W. Circle Drive	10,788	2,350		3,839	MR
23	533 Pacific Avenue	8,279	2,917		3,399	MR
24	529 Pacific Avenue	6,016	1,609		3,003	MR
25	521 Pacific Avenue	11,469	3,431		3,957	MR
26	525 Pacific Avenue	7,857	3,408		3,345	MR
27	0 Pacific Avenue	8,489	VACANT		3,436	MR
28	517 Pacific Avenue	10,686	2,912		3,820	MR
29	528 Pacific Avenue	5,963	2,647		2,982	MR
30	524 Pacific Avenue	7,049	4,897**		3,184	MR
31	520 Pacific Avenue	6,855	3,774**		3,150	MR
32	223 Ocean Street	12,679	2,618	4,036	4,169	MR
33	211 Ocean Street	8,314	1,259		3,405	MR
34	201 Ocean Street	7,729	1,897		3,303	MR
35	527 N. Acacia Avenue	6,364	884		3,064	MR
36	523 N. Acacia Avenue	6,786	1,016		3,138	MR
37	514 Pacific Avenue	7,339	1,542		3,234	MR
38	512 Pacific Avenue	6,731	1,414		3,128	MR

39	516 Pacific Avenue	6,344	1,827		3,060	MR
40	199 Ocean Street	6,541	2,733		3,095	MR
41	518 N. Acacia Avenue	4560	2,730**		2,280	MR

\* This square footage includes the basement square footage of 1,702 square feet, which the Assessor includes in the square footage calculation but the City does not.

\*\* These structures exceed the maximum allowable floor area for the lot because they were built prior to the adoption of the SROZ, which reduced the maximum floor area for the lots.

#### Fences, Walls and Retaining Walls:

The SBMC allows for fences and walls or any combination thereof, to be no higher than 42 inches in height as measured from existing grade within the front yard setback. Fences, walls and retaining walls located within the rear and interior side yards are allowed to be up to six feet in height with an additional 24 inches that is 50% open to light and air. The plans indicate that an existing 6 foot high fence is currently located along the north, east and southern sides of the property. Portions of the existing fence along the east and southern sides of the property encroach into the public right-of-way of W. Circle Drive and also into the public beach access right-of-way. With the proposed project, the fence that is on the northern property line will be maintained and the fence within the right-of-way will be removed and will be reconstructed at the property line. The fence along the eastern property line will be brought into conformance with the maximum fence height regulations for fences within the front yard setback. Any portion of the fence that is on the property line and proposed to remain that is considered nonconforming because of the height is permitted to remain according to SBMC Section 17.16.100 which indicates that any nonconforming wall or fence shall be allowed to remain in perpetuity, provided that the size or degree of the nonconformity is not increased. A condition of approval has been added to the resolution that indicates that any proposed onsite fences, walls and any proposed railing located on top or any combination thereof shall comply with applicable regulations of SBMC Section 17.20.040 and 17.60.070 (Fences and Walls).

#### Landscape:

The project is not subject to the water efficient landscaping regulations of SBMC Chapter 17.56. According to SBMC Section 17.56.040, the regulations apply to modified irrigated landscaped areas that exceed 500 square feet. As designed, approximately 226 square feet of landscaped area will be removed in order to construct the required detention basin and the trenching necessary to lay the drainage lines for the required basin.

The project has been conditioned to require that any new bluff property landscaping shall consist of native, non-invasive, drought-tolerant, fire-resistant, and salt-tolerant species. The LCP Policy 4.26 requires the Applicants to cap or remove any permanent irrigation systems onsite unless the bluff property owner demonstrates, to the



satisfaction of the City Engineer, that such irrigation has no material impact on bluff erosion.

#### Parking:

The existing attached 281 square foot garage is located in the northeast corner of the property and accessed along the northern elevation from an existing driveway in the northeast corner of the property. With the proposed project, the existing driveway would remain in the same location. The existing single car garage would be converted to living area. Approximately 192 square feet of the garage would be converted to a new dining area and the remainder of the existing garage would be converted to a laundry room. As designed, the existing garage door would remain on the eastern wall of the proposed laundry room.

SBMC Section 17.52.040 and the Off-Street Parking Design Manual (OSPDM) require each single-family residence to provide two off-street parking spaces that are 9' X 19' clear. LCP Policy 4.23 allows the City to reduce the off-street parking requirement to one parking space when the setbacks and other development standards could preclude the construction of a home. The Applicants are proposing to replace the existing off-street parking space from the garage to the buildable area of the lot just south of the existing driveway as shown on the attached plans.

#### Grading:

The proposed project includes a total grading quantity of 9.14 cubic yards. The grading is proposed for the following: 1.1 cubic yard of excavation for the footings of the proposed covered front porch, 1.5 cubic yards for the proposed courtyard wall footings, 3.7 cubic yards of cut for the proposed detention basin and 2.8 cubic yards of cut and backfill for the trenching required to install the drainage lines for the proposed detention basin.

#### Lighting:

A condition of project approval includes that all new exterior lighting fixtures comply with the City-Wide Lighting Regulations of the Zoning Ordinance (SBMC 17.60.060). All light fixtures shall be shielded so that no light or glare is transmitted or reflected in such concentrated quantities or intensities as to be detrimental to the surrounding area.

#### Useable Open Space:

The project consists of the remodeling of an existing single-family residence, attached garage and associated site improvements, therefore, usable open space and recreational facilities are not required according to SBMC 17.20.040.

#### Public Hearing Notice:

Notice of the City Council Public Hearing for this project was published in the San Diego Union Tribune more than 10 days prior to the public hearing. The same public notice was mailed to property owners and occupants within 300 feet of the proposed project site on February 2, 2018. As of the date of preparation of this Staff Report, Staff has not received any letters, phone calls, or emails from neighbors or interested parties in support of, or in opposition to, the proposed project.

In conclusion, if the Council can make the required findings, the proposed project, as conditioned, could be found in compliance with the requirements of the Certified LUP, Zoning Ordinance, and the General Plan, and could be found to meet the findings required to approve a DRP.

**CEQA COMPLIANCE STATEMENT:**

The project is exempt from the California Environmental Quality Act (CEQA) pursuant to Section 15303 (Class 3 Exemption) of the 2017 State CEQA Guidelines which is an exemption for the construction and location of limited numbers of new, small facilities or structures. Examples of this exemption include, but are not limited to:

- One single-family residence, or a second dwelling unit in a residential zone. In urbanized areas, up to three single-family residences may be constructed or converted under this exemption.

**FISCAL IMPACT:** N/A

**WORK PLAN:** N/A

**OPTIONS:**

- Approve Staff recommendation adopting the attached Resolution 2018-013.
- Approve Staff recommendation subject to additional specific conditions necessary for the City Council to make all required findings for the approval of a DRP.
- Deny the project if all required findings for the DRP cannot be made.

**DEPARTMENT RECOMMENDATION:**


The proposed project meets the minimum objective requirements under the LUP, SBMC, is consistent with the General Plan and may be found, as conditioned, to meet the discretionary findings required as discussed in this report to approve a DRP. Therefore, Staff recommends that the City Council:

1. Conduct the Public Hearing: Open the Public Hearing, Report Council Disclosures, Receive Public Testimony, and Close the Public Hearing.
2. Find the project exempt from the California Environmental Quality Act pursuant to Section 15303 of the State CEQA Guidelines; and

3. If the City Council makes the requisite findings and approves the project, adopt Resolution 2018-015 conditionally approving to convert the existing garage to living area, add a covered patio and remodel the interior of an existing single-story residence on property at 601 W. Circle Drive.

**CITY MANAGER'S RECOMMENDATION:**

Approve Department Recommendation.



\_\_\_\_\_  
Gregory Wade, City Manager

Attachments:

1. Resolution 2018-013
2. Project Plans dated February 7, 2018
3. GeoSoils Geotechnical Report
4. Correspondence from Geopacifica, Inc.

**RESOLUTION 2018-013**

**A RESOLUTION OF THE CITY COUNCIL OF THE CITY OF SOLANA BEACH, CALIFORNIA, CONDITIONALLY APPROVING A DEVELOPMENT REVIEW PERMIT AND TO REMODEL AN EXISTING SINGLE-FAMILY RESIDENCE, CONVERT THE EXISTING ATTACHED GARAGE TO LIVING SPACE, CONSTRUCT A NEW COVERED PATIO AND ASSOCIATED SITE IMPROVEMENTS ON PROPERTY AT 601 W. CIRCLE DRIVE, SOLANA BEACH**

**APPLICANTS: SCOTT AND LISA HARRIS  
CASE NO.: 17-17-23 DRP**

**WHEREAS**, Scott and Lisa Harris (hereinafter referred to as "Applicants") have submitted an application for a Development Review Permit (DRP) pursuant to Title 17 (Zoning), of the Solana Beach Municipal Code (SBMC); and

**WHEREAS**, the Public Hearing was conducted pursuant to the provisions of Solana Beach Municipal Code Section 17.72.030; and

**WHEREAS**, at the Public Hearing on February 14, 2018, the City Council received and considered evidence concerning the proposed application; and

**WHEREAS**, the City Council of the City of Solana Beach found the application request exempt from the California Environmental Quality Act pursuant to Section 15303 of the State CEQA Guidelines; and

**WHEREAS**, this decision is based upon the evidence presented at the hearing and any information the City Council gathered by viewing the site and the area as disclosed at the hearing.

**NOW THEREFORE**, the City Council of the City of Solana Beach, California, does resolve as follows:

1. That the foregoing recitations are true and correct.
2. That the request for a DRP to convert the existing garage to living area, add a covered patio and remodel the interior of an existing single-story residence on property at 601 W. Circle Drive is conditionally approved based upon the following findings and subject to the following conditions:
3. FINDINGS
  - A. In accordance with Section 17.68.040 (Development Review Permit) of the City of Solana Beach Municipal Code, the City Council finds the following:

- I. *The proposed project is consistent with the General Plan and all applicable requirements of SBMC Title 17 (Zoning Ordinance), including special regulations, overlay zones and specific plans.*

General Plan Consistency: The proposed project, as conditioned, is consistent with the City's General Plan designation of Medium Density Residential, which allows for single-family residential development with a maximum density of 5-7 dwelling units per acre. Further, the proposed development is consistent with the objectives of the General Plan as it encourages the development and maintenance of healthy residential neighborhoods, the stability of transitional neighborhoods, and the rehabilitation of deteriorated neighborhoods.

Local Coastal Program Land Use Plan Consistency: The proposed project is consistent with all applicable requirements of the City's certified Local Coastal Program Land Use Plan including key policies related to bluff edge setbacks for new development, use of caissons, cantilevered design components and definitions.

Zoning Ordinance Consistency: The proposed project is consistent with all applicable requirements of the Zoning Ordinance (Title 17) (SBMC 17.20.030 and 17.48.040), which delineates maximum allowable Floor Area Ratio (FAR), Permitted Uses and Structures (SBMC Section 17.20.020), which provides for uses of the property for a single-family residence. Further, the proposed project adheres to all property development regulations established for the Medium Residential (MR) Zone and cited by SBMC Section 17.020.030 as well as the specific development regulations of the Scaled Residential Overlay Zone (SROZ) cited in SBMC Section 17.48.040.

The design of the proposed project is consistent with the provisions for minimum yard dimensions (i.e., setbacks) and the maximum FAR, maximum building height, and parking requirements. Prior to building permit issuance, the project will be reviewed for compliance with the landscape regulations as established by SBMC Section 17.56.

- II. *The proposed development complies with the following development review criteria set forth in Solana Beach Municipal Code Section 17.68.040.F:*

- a. *Relationship with Adjacent Land Uses: The development shall be designed in a manner compatible with and where feasible, complimentary to existing and potential development in the immediate vicinity of the project site. Site planning on the perimeter of the development shall give consideration to the*

*protection of surrounding areas from potential adverse effects, as well as protection of the property from adverse surrounding influences.*

The property is located within the MR Zone. Other nearby properties are also located within the MR Zone and are developed with one and two-story, single-family residences. The project site is currently developed with a split-level, single-family residence.

The project, as designed, is consistent with the permitted uses for the MR Zone as described in SBMC Sections 17.20.010 and 17.12.020. The property is designated Medium Density Residential in the General Plan and intended for single-family residences developed at a maximum density of five to seven dwelling units per acre. The proposed development could be found to be consistent with the objectives of the General Plan as it encourages the development and maintenance of healthy residential neighborhoods, the stability of transitional neighborhoods, and the rehabilitation of deteriorated neighborhoods.

The property is not located within any of the City's Specific Plan areas; however, it is located within the boundaries of the SROZ and within the Coastal Zone. The project has been evaluated, and could be found to be in conformance with, the regulations of the SROZ, which are discussed further in this report. As a condition of project approval, the Applicants would be required to obtain a Coastal Development Permit, Waiver or Exemption from the California Coastal Commission prior to the issuance of a Building Permit.

- b. Building and Structure Placement: Buildings and structures shall be sited and designed in a manner which visually and functionally enhances their intended use.*

The Applicants propose to remodel the existing single-story structure, convert the existing attached garage into living area and construct a patio cover enclosing an existing uncovered courtyard at the front entry of the residence. The covered patio would be enclosed on three sides by full sized walls and is, therefore, included in the calculation of floor area. Driveway access would be maintained at the northeast corner of the lot, however, because the garage would be converted to living area, the required parking space would be provided within the buildable area of the property south of the existing driveway.

The project includes the construction of a detention basin that would drain toward the street in the southeast corner of the lot. The Applicant is proposing to maintain the existing wood fence that surrounds the north, east and southern sides of the lot. A trash enclosure would be located on the north side of the residence within the side-yard setback and would be screened by fencing from neighboring properties and the public right-of-way.

The existing 281 square foot garage would be converted to living space. Approximately 192 square feet would be used for a new dining room. The remainder of the garage area would be used as a laundry room. The remainder of the residence would be remodeled so that the living area consists of a laundry room, dining room, kitchen, family room and three bedrooms and four bathrooms.

The total proposed floor area would be 2,384 square feet, which is 479 square-foot below the maximum allowable Floor Area for the 5,726 square-foot lot, pursuant to the SROZ regulations. The maximum floor area calculation for this project is  $5,726 \text{ Square feet} \times .50 = 2,863 \text{ square feet}$ . The proposed project, as designed, meets the minimum required setbacks the maximum allowable floor area for the property.

- c. *Landscaping: The removal of significant native vegetation shall be minimized. Replacement vegetation and landscaping shall be compatible with the vegetation of the surrounding area. Trees and other large plantings shall not obstruct significant views when installed or at maturity.*

The project is not subject to the water efficient landscaping regulations of SBMC Chapter 17.56. According to SBMC Section 17.56.040, the regulations apply to modified irrigated landscaped areas that exceed 500 square feet. As designed, approximately 226 square feet of landscaped area will be removed in order to construct the required detention basin and the trenching necessary to lay the drainage lines for the required basin.

The project has been conditioned to require that any new bluff property landscaping shall consist of native, non-invasive, drought-tolerant, fire-resistant, and salt-tolerant species. The LCP Policy 4.26 requires the Applicant to cap or remove any permanent irrigation systems onsite unless the bluff property

owner demonstrates, to the satisfaction of the City Engineer, that such irrigation has no material impact on bluff erosion.

- d. *Roads, Pedestrian Walkways, Parking and Storage Areas: Any development involving more than one building or structure shall provide common access roads and pedestrian walkways. Parking and outside storage areas, where permitted, shall be screened from view, to the extent feasible, by existing topography, by the placement of buildings and structures, or by landscaping and plantings.*

The existing attached 281 square foot garage is located in the northeast corner of the property and accessed along the northern elevation from an existing driveway in the northeast corner of the property. With the proposed project, the existing driveway would be would remain in the same location. The existing garage would be converted to living area. Approximately 192 square feet of the garage would be converted to a new dining area and the remainder of the existing garage would be converted to a laundry room. As designed, the existing garage door would remain on the eastern wall of the proposed laundry room.

SBMC Section 17.52.040 and the Off-Street Parking Design Manual (OSPDM) require each single-family residence to provide two off-street parking spaces that are 9' X 19' clear. The LCP indicates in Policy 4.23 allows the City to reduce the off-street parking requirement to one parking space when the setbacks and other development standards could preclude the construction of a home. The Applicant is proposing to provide one off-street parking space in the buildable area of the lot just south of the existing driveway as shown on the attached plans.

- e. *Grading: To the extent feasible, natural topography and scenic features of the site shall be retained and incorporated into the proposed development. Any grading or earth-moving operations in connection with the proposed development shall be planned and executed so as to blend with the existing terrain both on and adjacent to the site. Existing exposed or disturbed slopes shall be landscaped with native or naturalized non-native vegetation and existing erosion problems shall be corrected.*

The proposed project includes a total grading quantity of 9.14 cubic yards. The grading is proposed for the following: 1.1 cubic yard of excavation for the footings of the proposed



covered front porch, 1.5 cubic yards for the proposed courtyard wall footings, 3.7 cubic yards of cut for the proposed detention basin and 2.8 cubic yards of cut and backfill for the trenching required to install the drainage lines for the proposed detention basin.

- f. Lighting: Light fixtures for walkways, parking areas, driveways, and other facilities shall be provided in sufficient number and at proper locations to assure safe and convenient nighttime use. All light fixtures shall be appropriately shielded so that no light or glare is transmitted or reflected in such concentrated quantities or intensities as to be detrimental to the surrounding areas per SBMC 17.60.060 (Exterior Lighting Regulations).*

A condition of project approval includes that all new exterior lighting fixtures comply with the City-Wide Lighting Regulations of the Zoning Ordinance (SBMC 17.60.060). All light fixtures shall be shielded so that no light or glare is transmitted or reflected in such concentrated quantities or intensities as to be detrimental to the surrounding area.

- g. Usable Open Space: Recreational facilities proposed within required usable open space shall be located and designed to maintain essential open space values.*

The project consists of the remodeling of an existing single-family residence, converting the attached garage top living space and associated site improvements, therefore, usable open space and recreational facilities are not required according to SBMC 17.20.040.

- III. All required permits and approvals, including variances, conditional use permits, comprehensive sign plans, and coastal development permits, have been obtained prior to or concurrently with the development review permit.*

All required permits are being processed concurrently with the Development Review Permit.

- IV. If the development project also requires a permit or approval to be issued by a state or federal agency, the city council may conditionally approve the development review permit upon the Applicants obtaining the required permit or approval from the other agency.*

The Applicants are required to obtain approval from the CCC prior to issuance of Building Permits.

#### 4. CONDITIONS

Prior to use or development of the property in reliance on this permit, the Applicants shall provide for and adhere to the following conditions:

A. Community Development Department Conditions:

- I. The Applicants shall pay required Public Facilities Fees, as established by SBMC Section 17.72.020 and Resolution 1987-36.
- II. Building Permit plans must be in substantial conformance with the plans presented to the City Council on February 14, 2018, and located in the project file with a submittal date of February 07, 2018.
- III. Prior to requesting a framing inspection, the Applicants are required to submit two height certifications signed by a licensed land surveyor certifying that the structure will not exceed 16 feet in height or 82.83 feet above MSL from the proposed finished grade.
- IV. Any proposed onsite fences, walls and any proposed railing located on top or any combination thereof shall comply with applicable regulations of SBMC Section 17.20.040 and 17.60.070 (Fences and Walls).
- V. The Applicants shall obtain required California Coastal Commission (CCC) approval of a Coastal Development Permit, Waiver or Exemption as determined necessary by the CCC, prior to the issuance of a building permit by the City.
- VI. The Applicants shall remove or cap any/all permanent irrigation systems onsite unless the bluff property owner demonstrates, to the satisfaction of the Public Works Director, that such irrigation has no material impact on bluff erosion (e.g., watering hanging plants over hardscape which drains to the street).
- VII. All new bluff property landscaping shall consist of native, non-invasive, drought-tolerant, fire-resistant, and salt-tolerant species.
- VIII. Any new exterior lighting fixtures shall be in conformance with the City-Wide Lighting Regulations of SBMC 17.60.060.
- IX. All light fixtures shall be appropriately shielded so that no light or glare is transmitted or reflected in such concentrated quantities or intensities that render them detrimental to the surrounding area.

- B. Fire Department Conditions: Please note that this list provides detailed Fire Department requirements and is not meant to be an all-inclusive plan check list of the Fire Department comments.
- I. **GATES:** All gates or other structures or devices, which could obstruct fire access roadways or otherwise hinder emergency operations, are prohibited unless they meet standards approved by the Fire Department. An approved emergency key-operated switch and/or an approved emergency traffic control-activating strobe light sensor shall be installed per Solana Beach Fire Department standards.
  - II. **ADDRESS NUMBERS: STREET NUMBERS:** Approved numbers and/or addresses shall be placed on all new and existing buildings and at appropriate additional locations as to be plainly visible and legible from the street or roadway fronting the property from either direction of approach. Said numbers shall contrast with their background, and shall meet the following minimum standards as to size: 4" high with a ½" inch stroke width for residential buildings, 8" high with a ½" stroke for commercial and multi-family residential buildings, 12" high with a 1" stroke for industrial buildings. Additional numbers shall be required where deemed necessary by the Fire Marshal, such as rear access doors, building corners, and entrances to commercial centers.
  - III. **AUTOMATIC FIRE SPRINKLER SYSTEM-ONE AND TWO FAMILY DWELLINGS:** Structures shall be protected by an automatic fire sprinkler system designed and installed to the satisfaction of the Fire Department. Plans for the automatic fire sprinkler system shall be approved by the Fire Department prior to installation.
  - IV. **CLASS "A" ROOF:** All structures shall be provided with a Class "A" Roof covering to the satisfaction of the Solana Beach Fire Department.
- C. Engineering Department Conditions:
- I. Construct a detention basin on private property which shall include a positive outflow system through the curb into the gutter at the street, per the Hydrology Study prepared by William Gregg Mack dated 8/8/17 and as shown on the Site Plan prepared by D. Scott Hall Designers dated 8/15/17. The detention basin shall include bottom and side surfaces that are completely impervious, to insure no infiltration into the bluff top property.

- II. An easement shall be recorded over the detention basin for maintenance by the property owner in perpetuity.
  - III. Obtain an Encroachment Permit in accordance with Chapter 11.20 of the Solana Beach Municipal Code, prior to the construction of any improvements within the public right-of-way including, but not limited to, the demolition and construction of surface improvements. All proposed improvements within the public right-of-way shall comply with City standards including but not limited to the Off-Street Parking Design Manual.
  - IV. Improvements shall include, but not be limited to the removal and re-construction of all sidewalk panels that are cracked, broke or removed for installation of the drain pipes.
  - V. Existing irrigation and landscaping within the public right-of-way shall be removed and any new improvements within in the public right-of-way including, but not limited to the proposed under sidewalk drains and proposed landscaping shall be subject to an Encroachment Maintenance Removal Agreement (EMRA).
  - VI. A portion of the front yard fence is located in the public right of way of Circle drive. Prior to the occupancy of the proposed building project, the applicant shall perform an accurate survey of the front property line at Circle Drive and relocate the fence on the property line/right of way line to the satisfaction of the City Engineer.
5. ENFORCEMENT: Pursuant to SBMC 17.72.120(B) failure to satisfy any and all of the above-mentioned conditions of approval is subject to the imposition of penalties as set forth in SBMC Chapters 1.1.6 and 1.18 in addition to any applicable revocation proceedings.
  6. EXPIRATION: The Development Review Permit for the project will 24 months from the date of this Resolution, unless the Applicants have obtained building permits and have commenced construction prior to that date, and diligently pursued construction to completion. An extension of the application may be granted by the City Council according to SBMC 17.72.110.
  7. INDEMNIFICATION AGREEMENT: The Applicants shall defend, indemnify, and hold harmless the City, its agents, officers, and employees from any and all claims, actions, proceedings, damages, judgments, or costs, including attorney's fees, against the City or its agents, officers, or employees, relating to the issuance of this permit including, but not limited to, any action to attack, set aside, void, challenge, or annul this development approval and any environmental document or decision. The City will promptly notify the Applicants of any claim, action, or proceeding. The City may elect to conduct its own

defense, participate in its own defense, or obtain independent legal counsel in defense of any claim related to this indemnification. In the event of such election, the Applicants shall pay all of the costs related thereto, including without limitation reasonable attorney's fees and costs. In the event of a disagreement between the City and Applicants regarding litigation issues, the City shall have the authority to control the litigation and make litigation related decisions, including, but not limited to, settlement or other disposition of the matter. However, the Applicants shall not be required to pay or perform any settlement unless such settlement is approved by the Applicants.

NOTICE TO APPLICANTS: Pursuant to Government Code Section 66020, you are hereby notified that the 90-day period to protest the imposition of the fees, dedications, reservations or other exactions described in this resolution commences on the effective date of this resolution. To protest the imposition of any fee, dedications, reservations or other exactions described in this resolution you must comply with the provisions of Government Code Section 66020. Generally the resolution is effective upon expiration of the tenth day following the date of adoption of this resolution, unless the resolution is appealed or called for review as provided in the Solana Beach Zoning Ordinance.

**PASSED AND ADOPTED** at a regular meeting of the City Council of the City of Solana Beach, California, held on the 14<sup>th</sup> day of February 2018, by the following vote:

AYES: Councilmembers –

NOES: Councilmembers –

ABSENT: Councilmembers –

ABSTAIN: Councilmembers –

\_\_\_\_\_  
GINGER MARSHALL, Mayor

APPROVED AS TO FORM:

ATTEST:

\_\_\_\_\_  
JOHANNA N. CANLAS, City Attorney

\_\_\_\_\_  
ANGELA IVEY, City Clerk

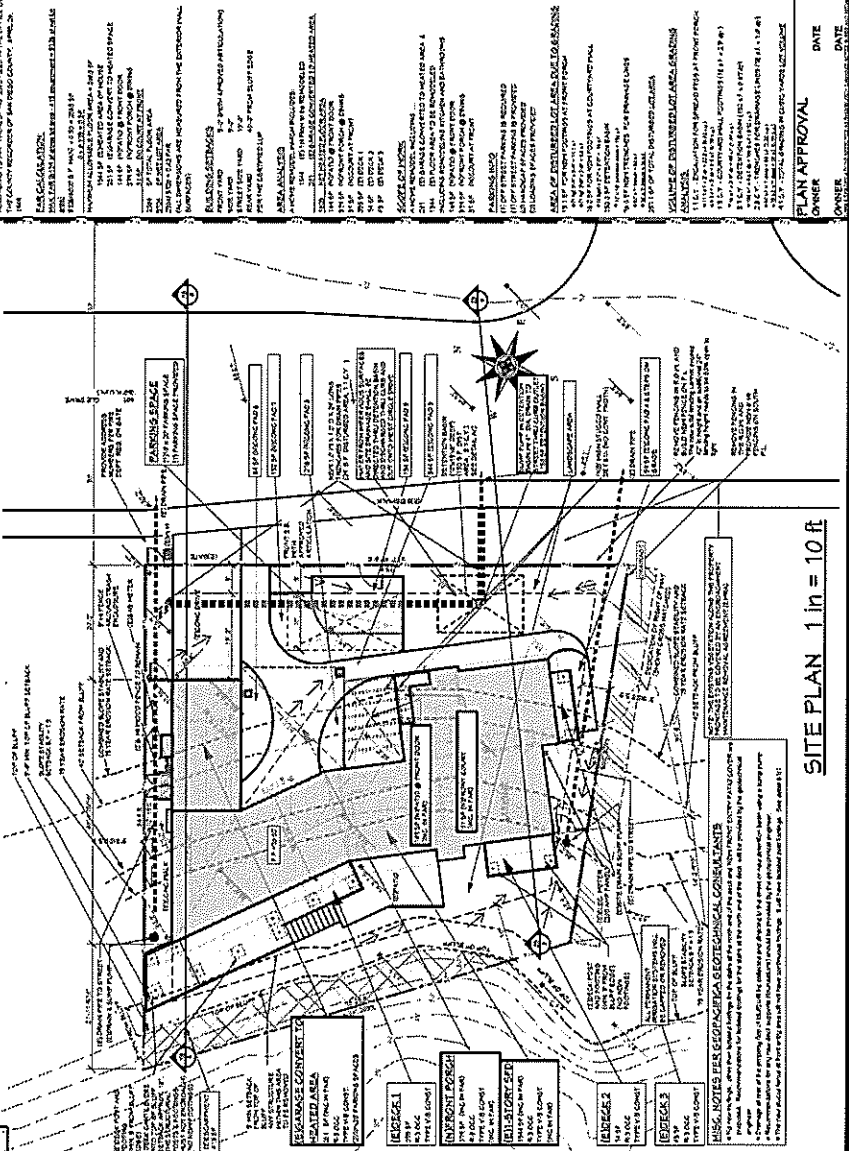
PROJECT NO.	1
SHEET NO.	1
DATE	
OWNER	

601 P. Clark Drive, Ste 200, San Diego, CA 92104  
 (619) 592-1113  
 Lisa & Scott Harris  
 Architects



Plans Prepared by  
 P. Scott Hall Designers  
 100 P. Clark Drive, Ste 200, San Diego, CA 92104  
 (619) 592-1113

REVISIONS	



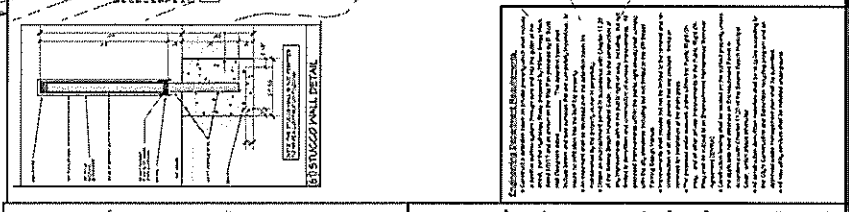
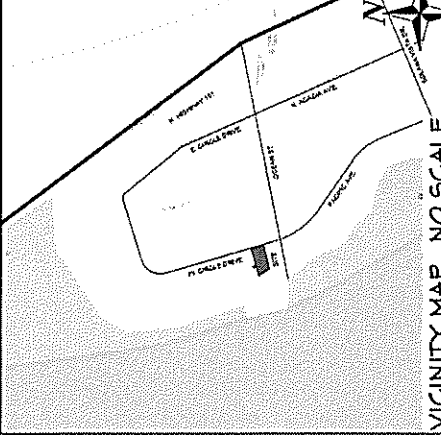
SITE PLAN 1 in = 10 ft

**GENERAL NOTES:**  
 1. ALL CONSTRUCTION SHALL BE IN ACCORDANCE WITH THE CITY OF SAN DIEGO ORDINANCES, SPECIFICATIONS AND STANDARDS.  
 2. THE DESIGNER HAS CONDUCTED VISUAL ANALYSIS AND HAS DETERMINED THAT THE PROPOSED DEVELOPMENT IS VISUALLY COMPATIBLE WITH THE SURROUNDING ENVIRONMENT.  
 3. THE DESIGNER HAS CONDUCTED VISUAL ANALYSIS AND HAS DETERMINED THAT THE PROPOSED DEVELOPMENT IS VISUALLY COMPATIBLE WITH THE SURROUNDING ENVIRONMENT.  
 4. THE DESIGNER HAS CONDUCTED VISUAL ANALYSIS AND HAS DETERMINED THAT THE PROPOSED DEVELOPMENT IS VISUALLY COMPATIBLE WITH THE SURROUNDING ENVIRONMENT.  
 5. THE DESIGNER HAS CONDUCTED VISUAL ANALYSIS AND HAS DETERMINED THAT THE PROPOSED DEVELOPMENT IS VISUALLY COMPATIBLE WITH THE SURROUNDING ENVIRONMENT.

**COMPLIANCE WITH THE 2015 ENERGY EFFICIENT STANDARDS:**  
 1. THE DESIGNER HAS CONDUCTED VISUAL ANALYSIS AND HAS DETERMINED THAT THE PROPOSED DEVELOPMENT IS VISUALLY COMPATIBLE WITH THE SURROUNDING ENVIRONMENT.  
 2. THE DESIGNER HAS CONDUCTED VISUAL ANALYSIS AND HAS DETERMINED THAT THE PROPOSED DEVELOPMENT IS VISUALLY COMPATIBLE WITH THE SURROUNDING ENVIRONMENT.  
 3. THE DESIGNER HAS CONDUCTED VISUAL ANALYSIS AND HAS DETERMINED THAT THE PROPOSED DEVELOPMENT IS VISUALLY COMPATIBLE WITH THE SURROUNDING ENVIRONMENT.

**REVISIONS:**  
 1. THE DESIGNER HAS CONDUCTED VISUAL ANALYSIS AND HAS DETERMINED THAT THE PROPOSED DEVELOPMENT IS VISUALLY COMPATIBLE WITH THE SURROUNDING ENVIRONMENT.  
 2. THE DESIGNER HAS CONDUCTED VISUAL ANALYSIS AND HAS DETERMINED THAT THE PROPOSED DEVELOPMENT IS VISUALLY COMPATIBLE WITH THE SURROUNDING ENVIRONMENT.  
 3. THE DESIGNER HAS CONDUCTED VISUAL ANALYSIS AND HAS DETERMINED THAT THE PROPOSED DEVELOPMENT IS VISUALLY COMPATIBLE WITH THE SURROUNDING ENVIRONMENT.

**REVISIONS:**  
 1. THE DESIGNER HAS CONDUCTED VISUAL ANALYSIS AND HAS DETERMINED THAT THE PROPOSED DEVELOPMENT IS VISUALLY COMPATIBLE WITH THE SURROUNDING ENVIRONMENT.  
 2. THE DESIGNER HAS CONDUCTED VISUAL ANALYSIS AND HAS DETERMINED THAT THE PROPOSED DEVELOPMENT IS VISUALLY COMPATIBLE WITH THE SURROUNDING ENVIRONMENT.  
 3. THE DESIGNER HAS CONDUCTED VISUAL ANALYSIS AND HAS DETERMINED THAT THE PROPOSED DEVELOPMENT IS VISUALLY COMPATIBLE WITH THE SURROUNDING ENVIRONMENT.

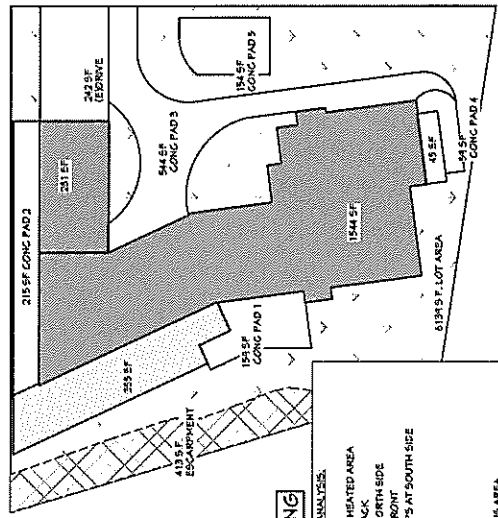


**5' STAGGED WALL DETAIL:**  
 1. THE WALL SHALL BE CONSTRUCTED IN ACCORDANCE WITH THE CITY OF SAN DIEGO ORDINANCES, SPECIFICATIONS AND STANDARDS.  
 2. THE WALL SHALL BE CONSTRUCTED IN ACCORDANCE WITH THE CITY OF SAN DIEGO ORDINANCES, SPECIFICATIONS AND STANDARDS.  
 3. THE WALL SHALL BE CONSTRUCTED IN ACCORDANCE WITH THE CITY OF SAN DIEGO ORDINANCES, SPECIFICATIONS AND STANDARDS.

**REVISIONS:**  
 1. THE DESIGNER HAS CONDUCTED VISUAL ANALYSIS AND HAS DETERMINED THAT THE PROPOSED DEVELOPMENT IS VISUALLY COMPATIBLE WITH THE SURROUNDING ENVIRONMENT.  
 2. THE DESIGNER HAS CONDUCTED VISUAL ANALYSIS AND HAS DETERMINED THAT THE PROPOSED DEVELOPMENT IS VISUALLY COMPATIBLE WITH THE SURROUNDING ENVIRONMENT.  
 3. THE DESIGNER HAS CONDUCTED VISUAL ANALYSIS AND HAS DETERMINED THAT THE PROPOSED DEVELOPMENT IS VISUALLY COMPATIBLE WITH THE SURROUNDING ENVIRONMENT.

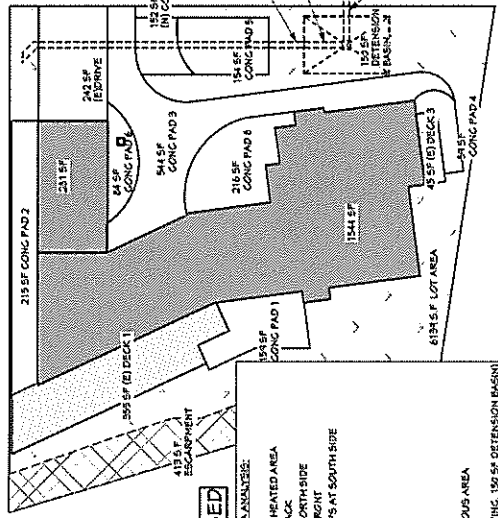
**REVISIONS:**  
 1. THE DESIGNER HAS CONDUCTED VISUAL ANALYSIS AND HAS DETERMINED THAT THE PROPOSED DEVELOPMENT IS VISUALLY COMPATIBLE WITH THE SURROUNDING ENVIRONMENT.  
 2. THE DESIGNER HAS CONDUCTED VISUAL ANALYSIS AND HAS DETERMINED THAT THE PROPOSED DEVELOPMENT IS VISUALLY COMPATIBLE WITH THE SURROUNDING ENVIRONMENT.  
 3. THE DESIGNER HAS CONDUCTED VISUAL ANALYSIS AND HAS DETERMINED THAT THE PROPOSED DEVELOPMENT IS VISUALLY COMPATIBLE WITH THE SURROUNDING ENVIRONMENT.

**FAR ANALYSIS AND IMPERVIOUS AREA ANALYSIS 1 in = 10 ft**



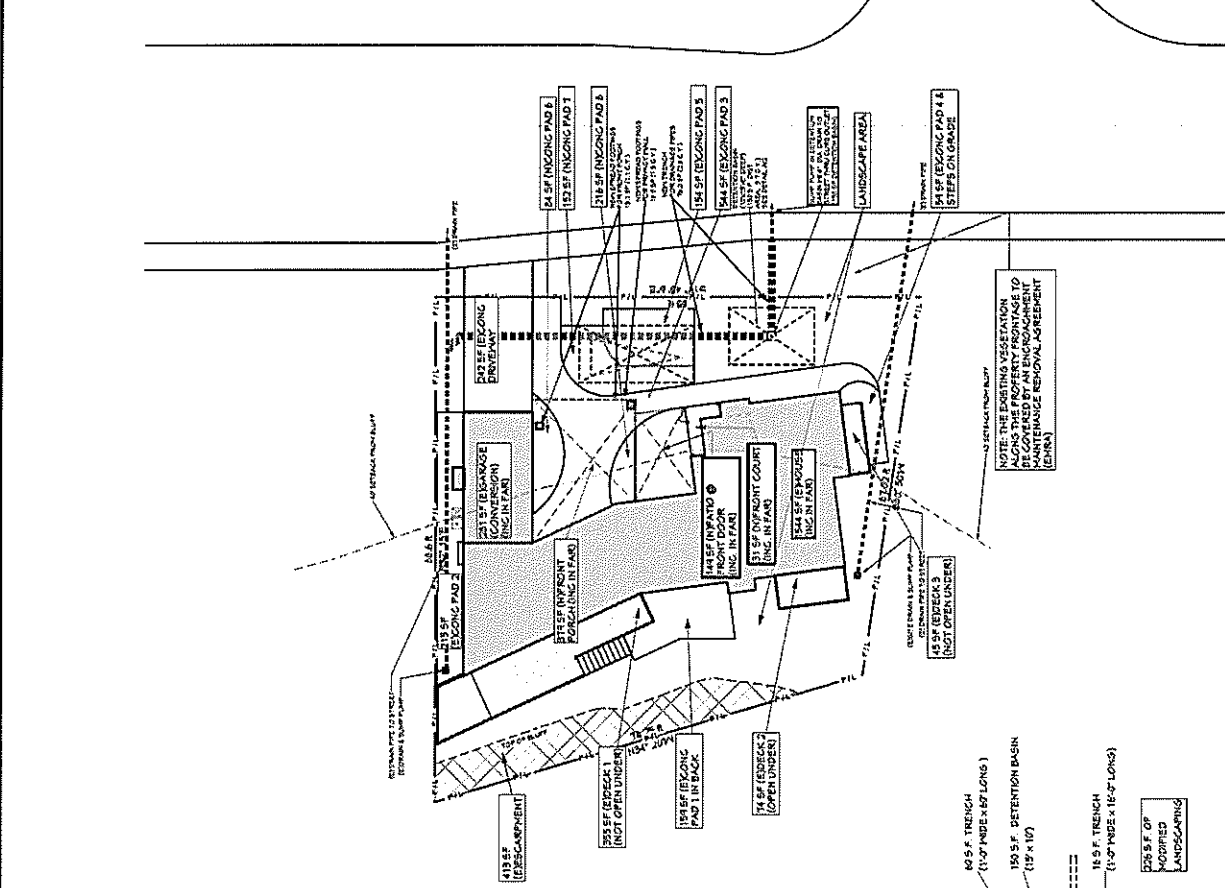
**EXISTING**

- EXISTING IMPERVIOUS AREA ANALYSIS:**
- 1544 (E) 1-STORY SID
  - 231 (E) GARAGE CONVERT TO HEATED AREA
  - 343 (E) CONCRETE PAD 2 AT NORTH SIDE
  - 194 (E) CONCRETE PAD 5 AT NORTH SIDE
  - 548 (E) CONCRETE PAD 3 AT FRONT
  - 154 (E) CONCRETE PAD 4 AT STEPS AT SOUTH SIDE
  - 242 (E) CONCRETE DRIVEWAY
  - 544 (E) DECK 1
  - 45 (E) DECK 3
  - 3912.5 F. EXISTING IMPERVIOUS AREA
  - 419.5 F. ESCARPMENT
  - 215.5 F. LANDSCAPE AREA (ING. 156.5 F. DETENTION BASIN)
  - 6194.5 F. LOT AREA



**PROPOSED**

- PROPOSED IMPERVIOUS AREA ANALYSIS:**
- 1544 (E) 1-STORY SID
  - 231 (E) GARAGE CONVERT TO HEATED AREA
  - 194 (E) CONCRETE PAD 5 AT NORTH SIDE
  - 544 (E) CONCRETE PAD 3 AT NORTH SIDE
  - 154 (E) CONCRETE PAD 4 AT STEPS AT SOUTH SIDE
  - 242 (E) CONG. PAD 5
  - 544 (E) DECK 1
  - 45 (E) DECK 3
  - 141 (E) CONG. PAD 6
  - 154 (E) CONG. PAD 3
  - 216 (E) CONG. PAD 2
  - 390.5 F. PROPOSED IMPERVIOUS AREA
  - 419.5 F. ESCARPMENT
  - 176.5 F. LANDSCAPE AREA (ING. 136.5 F. DETENTION BASIN)
  - 6194.5 F. LOT AREA



CONTRACTORS TO FIELD VERIFY ALL CONDITIONS PRIOR TO BEGINNING CONSTRUCTION AND CONSULT WITH DESIGNER IF THERE ARE ANY INCONSISTENCIES WITH EXISTING CONDITIONS AND THE PLANS	
AREA TO BE EXISTING	AREA TO BE PROPOSED
EXISTING CONCRETE PAD 1	EXISTING CONCRETE PAD 1
EXISTING CONCRETE PAD 2	EXISTING CONCRETE PAD 2
EXISTING CONCRETE PAD 3	EXISTING CONCRETE PAD 3
EXISTING CONCRETE PAD 4	EXISTING CONCRETE PAD 4
EXISTING CONCRETE PAD 5	EXISTING CONCRETE PAD 5
EXISTING CONCRETE PAD 6	EXISTING CONCRETE PAD 6
EXISTING CONCRETE PAD 7	EXISTING CONCRETE PAD 7
EXISTING CONCRETE PAD 8	EXISTING CONCRETE PAD 8
EXISTING CONCRETE PAD 9	EXISTING CONCRETE PAD 9
EXISTING CONCRETE PAD 10	EXISTING CONCRETE PAD 10
EXISTING CONCRETE PAD 11	EXISTING CONCRETE PAD 11
EXISTING CONCRETE PAD 12	EXISTING CONCRETE PAD 12
EXISTING CONCRETE PAD 13	EXISTING CONCRETE PAD 13
EXISTING CONCRETE PAD 14	EXISTING CONCRETE PAD 14
EXISTING CONCRETE PAD 15	EXISTING CONCRETE PAD 15
EXISTING CONCRETE PAD 16	EXISTING CONCRETE PAD 16
EXISTING CONCRETE PAD 17	EXISTING CONCRETE PAD 17
EXISTING CONCRETE PAD 18	EXISTING CONCRETE PAD 18
EXISTING CONCRETE PAD 19	EXISTING CONCRETE PAD 19
EXISTING CONCRETE PAD 20	EXISTING CONCRETE PAD 20
EXISTING CONCRETE PAD 21	EXISTING CONCRETE PAD 21
EXISTING CONCRETE PAD 22	EXISTING CONCRETE PAD 22
EXISTING CONCRETE PAD 23	EXISTING CONCRETE PAD 23
EXISTING CONCRETE PAD 24	EXISTING CONCRETE PAD 24
EXISTING CONCRETE PAD 25	EXISTING CONCRETE PAD 25
EXISTING CONCRETE PAD 26	EXISTING CONCRETE PAD 26
EXISTING CONCRETE PAD 27	EXISTING CONCRETE PAD 27
EXISTING CONCRETE PAD 28	EXISTING CONCRETE PAD 28
EXISTING CONCRETE PAD 29	EXISTING CONCRETE PAD 29
EXISTING CONCRETE PAD 30	EXISTING CONCRETE PAD 30
EXISTING CONCRETE PAD 31	EXISTING CONCRETE PAD 31
EXISTING CONCRETE PAD 32	EXISTING CONCRETE PAD 32
EXISTING CONCRETE PAD 33	EXISTING CONCRETE PAD 33
EXISTING CONCRETE PAD 34	EXISTING CONCRETE PAD 34
EXISTING CONCRETE PAD 35	EXISTING CONCRETE PAD 35
EXISTING CONCRETE PAD 36	EXISTING CONCRETE PAD 36
EXISTING CONCRETE PAD 37	EXISTING CONCRETE PAD 37
EXISTING CONCRETE PAD 38	EXISTING CONCRETE PAD 38
EXISTING CONCRETE PAD 39	EXISTING CONCRETE PAD 39
EXISTING CONCRETE PAD 40	EXISTING CONCRETE PAD 40
EXISTING CONCRETE PAD 41	EXISTING CONCRETE PAD 41
EXISTING CONCRETE PAD 42	EXISTING CONCRETE PAD 42
EXISTING CONCRETE PAD 43	EXISTING CONCRETE PAD 43
EXISTING CONCRETE PAD 44	EXISTING CONCRETE PAD 44
EXISTING CONCRETE PAD 45	EXISTING CONCRETE PAD 45
EXISTING CONCRETE PAD 46	EXISTING CONCRETE PAD 46
EXISTING CONCRETE PAD 47	EXISTING CONCRETE PAD 47
EXISTING CONCRETE PAD 48	EXISTING CONCRETE PAD 48
EXISTING CONCRETE PAD 49	EXISTING CONCRETE PAD 49
EXISTING CONCRETE PAD 50	EXISTING CONCRETE PAD 50
EXISTING CONCRETE PAD 51	EXISTING CONCRETE PAD 51
EXISTING CONCRETE PAD 52	EXISTING CONCRETE PAD 52
EXISTING CONCRETE PAD 53	EXISTING CONCRETE PAD 53
EXISTING CONCRETE PAD 54	EXISTING CONCRETE PAD 54
EXISTING CONCRETE PAD 55	EXISTING CONCRETE PAD 55
EXISTING CONCRETE PAD 56	EXISTING CONCRETE PAD 56
EXISTING CONCRETE PAD 57	EXISTING CONCRETE PAD 57
EXISTING CONCRETE PAD 58	EXISTING CONCRETE PAD 58
EXISTING CONCRETE PAD 59	EXISTING CONCRETE PAD 59
EXISTING CONCRETE PAD 60	EXISTING CONCRETE PAD 60
EXISTING CONCRETE PAD 61	EXISTING CONCRETE PAD 61
EXISTING CONCRETE PAD 62	EXISTING CONCRETE PAD 62
EXISTING CONCRETE PAD 63	EXISTING CONCRETE PAD 63
EXISTING CONCRETE PAD 64	EXISTING CONCRETE PAD 64
EXISTING CONCRETE PAD 65	EXISTING CONCRETE PAD 65
EXISTING CONCRETE PAD 66	EXISTING CONCRETE PAD 66
EXISTING CONCRETE PAD 67	EXISTING CONCRETE PAD 67
EXISTING CONCRETE PAD 68	EXISTING CONCRETE PAD 68
EXISTING CONCRETE PAD 69	EXISTING CONCRETE PAD 69
EXISTING CONCRETE PAD 70	EXISTING CONCRETE PAD 70
EXISTING CONCRETE PAD 71	EXISTING CONCRETE PAD 71
EXISTING CONCRETE PAD 72	EXISTING CONCRETE PAD 72
EXISTING CONCRETE PAD 73	EXISTING CONCRETE PAD 73
EXISTING CONCRETE PAD 74	EXISTING CONCRETE PAD 74
EXISTING CONCRETE PAD 75	EXISTING CONCRETE PAD 75
EXISTING CONCRETE PAD 76	EXISTING CONCRETE PAD 76
EXISTING CONCRETE PAD 77	EXISTING CONCRETE PAD 77
EXISTING CONCRETE PAD 78	EXISTING CONCRETE PAD 78
EXISTING CONCRETE PAD 79	EXISTING CONCRETE PAD 79
EXISTING CONCRETE PAD 80	EXISTING CONCRETE PAD 80
EXISTING CONCRETE PAD 81	EXISTING CONCRETE PAD 81
EXISTING CONCRETE PAD 82	EXISTING CONCRETE PAD 82
EXISTING CONCRETE PAD 83	EXISTING CONCRETE PAD 83
EXISTING CONCRETE PAD 84	EXISTING CONCRETE PAD 84
EXISTING CONCRETE PAD 85	EXISTING CONCRETE PAD 85
EXISTING CONCRETE PAD 86	EXISTING CONCRETE PAD 86
EXISTING CONCRETE PAD 87	EXISTING CONCRETE PAD 87
EXISTING CONCRETE PAD 88	EXISTING CONCRETE PAD 88
EXISTING CONCRETE PAD 89	EXISTING CONCRETE PAD 89
EXISTING CONCRETE PAD 90	EXISTING CONCRETE PAD 90
EXISTING CONCRETE PAD 91	EXISTING CONCRETE PAD 91
EXISTING CONCRETE PAD 92	EXISTING CONCRETE PAD 92
EXISTING CONCRETE PAD 93	EXISTING CONCRETE PAD 93
EXISTING CONCRETE PAD 94	EXISTING CONCRETE PAD 94
EXISTING CONCRETE PAD 95	EXISTING CONCRETE PAD 95
EXISTING CONCRETE PAD 96	EXISTING CONCRETE PAD 96
EXISTING CONCRETE PAD 97	EXISTING CONCRETE PAD 97
EXISTING CONCRETE PAD 98	EXISTING CONCRETE PAD 98
EXISTING CONCRETE PAD 99	EXISTING CONCRETE PAD 99
EXISTING CONCRETE PAD 100	EXISTING CONCRETE PAD 100

DATE	
OWNER	
PLAN APPROVAL	

1A  
SHEET NO.  
DATE  
OWNER  
PLAN APPROVAL

Area Analysis Plan

Submit Set

1000 N. Belmont Dr. #102 S.F. CA 94116  
Tel: (415) 255-1533  
D. Scott Hall Designers

1001 N. Coast Pine Ste 2000, CA 90705  
(415) 528-7715  
Lisa & Scott Harris  
A Harris Residential

1001 N. Coast Pine Ste 2000, CA 90705  
(415) 528-7715  
Lisa & Scott Harris  
A Harris Residential

1001 N. Coast Pine Ste 2000, CA 90705  
(415) 528-7715  
Lisa & Scott Harris  
A Harris Residential





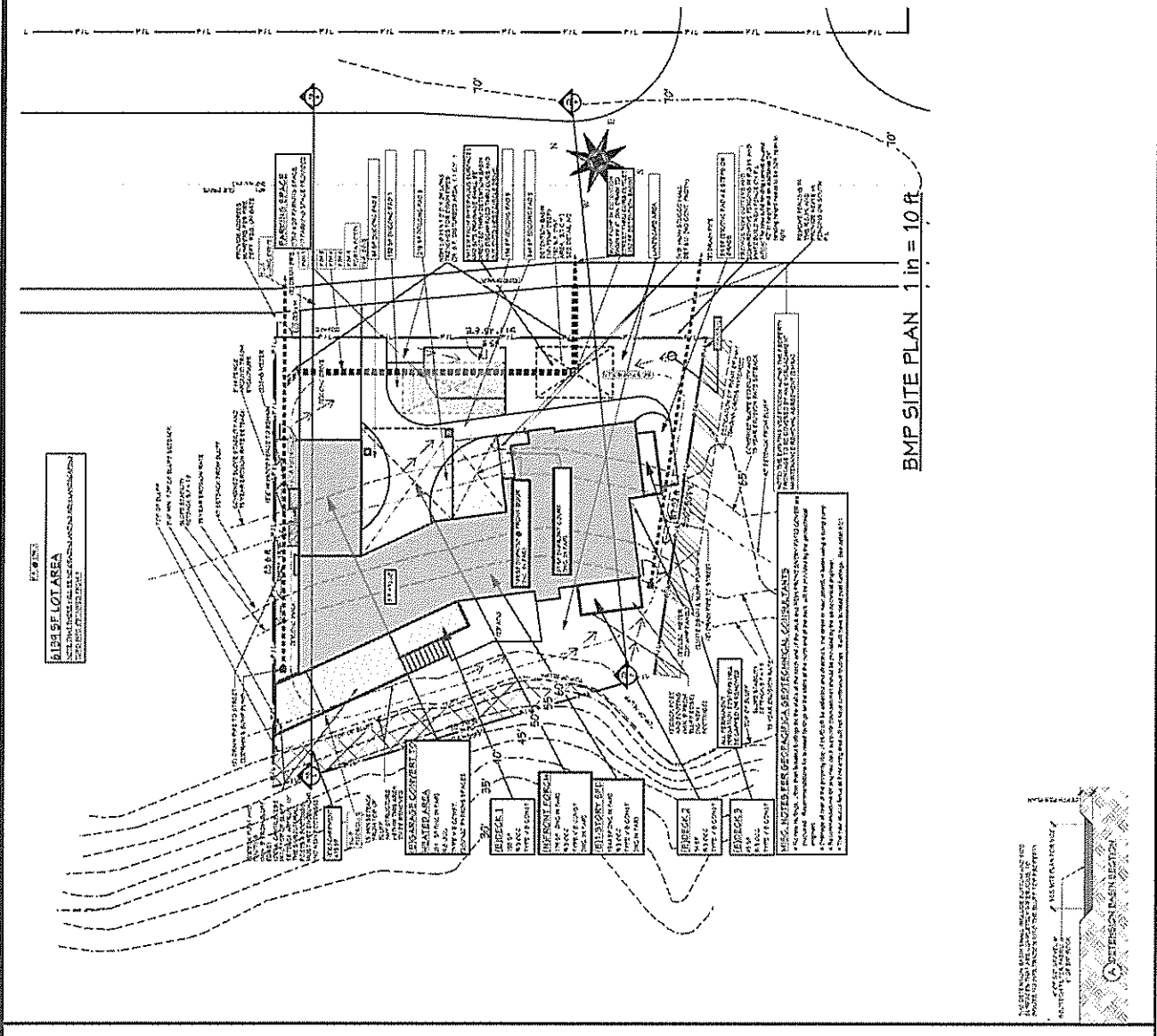
**STORMWATER POLLUTION CONTROL BMP NOTES**

**GENERAL REMARKS:** All BMPs shall be constructed in accordance with the City of Solana Beach Stormwater Pollution Control Manual, 2011 Edition, and all applicable local, state and federal regulations. BMPs shall be designed to meet the City of Solana Beach Stormwater Pollution Control Manual, 2011 Edition, and all applicable local, state and federal regulations. BMPs shall be designed to meet the City of Solana Beach Stormwater Pollution Control Manual, 2011 Edition, and all applicable local, state and federal regulations.

**DESIGN NOTES:** All BMPs shall be designed in accordance with the City of Solana Beach Stormwater Pollution Control Manual, 2011 Edition, and all applicable local, state and federal regulations. BMPs shall be designed to meet the City of Solana Beach Stormwater Pollution Control Manual, 2011 Edition, and all applicable local, state and federal regulations.

**CONSTRUCTION NOTES:** All BMPs shall be constructed in accordance with the City of Solana Beach Stormwater Pollution Control Manual, 2011 Edition, and all applicable local, state and federal regulations. BMPs shall be designed to meet the City of Solana Beach Stormwater Pollution Control Manual, 2011 Edition, and all applicable local, state and federal regulations.

**OPERATION AND MAINTENANCE NOTES:** All BMPs shall be operated and maintained in accordance with the City of Solana Beach Stormwater Pollution Control Manual, 2011 Edition, and all applicable local, state and federal regulations. BMPs shall be designed to meet the City of Solana Beach Stormwater Pollution Control Manual, 2011 Edition, and all applicable local, state and federal regulations.



**BMP LEGEND**

- 160000: [Symbol] STORAGE BASIN
- 160100: [Symbol] FLOW CONTROL STRUCTURE
- 160200: [Symbol] FILTER
- 160300: [Symbol] STORAGE TANK
- 160400: [Symbol] STORAGE TANK
- 160500: [Symbol] STORAGE TANK
- 160600: [Symbol] STORAGE TANK
- 160700: [Symbol] STORAGE TANK
- 160800: [Symbol] STORAGE TANK
- 160900: [Symbol] STORAGE TANK
- 161000: [Symbol] STORAGE TANK
- 161100: [Symbol] STORAGE TANK
- 161200: [Symbol] STORAGE TANK
- 161300: [Symbol] STORAGE TANK
- 161400: [Symbol] STORAGE TANK
- 161500: [Symbol] STORAGE TANK
- 161600: [Symbol] STORAGE TANK
- 161700: [Symbol] STORAGE TANK
- 161800: [Symbol] STORAGE TANK
- 161900: [Symbol] STORAGE TANK
- 162000: [Symbol] STORAGE TANK
- 162100: [Symbol] STORAGE TANK
- 162200: [Symbol] STORAGE TANK
- 162300: [Symbol] STORAGE TANK
- 162400: [Symbol] STORAGE TANK
- 162500: [Symbol] STORAGE TANK
- 162600: [Symbol] STORAGE TANK
- 162700: [Symbol] STORAGE TANK
- 162800: [Symbol] STORAGE TANK
- 162900: [Symbol] STORAGE TANK
- 163000: [Symbol] STORAGE TANK
- 163100: [Symbol] STORAGE TANK
- 163200: [Symbol] STORAGE TANK
- 163300: [Symbol] STORAGE TANK
- 163400: [Symbol] STORAGE TANK
- 163500: [Symbol] STORAGE TANK
- 163600: [Symbol] STORAGE TANK
- 163700: [Symbol] STORAGE TANK
- 163800: [Symbol] STORAGE TANK
- 163900: [Symbol] STORAGE TANK
- 164000: [Symbol] STORAGE TANK
- 164100: [Symbol] STORAGE TANK
- 164200: [Symbol] STORAGE TANK
- 164300: [Symbol] STORAGE TANK
- 164400: [Symbol] STORAGE TANK
- 164500: [Symbol] STORAGE TANK
- 164600: [Symbol] STORAGE TANK
- 164700: [Symbol] STORAGE TANK
- 164800: [Symbol] STORAGE TANK
- 164900: [Symbol] STORAGE TANK
- 165000: [Symbol] STORAGE TANK
- 165100: [Symbol] STORAGE TANK
- 165200: [Symbol] STORAGE TANK
- 165300: [Symbol] STORAGE TANK
- 165400: [Symbol] STORAGE TANK
- 165500: [Symbol] STORAGE TANK
- 165600: [Symbol] STORAGE TANK
- 165700: [Symbol] STORAGE TANK
- 165800: [Symbol] STORAGE TANK
- 165900: [Symbol] STORAGE TANK
- 166000: [Symbol] STORAGE TANK
- 166100: [Symbol] STORAGE TANK
- 166200: [Symbol] STORAGE TANK
- 166300: [Symbol] STORAGE TANK
- 166400: [Symbol] STORAGE TANK
- 166500: [Symbol] STORAGE TANK
- 166600: [Symbol] STORAGE TANK
- 166700: [Symbol] STORAGE TANK
- 166800: [Symbol] STORAGE TANK
- 166900: [Symbol] STORAGE TANK
- 167000: [Symbol] STORAGE TANK
- 167100: [Symbol] STORAGE TANK
- 167200: [Symbol] STORAGE TANK
- 167300: [Symbol] STORAGE TANK
- 167400: [Symbol] STORAGE TANK
- 167500: [Symbol] STORAGE TANK
- 167600: [Symbol] STORAGE TANK
- 167700: [Symbol] STORAGE TANK
- 167800: [Symbol] STORAGE TANK
- 167900: [Symbol] STORAGE TANK
- 168000: [Symbol] STORAGE TANK
- 168100: [Symbol] STORAGE TANK
- 168200: [Symbol] STORAGE TANK
- 168300: [Symbol] STORAGE TANK
- 168400: [Symbol] STORAGE TANK
- 168500: [Symbol] STORAGE TANK
- 168600: [Symbol] STORAGE TANK
- 168700: [Symbol] STORAGE TANK
- 168800: [Symbol] STORAGE TANK
- 168900: [Symbol] STORAGE TANK
- 169000: [Symbol] STORAGE TANK
- 169100: [Symbol] STORAGE TANK
- 169200: [Symbol] STORAGE TANK
- 169300: [Symbol] STORAGE TANK
- 169400: [Symbol] STORAGE TANK
- 169500: [Symbol] STORAGE TANK
- 169600: [Symbol] STORAGE TANK
- 169700: [Symbol] STORAGE TANK
- 169800: [Symbol] STORAGE TANK
- 169900: [Symbol] STORAGE TANK
- 170000: [Symbol] STORAGE TANK

**PLANS APPROVAL**

OWNER: [Name]

DATE: [Date]

DATE: [Date]

DATE: [Date]

**CONTRACTOR TO VERIFY ALL CONDITIONS PRIOR TO BEGINNING CONSTRUCTION AND NOTIFY DESIGNER IMMEDIATELY IN WRITING OF ANY DISCREPANCIES WITH THESE PLANS.**

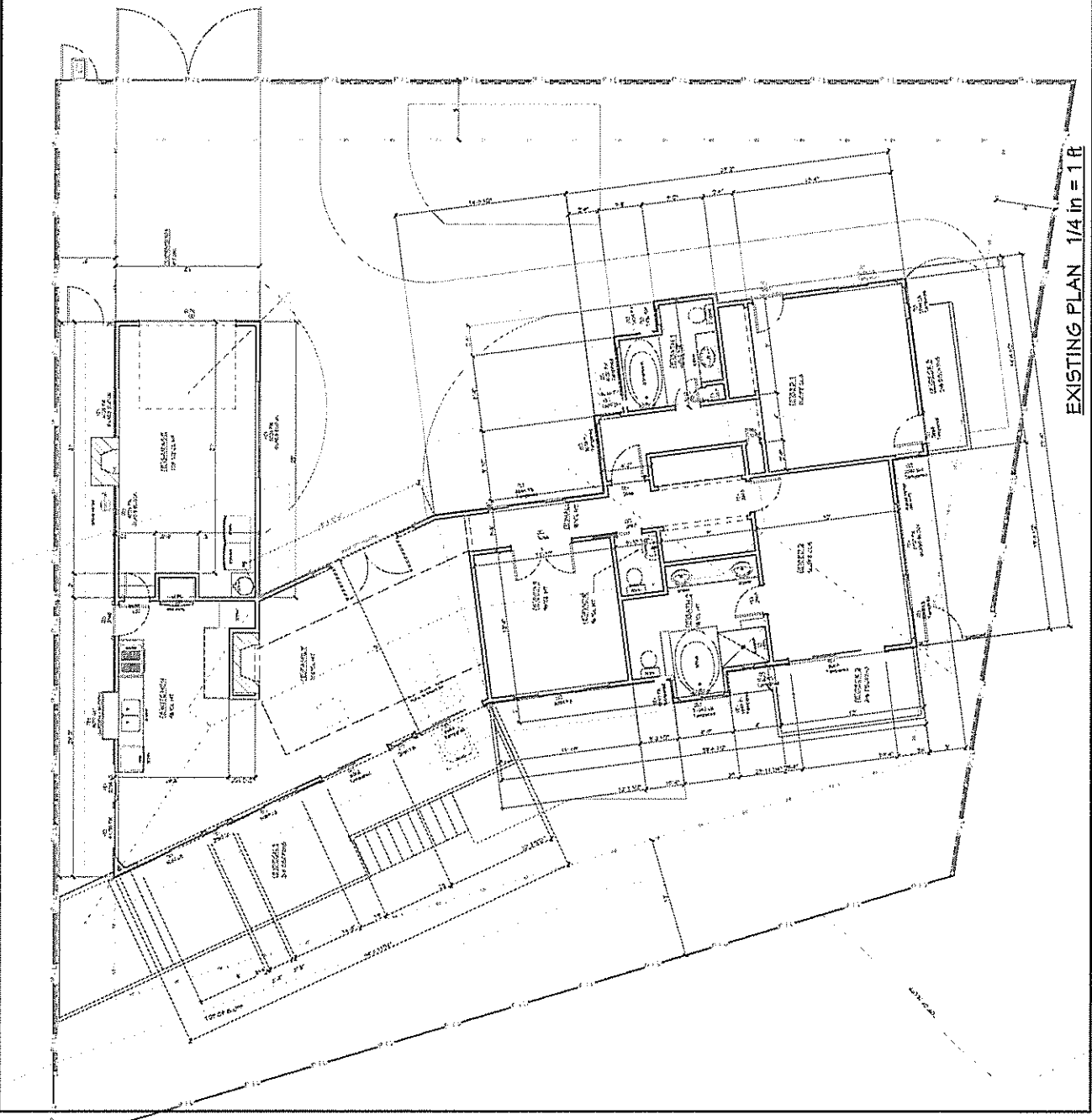
**Submit Set**

**LSB & Scott Harris**  
601 N. Olive Drive, Ste 200, Solana Beach, CA 92083  
(619) 752-7773

**DYAK**  
DESIGN BUILD

**D. Scott Harris Designers**  
1800 N. Harbor Dr., Suite 200, Solana Beach, CA 92083  
(619) 752-7773

**BMP Plan**  
Sheet No. 2



EXISTING PLAN 1/4 in = 1 ft

DATE	DATE
OWNER	DATE
OWNER	DATE
OWNER	DATE

PLAN APPROVAL

WALL LEGEND  
 EXISTING WALL  
 NEW WALL  
 REMOVED WALL

SHEET NO. 3  
 SHEET TOTAL 3  
 DATE

CONTRACTOR TO VERIFY ALL CONDITIONS PRIOR TO BEGINNING CONSTRUCTION AND CONSULT WITH DESIGNER IF THERE ARE ANY INCONSISTENCIES WITH EXISTING CONDITIONS AND THE PLANS.  
 CONTRACT NO.

Lisa & Scott Harris  
 60175 Creek Drive, Ste 200, San Diego, CA 92121  
 (619) 224-1770  
 A FORM REQUIRED BY

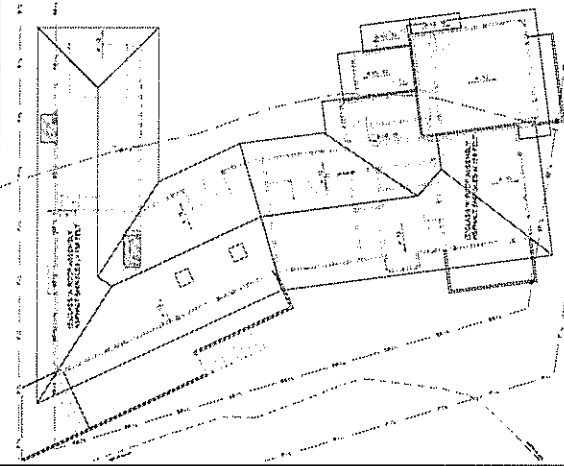
DYPK DESIGN BUILD  
 16937 W. Dennis Dr., #102, San Diego, CA 92127  
 Tel: (619) 550-1123  
 Plans prepared by

D. Scott Harris  
 16937 W. Dennis Dr., #102, San Diego, CA 92127  
 Tel: (619) 550-1123  
 Date: 2/17/15

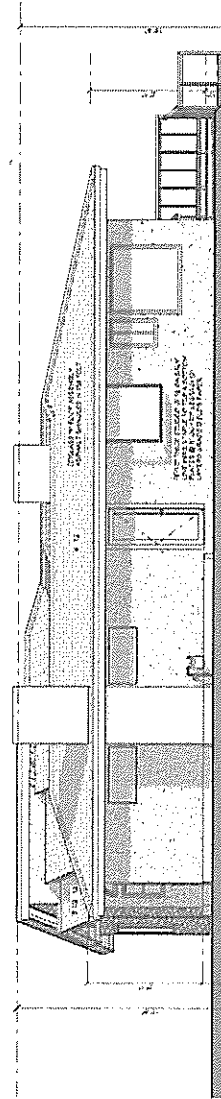
Submit Set

Exist. Plan

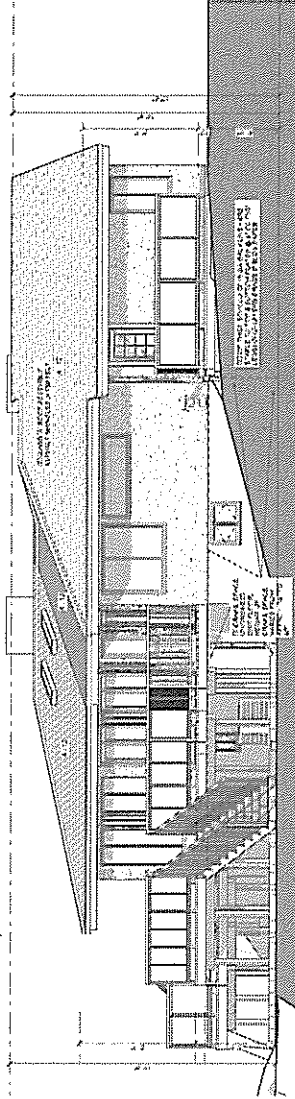
EXISTING ROOF PLAN 1/8 in = 1 ft



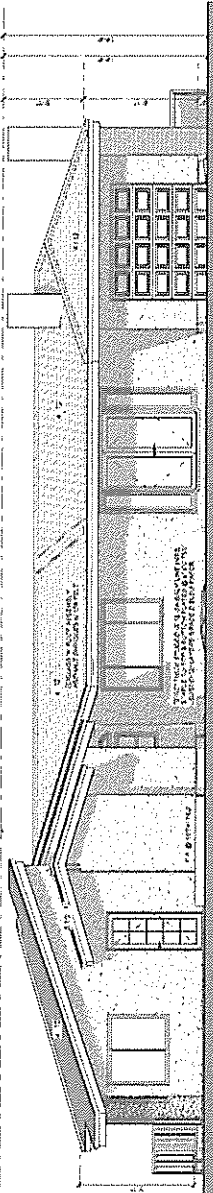
EXISTING RIGHT/NORTH 1/4 in = 1 ft



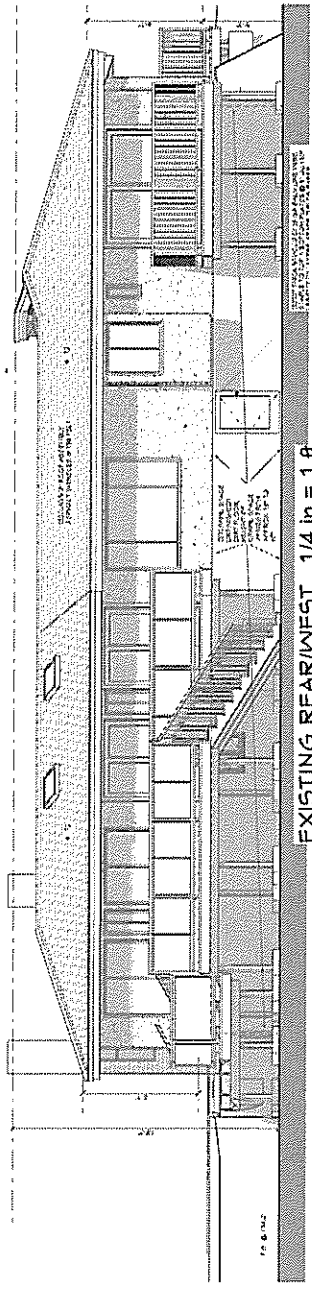
EXISTING LEFT/SOUTH 1/4 in = 1 ft



EXISTING FRONT/EAST 1/4 in = 1 ft



EXISTING REAR/WEST 1/4 in = 1 ft



DATE	DATE
OWNER	DATE
OWNER	DATE
OWNER	DATE

EXIST ELEV.	4
PROJECT NO.	2020-0000
DATE	04/20/20
SCALE	1/4" = 1'-0"
DATE	04/20/20
OWNER	1000 W. BERRY ST. #100
OWNER	LOS ANGELES, CA 90017

DATE	DATE
OWNER	DATE
OWNER	DATE
OWNER	DATE

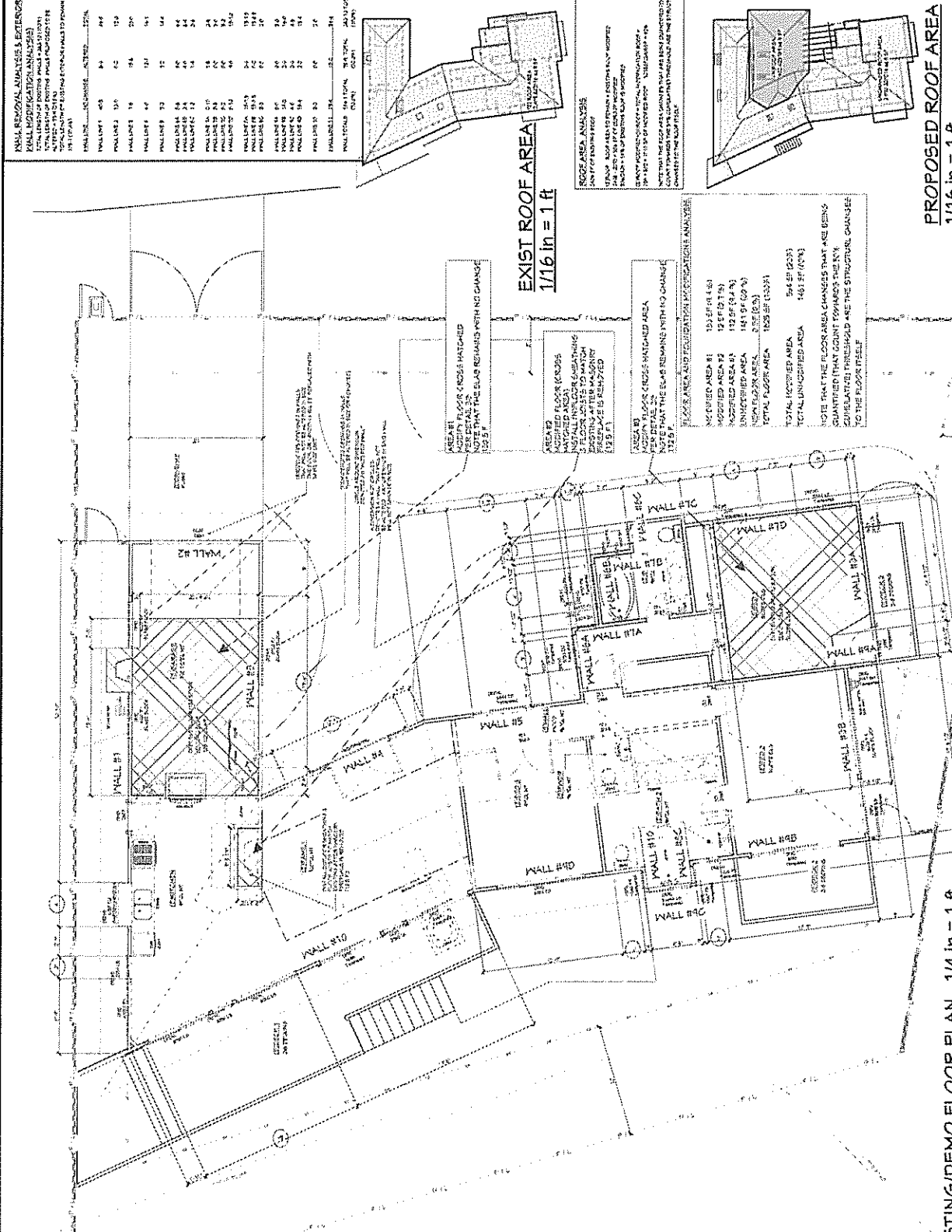
Submit Set

DYJAK DESIGN GROUP

D. Scott Hall Designers

REVISIONS	

CONTRACTOR TO FIELD VERIFY ALL CONDITIONS PRIOR TO BEGINNING CONSTRUCTION AND CONSULT WITH DESIGNER IF THERE ARE ANY INCONSISTENCIES WITH EXISTING CONDITIONS AND THE PLANS.

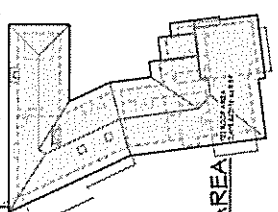


**WALL REMOVAL ANALYSIS & EXTENSIVE WALL INVESTIGATION ANALYSIS**

ALL EXISTING WALLS ARE 12" THICK UNLESS NOTED OTHERWISE. ALL EXISTING WALLS ARE CONCRETE UNLESS NOTED OTHERWISE.

ALL EXISTING WALLS ARE TO REMAIN UNLESS NOTED OTHERWISE.

WALL NO.	WALL TYPE	WALL THICKNESS	WALL AREA (SQ FT)	WALL PERIMETER (LINEAR FEET)
WALL #1	CONCRETE	12"	125	100
WALL #2	CONCRETE	12"	141	110
WALL #3	CONCRETE	12"	148	115
WALL #4	CONCRETE	12"	155	120
WALL #5	CONCRETE	12"	162	125
WALL #6	CONCRETE	12"	170	130
WALL #7	CONCRETE	12"	178	135
WALL #8	CONCRETE	12"	185	140
WALL #9	CONCRETE	12"	195	145
WALL #10	CONCRETE	12"	205	150
WALL #11	CONCRETE	12"	215	155
WALL #12	CONCRETE	12"	225	160
WALL #13	CONCRETE	12"	235	165
WALL #14	CONCRETE	12"	245	170
WALL #15	CONCRETE	12"	255	175
WALL #16	CONCRETE	12"	265	180
WALL #17	CONCRETE	12"	275	185
WALL #18	CONCRETE	12"	285	190
WALL #19	CONCRETE	12"	295	195
WALL #20	CONCRETE	12"	305	200
TOTAL			3050	2400



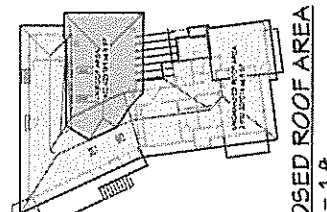
**EXISTING ROOF AREA**  
1/16 in = 1 ft

**ROOF AREA ANALYSIS**

EXISTING ROOF AREA IS 148,000 SQ FT. THIS INCLUDES ALL ROOF AREAS INCLUDING ROOF TERRACES AND ROOF DECKS.

EXISTING ROOF AREA IS 148,000 SQ FT. THIS INCLUDES ALL ROOF AREAS INCLUDING ROOF TERRACES AND ROOF DECKS.

EXISTING ROOF AREA IS 148,000 SQ FT. THIS INCLUDES ALL ROOF AREAS INCLUDING ROOF TERRACES AND ROOF DECKS.



**PROPOSED ROOF AREA**  
1/16 in = 1 ft

**FLOOR AREA AND FOUNDATION INVESTIGATION ANALYSIS**

EXISTING FLOOR AREA IS 148,000 SQ FT. THIS INCLUDES ALL FLOOR AREAS INCLUDING ROOF TERRACES AND ROOF DECKS.

EXISTING FLOOR AREA IS 148,000 SQ FT. THIS INCLUDES ALL FLOOR AREAS INCLUDING ROOF TERRACES AND ROOF DECKS.

EXISTING FLOOR AREA IS 148,000 SQ FT. THIS INCLUDES ALL FLOOR AREAS INCLUDING ROOF TERRACES AND ROOF DECKS.

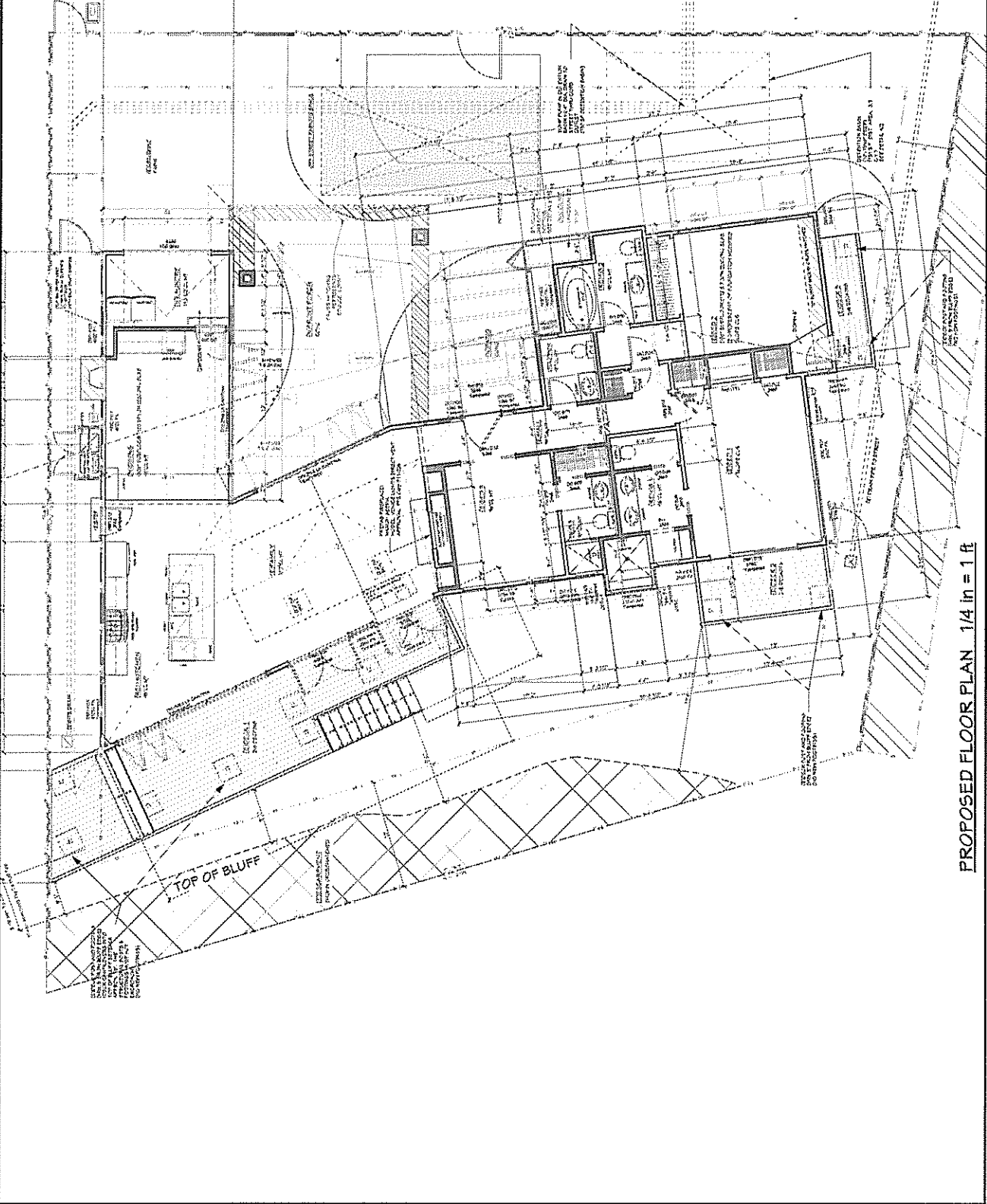
**EXISTING DEMO FLOOR PLAN** 1/4 in = 1 ft  
**ANALYSIS OF REMOVED WALLS**

**REMOVE AREA #1** 125 SF (4.61)  
**REMOVE AREA #2** 141 SF (5.15)  
**REMOVE AREA #3** 148 SF (5.37)  
**REMOVE AREA #4** 155 SF (5.67)  
**REMOVE AREA #5** 162 SF (5.95)  
**REMOVE AREA #6** 170 SF (6.26)  
**REMOVE AREA #7** 178 SF (6.54)  
**REMOVE AREA #8** 185 SF (6.82)  
**REMOVE AREA #9** 195 SF (7.15)  
**REMOVE AREA #10** 205 SF (7.47)  
**REMOVE AREA #11** 215 SF (7.80)  
**REMOVE AREA #12** 225 SF (8.12)  
**REMOVE AREA #13** 235 SF (8.45)  
**REMOVE AREA #14** 245 SF (8.77)  
**REMOVE AREA #15** 255 SF (9.10)  
**REMOVE AREA #16** 265 SF (9.42)  
**REMOVE AREA #17** 275 SF (9.75)  
**REMOVE AREA #18** 285 SF (10.07)  
**REMOVE AREA #19** 295 SF (10.40)  
**REMOVE AREA #20** 305 SF (10.72)  
**TOTAL REMOVE AREA** 3050 SF (110.00)

**TOTAL UNCHANGED AREA** 148,000 SF (5380.00)

NOTE THAT THE FLOOR AREA CHANGES THAT ARE BEING QUANTIFIED (THAT GO OUT TOWARDS THE R.V. CORRELATES) THROUGHOUT ARE THE STRUCTURAL CHANGES TO THE FLOOR ITSELF.

PROPOSED FLOOR PLAN 1/4 in = 1 ft



**PLAN APPROVAL**

DATE \_\_\_\_\_ DATE \_\_\_\_\_  
 OWNER \_\_\_\_\_ OWNER \_\_\_\_\_

**LEGEND**

EXCISED LAND  
 EXISTING PAVEMENT  
 EXISTING DRIVE  
 EXISTING SIDEWALK  
 EXISTING CURB  
 EXISTING FENCE  
 EXISTING UTILITY

**PROPOSED**

PROPOSED DRIVE  
 PROPOSED SIDEWALK  
 PROPOSED CURB  
 PROPOSED FENCE  
 PROPOSED UTILITY

**FINISHES**

CONCRETE  
 CERAMIC TILE  
 CARPET  
 PAINT  
 GYP. BOARD  
 PLASTER  
 BRICK  
 BLOCK  
 STUCCO  
 GLASS  
 METAL  
 WOOD

**NOTES**

1. ALL DIMENSIONS ARE IN FEET AND INCHES UNLESS OTHERWISE NOTED.

2. ALL FINISHES ARE TO BE AS SHOWN ON THE FINISH SCHEDULE.

3. ALL MATERIALS ARE TO BE OF THE BEST QUALITY AVAILABLE.

4. ALL WORK IS TO BE DONE IN ACCORDANCE WITH THE LATEST EDITIONS OF THE BUILDING CODES AND SPECIFICATIONS.

5. ALL UTILITIES ARE TO BE DEPTH TESTED AND RECORDED PRIOR TO CONSTRUCTION.

6. ALL EXISTING UTILITIES ARE TO BE PROTECTED AND NOT TO BE MOVED OR DELETED UNLESS OTHERWISE NOTED.

7. ALL EXISTING UTILITIES ARE TO BE DEPTH TESTED AND RECORDED PRIOR TO CONSTRUCTION.

8. ALL EXISTING UTILITIES ARE TO BE PROTECTED AND NOT TO BE MOVED OR DELETED UNLESS OTHERWISE NOTED.

9. ALL EXISTING UTILITIES ARE TO BE DEPTH TESTED AND RECORDED PRIOR TO CONSTRUCTION.

10. ALL EXISTING UTILITIES ARE TO BE PROTECTED AND NOT TO BE MOVED OR DELETED UNLESS OTHERWISE NOTED.

**Proposed Plan**

PROJECT NO. 6

DATE 12/15/2010

OWNER Lisa & Scott Harris

DESIGNER D. Scott Harris

15037 N. Dimmock Dr., #102, S.D., CA, 95131

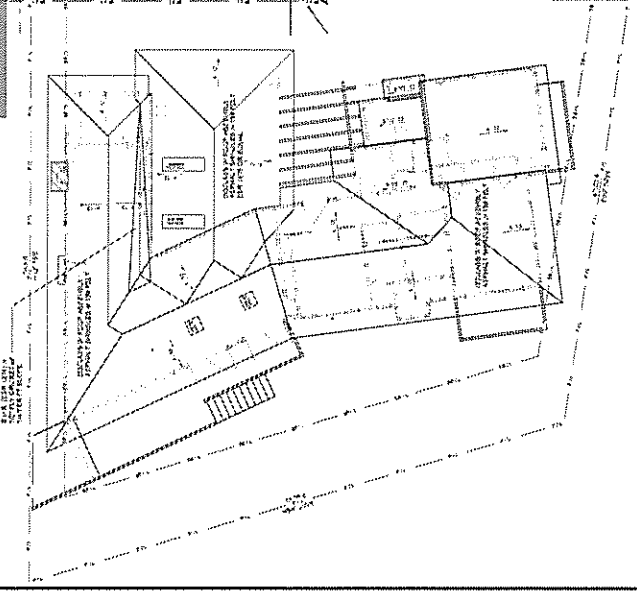
TEL: (415) 552-1533

PLM 27113

**Submit Set**

Proposed Plan

PROPOSED ROOF PLAN 1/8 in = 1 ft

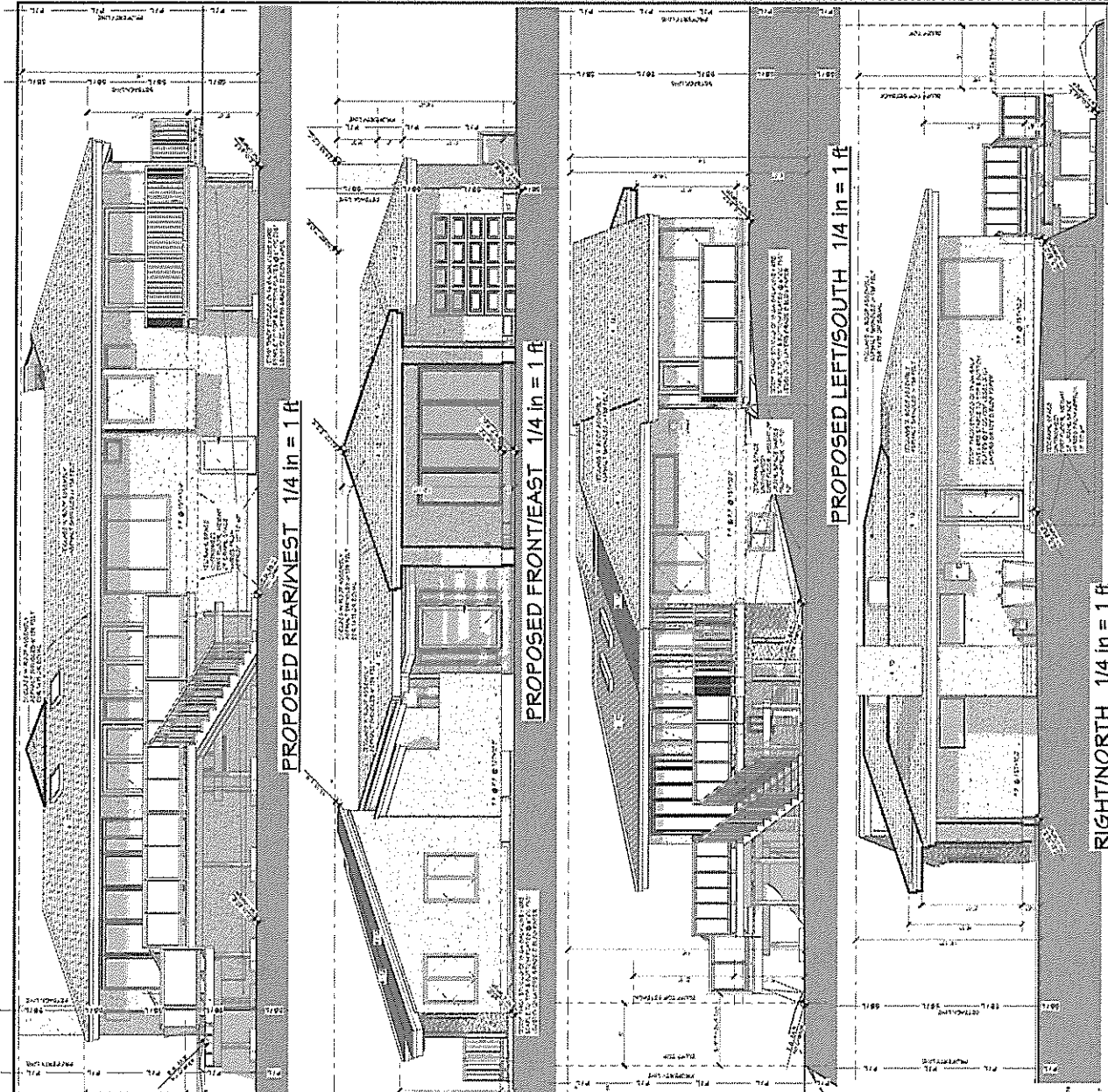


RIGHT/NORTH 1/4 in = 1 ft

PROPOSED LEFT/SOUTH 1/4 in = 1 ft

PROPOSED FRONT/EAST 1/4 in = 1 ft

PROPOSED REAR/WEST 1/4 in = 1 ft



DATE	DATE
PLAN APPROVAL	
OWNER	
DESIGNER	

Proposed Elev.

Proposed Elev.

CONTRACTORS TO VERIFY ALL CONDITIONS PRIOR TO BEGINNING CONSTRUCTION AND NOTIFY DESIGNER IF THERE ARE ANY INCONSISTENCIES WITH EXISTING CONDITIONS AND THE PLAN.

THIS PLAN IS THE PROPERTY OF THE DESIGNER AND IS NOT TO BE REPRODUCED OR COPIED IN ANY MANNER WITHOUT THE WRITTEN PERMISSION OF THE DESIGNER.

DATE: 08/11/2011

PROJECT NO: 11-001

DESIGNER: Lisa & Scott Harris (619) 223-7715, 6011 Y Circle Drive, Dana Point, CA 92629

DESIGNER: D. Scott Hall Designers, 1630 W. Bonita Dr., #102, San Diego, CA 92121, Tel: (619) 200-1620

DESIGNER: DYAK DESIGN BUILD

Submit Set

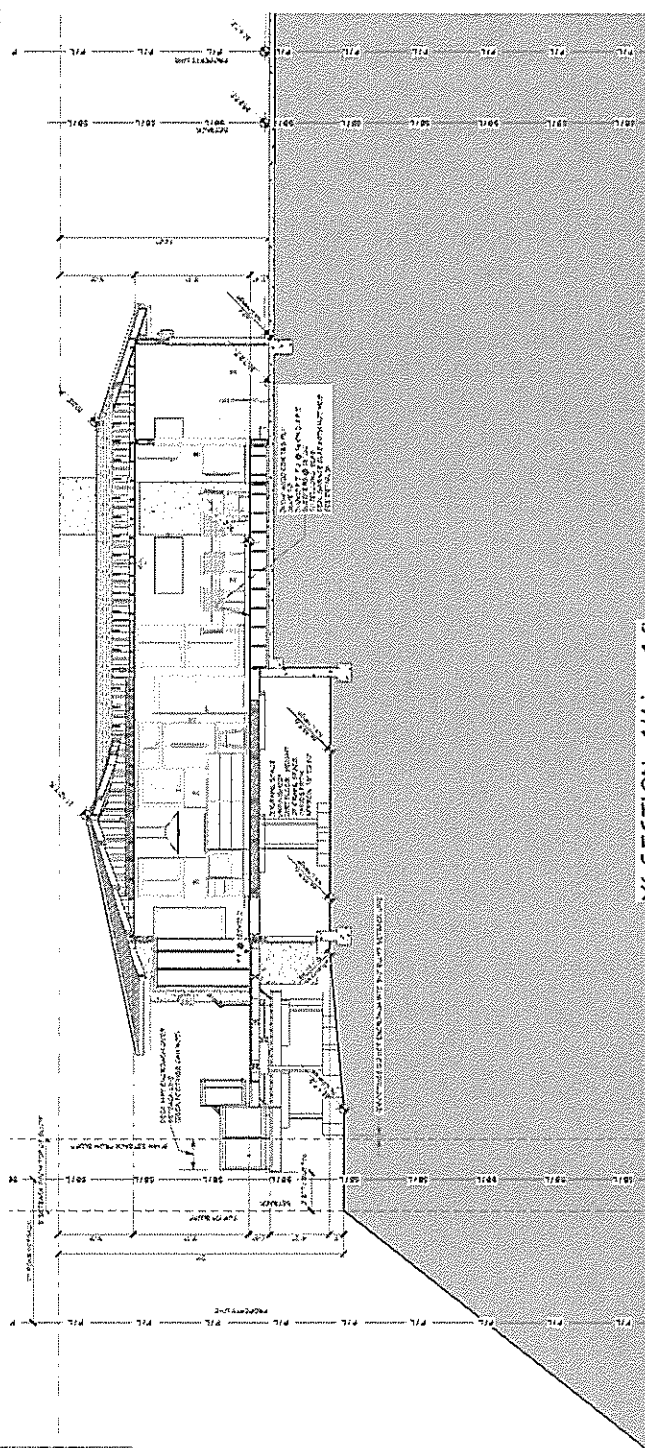


Sections

SECTION NO.	6
DATE	
OWNER	
DATE	

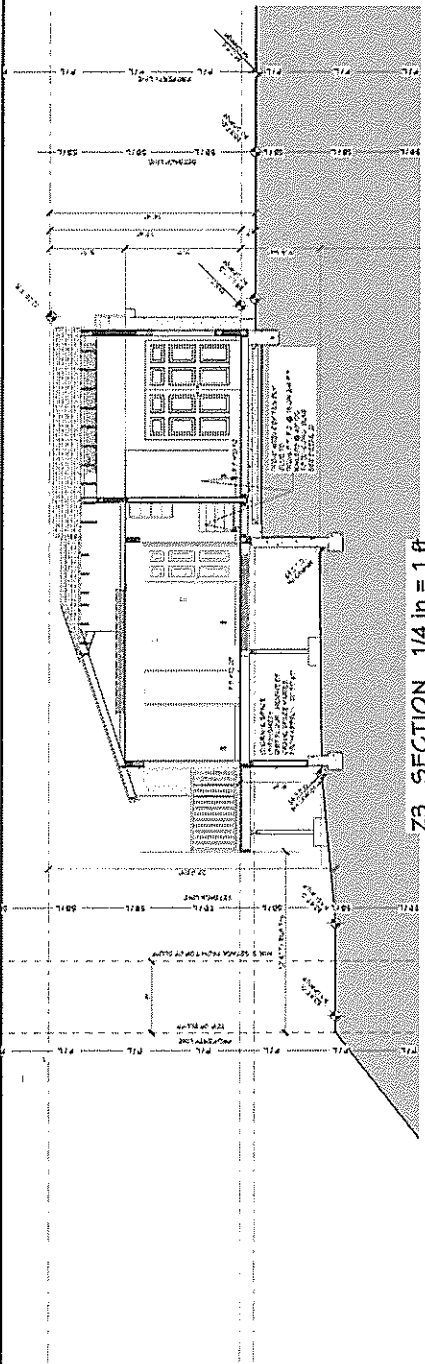
PLAN APPROVAL

DATE  
OWNER

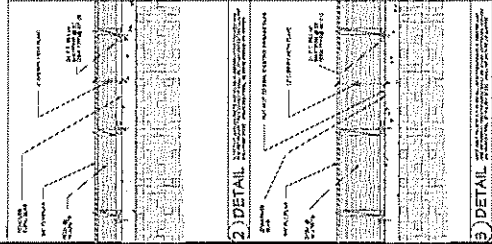


X6 SECTION 1/4 in = 1 ft

EXPLANATION OF NOTATION:  
 1. ALL DIMENSIONS ARE TO FACE UNLESS OTHERWISE NOTED.  
 2. ALL DIMENSIONS ARE TO FACE UNLESS OTHERWISE NOTED.  
 3. ALL DIMENSIONS ARE TO FACE UNLESS OTHERWISE NOTED.  
 4. ALL DIMENSIONS ARE TO FACE UNLESS OTHERWISE NOTED.  
 5. ALL DIMENSIONS ARE TO FACE UNLESS OTHERWISE NOTED.  
 6. ALL DIMENSIONS ARE TO FACE UNLESS OTHERWISE NOTED.



Z3 SECTION 1/4 in = 1 ft



CONTRACTOR TO VERIFY ALL CONDITIONS FROM TO BEGINNING CONSTRUCTION AND CONSULT WITH DESIGNER IF THERE ARE ANY INCONSISTENCIES WITH EXISTING CONDITIONS AND THE PLAN.

**LS&S**  
 Lisa & Scott Harris  
 601 N. Olive Drive, Santa Beach, CA 92775  
 (949) 237-7770

**DDP**  
 DESIGN BUILD  
 D Scott Hall Designers  
 15055 N. Diamond Dr., Suite 901, CA 92721  
 (949) 452-1633

Submit Set

DATE: 08/27/19



# Geotechnical Exploration, Inc.

SOIL AND FOUNDATION ENGINEERING • GROUNDWATER • ENGINEERING GEOLOGY

11 August 2017

Mr. Scott Harris  
P.O. Box 1389  
Rancho Santa Fe, CA 92067

**Job No. 11-10035**

Subject: **Response to Geotechnical Reviewer Comments**  
Harris Residence  
601 W. Circle Drive  
Solana Beach, California

RECEIVED

AUG 16 2017

Planning-Comm Dev Dept  
City of Solana Beach

Dear Mr. Harris:

As requested, we have reviewed the document entitled "Geotechnical Review of Proposed Project, Scott and Linda Harris, 601 W. Circle Drive, Solana Beach, CA 92075," by Geopacifica Geotechnical Consultant, dated June 29, 2017, regarding the proposed project at the subject project.

The reviewer indicates that, among other listed documents, our "Plan Review and Updated Geotechnical Investigation, Harris Residence, 601 W. Circle Drive, Solana Beach, CA," dated May 24, 2017, and the "Geotechnical Investigation and Bluff Stability Study, 601 West Circle Drive, Solana Beach, California," by TerraCosta Consulting Group, dated July 8, 2013, was reviewed. It is the reviewer's opinion that the reports do not address the requirements of the City of Solana Beach Municipal Code or the requirements of the City of Solana Beach LCP/LUP. Herein, we address the geotechnical comments.



### **REVIEWER'S COMMENTS AND REPLYS**

**First Comment:** *"In accordance with the requirements of the LCP/LUP, the Geologic Safety Factor Line (GSL) should be a combination of the determination of the 1.5 safety factor line and a cumulative erosion rate for 75 years. This line should be shown on a cross-section in the geotechnical report and on the building plans. The new geotechnical consultant, Geotechnical Exploration, will need to update the original geotechnical report by TerraCosta Consulting Group."*

**GEI Response:** We have included a revised geotechnical/geologic map and cross section that shows the Geologic Safety Factor Line (GSL) which is a combination of the 1.5 safety factor line and a cumulative erosion rate for 75 years. Our most recent Plan Review and Updated Geotechnical Investigation letter, dated May 24, 2017, confirms that the plans were found to be in general conformance with our original geotechnical report and the latest geotechnical report by TerraCosta Consulting Group, dated July 8, 2013. It should be noted that our report was attached as Appendix A of the TerraCosta report. We have reviewed and accept all findings and recommendations of the TerraCosta report.

**Second Comment:** *"I have not met onsite with the geotechnical consultant for the applicant to determine the top of bluff."*

**GEI Response:** On July 20, 2017, we met with the City's geotechnical consultant, Mr. James Knowlton, to confirm the top of bluff location. We were in agreement that the field conditions were consistent with the top of bluff shown in the geotechnical report.



Third Comment: *"No new footings, other than isolated footings for the deck, will be allowed. This is in anticipation of the new Geologic Safety Factor Line (GSL)."*

**GEI Response:** No new footings, other than isolated footings for the stairs at the north end of the deck and front entry patio cover, are proposed.

Fourth Comment: *"The 75-year erosion rate will have to be recalculated to include sea level rise and any new information regarding erosion that may have come to light since the original geotechnical report."*

**GEI Response:** Based on our work at multiple bluff top locations between the Seaside parking lot and Tide Park, the subject property's basal bluff has exhibited greater resistance to basal recession than observed at other locations. Whereas a thin clay bed at wave attack height results in deep notching and cave formation to the south, the massively bedded Torrey Sandstone provides better protection below the subject property. We have monitored basal bluff notching in massively bedded Torrey Sandstone north of Stone Steps in the Leucadia area for over 20 years. We have recalculated the 75-year erosion rate based on current information for erosion that includes sea level rise, and we have concluded that there is no change in this area of Solana Beach. We have applied our measured erosion rate of 2.25 inches per year (or 0.1875 feet per year) to the subject property. It is our opinion that the 0.4 feet per year (or 30 feet in 75 years) erosion rate utilized by the City of Solana Beach is much too conservative when added to the 1.5 safety factor line. We have included here a revised bluff retreat based on recalculations using a 0.1875 feet per year rate or 14.06 feet in 75 years.



Fifth Comment: *"Drainage at the rear of the property (top of bluff) will have to be collected and directed to the street or new detention basin, most likely utilizing a sump pump."*

**GEI Response:** Based on our review of the updated plans, drainage at the site will be collected and directed to the street via a new detention basin utilizing a sump pump.

Sixth Comment: *"Please provide a detail of the leveling of existing floor slabs where described."*

**GEI Response:** We understand that the revised plans include a detail of the leveling of existing floor slabs. The slabs will not be modified. Wood floors will be build over the slabs in their current location.

Seventh Comment: *"Please provide a detail or specifications for the pre-fab fireplace."*

**GEI Response:** We understand that the revised plans include a detail for the pre-fab fireplace.

Eighth Comment: *"Was the garage slab, which is now being converted, connected to the existing footing and does it have a vapor barrier? Typically, garages are free floating and not connected to the perimeter footing and are not prepared (with sand/vapor barrier/sand/slab) like a house slab."*



**GEI Response:** We understand that the garage slab is not connected to the existing footing. A moisture barrier is proposed on top of the garage slab prior to installation of the wood flooring.

**Ninth Comment:** *"Recommendations for any new deck supports (foundations) should be provided by the geotechnical engineer."*

**GEI Response:** We have provided recommendations for the new deck foundations in our original geotechnical report (included as Appendix A of the TerraCosta report).

**Tenth Comment:** *"The proposed 5-foot high stucco wall is anticipated not to be allowed to have continuous footings."*

**GEI Response:** We understand that the proposed wall will be supported on isolated spread footings and not a continuous footing.

We hope that we have adequately answered the pertinent comments indicated by the City's geotechnical reviewer.

The findings and opinions presented herein have been made in accordance with generally accepted principles and practice in the field of geotechnical engineering within the County of San Diego. No warranty expressed or implied is made.



If you have any questions or comments please contact our office. Reference to our **Job No. 11-10035** will help expedite a response to your inquiry.

Respectfully submitted,

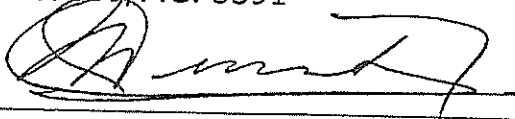
**GEOTECHNICAL EXPLORATION, INC.**



Leslie D. Reed, President  
C.E.G. 999/P.G. 3391



Jay K. Heiser  
Senior Project Geologist

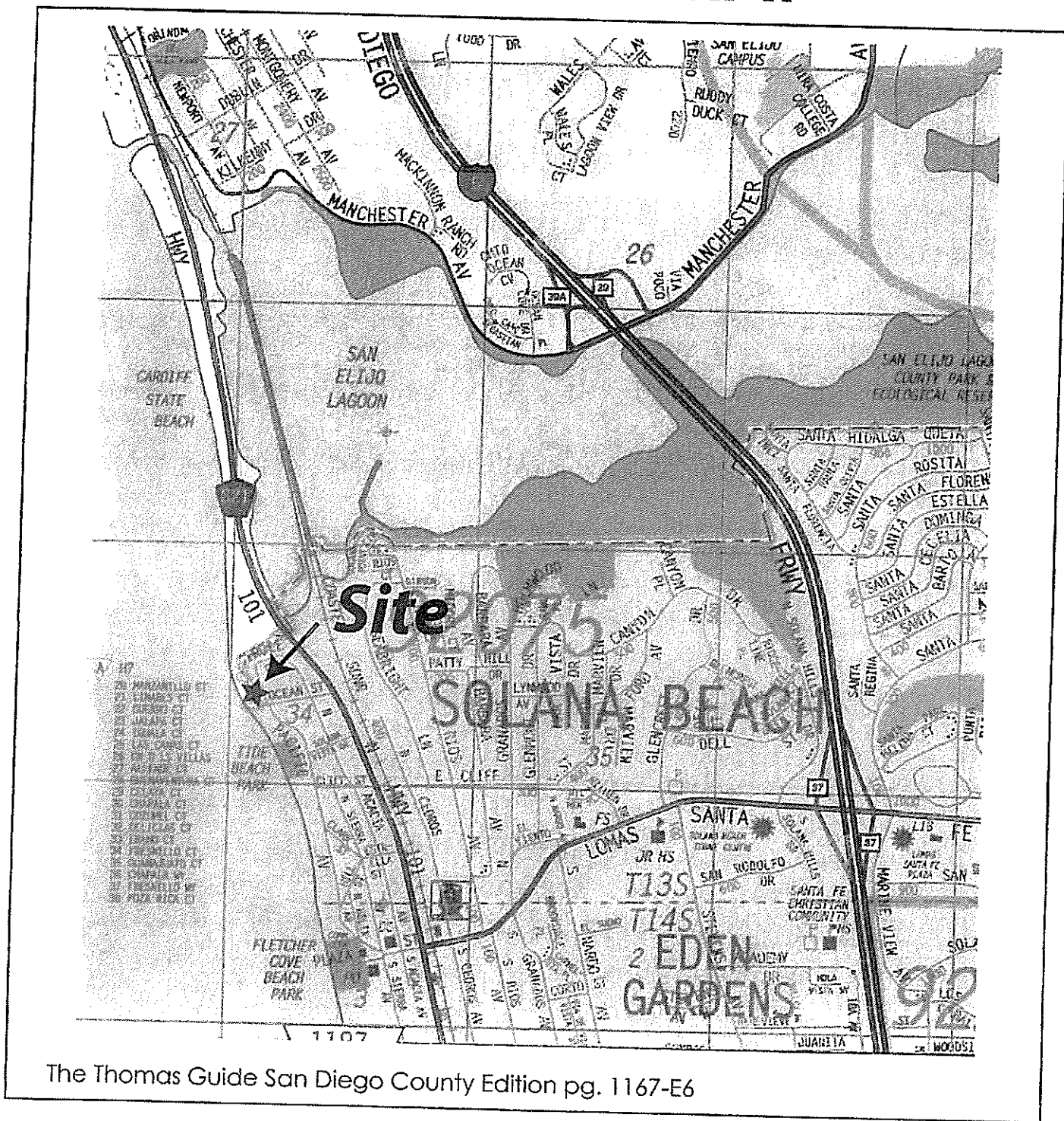


Jaime A. Cerros, P.E.  
R.C.E. 34422/G.E. 2007  
Senior Geotechnical Engineer

Enclosures: Revised Geotechnical/Geologic Map



# VICINITY MAP



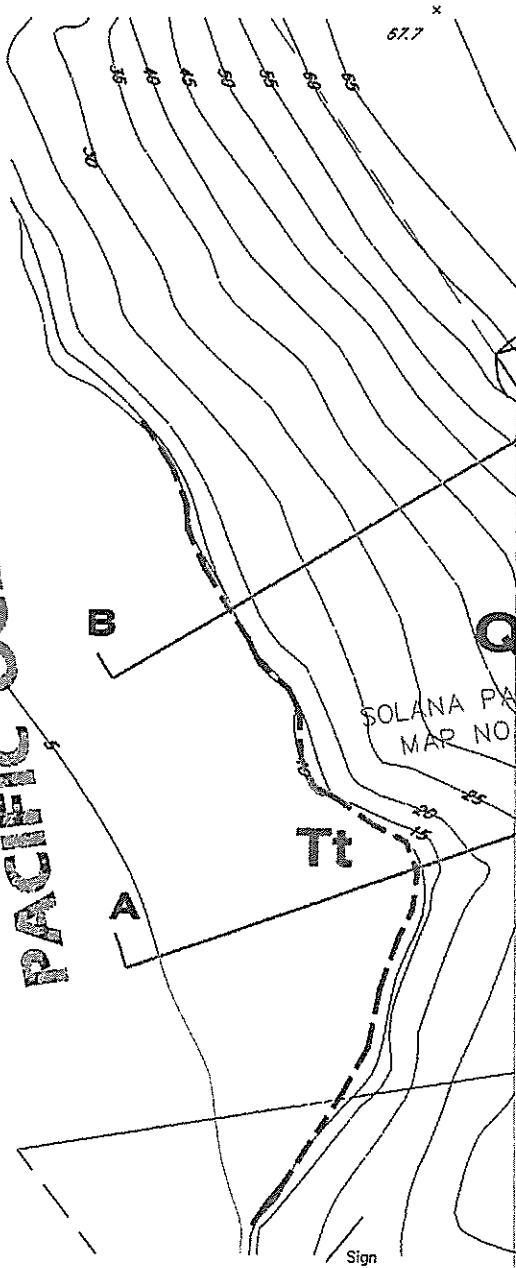
The Thomas Guide San Diego County Edition pg. 1167-E6

Harris Residence  
601 W. Circle Drive  
Solana Beach, CA.

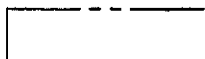

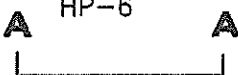


Figure No. 1  
Job No. 11-10035




PACIFIC OCEAN



### Legend

-  ASSUMED PROPERTY BOUNDARY
-  APPROXIMATE LOCATION OF EXPLORATORY HANDPIT
-  GEOLOGIC CROSS SECTION
- Qt** TERRACE DEPOSITS
- Tt** TORREY SANDSTONE
-  APPROXIMATE GEOLOGIC CONTACT
-  SLOPE STABILITY SETBACK  
SF = 1.5



 SAN-LO AERIAL SURVEYS  
4675 VIEWRIDGE AVE., SAN DIEGO, CA. 92123-1687 (858) 585-1024

JN: 13542 601 Circle Drive FLOWN: 5-10-11  
CONTOUR INTERVAL: 1' SHEET 1 OF 1



SCALE: 1" = 20'

## PLOT PLAN AND GEOLOGIC MAP

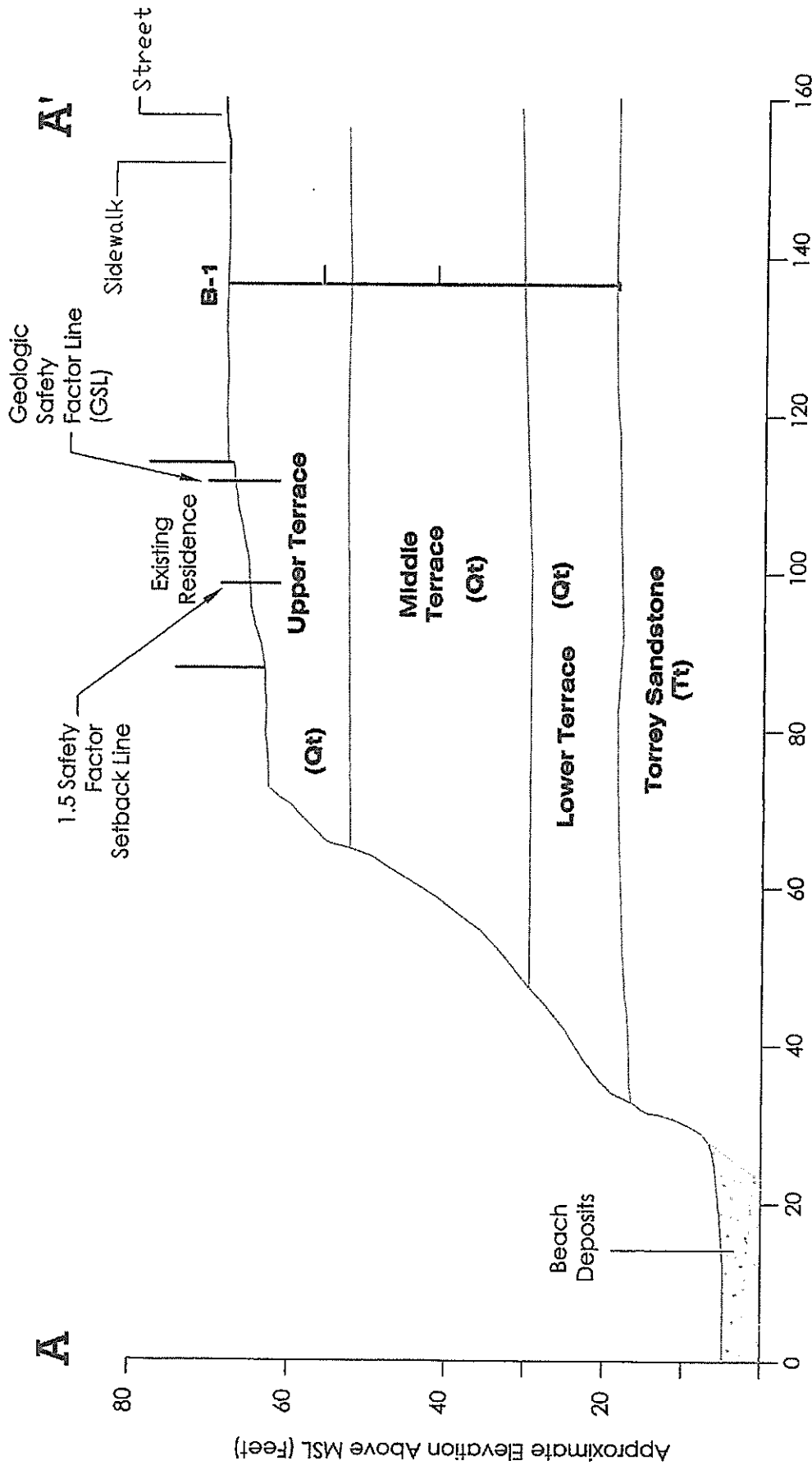
Harris Residence  
601 W. Circle Drive  
Solana Beach, CA.  
Figure No. 1  
Job No. 11-10035



NOTE: This Plot Plan is not to be used for legal purposes. Locations and dimensions are approximate. Actual property dimensions and locations of utilities may be obtained from title records, Building Plans or the "As-Built" Grading Plans.

# GEOLOGIC CROSS SECTION A-A'

Harris Residence  
601 W. Circle Drive  
Solana Beach, CA.



Relative Horizontal Distance (feet)  
Scale: 1" = 20'  
(Horizontal and Vertical)

Figure No. Via  
Job No. 11-10035



August 2017

NOTE: This Cross Section is not to be used for legal purposes. Locations and dimensions are approximate. Actual property dimensions and locations of utilities may be obtained from the Approved Building Plans or the "As-Built" Grading Plans.

11-10035-AA





# Geotechnical Exploration, Inc.

SOIL AND FOUNDATION ENGINEERING • GROUNDWATER • ENGINEERING GEOLOGY

RECEIVED

24 May 2017

JUN -1 2017

Planning-Comm Dev Dept  
City of Solana Beach

**Job No. 11-10035**

Lisa and Scott Harris  
601 W. Circle Drive  
Solana Beach, CA 92075

Subject: **Plan Review and Updated Geotechnical Investigation**  
Harris Residence  
601 W. Circle Drive  
Solana Beach, California

Dear Mr. and Mrs. Harris:

At the request of Mr. Jim Dyjak of Dyjak Design Build, and as required by the City of Solana Beach, ***Geotechnical Exploration, Inc.*** hereby provides this update letter and confirms that we have reviewed our previous geotechnical report, dated July 20, 2011, and the pertinent parts of the building plans dated March 15, 2017. The reviewed plans were prepared by D. Scott Hall Designs for the current project. The plans were found to be in general conformance with our geotechnical report and the latest geotechnical report by TerraCosta Consulting Group, dated July 8, 2013. It should be noted that our report was attached as Appendix A of the TerraCosta report and now we are being asked to take over as Geotechnical Consultant of Record. We have reviewed and accept all findings and recommendations of the TerraCosta report.

The scope of the project has changed since the issuance of our original report, in that, the structure will undergo a remodel of the interior within the existing building footprint and the only new foundation additions are adjacent to the front entry on the east side of the home. Based upon our understanding of the proposed addition at the subject site, we do not believe that the proposed improvements will have any

impact on bluff stability. New foundations should bear on properly compacted fill or dense natural soils.

The findings and opinions presented herein have been made in accordance with currently accepted principles and practice in the field of geotechnical engineering in the City of Solana Beach. No warranty, either expressed or implied, is made.

If you have any questions regarding this letter, please contact our office. Reference to our **Job No. 11-10035** will help expedite a response to your inquiry.

Respectfully submitted,

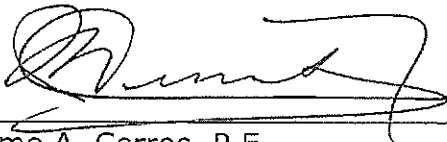
**GEOTECHNICAL EXPLORATION, INC.**



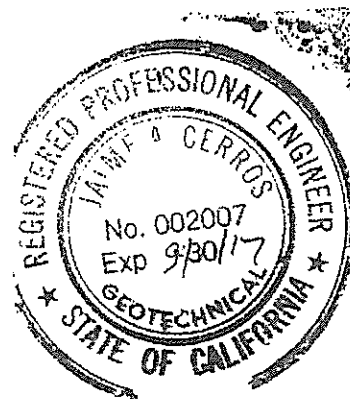
Jay K. Heiser, Senior Project Geologist



Leslie D. Reed, President  
C.E.G. 999/P.G. 3391



Jaime A. Cerros, P.E.  
R.C.E. 34422/G.E. 2007  
Senior Geotechnical Engineer



RECEIVED

MAR 20 2017

Planning-Comm Dev Dept  
City of Solana Beach

GEOTECHNICAL INVESTIGATION  
AND BLUFF STABILITY STUDY  
**601 WEST CIRCLE DRIVE**  
SOLANA BEACH, CALIFORNIA

Prepared for  
**Mr. Scott Harris**  
Solana Beach, California



Prepared by  
TERRACOSTA CONSULTING GROUP, INC.  
San Diego, California

Project No. 2800  
July 8, 2013



Project No. 2800  
July 8, 2013

*Geotechnical Engineering*  
*Coastal Engineering*  
*Maritime Engineering*

Mr. Scott Harris  
601 W. Circle Drive  
Solana Beach, California 92075

**GEOTECHNICAL INVESTIGATION  
AND BLUFF STABILITY STUDY  
601 WEST CIRCLE DRIVE  
SOLANA BEACH, CALIFORNIA**

Dear Mr. Harris:

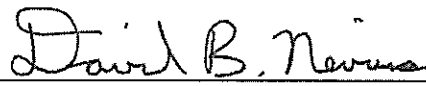
In accordance with your request, we have performed a geotechnical investigation and bluff stability study for the proposed renovations of the single-family residence located at 601 West Circle Drive in Solana Beach, California.


The accompanying report presents the results of our engineering analyses of the subsurface conditions at the site, and presents our conclusions and recommendations pertaining to the geotechnical aspects of site development.

We appreciate the opportunity to work with you on this project, and trust this information meets your present needs. If you have any questions or require further information, please give us a call.

Very truly yours,

TERRACOSTA CONSULTING GROUP, INC.

  
\_\_\_\_\_  
David B. Nevius, Project Engineer  
R.C.E. 65015, R.G.E. 2789

  
\_\_\_\_\_  
Braven R. Smillie, Principal Geologist  
R.G. 402, C.E.G. 207

DBN/BRS/jg

(4) Addressee

## TABLE OF CONTENTS

1	INTRODUCTION AND PROJECT DESCRIPTION .....	1
1.1	Previous Studies.....	1
2	PURPOSE AND SCOPE OF WORK.....	2
3	SITE CONDITIONS .....	2
3.1	Existing Conditions.....	2
3.2	Proposed Improvements.....	3
4	PHYSIOGRAPHY AND GEOLOGY .....	3
4.1	Geologic Units .....	3
4.2	Groundwater .....	4
4.3	Seismicity.....	5
4.4	Geologic Structure .....	5
5	GEOLOGIC HAZARDS.....	5
5.1	Faulting and Seismicity.....	5
5.2	Landslides .....	6
6	GROSS STABILITY AND EROSION OF THE COASTAL BLUFF.....	6
6.1	Soil Conditions.....	6
6.2	Stability Analysis.....	6
6.3	Coastal Bluff Erosion.....	7
7	GEOTECHNICAL CONCLUSIONS AND RECOMMENDATIONS.....	8
7.1	General.....	8
7.2	Shallow Foundations.....	8
7.2.1	Bearing Capacity.....	8
7.2.2	Settlement .....	9
7.2.3	Lateral Resistance .....	9
7.2.4	Concrete Slabs-on-Grade .....	9
7.2.5	Utilities and Trenches .....	9
7.2.6	Water- and Damp-Proofing Foundation Systems .....	10
7.3	Drilled Piers .....	10
7.3.1	Vertical Loads on Drilled Shaft Foundations.....	10
7.3.2	Lateral Loads on Drilled Pier Foundations .....	10
7.3.3	Bluff-Top Lateral Pier Capacity .....	11
8	LIMITATIONS .....	12

## REFERENCES



**TABLE OF CONTENTS**  
**(continued)**

FIGURE 1 - SITE VICINITY MAP

FIGURE 2 - SITE PLAN

FIGURE 3 - GENERALIZED GEOLOGIC CROSS SECTION

APPENDIX A - GEI REPORT OF LIMITED GEOTECHNICAL INVESTIGATION  
AND COASTAL BLUFF STABILITY EVALUATION DATED JULY  
20, 2011

APPENDIX B - RESULTS OF SLOPE STABILITY ANALYSES

APPENDIX C - EXCERPT FROM NAVFAC DM-7.2



GEOTECHNICAL INVESTIGATION  
AND BLUFF STABILITY STUDY  
**601 WEST CIRCLE DRIVE**  
SOLANA BEACH, CALIFORNIA

## 1 INTRODUCTION AND PROJECT DESCRIPTION

The subject property is located on the west side of West Circle Drive in the City of Solana Beach, California (see Figure 1, Vicinity Map). The site is located on the westerly facing coastal bluff, which descends approximately 65 feet from the top-of-bluff, down to the Pacific shoreline about 650 feet northerly of the Tide Beach Park stairway access. The Site Plan (Figure 2) and the generalized geologic Cross Section (Figure 3) summarize the general topographic and geologic conditions at the site. This report is intended to address bluff stability, setback lines, and geotechnical recommendations for a proposed addition to the existing residence.

### 1.1 Previous Studies

Group Delta Consultants, Inc. (GDC), the predecessor firm to TerraCosta Consulting Group, Inc. (TCG), previously prepared a comprehensive shoreline erosion study for the approximately 4,000 feet of coastline extending from the northerly city limits, to the Las Brisas Condominium complex just south of Fletcher Cove (GDC, 1998). TCG has performed numerous geotechnical investigations along this section of Solana Beach, including several sites in the near vicinity at 629 and 633 West Circle Drive to the north and 525, 521, 517, and 509 Pacific Avenue to the south. Those documents were reviewed for the preparation of this report.

Geotechnical Exploration, Inc. (GEI) previously performed a study at the subject site and prepared a report titled "Report of Limited Geotechnical Investigation and Coastal Bluff Stability Evaluation, Harris Residence, 601 W. Circle Drive, Solana Beach, California" dated July 20, 2011. Portions of that report, including the results of GEI's subsurface exploration program, have been considered in our investigation. A copy of the GEI report is provided in Appendix A.



## 2 PURPOSE AND SCOPE OF WORK

The purpose of our study is to provide geotechnical information to assist you and your consultants in project design, and to address City of Solana Beach and California Coastal Commission requirements regarding the geotechnical aspects of the project.

Our investigation also included review of existing documents prepared for other sites in the project vicinity, as well as the measurement of the rear-yard edge-of-bluff.

In particular, our investigation is designed to address the following geotechnical issues:

- The geologic setting of the site;
- Potential geologic hazards;
- Geotechnical characteristics of the on-site soils;
- Groundwater;
- Foundation design, including allowable soil bearing and earth pressure values; and
- Gross stability of the coastal bluff.

Additional recommendations regarding civil/site development can be found in GEI's report (Appendix A).

## 3 SITE CONDITIONS

### 3.1 Existing Conditions

As previously described, the subject property is located on the west side of West Circle Drive in the City of Solana Beach, California. The site is located on the westerly facing coastal bluff, which descends approximately 65 feet from the top-of-bluff, down to the Pacific shoreline about 650 feet northerly of the Tide Beach Park stairway access. The subject bluff-top is currently occupied by a one-story single-family residence. The footprint of the existing structure is shown on the Site Plan (Figure 2). Exterior improvements include concrete driveway and walkways, fences between adjacent neighboring properties, and a rear yard wood deck.





### 3.2 Proposed Improvements

We have been provided with and reviewed a 4-page set of drawings prepared by Friehauf Architects dated July 3, 2013, for the subject site. It is our understanding that the existing single-story residence will be renovated, including additional living space on the ground floor, as well as a second-story addition. We further understand that the proposed additions are to be supported on a combination of deepened footings and conventional foundations, including perimeter footings and slabs on grade. We understand that all new square footage will be supported by foundation elements constructed landward of the 1.5 factor of safety line.

## 4 PHYSIOGRAPHY AND GEOLOGY

The Solana Beach coastline extends approximately 1.4 miles from the south side of San Elijo Lagoon to the projection of Via De La Valle, the southerly City limits. The coastal bluffs extend southerly an additional 0.3 mile to the San Dieguito River Valley. This reach of coastline consists of steep coastal bluffs ranging in height from approximately 65 to 90 feet, with the seaward edge of the coastal bluff in the site vicinity generally ranging from 63 to 69 feet in approximate elevation.

Geologic units present in the site vicinity include the older Eocene "bedrock" geologic unit that forms the lower cliffed portion of the bluffs and the late Pleistocene marine terrace deposits that form the sloping upper coastal bluffs above the sea cliffs (Kennedy and Peterson, 1975). Limited amounts of fill (1 to 3 feet in thickness) and topsoil (2 to 3 feet in thickness) also exist at the subject site, as revealed in exploratory borings and test pits performed by GEI during their previous investigation at the site. Logs of exploratory borings and test pits from GEI are provided in Appendix A. Locations of the borings and test pits are indicated in GEI's report and on Figure 2.

### 4.1 Geologic Units

The Eocene-age bedrock unit consists of the Torrey Sandstone, a well-indurated (cemented), light gray to light yellow-brown, medium- to coarse-grained sandstone. The lower portions of the Torrey Sandstone contain bioturbated beds and concretions, while the upper portions exhibit high-angle cross-bedding (Kennedy and Peterson, 1975).



The sloping upper portion of the Solana Beach coastal bluffs is comprised of late Pleistocene, moderately-consolidated, poorly-indurated, light reddish-brown, silty fine sands that include both nearshore marine and beach sands lithologically similar to the Bay Point Formation (approximately 120,000 years old). The terrace deposits are capped by an approximately 10-foot-thick iron oxide-cemented "beach ridge" type residual clayey sand deposit. This erosion-resistant capping material, formed by the concentration of clayey weathering products, secondary oxides of iron and aluminum, and leached and re-precipitated salts, is the result of long exposure to the elements during a period of tropical to temperate climate. The lower 10 feet of the terrace deposits, at approximate elevation 18 to 28 feet at the site, consist of clean cohesionless sands that are highly susceptible to erosion, and responsible for the many upper-bluff failures that have occurred in Solana Beach in the past decade.

The marine terrace deposits overlie a wave-cut abrasion platform, formed on the Eocene bedrock approximately 120,000 years ago when sea level was 20 feet higher (Lajoie and others, 1992). At the time, the sea was at a high eustatic level due to substantial melting of the ice caps during an interglacial period. Today, the abrasion platform is approximately elevation 18 feet at the site. The difference in elevation is a result of variable regional uplift associated with gentle tectonic folding during the last 120,000 years.

Near-surface soils include an approximately 1 to 3-foot-thick layer of loose to medium dense fill, underlain by a 2 to 3-foot-thick layer of topsoil.

A geologic cross section through the subject property is presented in Figure 3, and is based on as-surveyed bluff geometries, with the section location as shown on the Site Plan, Figure 2.

#### 4.2 **Groundwater**

Unlike the other north San Diego County Eocene formations (the Santiago and Delmar Formations), the Torrey Sandstone does not create an impermeable perching horizon, which would encourage groundwater to exit to the bluff face along the contact between the coastal terrace deposits and the underlying cliff-forming Eocene-age formation. Although groundwater surfacing at the face of the bluff, causing sloughing and spring sapping, is often a problem within other north San Diego County coastal areas, the Solana Beach coastline, and this site in particular, appears to be relatively immune to this type of subaerial processes.



### 4.3 Seismicity

The project area is located in a moderately active seismic region of Southern California that is subject to moderate to strong shaking from nearby and distant earthquakes. Ground shaking from earthquakes on six major active fault zones could affect the site. These would include the Rose Canyon, Coronado Bank, San Diego Trough, San Clemente, Elsinore, and San Jacinto/Superstition Hills fault zones. The nearest of these, the Rose Canyon fault zone, parallels the shoreline and is located approximately 3.5 kilometers (about 2.2 miles) southwest of the site. The maximum credible earthquake for the Rose Canyon Fault is considered to be Magnitude 7.2.

### 4.4 Geologic Structure

Movement along the Rose Canyon Fault appears to have caused gentle folding on the coastal side of the fault. The gentle folding has caused a small southeast dip in the Eocene-age formation, thus exposing progressively older formations northerly along the coast. More recently, the 120,000-year-old wave-cut abrasion platform has been tilted to the northwest at about 0.1 degree. Tectonic forces are also evident in the localized folding and faulting of the Eocene-age sediments. The episodes of faulting and long-continued tectonic stresses have resulted in hundreds of visible joints, fractures, and shear zones having both micro- and large-scale variations in erosion potential.

## 5 GEOLOGIC HAZARDS

### 5.1 Faulting and Seismicity

The site is located in a moderately active seismic region of Southern California that is subject to significant hazards from moderate to large earthquakes. Ground shaking from sixteen major active fault zones could affect the site in the event of an earthquake. The nearest of these, the northerly offshore extension of the Rose Canyon fault zone, trends north-northwest and has been mapped approximately 3.8 miles southwest of the site. No known active faults have been mapped, nor were any observed during our geologic reconnaissance at, or in the immediate vicinity of, the site.



## 5.2 Landslides

Our study did not reveal the presence of any landslides on the site. No landslides have been mapped as being present, either on or immediately adjacent to the site.

# 6 GROSS STABILITY AND EROSION OF THE COASTAL BLUFF

## 6.1 Soil Conditions

In order to assess the stability of the upper bluff, slope stability analyses were performed using soil strengths for the upper terrace deposits as follows:

Upper Beach Ridge Deposits:  $\phi = 33$  degrees  
 $c = 600$  psf  
 $\gamma_t = 120$  pcf

Mid-Bluff Terrace Deposits:  $\phi = 33$  degrees  
 $c = 370$  psf  
 $\gamma_t = 120$  pcf

Lower Clean Sand Layer:  $\phi = 32$  degrees  
 $c = 0$  psf  
 $\gamma_t = 120$  pcf

## 6.2 Stability Analysis

The stability of the upper portion of the coastal bluff was evaluated with the computer software PCSTABL, which is a two-dimensional limit equilibrium slope stability program developed by Purdue University. Summary results of the coastal stability analyses are included in Appendix B for section locations shown on Figure 2. Static factors of safety range from 1.18 for Section B (Figure B-5), to 1.23 for Section C (Figure B-9). Additional analyses were conducted to establish the location of the bluff-top failure surface daylight line for a static factor of safety of 1.5. Those results are depicted on Figure 2.

Pseudostatic analyses, using a horizontal seismic coefficient of 0.15g, have also been performed consistent with the guidelines contained in Bulletin 117. These analyses are also included in Appendix B, and the failure surface from the pseudostatic analysis is also shown on Figure 2.



Based upon our understanding of the proposed addition at the subject site, we do not believe that the proposed improvements will have any impact on bluff stability.

### 6.3 Coastal Bluff Erosion

The Solana Beach coastline has experienced a measurable amount of erosion in the last 15+ years, in large part due to the effects of the 1997-98 El Niño storm season. The entire base of the sea cliff is currently exposed to direct wave attack all along the coast. The waves erode the sea cliff by mechanical abrasion at the base of the sea cliff, and by impact on small joints and fissures in the otherwise massive rock units, and by water-hammer effects. The upper bluffs, which typically support little or no vegetation, are subject to wave spray and splash, sometimes causing saturation of the outer layer and subsequent sloughing of oversteepened slopes. Wind, rain, irrigation, and uncontrolled surface runoff contribute to minor erosion of the upper coastal bluff, especially on the more exposed, oversteepened portions of the friable sands. Where these processes are active, rilling has resulted along portions of the upper bluffs.

Bluff-top retreat under natural conditions is the end result of erosion processes (both marine and subaerial) acting primarily on the sea cliff and upper bluff. The contribution from erosion of the coastal terrace (landward of the bluff top) is generally smaller and can be reduced to negligible amounts by careful landscaping, control of surface runoff, and prevention of human traffic near the bluff top.

Geomorphic techniques can be used to describe the progressive nature of bluff-top retreat. This requires breaking the problem down into upper and lower bluff (sea cliff) component processes, and developing an understanding of the interaction between the two components.

Although bluff retreat is episodic and site-specific, characteristically coinciding with major storm events, the rates of retreat of both upper and lower components of the bluffs at Solana Beach are approximately equal over the longer term (defined here as several hundreds of years). Continuing long-term retreat of the lower bluff gradually creates an oversteepened slope in the upper bluff, causing it to decline (by erosion and/or slope failure) to a more sustainable angle of repose. The process continues and repeats in a series of episodes. In the Solana Beach area before the 1997-98 El Niño storm season, upper-bluff slope inclinations characteristically ranged between approximately 37 and 53 degrees. As the upper-bluff slope approaches the high end of this range, episodes of massive slope failure are typically caused



by insufficient soil strengths to sustain the steeper slope angles and are often aggravated by the combined effects of groundwater seepage and rainfall.

Based upon our site reconnaissance, study of historic coastal photos, and review of previous studies, we estimate the coastal bluff erosion for this section of Solana Beach to be on the order of 0.4 foot (4.8 inches) per year. This erosion rate would correspond to 30 feet of erosion over a period of 75 years.

## 7 GEOTECHNICAL CONCLUSIONS AND RECOMMENDATIONS

### 7.1 General

Our investigation did not reveal the presence of any adverse geologic conditions on the site, such as faults, adverse bedding, or a high groundwater table, that would preclude development of the proposed construction as presently planned.

### 7.2 Shallow Foundations

#### 7.2.1 *Bearing Capacity*

For foundations having a minimum width of 12 inches and founded on formational materials (Bay Point Formation), we recommend an allowable net bearing pressure of 2,000 psf. As previously described, our site investigation indicates that formational materials may be located on the order of 3 to 6 feet below grade due to the presence of fill materials and topsoil. In those locations, we recommend removal of loose fill and topsoil materials down to formational materials, and replacement with suitable structural backfill compacted to a minimum relative compaction of 90 percent based upon ASTM D1557-09. In addition, we recommend that adjacent footings not be founded above an imaginary plane extending upward at an angle of 45 degrees from the bottom outside edge of an adjacent lower footing. Additionally, we recommend that all footings be adequately reinforced as recommended by a structural engineer experienced with the design of shallow foundation systems. Footing excavations should be cleared of any loose material prior to concrete placement. Lastly, we recommend that the geotechnical engineer inspect all footing excavations to ensure placement on competent materials.



### 7.2.2 *Settlement*

We estimate that footings loaded to an allowable bearing pressure of 2,000 psf will settle approximately 1/2 inch or less, with differential settlements on the order of 1/4 inch or less.

### 7.2.3 *Lateral Resistance*

To provide resistance for design lateral loads of footings and shear keys poured neat against vertical excavations, we recommend using an equivalent fluid pressure of 300 or 450 pcf for properly compacted granular fill or competent formational materials, respectively. These values assume a horizontal surface for the soil mass extending at least 10 feet from the face of the footing or three times the height of the surface generating the passive pressure, whichever is greater. The upper 12 inches of soil in areas not protected by floor slabs or pavements should not be included in design for passive resistance to lateral loads.

If friction is to be used to resist lateral loads, we recommend an allowable coefficient of friction of 0.40 between soil and concrete for either compacted fill or formational soil. If it is desired to combine friction and passive resistance in design, we recommend reducing the friction coefficient by 25 percent.

### 7.2.4 *Concrete Slabs-on-Grade*

We recommend that concrete slabs-on-grade be designed in accordance with the UBC and the American Concrete Institute's (ACI) Committee Report No. 360. In addition, we recommend that the construction of concrete slabs-on-grade conform to the guidelines and specifications presented in ACI Committee Report No. 302.

### 7.2.5 *Utilities and Trenches*

Open or backfilled trenches parallel with a footing shall not be below a plane having a downward slope of 1 unit vertical to 2 units horizontal (50 percent slope) from a line 9 inches above the bottom edge of the footing and not closer than 18 inches from the face of such footing.



Where utilities cross under footings, the footings shall be specially designed. Pipe sleeves shall be provided where pipe crosses through footings or footing walls, and sleeve clearances shall provide for possible footing settlement, but not less than 1 inch.

#### 7.2.6 *Water- and Damp-Proofing Foundation Systems*

As a minimum, we recommend that the foundation systems for the proposed structures be waterproofed and/or damp-proofed in accordance with the appendix to Chapter 18 of the 1997 UBC.

### 7.3 **Drilled Piers**

We understand that portions of the proposed addition are proposed to be supported by drilled pier foundations that achieve adequate lateral and axial capacity through sufficient embedment into the underlying terrace deposits. Geotechnical design criteria for both vertical and lateral load capacity are provided in the following sections.

#### 7.3.1 *Vertical Loads on Drilled Shaft Foundations*

We recommend that drilled shaft foundations supporting the proposed addition derive support from shaft friction in the formational terrace deposits only. We do not recommend relying on resistance from fill or topsoil deposits, which may comprise on the order of the upper 6 feet of drilled shaft. We recommend an allowable shaft friction of 600 psf within the terrace deposits to resist both dead plus live loads. No increase should be used for transient wind or seismic loads. It should be noted that this design precludes the need for cleaning the bottoms of drilled excavations, and thus does not rely on any tip bearing for vertical support.

We can provide recommended minimum embedment depths for anticipated axial loads.

#### 7.3.2 *Lateral Loads on Drilled Pier Foundations*

Resistance to lateral loads applied to the drilled pier is developed through deflection in the pier, which mobilizes the reaction of the soil into which the drilled pier is embedded. The resisting pressure applied by the soil to a pier depends upon the relative stiffness of the pier and soil, as well as depth of embedment.





Failure of a laterally loaded pier takes place either when the maximum bending moment in the loaded pier reaches the ultimate or yield resistance of the pier section, or when the lateral earth pressures reach the ultimate lateral resistance of the soil along the total length of the pier. For purposes of definition, failure of piers with relatively "short embedment" takes place when the pier rotates as a unit with respect to a point located close to its toe. Failures of piers with relatively "long embedment" occur when the maximum bending moment applied to the pier exceeds the yield resistance of the pier section, and a plastic hinge forms at the section of maximum bending moment.

Investigators have suggested that piers be grouped relative to their dimensionless depth of embedment  $L/T$  where:

$L$  = embedment length of the pier in feet, and

$$T = \left( \frac{EI}{f} \right)^{\frac{1}{5}} \text{ (divided by 12 to convert inches to feet)}$$

Short piers are generally defined as  $L/T$  being less than 2.0, and long piers are generally defined as  $L/T$  being larger than 4.0.

The quantity  $EI$  is the stiffness of the pier section, and  $f$  (coefficient of variation of soil modulus) would be on the order of 25 pounds per cubic inch for the upper bluff soils.

In order to determine the structural requirements and load deformation characteristics of the proposed concrete piers, we would suggest using the elastic theory approach developed by Matlock and Reese (1962). A condensed version of this approach is outlined in the NAVFAC Design Manual DM-7.2, Chapter 5, Section 7. A copy of the condensed DM-7.2 version is presented as Appendix C.

### 7.3.3 *Bluff-Top Lateral Pier Capacity*

Resistance to lateral pier capacity provided by passive resistance of the soil assumes a horizontal surface extending beyond the pier a minimum of 10 feet or three times the depth of assumed passive resistance. With a minimum design pier setback of 40 feet from the top-of-bluff, no lateral load limitations currently exist in any direction. Although drilled piers will not be exposed during the expected economic lifetime of any new construction, we



would recommend that the design lateral pier capacity resisting loads in a westerly direction be limited to 6,600 times the pier diameter in pounds per drilled pier (2-foot-diameter pier = 13,200 pound lateral capacity). If additional lateral pier capacity is needed, we can provide additional design criteria once the overall drilled pier/grade beam foundation design has been developed.

## 8 LIMITATIONS

Geotechnical engineering and the earth sciences are characterized by uncertainty. Professional judgments presented herein are based partly on our evaluation of the technical information gathered, partly on our understanding of the proposed construction, and partly on our general experience. Our engineering work and judgments rendered meet the current professional standards. We do not guarantee the performance of the project in any respect.

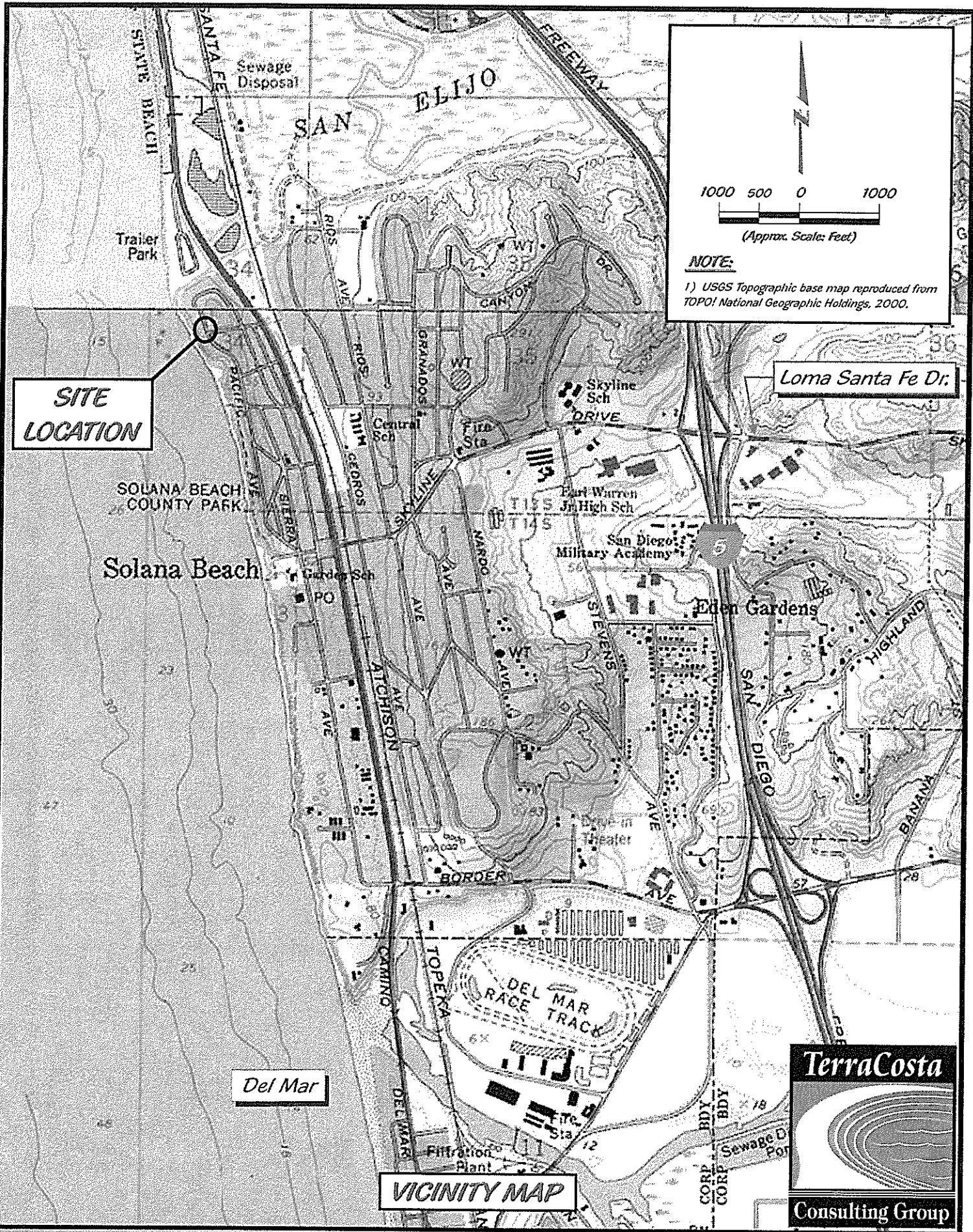
We have investigated only a small portion of the pertinent soil, rock, and groundwater conditions of the subject site. The opinions and conclusions made herein were based on the assumption that those rock and soil conditions do not deviate appreciably from those encountered during our investigation. We recommend that a soil engineer from our office observe construction to assist in identifying soil conditions that may be significantly different from those encountered in our borings. Additional recommendations may be required at that time.




## REFERENCES

- Group Delta Consultants, Inc., August 20, 1998, Shoreline Erosion Study, North Solana Beach, California, Project No. 1831.
- Group Delta Consultants, Inc., 1996, *Geotechnical Appendix (Appendix D of the 1996 Encinitas Shoreline Reconnaissance Report)*, prepared for the U.S. Army Corps of Engineers.
- Kennedy, M.P., and G.W. Moore, 1971, *Stratigraphic Relations of Upper Cretaceous and Eocene Formations, San Diego Coastal Area, California*, The American Association of Petroleum Geologists Bulletin, V. 55, N. 5, pp. 709-722.
- TerraCosta Consulting Group, Inc., January 25, 2008, Geotechnical Basis of Design, Seawall Maintenance, Repair, and Extension, 521 Pacific Avenue, Solana Beach, California.
- U.S. Department of Agriculture, 1953, Stereographic Aerial Photograph Nos. AXN-8M-79 through 81, flown 1953.
- U.S. Army Corps of Engineers, January 2003, Encinitas and Solana Beach Shoreline Feasibility Study, San Diego County, California.
- U.S. Department of the Navy, Naval Facilities Engineering Command, 1986, Foundations and Earth Structures, NAVFAC DM 7.02.





  
 1000 500 0 1000  
 (Approx. Scale: Feet)

**NOTE:**  
 1) USGS Topographic base map reproduced from TOPOI National Geographic Holdings, 2000.

**SITE  
LOCATION**

**Loma Santa Fe Dr.**

**Del Mar**

**VICINITY MAP**

**TerraCosta**



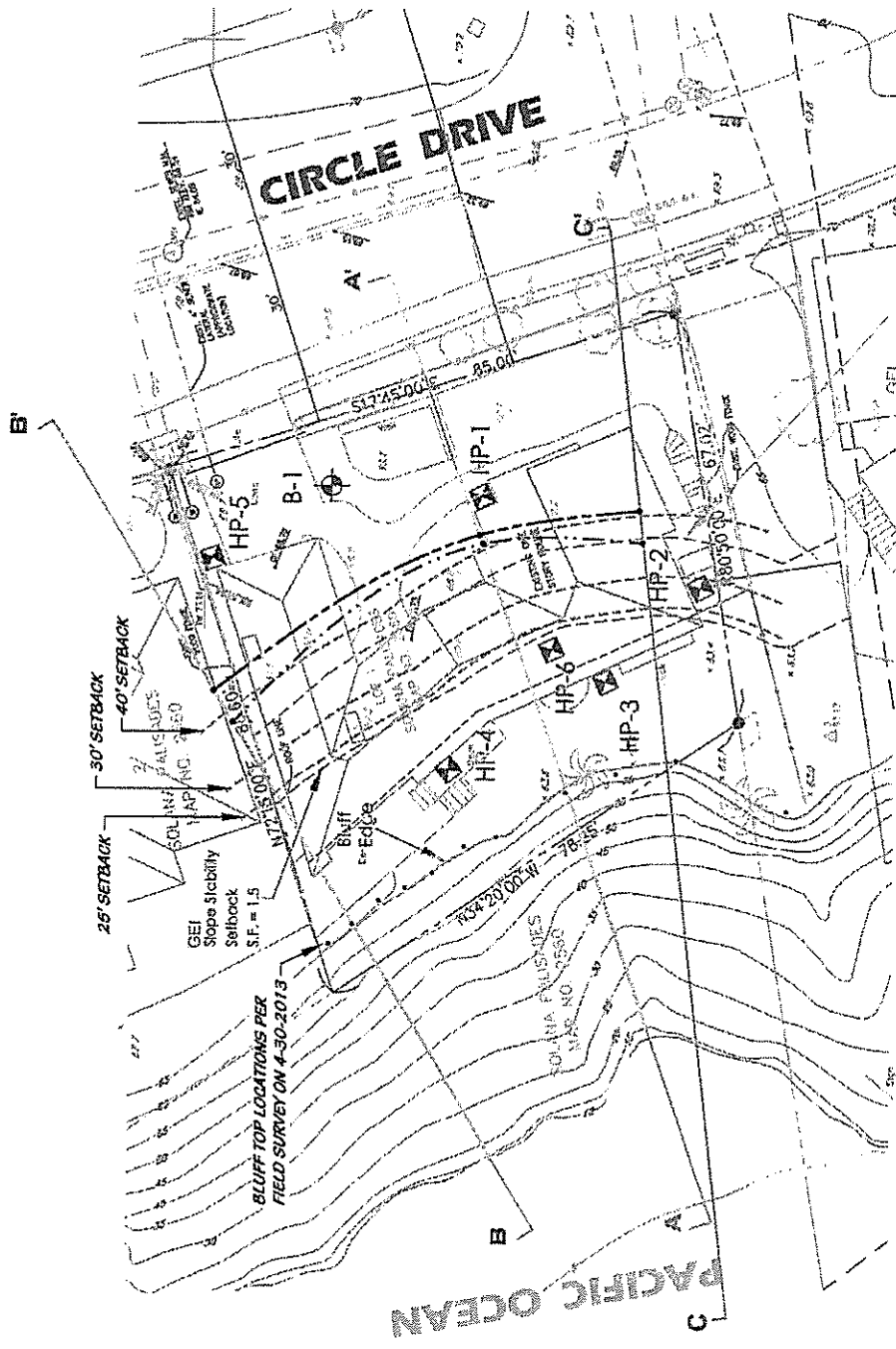
**Consulting Group**

**LEGEND**

- ASSUMED PROPERTY BOUNDARY
- APPROX. LOCATION GEI BORING
- APPROX. LOCATION GEI HANDPIT
- GEOLOGIC CROSS SECTION
- SLOPE STABILITY SETBACKS (GEI)
- SEISMIC FACTOR OF SAFETY = 1.1 (TGS)
- FACTOR OF SAFETY = 1.5 (TGS)



SCALE: 1"=20'



**TerraCosta Consulting Group**

TERRACOSTA CONSULTING GROUP 3000 MARIPOSA AVENUE, SUITE 200 SAN DIEGO, CA 92122 1888 373-8005	FIGURE NUMBER <b>2</b>
PROJECT NAME 601 CIRCLE DRIVE	PROJECT NUMBER 2800

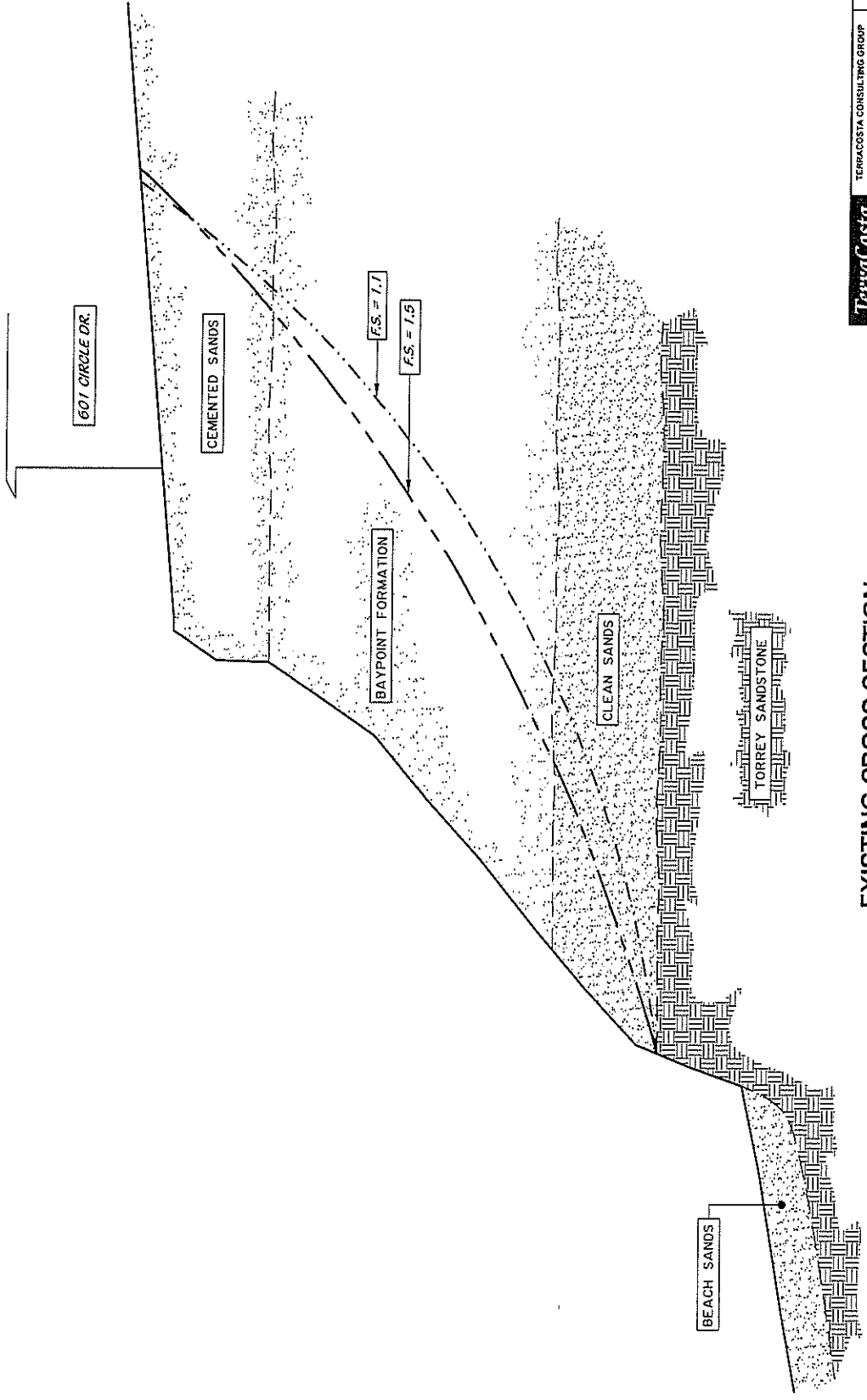
**SITE PLAN**

**AS/N-LD AERIAL SURVEYS**  
3725 VENTURA AVE., SAN DIEGO, CA 92123-1047 (619) 592-1234  
30' Deep Draw PLOTTING: 3-10-11  
CHECKED: 3-10-11  
CONTR. NUMBER: 1

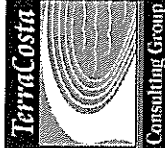
SHEET 1 OF 1

ELEVATION FEET, (MSL)

80  
70  
60  
50  
40  
30  
20  
10  
0



**EXISTING CROSS SECTION**  
**601 CIRCLE DRIVE**  
 SCALE: 1"=10' (HORIZ. & VERT.)



TERRACOSTRA CONSULTING GROUP 2895 MARYWAY CANYON ROAD, SUITE 200 SAN DIEGO, CA 92122 (619) 517-8828	PROJECT NUMBER 2000
PROJECT NAME 601 CIRCLE DRIVE	FIGURE NUMBER 3

**CROSS SECTION**

APPENDIX A

REPORT OF  
LIMITED GEOTECHNICAL INVESTIGATION AND  
COASTAL BLUFF STABILITY EVALUATION  
HARRIS RESIDENCE, 601 W. CIRCLE DRIVE  
SOLANA BEACH, CALIFORNIA  
DATED JULY 20, 2011  
PREPARED BY GEI



**REPORT OF LIMITED GEOTECHNICAL INVESTIGATION  
AND COASTAL BLUFF STABILITY EVALUATION**

Harris Residence  
601 W. Circle Drive  
Solana Beach, California

**JOB NO. 11-10035**  
20 July 2011

Prepared for:

***Mr. Scott Harris***







# Geotechnical Exploration, Inc.

SOIL AND FOUNDATION ENGINEERING • GROUNDWATER • ENGINEERING GEOLOGY

20 July 2011

Mr. Scott Harris  
601 W. Circle Drive  
Solana Beach, CA 92075

**Job No. 11-10035**

Subject: **Report of Limited Geotechnical Investigation and Coastal Bluff Stability Evaluation**  
Harris Residence  
601 W. Circle Drive  
Solana Beach, California

Dear Mr. Harris:

In accordance with your request and our proposal dated May 9, 2011, **Geotechnical Exploration, Inc.** has performed an investigation of the geotechnical and general geologic conditions at the location of the proposed new residence or additions and associated improvements. Additionally, we have performed a geologic reconnaissance of the site and bluff evaluation, per the requirements of the City of Solana Beach and the California Coastal Commission. The field work was performed on May 19, 2011.

In our opinion, if the conclusions and recommendations presented in this report are implemented during site preparation, the site will be suited for the proposed residential additions and associated improvements.

This opportunity to be of service is sincerely appreciated. Should you have any questions concerning the following report, please do not hesitate to contact us. Reference to our **Job No. 11-10035** will expedite a response to your inquiries.

Respectfully submitted,

**GEOTECHNICAL EXPLORATION, INC.**

Jaime A. Cerros, P.E.  
R.C.E. 34422/G.E. 2007  
Senior Geotechnical Engineer

Leslie D. Reed, President  
C.E.G. 999[exp. 3-31-13]/R.G. 3391

## TABLE OF CONTENTS

	<u>PAGE</u>
I. PROJECT SUMMARY	1
II. SITE DESCRIPTION	3
III. FIELD INVESTIGATION	4
IV. FIELD & LABORATORY TESTS AND SOIL INFORMATION	5
V. REGIONAL GEOLOGIC DESCRIPTION	8
VI. SITE-SPECIFIC GEOLOGIC DESCRIPTION	12
VII. PRELIMINARY BLUFF STABILITY ANALYSES	18
VIII. GEOLOGIC HAZARDS	20
IX. GROUNDWATER	25
X. CONCLUSION AND RECOMMENDATIONS	25
XI. GRADING NOTES	54
XII. LIMITATIONS	54

### **REFERENCES**

### **FIGURES**

- I. Vicinity Map
- II. Plot Plan
- IIIa-h. Exploratory Boring and Excavation Logs
- IV. Laboratory Test Results
- Va-b. Geologic Map and Legend
- VIa-b. Cross Section A – A' and B – B'
- VII. Caisson Embedment Schematic
- VIII. Retaining Wall Drainage Schematic

### **APPENDICES**

- A. Unified Soil Classification System
- B. Seismic Data – EQFault
- C. Seismic Data - EQSearch
- D. Modified Mercalli Intensity Index
- E. Spectral Acceleration vs. Period T
- F. Slope Stability Analysis



**REPORT OF LIMITED GEOTECHNICAL INVESTIGATION AND  
COASTAL BLUFF STABILITY EVALUATION**

Harris Residence  
601 W. Circle Drive  
Solana Beach, California

**JOB NO. 11-10035**

The following report presents the findings and recommendations of *Geotechnical Exploration, Inc.* for the subject project.

**I. PROJECT SUMMARY**

It is our understanding, based on discussions with Mr. Jim Sneed of Bokal and Sneed Architects, that two options are under consideration for this property. The first option is to demolish the existing residence and construct a new single-family residence. The new residence is to be constructed of standard-type building materials utilizing either a conventional foundation system and a slab on-grade in compacted fill soils or a deepened foundation system on the existing fill soils. The new residence will be constructed behind the 25-foot setback and sea cliff recession and slope stability setback required for construction along the coast.

The second option under consideration is to remodel the existing single-story residential structure including the construction of a second-story addition and possible improvement of the existing crawl space for construction of a basement. The proposed second-story addition is to be constructed of standard-type building materials utilizing a deepened foundation system of caissons and/or, where needed, by underpinning the existing footings. The basement addition is to be constructed utilizing a conventional foundation system with perimeter foundations and a slab on-grade.



Under the second option, the western portion of the home is to remain within the existing footprint and bearing loads of the planned additions will be constructed behind the 25-foot setback and sea cliff recession and slope stability setback required for construction along the coast. The existing home and proposed addition areas are underlain by shallow fill soils placed prior to 1953 during grading operations performed to produce the current building pad and existing improvements. Based on our site observations and review of provided documents, it appears that the bluff height is approximately 55 to 60 feet.

Construction plans for development of the site have not been provided to us during the preparation of this report, however, when completed they should be made available for our review. Additional or modified recommendations may be provided by our firm. The scope of work we performed is briefly outlined as follows:

1. Identify and classify the surface and subsurface soils in the area of the proposed construction, in general conformance with the Unified Soil Classification System.
2. Make note of any landslides, faults or significant geologic features that may affect the development of the site.
3. Evaluation of existing coastal bluff stability as it relates to the proposed new construction.
4. Recommend site soil preparation procedures.
5. Recommend the allowable bearing pressures for the on-site natural soils and properly compacted fills.



6. Evaluate the settlement potential of the existing formational soils or proposed properly compacted fills under the new structural loads.
7. Provide preliminary foundation design information, including active and passive earth pressures to be utilized in design of proposed retaining walls, below-grade retaining walls and foundation structures.

Our subsurface investigation revealed that the site is underlain at relatively shallow depth by medium dense silty sand marine terrace materials underlain by dense to very dense silty sand formational materials. It is recommended that the fill soils and any loose topsoil be removed and recompacted as part of site preparation prior to the addition of any new fill or structural improvements.

All foundations for a new second-story addition should be founded into the underlying medium dense to dense terrace/formational materials or properly compacted fill soils. In proposed secondary improvement areas, all existing fill soils will require removal and recompaction prior to placement of new fill or improvements.

The existing coastal bluff is considered stable in its current configuration and, in our opinion, should not be affected by the proposed new development.

## **II. SITE DESCRIPTION**

The property is known as Assessor's Parcel No. 263-021-01-00, Lot 1 of Solana Palisades, according to Recorded Map 2560, in the City of Solana Beach, County of San Diego, State of California.



The roughly square-shaped site, consisting of approximately 6,300 square feet (0.15-acre), is located at 601 W. Circle Drive (for site location, refer to the Vicinity Map, Figure No. I). The property is on the northwest corner of the intersection of W. Circle Drive and Ocean Street and is bounded to the north and south by similar residential properties at approximately the same elevation; to the east by W. Circle Drive; and to the west by a westerly descending ocean bluff and the Pacific Ocean (for Site Plan, refer to Figure No. II).

The primary existing structure on the property is a single-story residence with an attached one-car garage. The original home was constructed prior to 1953. Access to the property is provided by a concrete driveway at the northeast corner of the property. Property line fences form the north and south boundaries of the property. Exterior improvements consist of concrete walkways and a rear yard wood deck. Based on review of historic photographs and topographic maps, it appears the home underwent a significant remodel between 1953 and 1985.

The property consists of a split-level building pad constructed at the top of a coastal bluff. The bluff descends to the beach and the Pacific Ocean. The building pad elevation ranges from 69 feet above mean sea level (AMSL) to 63 feet AMSL. Elevations across the property range from approximately 69 feet AMSL along the eastern property line adjacent to W. Circle Drive to approximately 55 feet AMSL along the western edge of the property, approximately 10 feet west of the descending coastal bluff.

Information concerning approximate elevations across the site was obtained from topographic information included on the site plan prepared by JP Civil Engineering and Surveying.



### **III. FIELD INVESTIGATION**

One exploratory boring and six handpits were placed in areas near where the proposed structure/additions and improvements are to be located and where access and soil conditions allowed (for exploratory boring and excavation locations, refer to Figure No. II). The exploratory boring was excavated to a depth of 50.7 feet and the handpits were excavated to depths ranging from 2 to 6 feet in order to obtain representative soil samples and to define a soil profile across the lot. The boring was intentionally placed through the full thickness of the marine terrace deposits and terminated in the Eocene-age Torrey Sandstone Formation.

The soils encountered in the boring and handpits were logged by our field representative and samples were taken of the predominant soils throughout the field operation. Exploratory logs have been prepared on the basis of our observations and laboratory testing. The results have been summarized on Figure Nos. III and IV. The predominant soils have been classified in general conformance with the Unified Soil Classification System (refer to Appendix A).

### **IV. FIELD AND LABORATORY TESTS AND SOIL INFORMATION**

#### **A. Field Tests**

Relatively undisturbed samples were obtained by driving a 3-inch outside-diameter (O.D.) by 2-3/8-inch inside-diameter (I.D.) split-tube sampler a distance of 12 inches. Standard Penetration Tests were also performed by using a 140-pound weight falling 30 inches to drive a 2-inch O.D. by 1-3/8-inch I.D. sampler tube a distance of 18 inches. The number of blows required to drive the sampler the last 12 inches was recorded for use in evaluation of the soil consistency. The following



chart provides an in-house correlation between the number of blows and the consistency of the soil for the Standard Penetration Test and the 3-inch sampler.

<b>SOIL</b>	<b>DENSITY DESIGNATION</b>	<b>2-INCH O.D. SAMPLER BLOWS/FOOT</b>	<b>3-INCH O.D. SAMPLER BLOWS/FOOT</b>
Sand and Non-plastic Silt	Very loose	0-4	0-7
	Loose	5-10	8-20
	Medium	11-30	21-53
	Dense	31-50	54-98
	Very Dense	Over 50	Over 98
Clay and Plastic Silt	Very soft	0-2	0-2
	Soft	3-4	3-4
	Firm	5-8	5-9
	Stiff	9-15	10-18
	Very Stiff	15-30	19-45
	Hard	31-60	46-90
	Very Hard	Over 60	Over 90

**B. Laboratory Tests**

Laboratory tests were performed on retrieved soil samples in order to evaluate their physical and mechanical properties and their ability to support the proposed residential structure additions and improvements. Test results are presented on Figure Nos. III and IV. The following tests were conducted on the sampled soils:

1. *Moisture Content (ASTM D2216-07)*
2. *Density Measurements (ASTM D1586-08)*
3. *Laboratory Compaction Characteristics (ASTM D1557-09)*
4. *Determination of Percentage of Particles Smaller than #200 Sieve (ASTM D1140-06)*
5. *Direct Shear Test (ASTM D3080-04)*





The moisture content (ASTM D2216) of a soil sample is a measure of the water content, expressed as a percentage of the dry weight of the sample. Density measurements (ASTM D1586) were performed on soils collected by the Split-Barrel Sampling of Soils of a sampler driven with a manual hammer. This helps to establish the in situ density of retrieved samples.

Laboratory compaction values (ASTM D1557) establish the Optimum Moisture content and the laboratory Maximum Dry Density of the tested soils. The relationship between the moisture and density of remolded soil samples gives qualitative information regarding existing fill compaction and soil compaction conditions to be anticipated during any future grading operation. In addition, this relation helps to establish the relative compaction of existing fill soils.

The passing -200 sieve size analysis (ASTM D1140) aids in classification of the tested soils based on their fine material content and provides qualitative information related to engineering characteristics such as expansion potential, permeability, and shear strength.

Direct shear tests (ASTM D3080) were performed on remolded soil samples in order to evaluate their strength characteristics. The shear tests were performed with a constant strain rate direct shear machine and under various normal loads.

The expansion potential of soils was not determined due to the granular nature of the soils. When necessary, expansion potential is determined utilizing the Standard Test Method for Expansion Index of Soils (ASTM D4829). In accordance with the Standard (Table 5.3), potentially expansive soils are classified as follows:



<b>EXPANSION INDEX</b>	<b>EXPANSION POTENTIAL</b>
0 to 20	Very low
21 to 50	Low
51 to 90	Medium
91 to 130	High
Above 130	Very high

Based on our particle-size test results, our visual classification, and our experience with similar soils, it is our opinion that the on-site silty sand materials have a very low expansion potential (EI less than 20).

Based on the laboratory test data, our observations of the primary soil types, and our previous experience with laboratory testing of similar soils on nearby properties, our Geotechnical Engineer has assigned values for the angle of internal friction and cohesion to those soils that will provide significant lateral support or load bearing on the project. These values have been utilized in assigning the recommended bearing value as well as active and passive earth pressure design criteria for foundations and retaining walls and for slope stability calculations.

#### **V. REGIONAL GEOLOGIC DESCRIPTION**

San Diego County has been divided into three major geomorphic provinces: the Coastal Plain, Peninsular Ranges and Salton Trough. The Coastal Plain exists west of the Peninsular Ranges. The Salton Trough is east of the Peninsular Ranges. These divisions are the result of the basic geologic distinctions between the areas. Mesozoic metavolcanic, metasedimentary and plutonic rocks predominate in the Peninsular Ranges with primarily Cenozoic sedimentary rocks to the west and east of this central mountain range (Demere, 1997).



In the Coastal Plain region, where the subject property is located, the "basement" consists of Mesozoic crystalline rocks. Basement rocks are also exposed as high relief areas (e.g., Black Mountain northeast of the subject property and Cowles Mountain near the San Carlos area of San Diego). Younger Cretaceous and Tertiary sediments lap up against these older features. The Cretaceous sediments form the local basement rocks on the Point Loma area. These sediments form a "layer cake" sequence of marine and non-marine sedimentary rock units, with some formations up to 140 million years old. Faulting related to the La Nacion and Rose Canyon Fault zones has broken up this sequence into a number of distinct fault blocks in the southwestern part of the county. Northwestern portions of the county are relatively undeformed by faulting (Demere, 1997).

The Peninsular Ranges form the granitic spine of San Diego County. These rocks are primarily plutonic, forming at depth beneath the earth's crust 140 to 90 million years ago as the result of the subduction of an oceanic crustal plate beneath the North American continent. These rocks formed the much larger Southern California batholith. Metamorphism associated with the intrusion of these great granitic masses affected the much older sediments that existed near the surface over that period of time. These metasedimentary rocks remain as roof pendants of marble, schist, slate, quartzite and gneiss throughout the Peninsular Ranges. Locally, Miocene-age volcanic rocks and flows have also accumulated within these mountains (e.g., Jacumba Valley). Regional tectonic forces and erosion over time have uplifted and unroofed these granitic rocks to expose them at the surface (Demere, 1997).

The Salton Trough is the northerly extension of the Gulf of California. This zone is undergoing active deformation related to faulting along the Elsinore and San Jacinto Fault Zones, which are part of the major regional tectonic feature in the



southwestern portion of California, the San Andreas Fault Zone. Translational movement along these fault zones has resulted in crustal rifting and subsidence. The Salton Trough, also referred to as the Colorado Desert, has been filled with sediments to depth of approximately 5 miles since the movement began in the early Miocene, 24 million years ago. The source of these sediments has been the local mountains as well as the ancestral and modern Colorado River (Demere, 1997).

As indicated previously, the San Diego area is part of a seismically active region of California. It is on the eastern boundary of the Southern California Continental Borderland, part of the Peninsular Ranges Geomorphic Province. This region is part of a broad tectonic boundary between the North American and Pacific Plates. The actual plate boundary is characterized by a complex system of active, major, right-lateral strike-slip faults, trending northwest/southeast. This fault system extends eastward to the San Andreas Fault (approximately 70 miles from San Diego) and westward to the San Clemente Fault (approximately 50 miles off-shore from San Diego) (Berger and Schug, 1991).

During recent history, the San Diego County area has been relatively quiet seismically. No fault ruptures or major earthquakes have been experienced in historic time within the San Diego area. Since earthquakes have been recorded by instruments (since the 1930s), the San Diego area has experienced scattered seismic events with Richter magnitudes (M) generally less than 4.0. During June 1985, a series of small earthquakes occurred beneath San Diego Bay, three of which had recorded magnitudes of M4.0 to M4.2. In addition, the Oceanside earthquake of July 13, 1986, located approximately 26 miles offshore of the City of Oceanside, had a magnitude of M5.3 (Hauksson and Jones, 1988). On June 15, 2004, a M5.3 earthquake occurred approximately 45 miles southwest of downtown



San Diego (26 miles west of Rosarito, Mexico). Although this earthquake was widely felt, no significant damage was reported.

On Sunday, April 4, 2010, a large earthquake occurred in Baja California, Mexico. It was widely felt throughout the southwest including Phoenix, Arizona and San Diego in California. This M7.2 event, the Sierra El Mayor earthquake, occurred in northern Baja California approximately 40 miles south of the Mexico-USA border at shallow depth along the principal plate boundary between the North American and Pacific plates. According to the U. S. Geological Survey this is an area with a high level of historical seismicity, and it has recently also been seismically active, though this is the largest event to strike in this area since 1892. The April 4, 2010, earthquake appears to have been larger than the M6.9 earthquake in 1940 or any of the early 20th century events (e.g., 1915 and 1934) in this region of northern Baja California. The event caused widespread damage to structures, closure of businesses, government offices and schools, power outages, displacement of people from their homes and injuries in the nearby major metropolitan areas of Mexicali in Mexico and Calexico in southern California. Preliminary estimates of the cost of the damage range to \$100 million.

This event's aftershock zone extends significantly to the northwest, overlapping with the portion of the fault system that is thought to have ruptured in 1892. Some structures in the San Diego area experienced minor damage and there were some injuries. Ground motions for the April 4, 2010, main event, recorded at stations in San Diego and reported by the California Strong Motion Instrumentation Program (CSMIP), ranged up to 0.058g. Aftershocks from this event continue to the date of this report along the trend northwest of the original event, including within San Diego County, closer to the San Diego metropolitan area. There have been hundreds of these earthquakes including events up to M5.7.



In California, major earthquakes can generally be correlated with movement on active faults. As defined by the California Division of Mines and Geology (Hart, E.W., 1980), an "active" fault is one that has had ground surface displacement within Holocene time (about the last 11,000 years). Additionally, faults along which major historical earthquakes have occurred (about the last 210 years in California) are also considered to be active (Association of Engineering Geologist, 1973). The California Division of Mines and Geology defines a "potentially active" fault as one that has had ground surface displacement during Quaternary time, that is, between 11,000 and 1.6 million years (Hart, E.W., 1980).

## **VI. SITE-SPECIFIC GEOLOGIC DESCRIPTION**

### **A. Stratigraphy**

Our reconnaissance, field work, and review of pertinent geologic maps and reports indicate that dense, Tertiary-age Torrey Sandstone (Tt) formational soils underlie the entire site at depth. The encountered soil profile includes fill soil, topsoil/weathered terrace deposits and terrace materials (Qt) overlying the formational soils. Refer to the boring and excavation logs, Figure Nos. IIIa-h. Figure No. V presents a plan view geologic map of the general area of the site.

Fill Soils (Qaf): The lot is overlain by 1 to 3 feet of surficial fill soils encountered at all excavation locations. The fill soils consist of red-brown to dark brown, silty, fine- to medium-grained sand. The fill soils are generally dry to damp, of variable density (loose to medium dense) and low expansion potential, and are not suitable in their current condition for support of loads from new structures or additional fill. Refer to Figure Nos. III and IV for details.



Topsoil/Weathered Terrace Deposits (Qt): The fill soils are underlain by 2 to 3 feet of topsoil/weathered terrace soils consisting of dark brown, silty fine- to medium-grained sand. These soils are generally damp, of variable density and low expansion potential, and are not suitable in their current condition for support of loads from structures or additional fill. Refer to Figure Nos. III and IV for details.

Terrace Deposits (Qt): Pleistocene Marine terrace deposits were encountered below the fill/topsoils and extend to approximately 35 feet in depth at the location of exploratory boring B-1 placed near the northeast corner of the lot. The terrace materials consist of red-brown to tan-brown, silty, fine- to medium-grained sand. The terrace deposits were also observed in the bluff face below the lot and overlying the Torrey Sandstone Formation (Tt). The terrace materials are generally medium dense to dense and moist, and are considered suitable for support of loads from structures or additional fill. Refer to Figure Nos. III and IV for details.

Torrey Sandstone Formation (Tt): The encountered formational materials consist of light tan-brown, fine-to medium-grained sand with some silt. The dense to very dense formational soils were encountered at boring location B-1 at a depth of 35 feet. The formational materials were also observed in the bluff face/sea cliff below the lot. The formational soils are of low expansion potential and have good bearing strength characteristics. Refer to Figure Nos. III and IV for details.

## **B. Structure**

The Tertiary-age Torrey Sandstone Formation (Tt) underlies the site. The Torrey Formation in the lower bluff face strikes N10°E and dips 6 degrees to the east. As shown on the geologic map (refer to Figure No. V, Kennedy and Tan, 2005), Torrey Sandstone bluff exposures reveal strikes from N10°E to N10°W and dips from 2 to



4 degrees to the east at nearby locations. The overlying terrace deposits, including the beach sand facies directly on top of the Torrey Sandstone, appear to be horizontally bedded. The Torrey Sandstone headland, projecting approximately 35 feet seaward from the base of the bluff along the south side of the property, exists due to a N35°E trending fault along its northwest side. The fault dips 83 degrees to the southeast and does not offset the Torrey Sandstone contact with the overlying terrace deposits. Although erosion along the fault has resulted in a minor cave in the bluff face, fault offset has resulted in the relatively stable condition of the lower bluff face north-northwest of the headland by raising a weak bed above the zone of wave attack.

South of the fault a 6-inch-thick mudstone bed exists at elevations commonly subjected to wave attack. As a result, cave formation and localized rapid recession occur south of the fault. North of the fault the Torrey Sandstone has been lifted in elevation as revealed by down-drag folding and 18-degree southerly dips of Torrey Sandstone bedding. The weak mudstone bed has been lifted above the elevation of the Torrey Sandstone-Marine Terrace contact on the northwest side of the fault, and was removed by the marine terrace planation processes. The Torrey Sandstone is exceptionally resistant to erosion and recession below the subject property.

### **C. Bluff Observations**

In general, the coastal bluffs in the Solana Beach area are underlain by two geologic units with significantly different erosion characteristics. The upper bluffs are composed of Pleistocene marine terrace deposits consisting of fine- to medium-grained friable sands with slight cementation on weathered exposures. Iron-oxide cementation of the upper 10 feet results in the materials being only moderately





friable. The deposits are typically stable at their natural angle of repose of approximately 45 degrees. The terrace deposits are particularly susceptible to erosion.

The underlying Torrey Sandstone, which makes up the lower 9 to 10 feet of the bluff or sea cliff, consists primarily of indurated, fine- to medium-grained sand, which weathers and erodes upon exposure along fractures, faults and thin beds of shale material when at the elevation of wave attack. The Torrey Sandstone acts as the primary defense against wave attack, protecting the overlying, friable sandy terrace materials from most direct wave action.

Based on our site observations, it appears that the bluff below the Harris property is approximately 60 to 65 feet high. The upper portion of the upper bluff is approximately 10 feet high and slopes down to the west at a near-vertical inclination. The upper 10 feet is comprised of moderately cemented, reddish brown sandstone. The middle portion of the bluff, below the upper 10 feet, is approximately 40 feet high and at an approximate inclination ranging from 38 to 43 degrees. Most of the middle bluff is comprised of orange-gray to light brown, fine- to medium-grained terrace sand with slight cementation. The lower 10- to 12-foot portion of the middle bluff, however, is comprised of banded light gray and dark gray, cohesionless beach sands. The base of the bluff is comprised of approximately 9 to 10 feet of Torrey Sandstone formational materials. The Torrey sandstone is dense, light tan, fine-to medium-grained and at an overhanging inclination at some locations.

The upper and middle bluff faces are irregular in alignment due to the faulting and jointing of the lower Torrey sandstone bluff which has resulted in a series of small shallow-depth caves. Most of the caves are 2 to 5 feet in width, 3 to 5 feet in



height, and 3 to 8 feet in depth at current beach sand levels, which are approximately 5½ feet below the bottom of the gray and green mudstone bed exposed in the southernmost Torrey Sandstone headland.

The largest fault controlled cave is located on the northwest side of the southern headland. It ranges from 6 inches wide at the beach level, to 4 feet wide approximately 2 feet above the sand elevation. Past episodes of roof collapse have resulted in recession of approximately 10 feet of the lower bluff face. Past recession along the northwest side of the fault has resulted in the headland extending approximately 35 feet to the southwest on the southeast side of the fault.

The approximately 10 feet of recession has resulted in a relatively large mid-bluff bowl configuration bounded on the northwest and southeast sides by mid-bluff ridgelines. At the rim of the upper bluff the bowl comprises approximately 50 feet of the bluff face below the subject property. To the northwest, the mid-bluff bowl transitions to a relatively uniform, planar surface with an inclination of approximately 43 degrees down to the rim of the lower bluff.

The southeast side of the bowl is defined by an upper cemented bluff headland that extends approximately 20 feet westerly of the general rear yard bluff top alignment extending northwest from the headland.

Approximately 50 percent of the bluff face is bare. The remainder of the bluff face is sparsely to moderately covered with large-leaf iceplant and coastal-tolerant shrubs, grasses and weeds. Rilling of the bluff face ranges from approximately 6 to 12 inches in depth. No evidence of recent or active significant erosion or failure processes was observed.



The south property line appears to pass through the nose of the southern headland. Immediately south of the headland, a cave resulting from an approximately 4-foot vertical fault offset has been plugged and is performing well. The cave plug has significantly improved mid-bluff stability at the north end of the adjacent property to the south. The cave plug is believed to be at least 20 years old and displays no significant erosion at the concrete-to-sandstone boundary. A localized 1-foot-deep erosion pocket of limited aerial extent does exist.

***D. Bluff Stability and Recession Mechanisms***

As always with proposed coastal bluff top construction, bluff face geologic stability as well as bluff recession mechanisms and rates are significant factors to be considered in site development. Evaluations must be made of inherent strengths of the Torrey Sandstone and Marine terrace deposits, as well as their highly variable response to coastal erosion processes depending on lithologic variations and degrees of faulting and jointing.

The lower 9 to 10 feet of the bluff face below the subject property stands essentially vertical or sub-vertical due to the erosion resistant nature of the moderately cemented Torrey Sandstone. At some locations, the lower bluff rim overhangs the lower surfaces by 1 to 2 feet. The overlying Marine terrace deposits rise to an elevation of approximately 63 to 65 feet AMSL. Although the upper 10 feet of this unit is often moderately cemented, allowing them to stand at 0.5:1.0 (horizontal to vertical) or steeper, the major portion of the terrace sands or middle bluff are only slightly cemented. Although the low cementation results in slope inclinations of 45 to 50 degrees for the middle bluff along much of the Solana Beach coastline, middle bluff inclinations are shallower below the subject property and



range from 38 to 43 degrees. This is due to the relative stability and low recession rate of the lower Torrey Sandstone.

As part of our evaluation of the bluff recession, we considered a historical bluff recession rate of 0.49 feet per year, which we have used for other properties along the Solana Beach coastline. However, it is our opinion that this section of bluff is much more stable than other areas to the south, and displays lower recession rates on the order of 0.02 to 0.03 feet per year. Review of 1953 aerial photographs show the existing residence in generally the same location, with the bluff edge approximately 15 feet to the west. Review of County of San Diego Topographic Map 302-1683 (based on aerial photography of July 1960) and the Orthophotographic Map dated October 1985, also reveals no detectable bluff edge recession. We suspect offshore bathymetry may also play a role in the localized low bluff recession rate.

Based on current field observations as well as review of historic maps and photographs, it is our opinion that bluff recession of 1 foot or less has occurred in the past 58 years, or 0.017 feet per year.

## **VII. PRELIMINARY BLUFF STABILITY ANALYSES**

Slope stability analysis was performed along two cross sections of the coastal bluff in the area where improvements are proposed. The cross sections are included herein as Figure Nos. VIa-b. Given the site is underlain by medium dense to very dense formational and terrace materials, it is our opinion that sufficient gross stability exists in the building pad area.



As part of geotechnical investigations for adjacent properties and other projects along this portion of the coast in Solana Beach, we have collected similar soil samples of the coastal bluff materials (i.e., the Terrace Deposits and Torrey Sandstone Formation) that exist at the site. We used the soil classification, direct shear tests and standard penetration blow counts from our drilling to assign shear strength values to the soils.

We assigned values of shear strength to the overlying marine terrace materials and the underlying Torrey Sandstone Formation (38.2 degrees internal friction and 600 psf cohesion for the upper terrace, 38.7 degrees and 350 psf for most of the middle terrace, 38 degrees and 100 psf for the lower 10-foot beach sand facies of the middle terrace, and 36 degrees and 3,500 psf for the formational Torrey Sandstone). See attached computer printouts for more information.

Slope stability analysis was performed utilizing a computer program, *GSTABL7 v.2*, which analyzes the factor of safety against shear stresses. Potential shear failure surfaces were analyzed with the assigned soil shear strength values. Shear failure analyses were run along the cross sections depicted on Figure Nos. VIa-b. All potential slide surfaces extending beyond 17 feet on cross section A-A' and 23 feet from the bluff edge on cross section B-B', as presented on Figure Nos. VIa-b, would have a factor of safety of at least 1.5. The failure surface locations were assumed based on boring log information and other information. The minimum acceptable factor of safety against soil shear deep failure is 1.5. Based on our test results, the coastal bluff at the site is considered grossly stable against deep-seated failures. Refer to Appendix F for parameters and results.

Due to low cohesion, shallow or erosional failures may occur on the slope face when the soils become saturated. Minimal irrigation and proper drainage are required.



## **VIII. GEOLOGIC HAZARDS**

The following is a discussion of the geologic conditions and hazards common to this area of Solana Beach, as well as project-specific geologic information relating to development of the subject property.

### **A. Local and Regional Faults**

Rose Canyon Fault: The Rose Canyon Fault Zone (Mount Soledad and Rose Canyon Faults), located approximately 3 miles south and west of the subject site, is mapped trending north-south from Oceanside to downtown San Diego, from where it appears to head southward into San Diego Bay, through Coronado and offshore. The Rose Canyon Fault Zone is considered to be a complex zone of onshore and offshore, en echelon strike slip, oblique reverse, and oblique normal faults. The Rose Canyon Fault is considered to be capable of causing a M7.2 earthquake per the California Geologic Survey (2002) and considered microseismically active, although no significant recent earthquake is known to have occurred on the fault.

Investigative work on faults that are part of the Rose Canyon Fault Zone at the Police Administration and Technical Center in downtown San Diego, at the SDG&E facility in Rose Canyon, and within San Diego Bay and elsewhere within downtown San Diego, has encountered offsets in Holocene (geologically recent) sediments. These findings confirm Holocene displacement on the Rose Canyon Fault, which was designated an "active" fault in November 1991 (California Division of Mines and Geology -- Fault Rupture Hazard Zones in California, 1999).



Newport-Inglewood Fault: The Newport-Inglewood Fault Zone is located approximately 14 miles northwest of the site. A significant earthquake (M6.4) occurred along this fault on March 10, 1933. Since then no additional significant events have occurred. The fault is believed to have a slip rate of approximately 0.6 mm/yr with an unknown recurrence interval. This fault is believed capable of producing an earthquake of M6.0 to M7.4 (SCEC, 2004).

Coronado Bank Fault: The Coronado Bank Fault is located approximately 16.5 miles southwest of the site. Evidence for this fault is based upon geophysical data (acoustic profiles) and the general alignment of epicenters of recorded seismic activity (Greene, 1979). The Oceanside earthquake of M5.3 recorded July 13, 1986, is known to have been centered on the fault or within the Coronado Bank Fault Zone. Although this fault is considered active, due to the seismicity within the fault zone, it is significantly less active seismically than the Elsinore Fault (Hileman, 1973). It is postulated that the Coronado Bank Fault is capable of generating a M7.6 earthquake and is of great interest due to its close proximity to the greater San Diego metropolitan area.

Elsinore Fault: The Elsinore Fault is located approximately 30 to 53 miles east and northeast of the site. The fault extends approximately 200 km (125 miles) from the Mexican border to the northern end of the Santa Ana Mountains. The Elsinore Fault zone is a 1- to 4-mile-wide, northwest-southeast-trending zone of discontinuous and en echelon faults extending through portions of Orange, Riverside, San Diego, and Imperial Counties. Individual faults within the Elsinore Fault Zone range from less than 1 mile to 16 miles in length. The trend, length and geomorphic expression of the Elsinore Fault Zone identify it as being a part of the highly active San Andreas Fault system.



Like the other faults in the San Andreas system, the Elsinore Fault is a transverse fault showing predominantly right-lateral movement. According to Hart, et al. (1979), this movement averages less than 1 centimeter per year. Along most of its length, the Elsinore Fault Zone is marked by a bold topographic expression consisting of linearly aligned ridges, swales and hallows. Faulted Holocene alluvial deposits (believed to be less than 11,000 years old) found along several segments of the fault zone suggest that at least part of the zone is currently active.

Although the Elsinore Fault Zone belongs to the San Andreas set of active, northwest-trending, right-slip faults in the southern California area (Crowell, 1962), it has not been the site of a major earthquake in historic time, other than a M6.0 earthquake near the town of Elsinore in 1910 (Richter, 1958; Topozada and Parke, 1982). However, based on length and evidence of late-Pleistocene or Holocene displacement, Greensfelder (1974) has estimated that the Elsinore Fault Zone is reasonably capable of generating an earthquake as large as M7.5. Study and logging of exposures in trenches placed in Glen Ivy Marsh across the Glen Ivy North Fault (a strand of the Elsinore Fault Zone between Corona and Lake Elsinore), suggest a maximum earthquake recurrence interval of 300 years, and when combined with previous estimates of the long-term horizontal slip rate of 0.8 to 7.0 mm/year, suggest typical earthquakes of M6.0 to M7.0 (Rockwell, 1985). More recently, the California Geologic Survey (2002) considers the Elsinore Fault capable of producing an earthquake of M6.8 to M7.1.

#### ***B. Other Geologic Hazards***

Ground Rupture: Ground rupture is characterized by bedrock slippage along an established fault and may result in displacement of the ground surface. For ground rupture to occur along a fault, an earthquake usually exceeds M5.0. If a M5.0





earthquake were to take place on a local fault, an estimated surface-rupture length 1 mile long could be expected (Greensfelder, 1974). Our investigation indicates that the subject site is not directly on a known fault trace and, therefore, the risk of ground rupture is remote.

Ground Shaking: Structural damage caused by seismically induced ground shaking is a detrimental effect directly related to faulting and earthquake activity. Ground shaking is considered to be the greatest seismic hazard in San Diego County. The intensity of ground shaking is dependent on the magnitude of the earthquake, the distance from the earthquake, and the seismic response characteristics of underlying soils and geologic units. Earthquakes of M5.0 or greater are generally associated with notable to significant damage. It is our opinion that the most serious damage to the site would be caused by a large earthquake originating on a nearby strand of the Rose Canyon Fault Zone. Although the chance of such an event is remote, it could occur within the useful life of the structure. The anticipated ground accelerations from earthquakes on faults within 100 miles of the site are provided in Appendix B. A record of historical earthquakes within a 100-mile radius of the site is provided here as Appendix C. The Modified Mercalli Index is presented as Appendix D.

Landslides: Based upon our geologic reconnaissance, review of the geologic map (Kennedy and Tan, 2005) and aerial photographs (4-11-53, AXN-8M-79 and 80), there are no known or suspected ancient landslides located on the site.

Liquefaction: The liquefaction of saturated sands during earthquakes can be a major cause of damage to buildings. Liquefaction is the process by which soils are transformed into a viscous fluid that will flow as a liquid when unconfined. It occurs



primarily in loose, saturated sands and silts when they are sufficiently shaken by an earthquake.

On this site, the risk of liquefaction of foundation materials due to seismic shaking is considered to be low due to the dense nature of the natural-ground material and the lack of a shallow static groundwater surface under the site. The site does not have a potential for soil strength loss to occur due to a seismic event.

Tsunami: The risk of a tsunami affecting the site is considered low to moderate as the site is situated at an elevation of approximately 65 feet AMSL and in close distance to an exposed beach. In general, the orientation of the southern California coastline and the bathymetry of the offshore southern California borderland have, during historical times, combined to protect the shoreline from any large magnitude tsunami height increases, as shown by records of tsunami occurrences that have been observed and/or recorded along the southern California shoreline since 1810 (Lander et al, 1993). For this segment of the California coastline (south of Santa Monica) there is no evidence of any high magnitude tsunamis generated during the last 200 years by large-scale regional sea floor movements (Gayman, 1998).

Summary: It is our opinion, based upon a review of the available maps and our site investigation, that the site is underlain by stable formational materials, and is suited for the proposed structure additions and associated improvements. It is our opinion that a known "active" fault presents the greatest seismic risk to the subject site during the lifetime of the proposed residence and additions. To date, the nearest known "active" faults to the subject site are the northwest-trending Rose Canyon Fault, Newport-Inglewood Fault, Coronado Bank Fault and the Elsinore Fault. No significant geologic hazards are known to exist on the site that would



prevent the proposed construction. Refer to Section X of this report for seismic design criteria.

## **IX. GROUNDWATER**

No groundwater was encountered during the course of our field investigation and we do not anticipate significant groundwater problems to develop in the future, if the property is developed as proposed and proper drainage is implemented and maintained. Basal bluff seeps common at many locations do not exist below the subject property.

Despite the lack of groundwater evidence, subsurface drainage with a properly designed and constructed subdrain system will be required along with continuous back drainage behind any proposed below-grade walls, property line retaining walls, or any perimeter stem walls for raised-wood floors where the outside grades are higher than the crawl space grades. Furthermore, crawl spaces should be provided with the proper cross-ventilation or mechanical ventilation to help reduce the potential for moisture-related problems.

## **X. CONCLUSIONS AND RECOMMENDATIONS**

The following conclusions and recommendations are based upon the practical field investigation conducted by our firm, and resulting laboratory tests, in conjunction with our knowledge and experience with soil conditions in the Solana Beach area of the County of San Diego.



It is our understanding, based on discussions with Mr. Jim Sneed of Bokal and Sneed Architects, that two options are under consideration for this property. The first option is to demolish the existing residence and construct a new single-family residence. The second option under consideration is to remodel the existing single-story residential structure including the construction of a second-story addition and possible improvement of the existing crawl space for construction of a basement.

Our geotechnical investigation revealed that the lot is underlain by dense to very dense silty sand formational materials and medium dense to dense silty sand terrace deposits. The terrace soils are overlain by approximately 2 to 3 feet of topsoils/weathered terrace soils and 1 to 3 feet of variable density fill soil. In their present condition, these fill soils and topsoils/weathered terrace deposits will not provide a stable base for structure additions and improvements. As such, we recommend that these soils be removed and recompacted as part of site preparation prior to the addition of any new fill or structural improvements. The Marine terrace materials have good bearing strength characteristics and are suitable for support of the proposed structural loads.

Excavation for a basement within or to the east of the existing crawl space should result in the removal of any fill soils/topsoils at the proposed basement location. Any loose or soft soils remaining after the basement excavation subgrade is achieved should be removed and recompacted. All foundations for a new second-story addition should be founded entirely into the underlying medium dense to dense formational terrace materials. In proposed second-story improvement areas, all new building loads must be supported by a caisson system extending below the 1.5 factor of safety theoretical failure surface as defined by our slope stability analysis. As depicted on Figure No. II, the 1.5 factor of safety setback line extends approximately 25 feet into the property from the bluff edge.



Based on our sea cliff recession and slope stability analysis, it is our opinion that the additions can be constructed on conventional and/or deepened foundation systems as long as new loads are borne behind or below the theoretical slope stability surface with a factor of safety of 1.5.

The opinions, conclusions and recommendations presented in this report are contingent upon **Geotechnical Exploration, Inc.** being retained to review the final plans and specifications as they are developed and to observe the site earthwork and installation of foundations.

Section A contains recommendations if demolishing the existing structure and constructing a new single-family residence, Section B contains recommendations if significantly remodeling the existing residence (including basement construction), and Section C contains recommendations applicable to both options.

**A. Option 1: New Construction of Residence**

1. Clearing and Stripping: The existing residence, improvements and vegetation should be removed prior to the preparation of the building pad and areas of associated improvements. This includes any roots from existing trees and shrubbery. Holes resulting from the removal of root systems or other buried foundations, debris or obstructions that extend below the planned grades should be cleared and backfilled with properly compacted fill.
2. Treatment of Existing Fill Soils and/or Loose Surficial Soils: In order to provide suitable foundation support for the new residential structure and associated improvements, we recommend that all existing fill soils that remain after the necessary demolition and site excavations have been made



be removed and recompacted. The recompaction work should consist of (a) removing these soils down to native medium dense materials; (b) scarifying, moisture conditioning, and compacting the exposed natural subgrade soils; and (c) cleaning and replacing the removed material as compacted structural fill. Before any soils are processed our field representative should evaluate the soils at the bottom of the excavation.

The depth required to remove the loose surface soils is anticipated to be approximately 1 to 6 feet but should be confirmed by our representatives during the excavation work based on their examination of the soils being exposed. The lateral extent of the excavation and recompaction should be at least 5 feet beyond the edge of the perimeter foundations of the residential structure and any areas to receive exterior improvements where feasible.

Any unsuitable materials (such as oversize rubble, highly expansive clayey soils, and/or organic matter) should be selectively removed as indicated by our representative and disposed of off-site.

Any rigid improvements founded on the existing variable density surface soils can be expected to undergo movement and possible damage. **Geotechnical Exploration, Inc.** takes no responsibility for the performance of any improvements built on loose natural soils or inadequately compacted fills. Any exterior area to receive concrete improvements should be verified for compaction and moisture within 48 hours prior to concrete placement or during the fill placement if the thickness of fill exceeds 1 foot.



3. Subgrade Preparation: After the site has been cleared, stripped, and the required excavations made, the exposed subgrade soils in areas to receive fill and/or building improvements should be scarified to a depth of 6 inches, moisture conditioned, and compacted to the requirements for structural fill. Moisture content should be maintained by periodical sprinkling until within 48 hours prior to concrete placement.
  
4. Expansive Soil Conditions: We do not anticipate that significant quantities of medium or highly expansive clay soils will be encountered during grading. Should such soils be encountered and used as fill, however, they should be moisture conditioned to at least 5 percent above optimum moisture content, compacted to 88 to 92 percent, and placed outside building areas. Soils of medium or greater expansion potential should not be used as retaining wall backfill soils.
  
5. Material for Fill: Existing on-site soils with an organic content of less than 3 percent by volume are, in general, suitable for use as fill. Any required imported fill material should be a low-expansion potential (Expansion Index of 50 or less per ASTM D4829-07). In addition, both imported and existing on-site materials for use as fill should not contain rocks or lumps more than 3 inches in greatest dimension. All materials for use as fill should be approved by our representative prior to importing to the site.
  
6. Fill Compaction: All structural fill should be compacted to a minimum degree of compaction of 90 percent based upon ASTM D1557-09. Fill material should be spread and compacted in uniform horizontal lifts not exceeding 8 inches in uncompacted thickness. Before compaction begins, the fill should be brought to a water content that will permit proper compaction by either:



8. Footings: We recommend that the proposed new residence be supported on conventional, individual-spread and/or continuous footing foundations bearing on recompacted fill soils prepared as stated above and/or undisturbed natural material. All footings should be founded at least 18 inches below the lowest adjacent finished grade.

If the proposed footings are located closer than 8 feet inside the top or face of slopes, they should be deepened to 1½ feet below a line beginning at a point 8 feet horizontally inside the slopes and projected outward and downward, parallel to the face of the slope and into firm soils. Footings located adjacent to utility trenches should have their bearing surfaces situated below an imaginary 1.5:1.0 plane projected upward from the bottom edge of the adjacent utility trench.

9. Bearing Values: At the recommended depths, footings on compacted fill or native soil may be designed for allowable bearing pressures of 2,500 pounds per square foot (psf) for combined dead and live loads and 3,300 psf for all loads, including wind or seismic. The footings should, however, have a minimum depth of 18 inches and a minimum width of 12 inches for one-story structures and 15 inches for two-story structures. Footing excavations should be evaluated by our representative prior to steel and form placement.
10. Footing Reinforcement: All continuous footings should contain top and bottom reinforcement to provide structural continuity and to permit spanning of local irregularities. We recommend that a minimum of two No. 5 top and two No. 5 bottom reinforcing bars be provided in the footings. A minimum clearance of 3 inches should be maintained between steel reinforcement and the bottom or sides of the footing. Isolated square footings should contain,





as a minimum, a grid of three No. 4 steel bars on 12-inch centers, both ways. In order for us to offer an opinion as to whether the footings are founded on soils of sufficient load bearing capacity, it is essential that our representative inspect the footing excavations prior to the placement of reinforcing steel or concrete.

*NOTE: The project Civil/Structural Engineer should review all reinforcing schedules. The reinforcing minimums recommended herein are not to be construed as structural designs, but merely as minimum reinforcement to reduce the potential for cracking and separations.*

11. Lateral Loads: Lateral load resistance for the structures supported on footing foundations may be developed in friction between the foundation bottoms and the supporting subgrade. An allowable friction coefficient of 0.40 is considered applicable. An additional allowable passive resistance equal to an equivalent fluid weight of 300 pounds per cubic foot acting against the foundations may be used in design provided the footings are poured neat against the adjacent undisturbed formational materials and/or properly compacted fill materials. These lateral resistance values assume a level surface in front of the footing for a minimum distance of three times the embedment depth of the footing.
  
12. Settlement: Settlements under building loads are expected to be within tolerable limits for the proposed residence. For footings designed in accordance with the recommendations presented in the preceding paragraphs, we anticipate that total settlements should not exceed 1 inch and that post-construction differential angular rotation should be less than 1/2-inch in 25 feet.



**B. Option 2: Remodel of Existing Residence with Second-story Addition and Possible Basement Construction**

13. Clearing and Stripping: Loose surficial soils in yard areas as well as existing foundation supports and loose surficial soils at locations within the crawl space intended to receive new support systems should be removed to expose adequate bearing materials. Holes resulting from the removal of existing foundations, debris or obstructions that extend below the planned grades should be cleaned and backfilled with properly compacted fill.

14. Treatment of Existing Fill Soils and/or Loose Surficial Soils: We anticipate that undisturbed topsoil/weathered terrace materials may be encountered at the bottom of the basement or foundation excavations. In order to provide suitable foundation support for the proposed structure and associated improvements, we recommend that all existing fill soils that remain after the necessary demolition and site excavations have been made be removed and recompacted. The recompaction work should consist of (a) removing these soils down to native medium dense terrace formational materials; (b) scarifying, moisture conditioning, and compacting the exposed natural subgrade soils; and (c) cleaning and replacing the removed material as compacted structural fill. Before any soils are processed our field representative should evaluate the soils at the bottom of the excavation.

14.1 The depth required to remove the fill soils is anticipated to range from 3 to 4 feet but should be confirmed by our representatives during the excavation work based on the examination of the soils being exposed. If deeper surficial soils are encountered, the footings supporting a structural slab may be deepened as necessary to extend down to



undisturbed natural material. New foundations will have to remain within the existing building footprint or outside of the 25-foot setback and cantilever beyond the setback line if outside the existing footprint. The contractor should follow Cal-OSHA safety guidelines during construction.

- 14.2 Any unsuitable materials (such as oversize rubble, highly expansive clayey soils, and/or organic matter) should be selectively removed as indicated by our representative and disposed of off-site.
- 14.3 Any rigid improvements founded on the existing variable density surface soils can be expected to undergo movement and possible damage. ***Geotechnical Exploration, Inc.*** takes no responsibility for the performance of any improvements built on loose natural soils or inadequately compacted fills. Any exterior area to receive concrete improvements should be verified for compaction and moisture within 48 hours prior to concrete placement or during the fill placement if the thickness of fill exceeds 1 foot.
- 14.4 Temporary shoring or bracing may be needed if areas of proposed cuts are in loose or low cohesion soils and the recommended temporary slopes cannot be achieved due to space constraints, or if existing adjacent improvements surcharge the top of temporary cuts.
15. *Exterior Subgrade Preparation:* After the proposed addition areas of the site have been cleared, stripped, and the required excavations made, the exposed subgrade soils in areas to receive fill and/or building improvements should be scarified to a depth of 6 inches, moisture conditioned, and



compacted to the requirements for structural fill. Moisture content should be maintained by periodic sprinkling until within 48 hours prior to concrete placement. Excavation into dense formational terrace soils should not need scarification or recompaction.

16. Expansive Soil Conditions: We do not anticipate that significant quantities of medium or highly expansive clay soils will be encountered during grading. Should such soils be encountered and used as fill, however, they should be moisture conditioned to at least 5 percent above optimum moisture content, compacted to 88 to 92 percent, and placed outside building areas. Soils of medium or greater expansion potential should not be used as retaining wall backfill soils.
  
17. Material for Fill: Existing on-site soils with an organic content of less than 3 percent by volume are, in general, suitable for use as fill. Any required imported fill material should be a low-expansion potential (Expansion Index of 50 or less per ASTM D4829-07). In addition, both imported and existing on-site materials for use as fill should not contain rocks or lumps more than 6 inches in greatest dimension if the fill soils are compacted with heavy compaction equipment (or 3 inches in greatest dimension if compacted with lightweight equipment). All materials for use as fill should be approved by our representative prior to importing to the site.
  
18. Fill Compaction: All structural fill should be compacted to a minimum degree of compaction of 90 percent based upon ASTM D1557-09. Fill material should be spread and compacted in uniform horizontal lifts not exceeding 8 inches in uncompacted thickness. Before compaction begins, the fill should be brought to a water content that will permit proper compaction by either:



(1) aerating and drying the fill if it is too wet, or (2) moistening the fill with water if it is too dry. Each lift should be thoroughly mixed before compaction to ensure a uniform distribution of moisture.

No uncontrolled fill soils should remain after completion of the site work. In the event that temporary ramps or pads are constructed of uncontrolled fill soils, the loose fill soils should be removed and/or recompacted prior to completion of the grading operation.

19. Trench and Basement Wall Backfill: Utility trenches and the basement walls should preferably be backfilled with compacted fill; gravel is also a suitable backfill material but should be used only if space constraints will not allow the use of compaction equipment. Gravel can also be used as backfill around perforated subdrains. Backfill material should be placed in lift thicknesses appropriate to the type of compaction equipment utilized and compacted to a minimum degree of compaction of 90 percent by mechanical means.

Our experience has shown that even shallow, narrow trenches (such as for irrigation and electrical lines) that are not properly compacted can result in problems, particularly with respect to shallow groundwater accumulation and migration.

Backfill soils placed behind retaining walls and/or crawl space retaining walls should be installed as early as the retaining walls are capable of supporting lateral loads. Backfill soils should be low expansive, with an Expansion Index equal to or lower than 50.



20. Footings: We recommend that the basement addition or new second-story addition be supported on conventional, individual-spread and/or continuous footing foundations founded at least 18 inches into medium dense to dense formational terrace materials. Footings located adjacent to utility trenches should have their bearing surfaces situated below an imaginary 1.5:1.0 plane projected upward from the bottom edge of the adjacent utility trench.
  
21. Bearing Values: At the recommended depths, footings on compacted fill or formational soil may be designed for allowable bearing pressures of 2,500 pounds per square foot (psf) for combined dead and live loads and 3,300 psf for all loads, including wind or seismic. However, the footings should have a minimum width of 12 inches.
  
22. Footing Reinforcement: All continuous footings should contain top and bottom reinforcement to provide structural continuity and to permit spanning of local irregularities. We recommend that a minimum of two No. 5 top and two No. 5 bottom reinforcing bars be provided in the footings. A minimum clearance of 3 inches should be maintained between steel reinforcement and the bottom or sides of the footing. Isolated square footings should contain, as a minimum, a grid of three No. 4 steel bars on 12-inch centers, both ways. In order for us to offer an opinion as to whether the footings are founded on soils of sufficient load bearing capacity, it is essential that our representative inspect the footing excavations prior to the placement of reinforcing steel or concrete.



*NOTE: The project Civil/Structural Engineer should review all reinforcing schedules. The reinforcing minimums recommended herein are not to be construed as structural designs, but merely as minimum reinforcement to reduce the potential for cracking and separations.*

23. Lateral Loads: Lateral load resistance for the structure supported on footing foundations may be developed in friction between the foundation bottoms and the supporting subgrade. An allowable friction coefficient of 0.40 is considered applicable. An additional allowable passive resistance equal to an equivalent fluid weight of 300 pounds per cubic foot acting against the foundations may be used in design provided the footings are poured neat against the adjacent undisturbed formational materials and/or properly compacted fill materials. These lateral resistance values assume a level surface in front of the footing for a minimum distance of three times the embedment depth of the footing.
24. Settlement: Settlements under building loads are expected to be within tolerable limits for the remodeled residence. For footings designed in accordance with the recommendations presented in the preceding paragraphs, we anticipate that total settlements should not exceed 1 inch and that post-construction differential angular rotation should be less than 1/240.
25. Setback Distance: Based on our slope stability analysis, the 1.5 factor of safety bluff top setback extends approximately 25 feet into the building pad east of the bluff edge. All new addition areas, except for the basement, must either be located behind the setback line or be founded on vertical support systems that extend through the theoretical 1.5 factor of safety planar



surface and are designed to accommodate all vertical and lateral loading. The required setback for new additions is 25 feet from the existing bluff edge.

26. Upper-story Addition Footings: If new loads are proposed to bear on the existing foundation, the foundation size should be verified as having adequate bearing foundation area. The adequate sizing of the foundation should be based on the allowable soil bearing capacity discussed in the following paragraph. Allowable bearing for existing soils and foundations is 1,000 psf.

27. New Grade Beam Footings: It is recommended that grade beam footings supported on shallow piers/caissons be utilized adjacent to and/or under the existing footings where additional loads are anticipated or where the new second-story additions are to be built on deep foundations. In addition, if loose surficial soils are not properly recompacted, any new lateral structure additions should also be supported on grade beam footings supported on piers. The following design minimums apply:

27.1 The grade beam footings should extend a minimum of 24 inches below the lowest adjacent grade. Additionally, the grade beam footing should underlie at least one-half the width of existing footings when used for underpinning, and be dowelled into them. The stem wall portion of the grade beam footing that will essentially face the existing footing along the exterior should be at least 8 inches in thickness.





27.2 Minimum reinforcement for grade beam footings should include at least four No. 5 bars. A minimum clearance of 3 inches should be maintained between steel reinforcement and the bottom or sides of the footing. In order for us to offer an opinion as to whether the footings are founded on soils of sufficient load bearing capacity, it is essential that our representative inspect the footing excavations prior to the placement of reinforcing steel or concrete.

27.3 The stem portion of the grade beam footing should be doweled into the existing footing as specified by the structural engineer. Excavations for grade beam footings may be done in alternating 8-foot-wide slots or proper sacrificial jack support should be provided by the contractor to prevent settlement of existing footings during grade beam footing construction. Another option is underpinning the existing footings with concrete piers separated by the distance the existing footing can safely span (estimated at 6 feet) as recommended by the design structural engineer taking into consideration the existing footing dimensions. The pier dimensions should consider the recommended allowable bearing capacity. The steel reinforcing and connections between the existing footing and new bearing piers should be provided by the structural engineer.

*NOTE: The project Civil/Structural Engineer should provide all reinforcing schedules. The reinforcing minimums recommended herein are not to be construed as structural designs, but merely as minimum reinforcement to reduce the potential for cracking and separations.*



28. Pier/Caisson Design: Where piers/caissons are utilized, they should be designed by the project Civil/Structural Engineer to support all vertical and lateral loads of the proposed additions. Should portions of the additions be cantilevered to meet bluff edge setback and theoretical failure surface criteria, the pier/caisson system should be designed to support the cantilevered loading. Refer to Figure No. VII for a schematic depiction of pier/caisson embedment.

The pier/caisson capacity should be based on an allowable shaft frictional resistance of 700 psf starting at a depth of 10 feet below the ground surface. The pier/caisson weight to be considered in the calculation is 40 pcf for the buried part of the pier/caisson.

29. Pier/Caisson Spacing: The minimum center-to-center spacing of piers, in a direction perpendicular to the lateral load, should be 3 pier diameters. For piers located in the same line of the applied lateral load, the shadow effect produces a reducing effect in their combined individual lateral load capacity. For piers spaced 3B feet center-to-center (B=pier diameter), the reduction factor should be equal to 3 for the sum of the individual capacities. Group reduction factors are 3.0, 2.6, 2.2, 1.8, 1.4 and 1.0 for caisson spacings of 3B, 4B, 5B, 6B, 7B and 8B, respectively.

30. Lateral Resistance: If a balance of forces is calculated based on the applied lateral forces and reaction soil forces, the following allowable passive (equivalent fluid) forces are recommended: 150 pcf for existing fill and topsoils, and 300 pcf for formational soils and properly recompacted fills. The passive resistance should be measured from a depth of piers at least 5 feet below the surface in a horizontal pad and within 10 feet minimum



distance to daylight. The passive resistance of the piers may be considered applicable on a projected surface equal to 2.5 times the diameter of the pier multiplied by the vertical length being considered.

31. Pier/Caisson Excavation Observations: Caisson drilling operations should be performed under the continual observation of a representative of our firm to confirm penetration into formational soils and specified embedment.
32. Pier/Caisson Design Standards: The design and construction of the piers/caissons should be in accordance with the recommendations presented above, the current UBC requirements accepted by the City of San Diego, and also in accordance with ACI 336, 3R-93 Design and Construction of Drilled Piers, of the American Concrete Institute. The contractor shall follow all the safety procedures required by Cal OSHA.
33. Filling of Pier/Caisson Excavations: It is recommended that the pier excavations be filled with concrete within 2 days after the excavations are completed, to help reduce the risk of soil caving, mud or slough intrusion, etc. Slough material filling the bottom of drilled holes shall be removed prior to concrete placement. If caving occurs while drilling piers, shoring should be used. Shoring may be removed while placing concrete.

**C. Recommendations for Both Options #1 and #2**

34. Seismic Data Bases: An estimation of the peak ground acceleration and the repeatable high ground acceleration (RHGA) likely to occur at the project site based on the known significant local and regional faults within 100 miles of the site is included as Appendix B. In addition, a listing of the known historic



seismic events that have occurred within 100 miles of the site at a magnitude of M5.0 or greater since the year 1800, and the probability of exceeding the experienced ground accelerations in the future based upon the historical record, is provided in Appendix C. Both Appendix B and Appendix C are tables generated from computer programs EQFault and EQSearch by Thomas F. Blake (2000) utilizing a digitized file of late-Quaternary California faults (EQFault) and a file listing of recorded earthquakes (EQSearch). Estimations of site intensity are also provided in these listings as Modified Mercalli Index values. The Modified Mercalli Intensity Index is provided as Appendix D.

35. Seismic Design Criteria: We have determined the mapped spectral acceleration values for the site based on a latitude of 32.9996 degrees and longitude of 117.2766 degrees, utilizing a program titled "Seismic Hazard Curves, Response Parameters and Design Parameters-v5.0.8," provided by the USGS, which provides a solution for ASCE 7-10 (Section 1613 of the 2010 CBC) utilizing digitized files for the Spectral Acceleration maps. In addition, we have assigned a Site Classification of  $S_D$ . The response parameters for design are presented in the following table. The design spectrum acceleration vs. Period T is shown on Appendix E.

**TABLE I**  
**Mapped Spectral Acceleration Values and Design Parameters**

$S_s$	$S_1$	$F_a$	$F_v$	$S_{ms}$	$S_{m1}$	$S_{ds}$	$S_{d1}$
1.453	0.554	1.0	1.5	1.453	0.832	0.968	0.554

36. Minimum Floor Slab Reinforcement: Based on our experience, we have found that, for various reasons, floor slabs occasionally crack, causing brittle surfaces such as ceramic tiles to become damaged. Therefore, we



recommend that all slabs on-grade contain at least a minimum amount of reinforcing steel to reduce the separation of cracks, should they occur.

- 36.1 Any interior floor slabs should be a minimum of 4 inches actual thickness and be reinforced with No. 3 bars on 15-inch centers, both ways, placed at midheight in the slab. *The slabs should be underlain by a 2-inch-thick layer of clean sand (S.E. = 30 or greater) overlying a moisture retardant membrane over 2 inches of sand.* Slab subgrade soil should be verified by a **Geotechnical Exploration, Inc.** representative to have the proper moisture content within 48 hours prior to placement of the vapor barrier and pouring of concrete. Slabs spanning between grade beams should be designed as structural slabs.
- 36.2 Preferably, below-grade slabs should be provided with a waterproofing membrane such as Paraseal on a 4-inch gravel base placed on properly compacted subgrade, per the manufacturer's instructions. The owner should be consulted as to the degree of slab moisture protection desired. If perched groundwater or seeps are observed after the basement excavation is complete, a subdrain drainage system may need to be installed beneath the slab.
- 36.3 Following placement of any concrete floor slabs, sufficient drying time must be allowed prior to placement of floor coverings. Premature placement of floor coverings may result in degradation of adhesive materials and loosening of the finish floor materials.



37. Concrete Isolation Joints: We recommend the project Civil/Structural Engineer incorporate isolation joints and sawcuts to at least one-fourth the thickness of the slab in any floor designs. The joints and cuts, if properly placed, should reduce the potential for and help control floor slab cracking. We recommend that concrete shrinkage joints be spaced no farther than approximately 20 feet apart, and also at re-entrant corners. However, due to a number of reasons (such as base preparation, construction techniques, curing procedures, and normal shrinkage of concrete), some cracking of slabs can be expected. Structural slabs should not be provided with control joints.
38. Slab Moisture Emission: Although it is not the responsibility of geotechnical engineering firms to provide moisture protection recommendations, as a service to our clients we provide the following discussion and suggested minimum protection criteria. Actual recommendations should be provided by the architect and waterproofing consultants. Soil moisture vapor can result in damage to moisture-sensitive floors, some floor sealers, or sensitive equipment in direct contact with the floor, in addition to mold and staining on slabs, walls and carpets.

The common practice in Southern California is to place vapor retarders made of PVC, or of polyethylene. PVC retarders are made in thicknesses ranging from 10- to 60-mil. Polyethylene retarders called visqueen range from 5- to 10-mil in thickness. These products are no longer considered adequate for moisture protection and can actually deteriorate over time.



Specialty vapor retarding and barrier products possess higher tensile strength and are more specifically designed for and intended to retard moisture transmission into and through concrete slabs. The use of such products is highly recommended for reduction of floor slab moisture emission.

38.1 The following American Society for Testing and Materials (ASTM) and American Concrete Institute (ACI) sections address the issue of moisture transmission into and through concrete slabs: ASTM E1745-97 (2009) Standard Specification for Plastic Water Vapor Retarders Used in Contact Concrete Slabs; ASTM E154-88 (2005) Standard Test Methods for Water Vapor Retarders Used in Contact with Earth; ASTM E96-95 Standard Test Methods for Water Vapor Transmission of Materials; ASTM E1643-98 (2009) Standard Practice for Installation of Water Vapor Retarders Used in Contact Under Concrete Slabs; and ACI 302.2R-06 Guide for Concrete Slabs that Receive Moisture-Sensitive Flooring Materials.

38.2 Based on the above, we recommend that the vapor barrier consist of a minimum 15-mil extruded polyolefin plastic (no recycled content or woven materials permitted). Permeance as tested before and after mandatory conditioning (ASTM E1745 Section 7.1 and sub-paragraphs 7.1.1-7.1.5) should be less than 0.01 perms (grains/square foot/hour in Hg) and comply with the ASTM E1745 Class A requirements. Installation of vapor barriers should be in accordance with ASTM E1643. The basis of design is Stegowrap vapor barrier 15-mil.



- 38.3 Common to all acceptable products, vapor retarder/barrier joints must be lapped and sealed with mastic or the manufacturer's recommended tape or sealing products. In actual practice, stakes are often driven through the retarder material, equipment is dragged or rolled across the retarder, overlapping or jointing is not properly implemented, etc. All these construction deficiencies reduce the retarder's effectiveness. In no case should retarder/barrier products be punctured or gaps be allowed to form prior to or during concrete placement.
- 38.4 Vapor retarders/barriers do not provide full waterproofing for structures constructed below free water surfaces. They are intended to help reduce or prevent vapor transmission and/or capillary migration through the soil and through the concrete slabs. Waterproofing systems must be designed and properly constructed if full waterproofing is desired. The owner and project designers should be consulted to determine the specific level of protection required.
39. Exterior Slab Reinforcement: As a minimum for protection of on-site improvements, we recommend that all nonstructural concrete slabs (such as patios, sidewalks, etc.) be at least 4 inches in actual thickness, founded on properly compacted and tested fill or dense native formation and underlain by no more than 3 inches of clean leveling sand, with No. 3 bars at 18-inch centers, both ways, at the center of the slab, and contain adequate isolation and control joints.

The performance of on-site improvements can be greatly affected by soil base preparation and the quality of construction. It is therefore important that all improvements are properly designed and constructed for the existing





soil conditions. The improvements should not be built on loose soils or fills placed without our observation and testing. The subgrade of exterior improvements should be verified as properly prepared within 48 hours prior to concrete placement.

For exterior slabs with the minimum shrinkage reinforcement, control joints should be placed at spaces no farther than 15 feet apart or the width of the slab, whichever is less, and also at re-entrant corners. Control and isolation joints in exterior slabs should be sealed with elastomeric joint sealant. The sealant should be inspected every 6 months and be properly maintained.

40. Slope Observations: A representative of **Geotechnical Exploration, Inc.** must observe any steep temporary slopes *during construction*. In the event that soils and formational material comprising a slope are not as anticipated, any required slope design changes would be presented at that time.
  
41. Temporary Slopes: Temporary slopes (if excavated for basement construction) should be stable for a maximum slope height of 12 feet in medium dense to dense formational terrace soils at a ratio of 1.0:1.0 (horizontal to vertical). No soil stockpiles, improvements or other surcharges may exist or be placed within a horizontal distance of 10 feet from the excavation. If these recommendations are not feasible due to space constraints, temporary shoring i.e., soldier pile and lagging, may be required for safety and to protect adjacent property improvements and construction personnel. Temporary shoring if needed, i.e., soldier pile and lagging, should be designed as recommended in this report. This office should be contacted for additional recommendations if additional shoring or steep temporary slopes are required.



42. Cal-OSHA Guidelines: Where not superseded by specific recommendations presented in this report, trenches, excavations and temporary slopes at the subject site should be constructed in accordance with Title 8, Construction Safety Orders, issued by Cal-OSHA.
43. Design Parameters – Unrestrained Retaining Walls: The active earth pressure (to be utilized in the design of any cantilever retaining walls, utilizing on-site or imported very low- to low-expansive soils [EI less than 50] as backfill) should be based on an Equivalent Fluid Weight of 35 pounds per cubic foot (for level backfill only). In the event that a retaining wall is surcharged by sloping backfill, the design active earth pressure should be based on the appropriate Equivalent Fluid Weight presented in the following table.

Slope Ratio	Height of Slope/Height of Wall*			
	0.25	0.50	0.75	1.00(+)
<b>2.0:1.0 (proposed slope)</b>	42	48	50	52

\*To determine design active earth pressures for ratios intermediate to those presented, interpolate between the stated values.

44. Design Parameters – Restrained Retaining Walls: Retaining walls designed for a restrained condition should utilize a uniform pressure equal to 9xH (nine times the total height of retained soil, considered in pounds per square foot) considered as acting everywhere on the back of the wall **in addition to the design Equivalent Fluid Weight.** The soil pressure produced by any footings, improvements, or any other surcharge placed within a horizontal distance equal to the height of the retaining portion of the wall should be included in the wall design pressure. The recommended lateral soil pressures



are based on the assumption that no loose soils or soil wedges will be retained by the retaining wall.

Backfill soils should consist of low-expansive soils with EI less than 50, and should be placed from the heel of the foundation to the ground surface within the wedge formed by a plane at 30° from vertical, and passing by the heel of the foundation and the back face of the retaining wall. A soil at-rest pressure of 52 pcf may be used for a restrained shoring wall if level soil is retained. If top-of-wall rotation is allowed, the soil equivalent fluid weight of 35 pcf may be used. Surcharge loads should be considered when applicable for the shoring design.

Shoring pressures may be calculated for soldier pile and lagging based on the unrestrained or restrained soil parameters described previously. Passive resistance of soldier piles may be considered equal to 700 pcf applied in the embedded depth (times 1 diameter) below the grade beam or foundation bottom elevation.

45. Surcharge Loads: Any loads placed on the active wedge behind a cantilever wall should be included in the design by multiplying the load weight by a factor of 0.30. For a restrained wall, the lateral factor should be 0.44.
46. Wall Drainage: Proper subdrains and free-draining backwall material or board drains (such as J-drain or Miradrain) should be installed behind all retaining walls (in addition to proper waterproofing) on the subject project (see Figure No. VIII for Retaining Wall Backdrain and Waterproofing Schematic). **Geotechnical Exploration, Inc.** will assume no liability for damage to structures or improvements that is attributable to poor drainage.



The architectural plans should clearly indicate that subdrains for any lower-level walls be placed at an elevation at least 1 foot below the bottom of the lower-level slabs. At least 0.5-percent gradient should be provided to the subdrain. The subdrain should be placed in an envelope of crushed rock gravel up to 1 inch in maximum diameter, and be wrapped with Mirafi 140N geofabric or equivalent. The subdrain should consist of Amerdrain or QuickDrain (rectangular section boards). If the slab is to be supported on top of basement wall footings, then the subdrain should be placed on the outer face of the footing, not on top of the footing.

47. Drainage Quality Control: It must be understood that it is not within the scope of our services to provide quality control oversight for surface or subsurface drainage construction or retaining wall sealing and base of wall drain construction. It is the responsibility of the contractor and/or their retained construction inspection service provider to verify proper wall sealing, geofabric installation, protection board (if needed), drain depth below interior floor or yard surface, pipe percent slope to the outlet, etc.
48. Surface Drainage: Adequate measures should be taken to properly finish-grade the lot after the residence additions and other improvements are in place. ***In no case should surface drainage water be allowed to flow toward and over the bluff edge.*** Drainage waters from this site and adjacent properties should be directed away from the footings, floor slabs, and slopes, and into properly designed and approved drainage facilities provided by the project civil engineer. Roof gutters and downspouts should be installed on the residence and additions, with the runoff directed away from the foundations via closed drainage lines.



Proper subsurface and surface drainage will help minimize the potential for waters to seek the level of the bearing soils under the footings and floor slabs. Failure to observe this recommendation could result in undermining and possible differential settlement of the structure or other improvements or cause other moisture-related problems. Currently, the Uniform Building Code requires a minimum 2-percent surface gradient for proper drainage of building pads unless waived by the building official. Concrete pavement may have a minimum gradient of 0.5-percent.

49. Erosion Control: Appropriate erosion control measures should be taken at all times during and after construction to prevent surface runoff waters from entering footing excavations or ponding on finished building pad areas or runoff on the slope face from the building pad.
50. Planter Drainage: Planter areas, flower beds and planter boxes should be sloped to drain away from the footings and floor slabs at a gradient of at least 5 percent within 5 feet from the perimeter walls. Any planter areas adjacent to the residence or surrounded by concrete improvements should be provided with sufficient area drains to help with rapid runoff disposal. No water should be allowed to pond adjacent to the residence or other improvements.
51. Project Start Up Notification: In order to reduce any work delays during site development, this firm should be contacted at least 48 hours and preferably 48 hours prior to any need for observation of footing excavations or field density testing of compacted fill soils. If possible, placement of formwork and steel reinforcement in footing excavations should not occur prior to observing the excavations; in the event that our observations reveal the



need for deepening or redesigning foundation structures at any locations, any formwork or steel reinforcement in the affected footing excavation areas would have to be removed prior to correction of the observed problem (i.e., deepening the footing excavation, recompacting soil in the bottom of the excavation, etc.).

52. Construction Best Management Practices (BMPs): Construction BMPs must be implemented in accordance with the requirements of the controlling jurisdiction. Sufficient BMPs must be installed to prevent silt, mud or other construction debris from being tracked into the adjacent street(s) or storm water conveyance systems due to construction vehicles or any other construction activity. The contractor is responsible for cleaning any such debris that may be in the street at the end of each work day or after a storm event that causes breach in the installed construction BMPs.

All stockpiles of uncompacted soil and/or building materials that are intended to be left unprotected for a period greater than 7 days are to be provided with erosion and sediment controls. Such soil must be protected each day when the probability of rain is 40% or greater. A concrete washout should be provided on all projects that propose the construction of any concrete improvements that are to be poured in place. All erosion/sediment control devices should be maintained in working order at all times. All slopes that are created or disturbed by construction activity must be protected against erosion and sediment transport at all times. The storage of all construction materials and equipment must be protected against any potential release of pollutants into the environment.



## **XI. GRADING NOTES**

**Geotechnical Exploration, Inc.** recommends that we be retained to verify the actual soil conditions revealed during site grading work and footing excavation to be as anticipated in this "*Report of Limited Geotechnical Investigation and Coastal Bluff Stability Evaluation*" for the project. In addition, the compaction of any fill soils placed during site grading work must be observed and tested by the soil engineer. It is the responsibility of the grading contractor to comply with the requirements on the grading plans and the local grading ordinance. All retaining wall and trench backfill should be properly compacted. **Geotechnical Exploration, Inc.** will assume no liability for damage occurring due to improperly or uncompacted backfill placed without our observations and testing.

## **XII. LIMITATIONS**

Our conclusions and recommendations have been based on available data obtained from our field investigation and laboratory analysis, as well as our experience with similar soils and formational materials located in this area of San Diego County. Of necessity, we must assume a certain degree of continuity between exploratory excavations and/or natural exposures. It is, therefore, necessary that all observations, conclusions, and recommendations be verified at the time grading operations begin or when footing excavations are placed. In the event discrepancies are noted, additional recommendations may be issued, if required.

The work performed and recommendations presented herein are the result of an investigation and analysis that meet the contemporary standard of care in our profession within the County of San Diego. No warranty is provided.



As stated previously, it is not within the scope of our services to provide quality control oversight for surface or subsurface drainage construction or retaining wall sealing and base of wall drain construction. It is the responsibility of the contractor and/or their retained construction inspection service provider to verify proper wall sealing, geofabric installation, protection board installation (if needed), drain depth below interior floor or yard surfaces; pipe percent slope to the outlet, etc.

This report should be considered valid for a period of two (2) years, and is subject to review by our firm following that time. If significant modifications are made to the building plans, especially with respect to the height and location of any proposed structures, this report must be presented to us for immediate review and possible revision.

It is the responsibility of the owner and/or developer to ensure that the recommendations summarized in this report are carried out in the field operations and that our recommendations for design of this project are incorporated in the structural plans. Our firm should be retained to review the project plans once they are available to verify that our recommendations are adequately incorporated.

This firm does not practice or consult in the field of safety engineering. We do not direct the contractor's operations and we cannot be responsible for the safety of personnel other than our own; the safety of others is the responsibility of the contractor. The contractor should notify the owner if any of the recommended actions presented in this report are considered to be unsafe.

The firm of **Geotechnical Exploration, Inc.** shall not be held responsible for changes to the physical condition of the property, such as addition of fill soils or





changing drainage patterns, which occur subsequent to issuance of this report and the changes are made without our observations, testing, and approval.

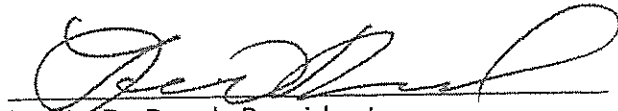
Once again, should any questions arise concerning this report, please feel free to contact the undersigned. Reference to our **Job No. 11-10035** will expedite a reply to your inquiries.

Respectfully submitted,


**GEOTECHNICAL EXPLORATION, INC.**



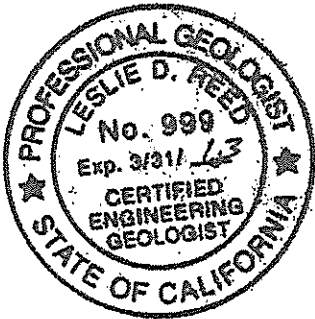
Jay K. Heiser  
Senior Project Geologist



Leslie D. Reed, President  
C.E.G. 999[exp. 3-31-13]/R.G. 3391



Jaime A. Cerros, P.E.  
R.C.E. 34422/G.E. 2007  
Senior Geotechnical Engineer



**REFERENCES**  
JOB NO. 11-10035  
July 2011

Association of Engineering Geologists, 1973, Geology and Earthquake Hazards, Planners Guide to the Seismic Safety Element, Southern California Section, Association of Engineering Geologists, Special Publication, Published July 1973, p. 44.

Berger & Schug, 1991, Probabilistic Evaluation of Seismic Hazard in the San Diego-Tijuana Metropolitan Region, Environmental Perils, San Diego Region, San Diego Association of Geologists.

Blake, Thomas, 2002, EQFault and EQSearch Computer Programs for Deterministic Prediction and Estimation of Peak Horizontal Acceleration from Digitized California Faults and Historical Earthquake Catalogs.

Bryant, W.A. and E.W. Hart, 1973 (10<sup>th</sup> Revision 1997), Fault-Rupture Hazard Zones in California, Calif. Div. Of Mines and Geology, Special Publication 42.

California Division of Mines and Geology – Alquist-Priolo Special Studies Zones Map, November 1, 1991.

Crowell, J.C., 1962, Displacement along the San Andreas Fault, California; Geologic Society of America Special Paper 71, 61 p.

Demere, Thomas A., 2003, Geology of San Diego County, California, BRCC San Diego Natural History Museum.

Greene, H.G., 1979, Implication of Fault Patterns in the Inner California Continental Borderland between San Pedro and San Diego, in "Earthquakes and Other Perils, San Diego Region," P.L. Abbott and W.J. Elliott, editors.

Greensfelder, R.W., 1974, Maximum Credible Rock Acceleration from Earthquakes in California; California Division of Mines and Geology, Map Sheet 23.

Hart, E.W., D.P. Smith, and R.B. Saul, 1979, Summary Report: Fault Evaluation Program, 1978 Area (Peninsular Ranges-Salton Trough Region), Calif. Div. Of Mines and Geology, OFR 79-10 SF, 10.

Hart E.W. and W. A. Bryant, 1997, Fault-Rupture Hazard Zones in California, Calif. Geological Survey, Special Publication 42, Supplements 1 and 2 added 1999.

Hauksson, E. and L. Jones, 1988, The July 1988 Oceanside ( $M_L=5.3$ ) Earthquake Sequence in the Continental Borderland, Southern California Bulletin of the Seismological Society of America, v. 78, p. 1885-1906.

Hileman, J.A., C.R. Allen and J.M. Nordquist, 1973, Seismicity of the Southern California Region, January 1, 1932 to December 31, 1972; Seismological Laboratory, Cal-Tech, Pasadena, Calif.

Kennedy, M.P. and S.S. Tan, 2005, Geologic Map of San Diego, 30'x60' Quadrangle, California.

Kennedy, M. P., S. H. Clarke, H. G. Greene, R. C. Jachens, V. E. Langenheim, J. J. Moore and D. M. Burns, 1994, A digital (GIS) Geological/Geophysical/Seismological Data Base for the san Diego 30'x60 Quadrangle, California—A New Generation, Geological Society of America Abstracts with Programs. V. 26, p. 63.



Kennedy, M. P. and S. H. Clarke, 1997A, Analysis of Late Quaternary Faulting in San Diego Bay and Hazard to the Coronado Bridge, Calif. Div. Of Mines and Geology Open-file Report 97-10A.

Kennedy, M. P. and S. H. Clarke, 1997B, Age of Faulting in San Diego Bay in the Vicinity of the Coronado Bridge, an addendum to Analysis of Late Quaternary Faulting in San Diego Bay and Hazard to the Coronado Bridge, Calif. Div. Of Mines and Geology Open-file Report 97-10B.

Kennedy, M. P. and S. H. Clarke, 2001, Late Quaternary Faulting in San Diego Bay and Hazard to the Coronado Bridge, California Geology, July/August 2001.

Kennedy, M.P. and S.S. Tan, 1977, Geology of National City, Imperial Beach, and Otay Mesa Quadrangles, Southern San Diego Metropolitan Area, California, Map Sheet 29, California Division of Mines and Geology, 1977.

Kennedy, M.P., S.S. Tan, R.H. Chapman, and G.W. Chase, 1975; Character and Recency of Faulting, San Diego Metropolitan Area, California, Special Report 123, Calif. Div. Of Mines and Geology.

Kennedy, M.P. and E.E. Welday, 1980, Character and Recency of Faulting Offshore, metropolitan San Diego California, Calif. Div. Of Mines and Geology Map Sheet 40, 1:50,000.

Kern, J.P. and T.K. Rockwell, 1992, Chronology and Deformation of Quaternary Marine Shorelines, San Diego County, California in Heath, E. and L. Lewis (editors), The Regressive Pleistocene Shoreline, Coastal Southern California, pp. 1-8.

Kern, Philip, 1983, Earthquakes and Faults in San Diego, Pickle Press, San Diego, California.

McEuen, R.B. and C.J. Pinckney, 1972, Seismic Risk in San Diego; Transactions of the San Diego Society of Natural History, Vol. 17, No. 4, 19 July 1972.

Richter, C.G., 1958, Elementary Seismology, W.H. Freeman and Company, San Francisco, Calif.

Rockwell, T.K., D.E. Millman, R.S. McElwain, and D.L. Lamar, 1985, Study of Seismic Activity by Trenching Along the Glen Ivy North Fault, Elsinore Fault Zone, Southern California: Lamar-Merifield Technical Report 85-1, U.S.G.S. Contract 14-08-0001-21376, 19 p.

Simons, R.S., 1977, Seismicity of San Diego, 1934-1974, Seismological Society of America Bulletin, v. 67, p. 809-826.

Tan, S.S., 1995, Landslide Hazards in Southern Part of San Diego Metropolitan Area, San Diego County, Calif. Div. Of Mines and Geology Open-file Report 95-03.

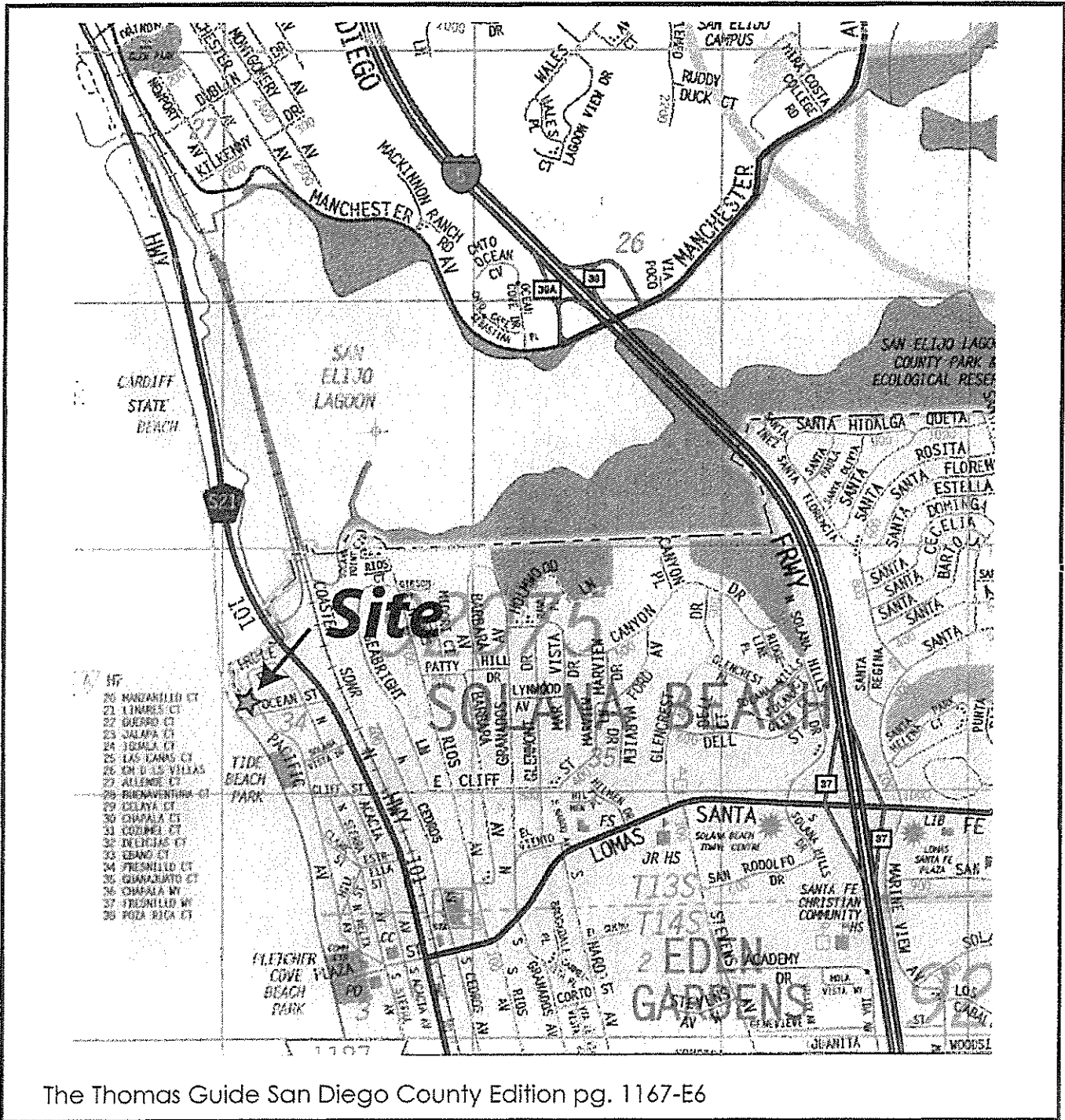
Topozada, T.R. and D.L. Parke, 1982, Areas Damaged by California Earthquakes, 1900-1949; Calif. Div. Of Mines and Geology, Open-file Report 82-17, Sacramento, Calif.

Treiman, J.A., 1993, The Rose Canyon Fault Zone, Southern California, Calif. Div. Of Mines and Geology Open-file Report 93-02, 45 pp, 3 plates.

U.S. Dept. of Agriculture, 1953, Aerial Photographs AXN-8M-79 and 80.



# VICINITY MAP



The Thomas Guide San Diego County Edition pg. 1167-E6

Harris Residence  
601 W. Circle Drive  
Solana Beach, CA.

Figure No. 1  
Job No. 11-10035



**Legend**

- ASSUMED PROPERTY BOUNDARY
- HP-6 APPROXIMATE LOCATION OF EXPLORATORY HANDPIT
- A A' GEOLOGIC CROSS SECTION
- Qt TERRACE DEPOSITS
- Tt TORREY SANDSTONE
- APPROXIMATE GEOLOGIC CONTACT
- SLOPE STABILITY SETBACK SF = 1.5



AS-SAN-LO AERIAL SURVEYS  
 4875 VERNON AVE., SAN DIEGO, CA 92131-1087 (619) 566-1034  
 PLAN NO. 11-10035-P  
 SHEET 1 OF 1  
 CONTOUR INTERVAL: 1'



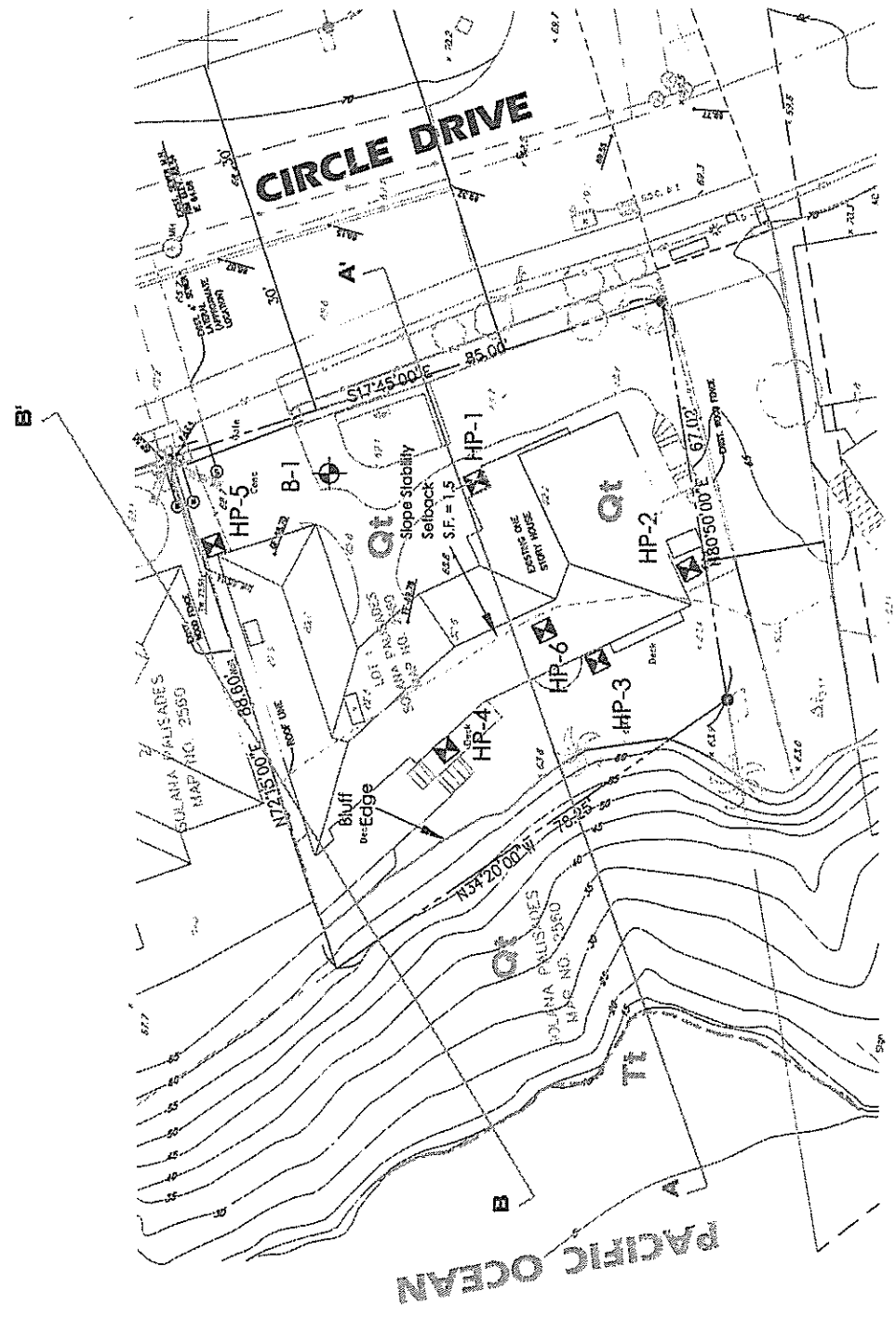
SCALE: 1" = 20'

**PLOT PLAN AND GEOLOGIC MAP**

Harris Residence  
 601 W. Circle Drive  
 Solana Beach, CA.  
 Figure No. II  
 Job No. 11-10035



August 2011



NOTE: This Plot Plan is not to be used for legal purposes. Dimensions and locations of utilities may be obtained from the Approved Building Plans or the "As-Built" Grading Plans.

REFERENCE: This Plot Plan was prepared from an existing Boundary and Topography Call plan by JP Engineering, Land Planning, Surveying and Erosion on-Site field reconnaissance performed by GEL.

EQUIPMENT <b>Truck-mounted Auger Drill Rig</b>	DIMENSION & TYPE OF EXCAVATION <b>6-inch diameter Boring</b>	DATE LOGGED <b>5-19-11</b>
SURFACE ELEVATION <b>± 69' Mean Sea Level</b>	GROUNDWATER/ SEEPAGE DEPTH <b>Not Encountered</b>	LOGGED BY <b>SO</b>

DEPTH (feet)	SYMBOL	SAMPLE	FIELD DESCRIPTION AND CLASSIFICATION		U.S.C.S.	IN-PLACE MOISTURE (%)	IN-PLACE DRY DENSITY (pcf)	OPTIMUM MOISTURE (%)	MAXIMUM DRY DENSITY (pcf)	DENSITY (% of M.D.D.)	EXPAN. + CONSOL. (%)	BLOW COUNTS/FT.	SAMPLE O.D. (INCHES)
			DESCRIPTION AND REMARKS (Grain size, Density, Moisture, Color)										
2			<b>SILTY SAND</b> , fine- to medium-grained, with occasional roots. Loose to medium dense. Moist. Dark brown.		SM								
4			<b>FILL (Qaf)</b> <b>SILTY SAND</b> , fine- to medium-grained, minor cohesion. Medium dense. Moist. Brown.		SM	7.1	106.0					12	3"
6			<b>TOPSOIL/ WEATHERED TERRACE DEPOSITS (Qt)</b>		SM							5	2"
8			<b>SILTY SAND</b> , fine- to medium-grained, with manganese flecks; minor to moderate cohesion. Medium dense. Moist. Red-brown.									19	3"
10			<b>TERRACE DEPOSITS (Qt)</b>									17	2"
12												20	3"
14			-- 19% passing -200 sieve.					8.1	128.0			20	2"
16			-- becomes tan and red-brown; minor cohesion.									42	3"
18												29	2"
20			-- becomes tan-brown; minor cohesion; medium-grained.									41	2"
22													
24													
26						3.2	103.7					81	3"
28													

EXPLORATION LOG 10035 HARRIS.GPJ GEO EXPL.GDT 7/25/11

	JOB NAME <b>Harris Residence</b>	SITE LOCATION <b>601 W. Circle Drive, Solana Beach, CA</b>	
	JOB NUMBER <b>11-10035</b>	REVIEWED BY <b>LDR/JAC</b>	LOG No. <b>B-1</b>
	FIGURE NUMBER <b>IIIa</b>		

EQUIPMENT <b>Truck-mounted Auger Drill Rig</b>	DIMENSION & TYPE OF EXCAVATION <b>6-inch diameter Boring</b>	DATE LOGGED <b>5-19-11</b>
SURFACE ELEVATION <b>± 69' Mean Sea Level</b>	GROUNDWATER/ SEEPAGE DEPTH <b>Not Encountered</b>	LOGGED BY <b>SO</b>

DEPTH (feet)	SYMBOL	SAMPLE	FIELD DESCRIPTION AND CLASSIFICATION		U.S.C.S.	IN-PLACE MOISTURE (%)	IN-PLACE DRY DENSITY (pcf)	OPTIMUM MOISTURE (%)	MAXIMUM DRY DENSITY (pcf)	DENSITY (% of M.D.D.)	EXPAN. + CONSOL. (%)	BLOW COUNTS/FT.	SAMPLE O.D. (INCHES)
			DESCRIPTION AND REMARKS (Grain size, Density, Moisture, Color)										
32			<b>SILTY SAND</b> , fine- to medium-grained, with manganese flecks; minor to moderate cohesion. Medium dense. Moist. Red-brown.		SM							41	2"
34			<b>TERRACE DEPOSITS (Qt)</b> -- 6% passing -200 sieve. -- manganese staining increases from 34' to 35'.					10.0	108.6				
36			<b>SAND</b> , fine- to medium-grained, with some silt; minor cohesion. Dense to very dense. Moist. Light tan-brown with orange (iron) staining.		SM-SP	1.7	103.7					89	3"
38			<b>TORREY SANDSTONE (Tt)</b>										
40												69	2"
42													
44													
46												67	2"
48													
50			- very dense; minor to moderate cohesion.			4.9	93.7					50/4"	3"
52												50/4"	2"
54			Bottom @ 50.66'										
56													
58													

EXPLORATION LOG 10035 HARRIS.GPJ GEO. EXPL.GDT 7/29/11

<ul style="list-style-type: none"> <li> PERCHED WATER TABLE</li> <li> LOOSE BAG SAMPLE</li> <li> IN-PLACE SAMPLE</li> <li> MODIFIED CALIFORNIA SAMPLE</li> <li> FIELD DENSITY TEST</li> <li> STANDARD PENETRATION TEST</li> </ul>	JOB NAME <b>Harris Residence</b>		LOG No. <b>B-1</b>
	SITE LOCATION <b>601 W. Circle Drive, Solana Beach, CA</b>		
	JOB NUMBER <b>11-10035</b>	REVIEWED BY <b>LDR/JAC</b>	
	FIGURE NUMBER <b>IIIb</b>		

EQUIPMENT <b>Hand Tools, Hand Auger</b>	DIMENSION & TYPE OF EXCAVATION <b>3' X 3' X 6' Handpit</b>	DATE LOGGED <b>5-19-11</b>
SURFACE ELEVATION <b>± 69' Mean Sea Level</b>	GROUNDWATER/ SEEPAGE DEPTH <b>Not Encountered</b>	LOGGED BY <b>JKH</b>

DEPTH (feet)	SYMBOL	FIELD DESCRIPTION AND CLASSIFICATION		U.S.C.S.	IN-PLACE MOISTURE (%)	IN-PLACE DRY DENSITY (pcf)	OPTIMUM MOISTURE (%)	MAXIMUM DRY DENSITY (pcf)	DENSITY (% of M.D.D.)	EXPAN. + CONSOL. (%)	BLOW COUNTS/FT.	SAMPLE O.D. (INCHES)
		DESCRIPTION AND REMARKS (Grain size, Density, Moisture, Color)										
1		<b>SILTY SAND</b> , fine- to medium-grained, with some roots and rock fragments. Loose to medium dense. Damp. Dark red-brown.		SM								
		<b>FILL (Qaf)</b> Footing: 12" deep, 12" wide. -- 3/4" PVC pipe. -- two 4" diameter red clay pipes.			9.8	105.3			85			
2							8.7	124.2				
3		Hand auger from 3.5'- 6'.										
4		<b>SILTY SAND</b> , fine- to medium-grained, poorly indurated. Loose to medium dense. Damp. Dark brown.		SM								
		<b>TOPSOIL/ WEATHERED TERRACE DEPOSITS (Qt)</b> -- probes tight @ 5.5'.										
5		<b>SAND</b> , fine- to medium-grained, with slight silt. Medium dense. Damp. Red-brown.		SM								
6		<b>TERRACE DEPOSITS (Qt)</b> Bottom @ 6'										

EXPLORATION LOG 10035 HARRIS, GP., GEO. EXPL. GDT. 7/25/11

- PERCHED WATER TABLE
- LOOSE BAG SAMPLE
- IN-PLACE SAMPLE
- MODIFIED CALIFORNIA SAMPLE
- FIELD DENSITY TEST
- STANDARD PENETRATION TEST

JOB NAME <b>Harris Residence</b>		LOG No.	
SITE LOCATION <b>601 W. Circle Drive, Solana Beach, CA</b>			
JOB NUMBER <b>11-10035</b>	REVIEWED BY <b>LDR/JAC</b>	 <b>HP-1</b>	
FIGURE NUMBER <b>IIIc</b>			



EQUIPMENT <b>Hand Tools</b>	DIMENSION & TYPE OF EXCAVATION <b>3' X 3' X 6' Handpit</b>	DATE LOGGED <b>5-19-11</b>
SURFACE ELEVATION <b>± 64' Mean Sea Level</b>	GROUNDWATER/ SEEPAGE DEPTH <b>Not Encountered</b>	LOGGED BY <b>JKH</b>

DEPTH (feet)	SYMBOL	FIELD DESCRIPTION AND CLASSIFICATION		U.S.C.S.	IN-PLACE MOISTURE (%)	IN-PLACE DRY DENSITY (pcf)	OPTIMUM MOISTURE (%)	MAXIMUM DRY DENSITY (pcf)	DENSITY (% of M.D.D.)	EXPAN. + CONSOL. (%)	BLOW COUNTS/FT.	SAMPLE O.D. (INCHES)
		DESCRIPTION AND REMARKS (Grain size, Density, Moisture, Color)										
1		<b>SILTY SAND</b> , fine- to medium-grained, with some roots and asphalt chunks. Loose to medium dense. Damp. Red-brown with black staining.		SM								
		<b>FILL (Qaf)</b> Footing: 12" deep, 12" wide.										
3		-- 4" diameter asphalt chunk.										
4		<b>SILTY SAND</b> , fine- to medium-grained, poorly indurated. Loose to medium dense. Damp. Dark brown.		SM								
		<b>TOPSOIL/ WEATHERED TERRACE DEPOSITS (Qt)</b>										
6		<b>SAND</b> , fine- to medium-grained, with slight silt. Medium dense. Damp. Red-brown.		SM								
		<b>TERRACE DEPOSITS (Qt)</b>										
		Bottom @ 6'										

EXPLORATION LOG 10035 HARRIS.GPJ GEO\_EXPL\_GDT 7/25/11

- PERCHED WATER TABLE
- LOOSE BAG SAMPLE
- IN-PLACE SAMPLE
- MODIFIED CALIFORNIA SAMPLE
- FIELD DENSITY TEST
- STANDARD PENETRATION TEST

JOB NAME <b>Harris Residence</b>		LOG No. <b>HP-2</b>
SITE LOCATION <b>601 W. Circle Drive, Solana Beach, CA</b>		
JOB NUMBER <b>11-10035</b>	REVIEWED BY <b>LDR/JAC</b>	
FIGURE NUMBER <b>III d</b>		

EQUIPMENT <b>Hand Tools</b>	DIMENSION & TYPE OF EXCAVATION <b>3' X 3' X 3.5' Handpit</b>	DATE LOGGED <b>5-19-11</b>
SURFACE ELEVATION <b>± 63' Mean Sea Level</b>	GROUNDWATER/ SEEPAGE DEPTH <b>Not Encountered</b>	LOGGED BY <b>JKH</b>

DEPTH (feet)	SYMBOL	SAMPLE	FIELD DESCRIPTION AND CLASSIFICATION		U.S.C.S.	IN-PLACE MOISTURE (%)	IN-PLACE DRY DENSITY (pcf)	OPTIMUM MOISTURE (%)	MAXIMUM DRY DENSITY (pcf)	DENSITY (% of M.D.D.)	EXPAN. + CONSOL. (%)	BLOW COUNTS/FT.	SAMPLE O.D. (INCHES)
			DESCRIPTION AND REMARKS (Grain size, Density, Moisture, Color)										
1			<b>SILTY SAND</b> , fine- to medium-grained, with roots and rock fragments. Loose. Dry to damp. Dark brown.  <b>FILL (Qaf)</b>		SM								
2			Footing: 18" deep, 10" wide. <b>SILTY SAND</b> , fine- to medium-grained, with roots; poorly indurated. Loose to medium dense. Damp. Dark brown.  <b>TOPSOIL/ WEATHERED TERRACE DEPOSITS (Qt)</b>		SM								
3			-- probes tight @ 3'. <b>SAND</b> , fine- to medium-grained, with slight silt. Medium dense. Damp. Red-brown.  <b>TERRACE DEPOSITS (Qt)</b>		SM								
4			Bottom @ 3.5'										

EXPLORATION LOG 10035 HARRIS.GPJ GEO. EXPL.GDT 7/25/11

<input checked="" type="checkbox"/> PERCHED WATER TABLE <input checked="" type="checkbox"/> LOOSE BAG SAMPLE <input type="checkbox"/> IN-PLACE SAMPLE <input checked="" type="checkbox"/> MODIFIED CALIFORNIA SAMPLE <input type="checkbox"/> FIELD DENSITY TEST <input checked="" type="checkbox"/> STANDARD PENETRATION TEST	JOB NAME <b>Harris Residence</b>	SITE LOCATION <b>601 W. Circle Drive, Solana Beach, CA</b>	
	JOB NUMBER <b>11-10035</b>	REVIEWED BY <b>LDR/JAC</b>	LOG No.
	FIGURE NUMBER <b>IIIe</b>	<b>Geotechnical Exploration, Inc.</b>	<b>HP-3</b>

EQUIPMENT <b>Hand Tools</b>	DIMENSION & TYPE OF EXCAVATION <b>3' X 3' X 3' Handpit</b>	DATE LOGGED <b>5-19-11</b>
SURFACE ELEVATION <b>± 64' Mean Sea Level</b>	GROUNDWATER/ SEEPAGE DEPTH <b>Not Encountered</b>	LOGGED BY <b>JKH</b>

DEPTH (feet)	SYMBOL	SAMPLE	FIELD DESCRIPTION AND CLASSIFICATION		U.S.C.S.	IN-PLACE MOISTURE (%)	IN-PLACE DRY DENSITY (pcf)	OPTIMUM MOISTURE (%)	MAXIMUM DRY DENSITY (pcf)	DENSITY (% of M.D.)	EXPAN. + (%)	CONSOL. - (%)	BLOW COUNTS/FT.	SAMPLE O.D. (INCHES)
			DESCRIPTION AND REMARKS (Grain size, Density, Moisture, Color)											
1			<b>SILTY SAND</b> , fine- to medium-grained, with some roots and plastic debris. Loose. Damp. Dark brown.  <b>FILL (Qaf)</b>		SM									
			Footing: 18" deep, 12" wide.											
2			<b>SILTY SAND</b> , fine- to medium-grained, with some roots. Loose to medium dense. Damp. Dark brown.  <b>TOPSOIL/ WEATHERED TERRACE DEPOSITS (Qt)</b>		SM	6.3	108.7							
3			<b>SAND</b> , fine- to medium-grained, with slight silt. Medium dense. Damp. Red-brown.  <b>TERRACE DEPOSITS (Qt)</b> -- probes tight @ 3'. Bottom @ 3'		SM									

EXPLORATION LOG 10035 HARRIS.GPJ GEO\_EXPL.GDT 7/25/11

PERCHED WATER TABLE LOOSE BAG SAMPLE IN-PLACE SAMPLE MODIFIED CALIFORNIA SAMPLE FIELD DENSITY TEST STANDARD PENETRATION TEST	JOB NAME <b>Harris Residence</b>	SITE LOCATION <b>601 W. Circle Drive, Solana Beach, CA</b>	
	JOB NUMBER <b>11-10035</b>	REVIEWED BY <b>LDR/JAC</b>	LOG No. <b>HP-4</b>
	FIGURE NUMBER <b>IIIf</b>		

EQUIPMENT <b>Hand Tools</b>	DIMENSION & TYPE OF EXCAVATION <b>3' X 3' X 3.5' Handpit</b>	DATE LOGGED <b>5-19-11</b>
SURFACE ELEVATION <b>± 69' Mean Sea Level</b>	GROUNDWATER/ SEEPAGE DEPTH <b>Not Encountered</b>	LOGGED BY <b>JKH</b>

DEPTH (feet)	SYMBOL	FIELD DESCRIPTION AND CLASSIFICATION		U.S.C.S.	IN-PLACE MOISTURE (%)	IN-PLACE DRY DENSITY (pcf)	OPTIMUM MOISTURE (%)	MAXIMUM DRY DENSITY (pcf)	DENSITY (% of M.I.D.)	EXPAN. + CONSOL. (%)	BLOW COUNTS/FT.	SAMPLE O.D. (INCHES)
		DESCRIPTION AND REMARKS (Grain size, Density, Moisture, Color)										
1		<b>SILTY SAND</b> , fine- to medium-grained, with some roots and rock fragments. Loose. Damp. Dark brown.  <b>FILL (Qaf)</b>		SM								
2		<b>SILTY SAND</b> , fine- to medium-grained, with some roots. Loose to medium dense. Damp. Dark brown.  <b>TOPSOIL/ WEATHERED TERRACE DEPOSITS (Qt)</b> Footing: 21" deep.		SM								
3		<b>SAND</b> , fine- to medium-grained, with slight silt. Medium dense. Damp. Red-brown.  <b>TERRACE DEPOSITS (Qt)</b>		SM								
4		Bottom @ 3.5'										

EXPLORATION LOG 10035 HARRIS.GPJ GEO\_EXPL.GDT 7/25/11

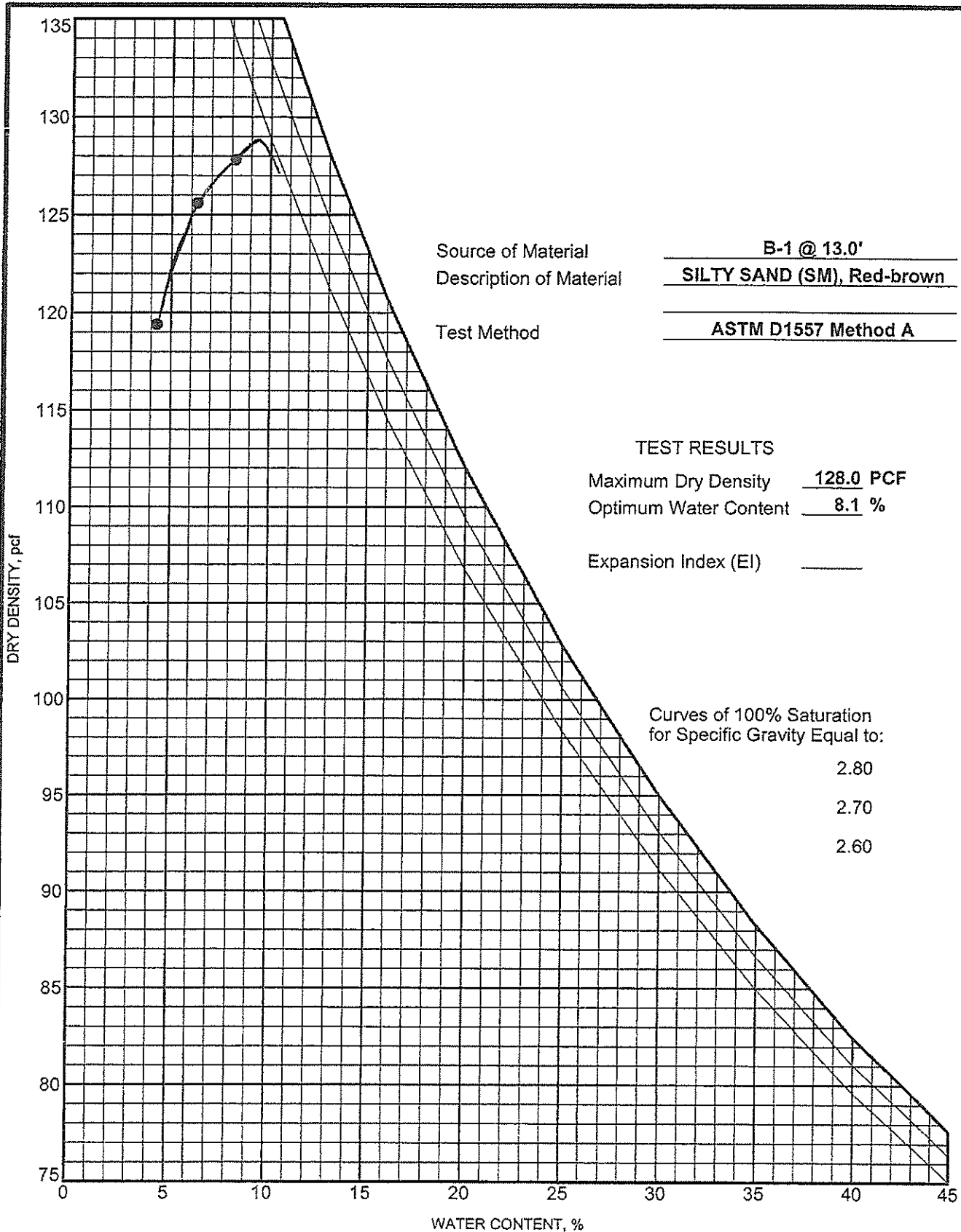
PERCHED WATER TABLE LOOSE BAG SAMPLE IN-PLACE SAMPLE MODIFIED CALIFORNIA SAMPLE FIELD DENSITY TEST STANDARD PENETRATION TEST	JOB NAME <b>Harris Residence</b>
	SITE LOCATION <b>601 W. Circle Drive, Solana Beach, CA</b>
	JOB NUMBER <b>11-10035</b>
	FIGURE NUMBER <b>IIIg</b>
REVIEWED BY <b>LDR/JAC</b>	LOG No. <b>HP-5</b>

EQUIPMENT <b>Hand Tools</b>	DIMENSION & TYPE OF EXCAVATION <b>2' X 2' X 2' Handpit</b>	DATE LOGGED <b>5-19-11</b>
SURFACE ELEVATION <b>± 63' Mean Sea Level</b>	GROUNDWATER/ SEEPAGE DEPTH <b>Not Encountered</b>	LOGGED BY <b>JKH</b>

DEPTH (feet)	SYMBOL	FIELD DESCRIPTION AND CLASSIFICATION		U.S.C.S.	IN-PLACE MOISTURE (%)	IN-PLACE DRY DENSITY (pcf)	OPTIMUM MOISTURE (%)	MAXIMUM DRY DENSITY (pcf)	DENSITY (% of M.D.D.)	EXPAN. + CONSOL. (%)	BLOW COUNTS/FT.	SAMPLE O.D. (INCHES)
		DESCRIPTION AND REMARKS (Grain size, Density, Moisture, Color)										
1		<b>SILTY SAND</b> , fine- to medium-grained, with some rock fragments. Loose. Dry. Brown.  <b>FILL (Qaf)</b>		SM								
		Footing: 12" square pad footing, 12" deep.										
2		<b>SILTY SAND</b> , fine- to medium-grained. Medium dense. Damp. Red-brown.  <b>TOPSOIL/ WEATHERED TERRACE DEPOSITS (Qt)</b>		SM								
3		Bottom @ 2'										

EXPLORATION LOG 10035 HARRIS.GPJ GEO\_EXPL.GDT 7/25/11

PERCHED WATER TABLE LOOSE BAG SAMPLE IN-PLACE SAMPLE MODIFIED CALIFORNIA SAMPLE FIELD DENSITY TEST STANDARD PENETRATION TEST	JOB NAME <b>Harris Residence</b>	SITE LOCATION <b>601 W. Circle Drive, Solana Beach, CA</b>	
	JOB NUMBER <b>11-10035</b>	REVIEWED BY <b>LDR/JAC</b>	LOG No.
	FIGURE NUMBER <b>IIIh</b>		
		<b>HP-6</b>	



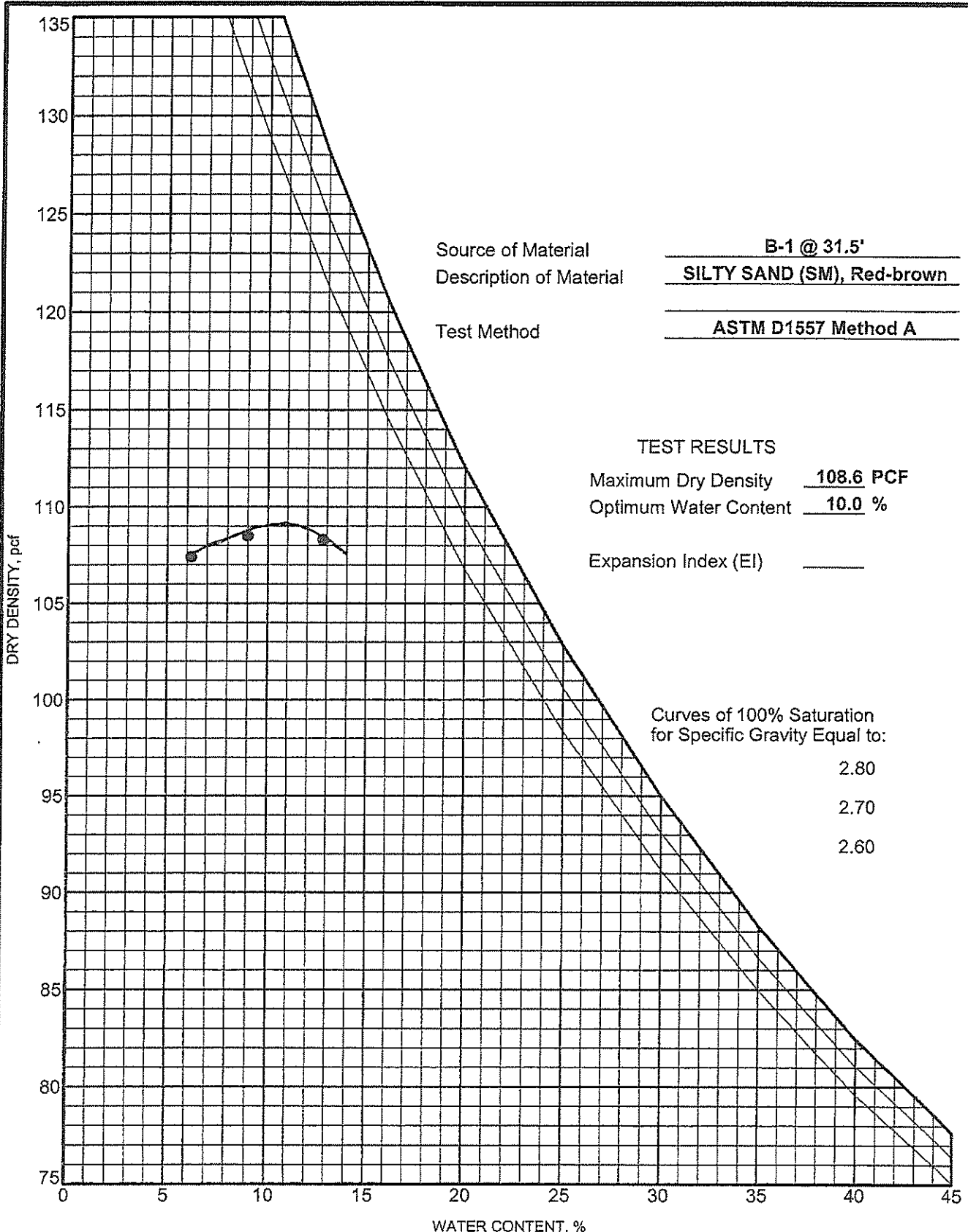
Source of Material B-1 @ 13.0'  
 Description of Material SILTY SAND (SM), Red-brown  
 Test Method ASTM D1557 Method A

Curves of 100% Saturation  
 for Specific Gravity Equal to:  
 2.80  
 2.70  
 2.60

COMPACTION + EI DARK GRID, 10035 HARRIS.GPJ, GEL FEB06.GDT, 7/25/11



**MOISTURE-DENSITY RELATIONSHIP**  
 Figure Number: IVa  
 Job Name: Harris Residence  
 Site Location: 601 W. Circle Drive, Solana Beach, CA  
 Job Number: 11-10035



Source of Material B-1 @ 31.5'  
 Description of Material SILTY SAND (SM), Red-brown  
 Test Method ASTM D1557 Method A

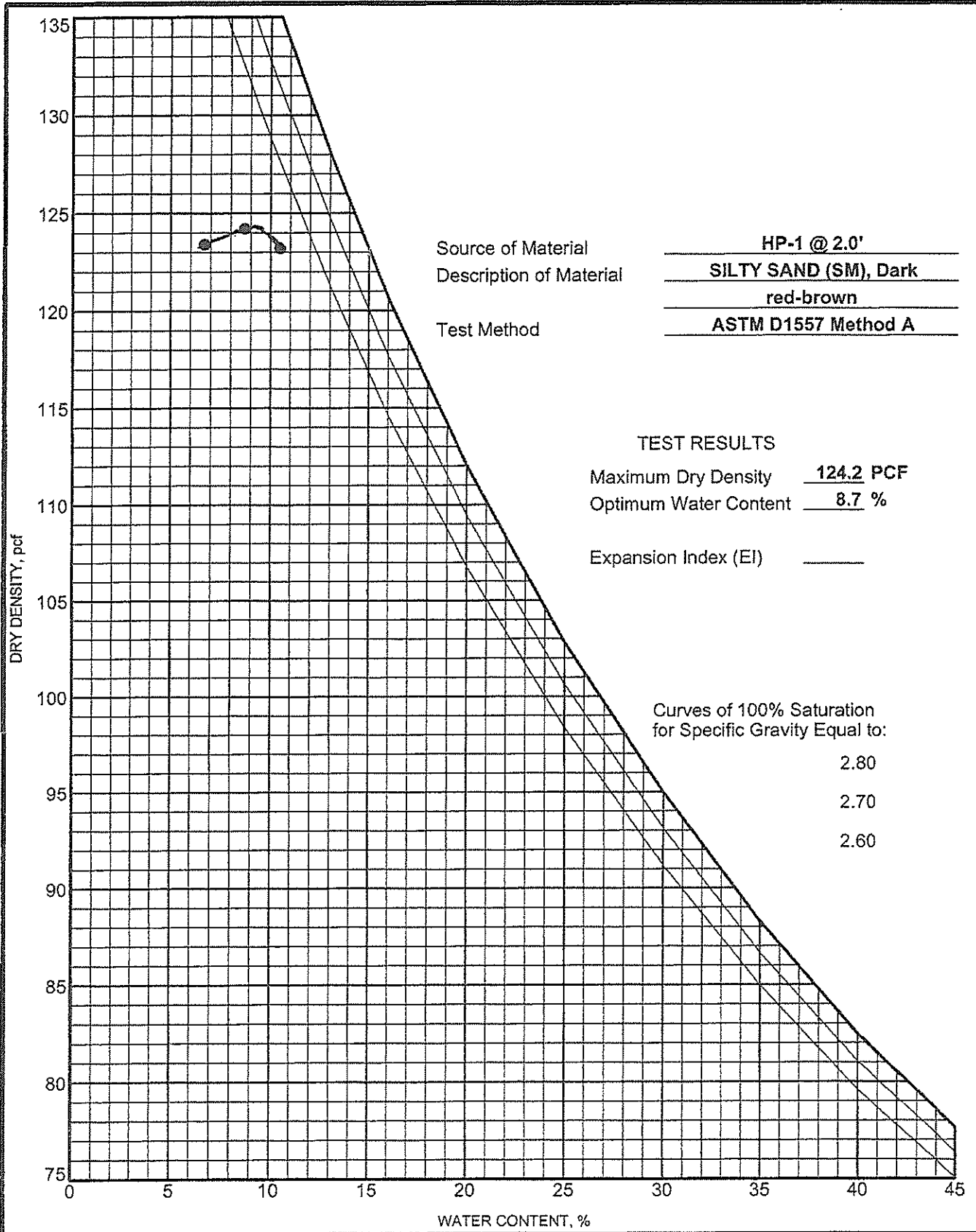
Curves of 100% Saturation  
 for Specific Gravity Equal to:  
 2.80  
 2.70  
 2.60

COMPACTION + EI DARK GRID 10035 HARRIS.GPJ GEI FEB06.GDT 7/25/11



**MOISTURE-DENSITY RELATIONSHIP**

Figure Number: IVb  
 Job Name: Harris Residence  
 Site Location: 601 W. Circle Drive, Solana Beach, CA  
 Job Number: 11-10035



COMPACTION - EL DARK GRID, 10035 HARRIS, GPJ, GEL FEB96, GDT, 7/25/11

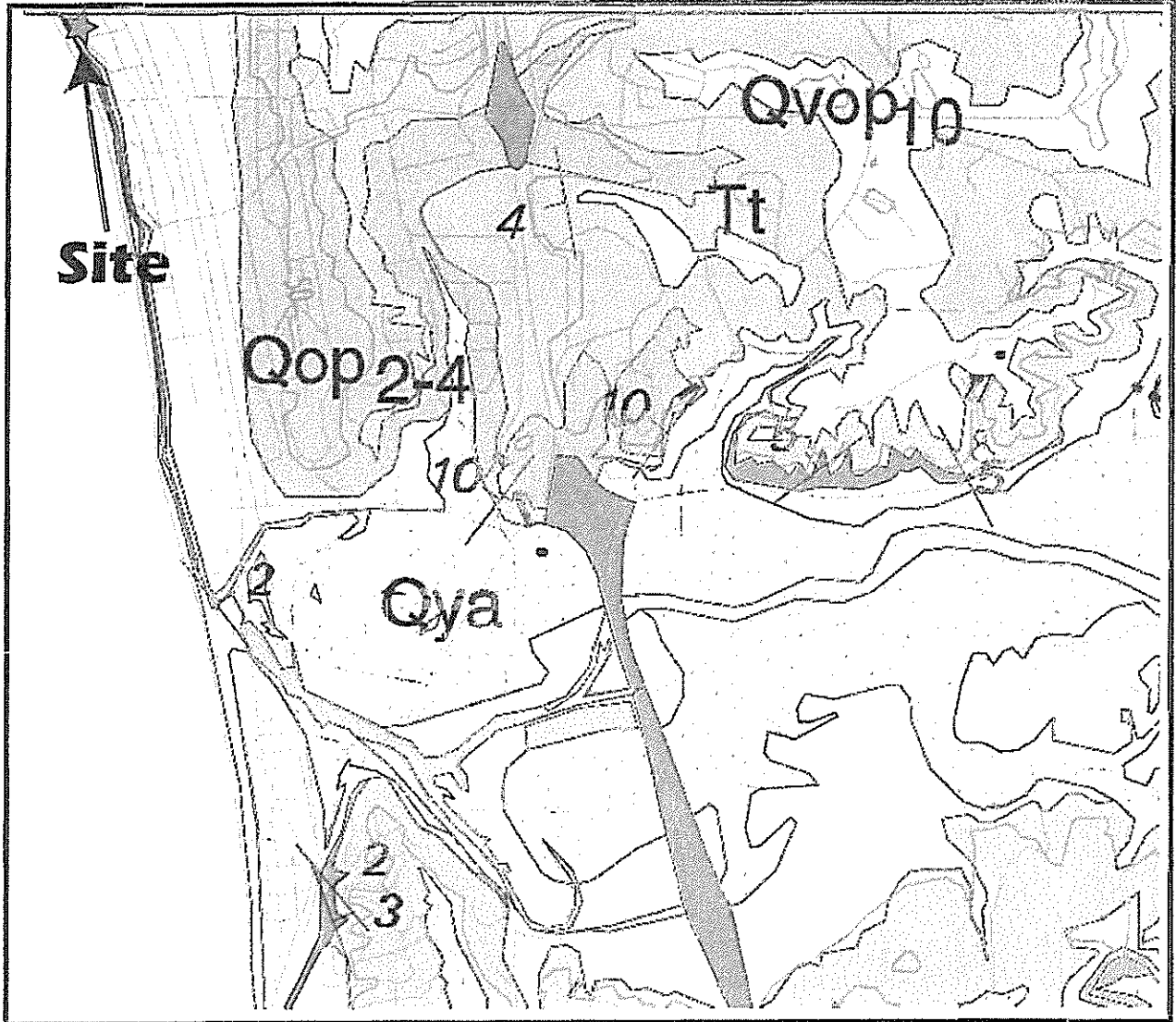


**MOISTURE-DENSITY RELATIONSHIP**  
 Figure Number: IVc  
 Job Name: Harris Residence  
 Site Location: 601 W. Circle Drive, Solana Beach, CA  
 Job Number: 11-10035



# GEOLOGIC MAP OF SAN DIEGO 2005

compiled by Michael P. Kennedy  
and Siang S Tan



Harris Residence  
601 W Circle Drive  
Solana Beach, CA.

Figure No. Va  
Job No. 11-10035



Correlation of Map Units and Description of Map Units  
for the  
**Geologic Map of the  
San Diego 30' X 60' Quadrangle, California**

Compiled by  
Michael P. Kennedy and Siang S. Tan

2005

Digital Preparation by  
Kelly R. Bovard<sup>1</sup>, Anne G. Garcia<sup>1</sup> and Diane Burns<sup>1</sup>

<sup>1</sup> U.S. Geological Survey, Department of Earth Sciences, University of California, Riverside

Group 7

**Old paralic deposits, Unit 7 (late to middle Pleistocene)**—Mostly poorly sorted, moderately permeable, reddish-brown, interfingered strandline, beach, estuarine and colluvial deposits composed of siltstone, sandstone and conglomerate. These deposits rest on the 9-11 m Bird Rock terrace (Fig. 3)

**ONSHORE MAP SYMBOLS**

- Contact—Contact between geologic units, dashed where concealed.
  - Contact—Contact between paralic deposits and their associated marine depositional platforms. This contact is approximate and generally based by 1-5 m of transect and/or summite sections.
  - Fault—Solid where accurately located; dashed where approximately located; dotted where concealed. U = upthrown block, D = downthrown block. Arrow and number indicate direction and angle of dip of fault plane.
  - Antiformal—Solid where accurately located; dashed where approximately located; dotted where concealed. Arrow indicates direction of axial plunge.
  - Synclinal—Solid where accurately located; dashed where concealed. Arrow indicates direction of axial plunge.
  - Landslide—Arrows indicate principal direction of movement.
  - Fault Zone—Area of extensively fractured rock within a zone defined by multiple faults.
- Strike and dip of beds
- Inclined
- Strike and dip of linear joints
- Inclined
  - Vertical
- Strike and dip of metamorphic foliation
- Inclined

**OFFSHORE MAP SYMBOLS**

- Contact—All contacts are extrapolated from a combination of seismic reflection data, samples, and bathymetry; and are approximate in location.
  - Fault—Solid where well defined; dashed where inferred. Where fault offsets sea floor, age symbol is shown on bar on downthrown side. Where age was determined, age symbol is shown inside fault and relative offset of known is shown by 'D' and 'U' on downthrown and upthrown sides. Ages of faults are indicated as follows:
    - H rest strata of Holocene age
    - C late strata of Quaternary age
    - M late strata of Miocene age or older
    - T late strata of late Tertiary and Quaternary age
  - Fault Zone—Area of extensively fractured rock within a zone defined by multiple faults.
- Folds
- Antiformal—Solid where well defined; dashed where inferred.
  - Synclinal—Solid where well defined; dashed where inferred.
- Landslides
- Creep—Location where inferred.
  - Creep (noted on single survey line)—Arrow indicates apparent direction of sediment movement.
  - Slump—Dashed where inferred, partial where uncertain. Arrows indicate direction of movement.
- Etched sand bars
- Etched sand bars—Solid where well defined; dashed where inferred. Generally associated with active channels.
- Channels and levees
- Active Channel—Dashed-dot line marks left, arrow indicates direction of pole-to-mouth transport.
  - Levee—Dashed where inferred.

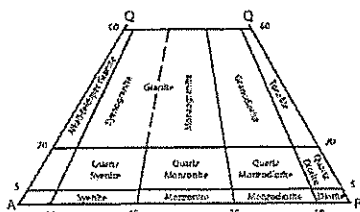


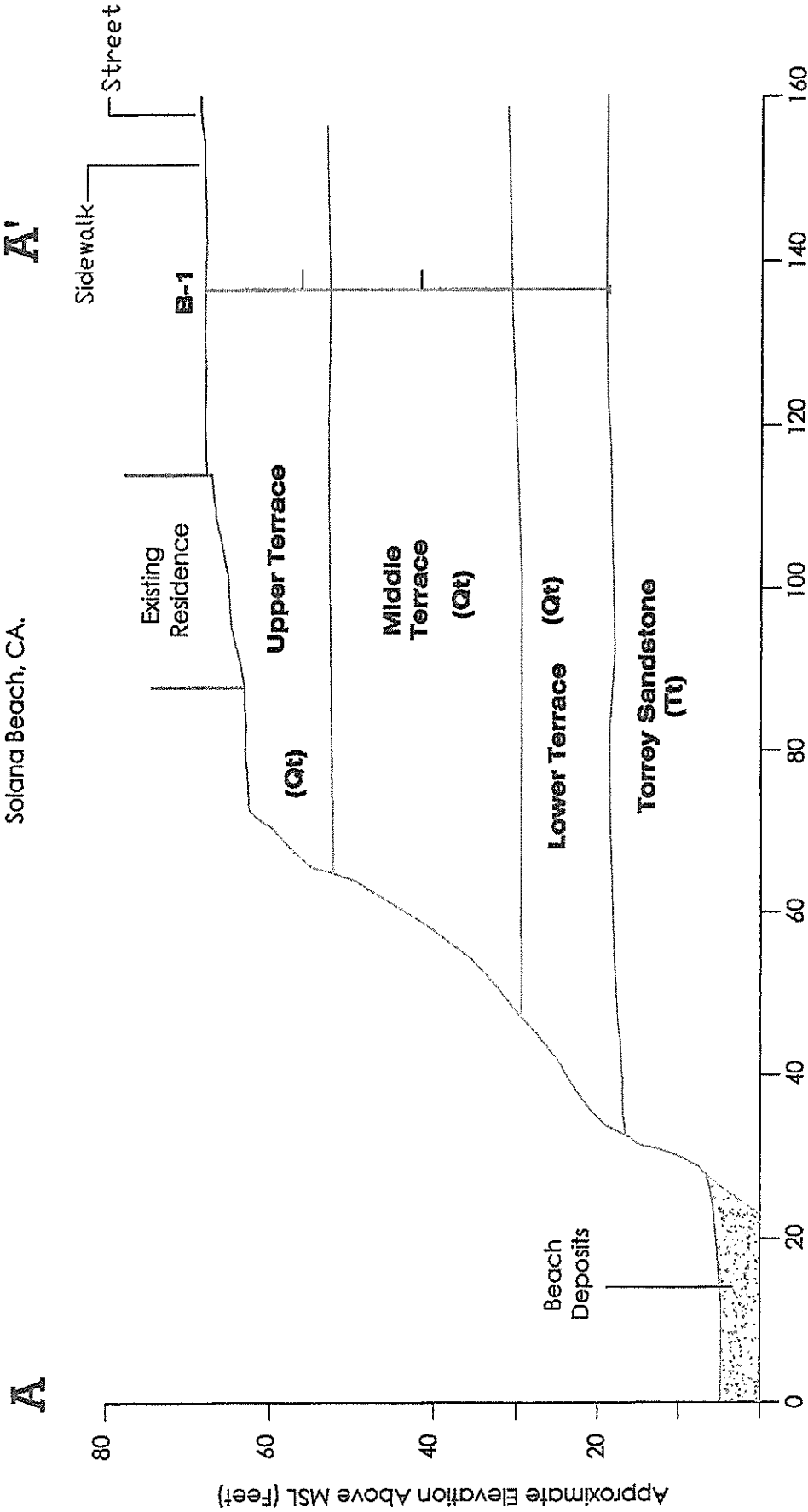
Figure 1. Classification of plutonic rock types (from IUGA, 1971, and Streckeisen, 1973). A, alkali feldspar; P, plagioclase-feldspar; Q, quartz.

Copyright © 2005 by the California Department of Conservation. All rights reserved. No part of this publication may be reproduced without written consent of the California Geological Survey. The Department of Conservation makes no warranties as to the suitability of this product for any particular purpose.

Figure No. Vb  
Job No. 11-10035  
 Geotechnical  
Exploration, Inc.

# GEOLOGIC CROSS SECTION A-A'

Harris Residence  
601 W. Circle Drive  
Solana Beach, CA.



Relative Horizontal Distance (feet)  
Scale: 1" = 20'  
(Horizontal and Vertical)

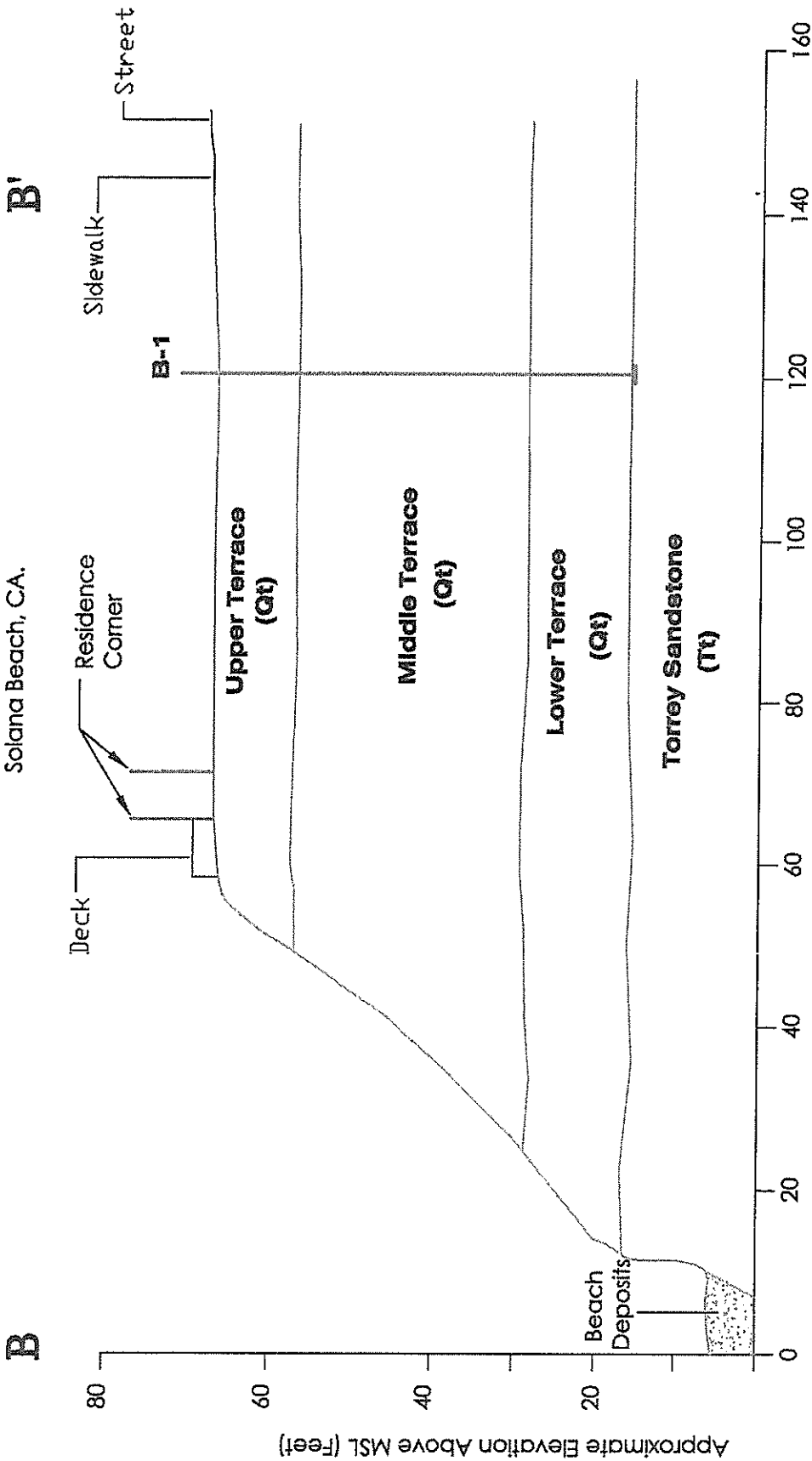
Figure No. Via  
Job No. 11-10035



NOTE: This Cross Section is not to be used for legal purposes. Locations and dimensions are approximate. Actual property dimensions and locations of utilities may be obtained from the Approved Building Plans or the "As-Built" Grading Plans.

# GEOLOGIC CROSS SECTION B-B'

Harris Residence  
601 W. Circle Drive  
Solana Beach, CA.



Relative Horizontal Distance (feet)  
Scale: 1" = 20'  
(Horizontal and Vertical)

NOTE: This Cross Section is not to be used for legal purposes. Locations and dimensions are approximate. Actual property dimensions and locations of utilities may be obtained from the Approved Building Plans or the "As-Built" Grading Plans.

Figure No. V1b  
Job No. 11-10035



July 2011

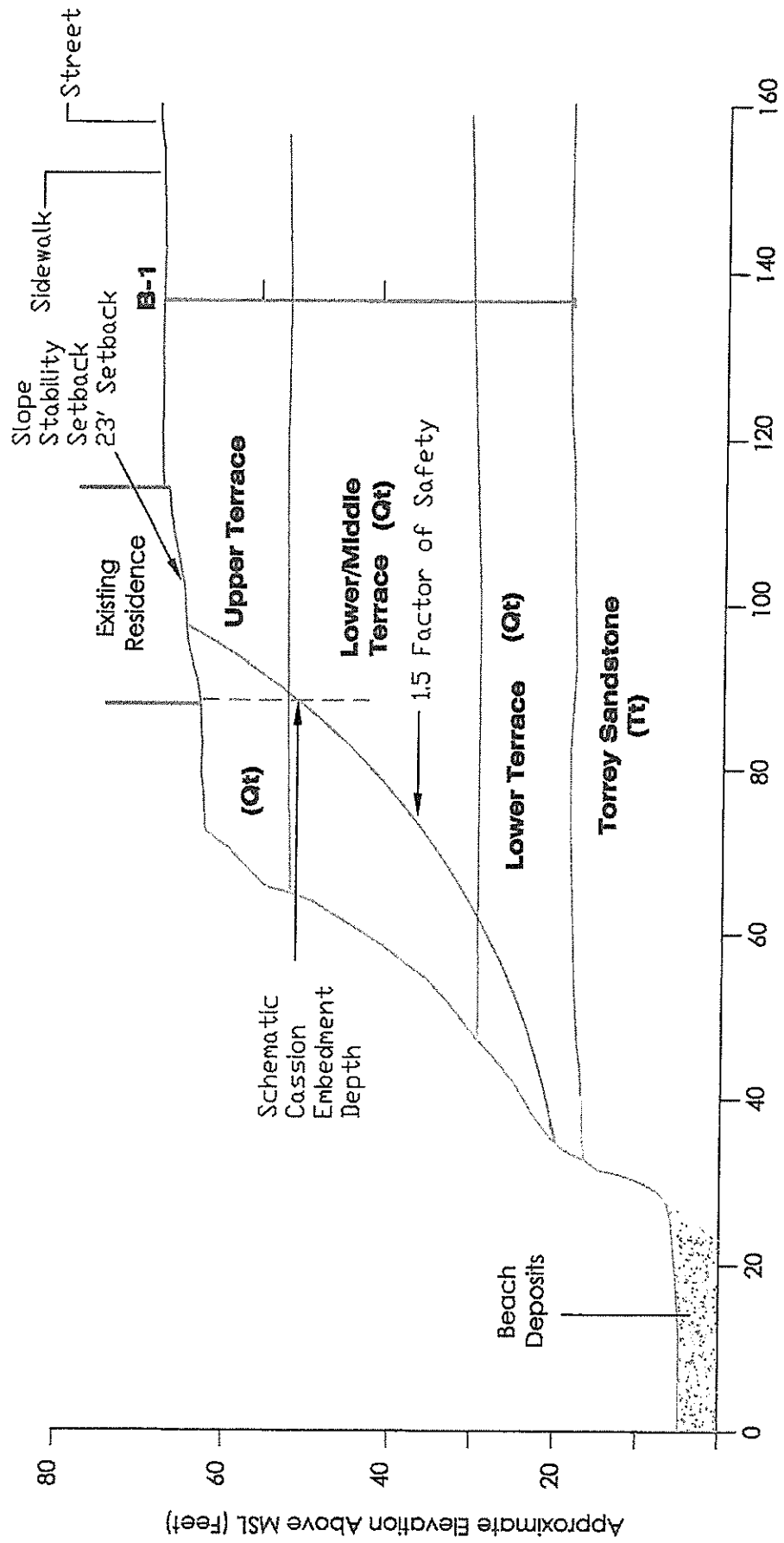
11-10035-BB

# CAISSON EMBEDMENT SCHEMATIC

Harris Residence  
601 W. Circle Drive  
Solana Beach, CA.

**A**

**A'**



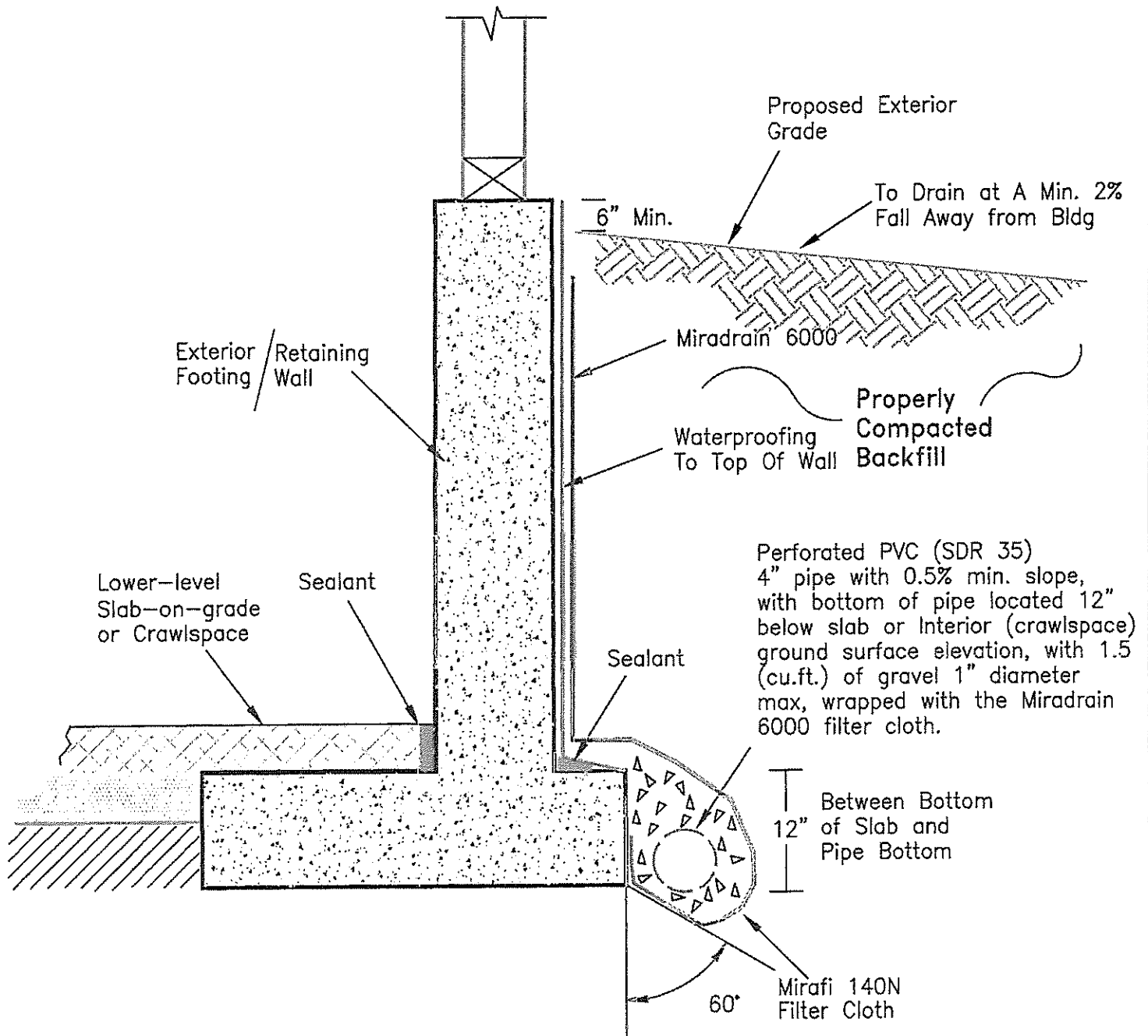
Relative Horizontal Distance (feet)  
Scale: 1" = 20'  
(Horizontal and Vertical)

NOTE: This Cross Section is not to be used for legal purposes. Locations and dimensions are approximate. Actual property dimensions and locations of utilities may be obtained from the Approved Building Plans or the "As-Built" Grading Plans.

Figure No. VII  
Job No. 11-10035



# RECOMMENDED SUBGRADE RETAINING WALL DRAINAGE SCHEMATIC



**NOT TO SCALE**

NOTE: As an option to Miradrain 6000, Gravel or Crushed rock 3/4" maximum diameter may be used with a minimum 12" thickness along the interior face of the wall and 2.0 cu.ft./ft. of pipe gravel envelope.

Figure No. VIII  
Job No. 11-10035



## APPENDIX A UNIFIED SOIL CLASSIFICATION CHART SOIL DESCRIPTION

### Coarse-grained (More than half of material is larger than a No. 200 sieve)

GRAVELS, CLEAN GRAVELS (More than half of coarse fraction is larger than No. 4 sieve size, but smaller than 3")	GW	Well-graded gravels, gravel and sand mixtures, little or no fines.
	GP	Poorly graded gravels, gravel and sand mixtures, little or no fines.
GRAVELS WITH FINES (Appreciable amount)	GC	Clay gravels, poorly graded gravel-sand-silt mixtures
SANDS, CLEAN SANDS (More than half of coarse fraction is smaller than a No. 4 sieve)	SW	Well-graded sand, gravelly sands, little or no fines
	SP	Poorly graded sands, gravelly sands, little or no fines.
SANDS WITH FINES (Appreciable amount)	SM	Silty sands, poorly graded sand and silty mixtures.
	SC	Clayey sands, poorly graded sand and clay mixtures.

### Fine-grained (More than half of material is smaller than a No. 200 sieve)

#### SILTS AND CLAYS

<u>Liquid Limit Less than 50</u>	ML	Inorganic silts and very fine sands, rock flour, sandy silt and clayey-silt sand mixtures with a slight plasticity
	CL	Inorganic clays of low to medium plasticity, gravelly clays, silty clays, clean clays.
	OL	Organic silts and organic silty clays of low plasticity.
<u>Liquid Limit Greater than 50</u>	MH	Inorganic silts, micaceous or diatomaceous fine sandy or silty soils, elastic silts.
	CH	Inorganic clays of high plasticity, fat clays.
	OH	Organic clays of medium to high plasticity.
HIGHLY ORGANIC SOILS	PT	Peat and other highly organic soils

(rev. 6/05)



**APPENDIX B**

**EQ FAULT TABLES**





TEST.OUT

```
*****  
*  
*   E Q F A U L T   *  
*  
*   Version 3.00   *  
*  
*****
```

DETERMINISTIC ESTIMATION OF  
PEAK ACCELERATION FROM DIGITIZED FAULTS

JOB NUMBER: 11-10035

DATE: 06-29-2011

JOB NAME: Harris Test Run

CALCULATION NAME: Test Run Analysis

FAULT-DATA-FILE NAME: CDMGFLTE.DAT

SITE COORDINATES:

SITE LATITUDE: 32.9992  
SITE LONGITUDE: 117.2773

SEARCH RADIUS: 100 mi

ATTENUATION RELATION: 11) Bozorgnia Campbell Niazi (1999) Hor.-Pleist. Soil-Cor.  
UNCERTAINTY (M=Median, S=Sigma): M                      Number of sigmas: 0.0  
DISTANCE MEASURE: cdist  
SCOND: 1  
Basement Depth: 5.00 km      Campbell SSR: 0      Campbell SHR: 0  
COMPUTE RHGA HORIZ. ACCEL. (FACTOR: 0.65      DISTANCE: 20 miles)

FAULT-DATA FILE USED: CDMGFLTE.DAT

MINIMUM DEPTH VALUE (km): 3.0

## EQFAULT SUMMARY

## DETERMINISTIC SITE PARAMETERS

Page 1

ABBREVIATED FAULT NAME	APPROXIMATE DISTANCE mi (km)	ESTIMATED MAX. EARTHQUAKE EVENT		
		MAXIMUM EARTHQUAKE MAG. (Mw)	RHGA SITE ACCEL. g	EST. SITE INTENSITY MOD. MERC.
ROSE CANYON	2.9( 4.6)	6.9	0.294	IX
NEWPORT-INGLEWOOD (Offshore)	14.1( 22.7)	6.9	0.160	VIII
CORONADO BANK	16.5( 26.5)	7.4	0.190	VIII
ELSINORE-JULIAN	30.1( 48.5)	7.1	0.086	VII
ELSINORE-TEMECULA	30.3( 48.8)	6.8	0.069	VI
EARTHQUAKE VALLEY	42.3( 68.1)	6.5	0.040	V
PALOS VERDES	43.1( 69.3)	7.1	0.059	VI
ELSINORE-GLEN IVY	44.7( 72.0)	6.8	0.046	VI
SAN JACINTO-ANZA	52.8( 85.0)	7.2	0.051	VI
ELSINORE-COYOTE MOUNTAIN	53.1( 85.5)	6.8	0.039	V
SAN JACINTO-COYOTE CREEK	54.7( 88.0)	6.8	0.037	V
SAN JACINTO-SAN JACINTO VALLEY	55.3( 89.0)	6.9	0.040	V
NEWPORT-INGLEWOOD (L.A.Basin)	56.3( 90.6)	6.9	0.039	V
CHINO-CENTRAL AVE. (Elsinore)	59.1( 95.1)	6.7	0.045	VI
WHITTIER	62.6( 100.8)	6.8	0.032	V
SAN JACINTO - BORREGO	64.3( 103.5)	6.6	0.028	V
COMPTON THRUST	65.9( 106.0)	6.8	0.044	VI
ELYSIAN PARK THRUST	69.6( 112.0)	6.7	0.039	V
SAN JACINTO-SAN BERNARDINO	70.3( 113.2)	6.7	0.027	V
SAN ANDREAS - San Bernardino	73.4( 118.1)	7.3	0.039	V
SAN ANDREAS - Southern	73.4( 118.1)	7.4	0.042	VI
SUPERSTITION MTN. (San Jacinto)	78.5( 126.4)	6.6	0.022	IV
SAN ANDREAS - Coachella	79.1( 127.3)	7.1	0.031	V
PINTO MOUNTAIN	79.9( 128.6)	7.0	0.029	V
SAN JOSE	80.0( 128.7)	6.5	0.029	V
ELMORE RANCH	82.5( 132.8)	6.6	0.021	IV
LAGUNA SALADA	83.1( 133.7)	7.0	0.028	V
SUPERSTITION HILLS (San Jacinto)	83.4( 134.3)	6.6	0.021	IV
SIERRA MADRE	83.6( 134.6)	7.0	0.039	V
BURNT MTN.	83.7( 134.7)	6.4	0.018	IV
CUCAMONGA	83.9( 135.1)	7.0	0.039	V
NORTH FRONTAL FAULT ZONE (west)	86.1( 138.5)	7.0	0.038	V
EUREKA PEAK	86.4( 139.0)	6.4	0.018	IV
CLEGHORN	88.1( 141.8)	6.5	0.018	IV
NORTH FRONTAL FAULT ZONE (East)	89.2( 143.5)	6.7	0.029	V
RAYMOND	91.6( 147.4)	6.5	0.025	V
SAN ANDREAS - 1857 Rupture	91.8( 147.7)	7.8	0.045	VI
SAN ANDREAS - Mojave	91.8( 147.7)	7.1	0.027	V
CLAMHELL-SAWPIT	93.4( 150.3)	6.5	0.024	V
VERDUGO	94.0( 151.3)	6.7	0.028	V

-----  
 DETERMINISTIC SITE PARAMETERS  
 -----

ABBREVIATED FAULT NAME	APPROXIMATE DISTANCE mi (km)	ESTIMATED MAX. EARTHQUAKE EVENT		
		MAXIMUM EARTHQUAKE MAG. (Mw)	RHGA SITE ACCEL. g	EST. SITE INTENSITY MOD. MERC.
BRAWLEY SEISMIC ZONE	94.1( 151.5)	6.4	0.016	IV
LANDERS	94.6( 152.3)	7.3	0.030	V
HOLLYWOOD	95.7( 154.0)	6.4	0.022	IV
HELENDALE - S. LOCKHARDT	97.7( 157.2)	7.1	0.025	V
IMPERIAL	99.3( 159.8)	7.0	0.023	IV
SANTA MONICA	100.0( 160.9)	6.6	0.024	V

\*\*\*\*\*

-END OF SEARCH- 46 FAULTS FOUND WITHIN THE SPECIFIED SEARCH RADIUS.

THE ROSE CANYON FAULT IS CLOSEST TO THE SITE.  
 IT IS ABOUT 2.9 MILES (4.6 km) AWAY.

LARGEST MAXIMUM-EARTHQUAKE SITE ACCELERATION: 0.2938 g

TEST.OUT

```
*****  
*                               *  
*   E Q F A U L T             *  
*   Version 3.00              *  
*                               *  
*****
```

DETERMINISTIC ESTIMATION OF  
PEAK ACCELERATION FROM DIGITIZED FAULTS

JOB NUMBER: 11-10035

DATE: 06-29-2011

JOB NAME: Harris Test Run

CALCULATION NAME: Test Run Analysis

FAULT-DATA-FILE NAME: CDMGFLTE.DAT

SITE COORDINATES:

SITE LATITUDE: 32.9992  
SITE LONGITUDE: 117.2773

SEARCH RADIUS: 100 mi

ATTENUATION RELATION: 11) Bozorgnia Campbell Niazi (1999) Hor.-Pleist. Soil-Cor.  
UNCERTAINTY (M=Median, S=Sigma): M Number of Sigmas: 0.0  
DISTANCE MEASURE: cdist  
SCOND: 1  
Basement Depth: 5.00 km Campbell SSR: 0 Campbell SHR: 0  
COMPUTE PEAK HORIZONTAL ACCELERATION

FAULT-DATA FILE USED: CDMGFLTE.DAT

MINIMUM DEPTH VALUE (km): 3.0

## EQFAULT SUMMARY

## DETERMINISTIC SITE PARAMETERS

Page 1

ABBREVIATED FAULT NAME	APPROXIMATE DISTANCE mi (km)	ESTIMATED MAX. EARTHQUAKE EVENT		
		MAXIMUM EARTHQUAKE MAG. (Mw)	PEAK SITE ACCEL. g	EST. SITE INTENSITY MOD.MERC.
ROSE CANYON	2.9( 4.6)	6.9	0.452	X
NEWPORT-INGLEWOOD (Offshore)	14.1( 22.7)	6.9	0.160	VIII
CORONADO BANK	16.5( 26.5)	7.4	0.190	VIII
ELSINORE-JULIAN	30.1( 48.5)	7.1	0.086	VII
ELSINORE-TEMECULA	30.3( 48.8)	6.8	0.069	VI
EARTHQUAKE VALLEY	42.3( 68.1)	6.5	0.040	V
PALOS VERDES	43.1( 69.3)	7.1	0.059	VI
ELSINORE-GLEN IVY	44.7( 72.0)	6.8	0.046	VI
SAN JACINTO-ANZA	52.8( 85.0)	7.2	0.051	VI
ELSINORE-COYOTE MOUNTAIN	53.1( 85.5)	6.8	0.039	V
SAN JACINTO-COYOTE CREEK	54.7( 88.0)	6.8	0.037	V
SAN JACINTO-SAN JACINTO VALLEY	55.3( 89.0)	6.9	0.040	V
NEWPORT-INGLEWOOD (L.A.Basin)	56.3( 90.6)	6.9	0.039	V
CHINO-CENTRAL AVE. (Elsinore)	59.1( 95.1)	6.7	0.045	VI
WHITTIER	62.6( 100.8)	6.8	0.032	V
SAN JACINTO - BORREGO	64.3( 103.5)	6.6	0.028	V
COMPTON THRUST	65.9( 106.0)	6.8	0.044	VI
ELYSIAN PARK THRUST	69.6( 112.0)	6.7	0.039	V
SAN JACINTO-SAN BERNARDINO	70.3( 113.2)	6.7	0.027	V
SAN ANDREAS - San Bernardino	73.4( 118.1)	7.3	0.039	V
SAN ANDREAS - Southern	73.4( 118.1)	7.4	0.042	VI
SUPERSTITION MTN. (San Jacinto)	78.5( 126.4)	6.6	0.022	IV
SAN ANDREAS - Coachella	79.1( 127.3)	7.1	0.031	V
PINTO MOUNTAIN	79.9( 128.6)	7.0	0.029	V
SAN JOSE	80.0( 128.7)	6.5	0.029	V
ELMORE RANCH	82.5( 132.8)	6.6	0.021	IV
LAGUNA SALADA	83.1( 133.7)	7.0	0.028	V
SUPERSTITION HILLS (San Jacinto)	83.4( 134.3)	6.6	0.021	IV
SIERRA MADRE	83.6( 134.6)	7.0	0.039	V
BURNT MTN.	83.7( 134.7)	6.4	0.018	IV
CUCAMONGA	83.9( 135.1)	7.0	0.039	V
NORTH FRONTAL FAULT ZONE (west)	86.1( 138.5)	7.0	0.038	V
EUREKA PEAK	86.4( 139.0)	6.4	0.018	IV
CLEGHORN	88.1( 141.8)	6.5	0.018	IV
NORTH FRONTAL FAULT ZONE (East)	89.2( 143.5)	6.7	0.029	V
RAYMOND	91.6( 147.4)	6.5	0.025	V
SAN ANDREAS - 1857 Rupture	91.8( 147.7)	7.8	0.045	VI
SAN ANDREAS - Mojave	91.8( 147.7)	7.1	0.027	V
CLAMHELL-SAWPIT	93.4( 150.3)	6.5	0.024	V
VERDUGO	94.0( 151.3)	6.7	0.028	V

TEST.OUT

-----  
 DETERMINISTIC SITE PARAMETERS  
 -----

Page 2

ABBREVIATED FAULT NAME	APPROXIMATE DISTANCE mi (km)	ESTIMATED MAX. EARTHQUAKE EVENT		
		MAXIMUM EARTHQUAKE MAG. (Mw)	PEAK SITE ACCEL. g	EST. SITE INTENSITY MOD. MERC.
BRAWLEY SEISMIC ZONE	94.1( 151.5)	6.4	0.016	IV
LANDERS	94.6( 152.3)	7.3	0.030	V
HOLLYWOOD	95.7( 154.0)	6.4	0.022	IV
HELENDALE - S. LOCKHARDT	97.7( 157.2)	7.1	0.025	V
IMPERIAL	99.3( 159.8)	7.0	0.023	IV
SANTA MONICA	100.0( 160.9)	6.6	0.024	V

\*\*\*\*\*  
 -END OF SEARCH- 46 FAULTS FOUND WITHIN THE SPECIFIED SEARCH RADIUS.

THE ROSE CANYON FAULT IS CLOSEST TO THE SITE.  
 IT IS ABOUT 2.9 MILES (4.6 km) AWAY.

LARGEST MAXIMUM-EARTHQUAKE SITE ACCELERATION: 0.4520 g

# APPENDIX C

## EQ SEARCH TABLES



TEST.OUT

```
*****  
*                               *  
*   E Q S E A R C H           *  
*                               *  
*   Version 3.00             *  
*                               *  
*****
```

ESTIMATION OF  
PEAK ACCELERATION FROM  
CALIFORNIA EARTHQUAKE CATALOGS

JOB NUMBER: 11-10035

DATE: 06-29-2011

JOB NAME: HarrisTest Run

EARTHQUAKE-CATALOG-FILE NAME: ALLQUAKE.DAT

MAGNITUDE RANGE:

MINIMUM MAGNITUDE: 5.00  
MAXIMUM MAGNITUDE: 9.00

SITE COORDINATES:

SITE LATITUDE: 32.9992  
SITE LONGITUDE: 117.2773

SEARCH DATES:

START DATE: 1800  
END DATE: 2011

SEARCH RADIUS:

100.0 mi  
160.9 km

ATTENUATION RELATION: 11) Bozorgnia Campbell Niazi (1999) Hor.-Pleist. Soil-Cor.  
UNCERTAINTY (M=Median, S=Sigma): M Number of Sigmas: 0.0  
ASSUMED SOURCE TYPE: DS [SS=Strike-slip, DS=Reverse-slip, BT=Blind-thrust]  
SCOND: 0 Depth Source: A  
Basement Depth: 5.00 km Campbell SSR: 0 Campbell SHR: 0  
COMPUTE PEAK HORIZONTAL ACCELERATION

MINIMUM DEPTH VALUE (km): 3.0



## TEST.OUT

## EARTHQUAKE SEARCH RESULTS

Page 1

FILE CODE	LAT. NORTH	LONG. WEST	DATE	TIME (UTC) H M Sec	DEPTH (km)	QUAKE MAG.	SITE ACC. g	SITE MM INT.	APPROX. DISTANCE mi [km]
DMG	33.0000	117.3000	11/22/1800	2130 0.0	0.0	6.50	0.631	X	1.3( 2.1)
MGI	33.0000	117.0000	09/21/1856	730 0.0	0.0	5.00	0.060	VI	16.1( 25.8)
MGI	32.8000	117.1000	05/25/1803	0 0 0.0	0.0	5.00	0.057	VI	17.2( 27.6)
DMG	32.7000	117.2000	05/27/1862	20 0 0.0	0.0	5.90	0.079	VII	21.1( 34.0)
T-A	32.6700	117.1700	10/21/1862	0 0 0.0	0.0	5.00	0.041	V	23.6( 37.9)
T-A	32.6700	117.1700	12/00/1856	0 0 0.0	0.0	5.00	0.041	V	23.6( 37.9)
T-A	32.6700	117.1700	05/24/1865	0 0 0.0	0.0	5.00	0.041	V	23.6( 37.9)
DMG	32.8000	116.8000	10/23/1894	23 3 0.0	0.0	5.70	0.047	VI	30.9( 49.7)
PAS	32.9710	117.8700	07/13/1986	1347 8.2	6.0	5.30	0.033	V	34.4( 55.3)
DMG	33.2000	116.7000	01/01/1920	235 0.0	0.0	5.00	0.026	V	36.2( 58.2)
MGI	33.2000	116.6000	10/12/1920	1748 0.0	0.0	5.30	0.027	V	41.6( 66.9)
DMG	33.0000	116.4330	06/04/1940	1035 8.3	0.0	5.10	0.020	IV	48.9( 78.7)
DMG	33.7000	117.4000	05/13/1910	620 0.0	0.0	5.00	0.019	IV	48.9( 78.7)
DMG	33.7000	117.4000	05/15/1910	1547 0.0	0.0	6.00	0.035	V	48.9( 78.7)
DMG	33.7000	117.4000	04/11/1910	757 0.0	0.0	5.00	0.019	IV	48.9( 78.7)
DMG	33.6990	117.5110	05/31/1938	83455.4	10.0	5.50	0.025	V	50.2( 80.7)
DMG	33.7100	116.9250	09/23/1963	144152.6	16.5	5.00	0.018	IV	53.1( 85.5)
T-A	32.2500	117.5000	01/13/1877	20 0 0.0	0.0	5.00	0.018	IV	53.3( 85.8)
DMG	33.7500	117.0000	06/06/1918	2232 0.0	0.0	5.00	0.017	IV	54.2( 87.3)
DMG	33.7500	117.0000	04/21/1918	223225.0	0.0	6.80	0.053	VI	54.2( 87.3)
PAS	33.5010	116.5130	02/25/1980	104738.5	13.6	5.50	0.022	IV	56.1( 90.3)
DMG	33.5000	116.5000	09/30/1916	211 0.0	0.0	5.00	0.017	IV	56.7( 91.2)
DMG	33.5750	117.9830	03/11/1933	518 4.0	0.0	5.20	0.018	IV	56.9( 91.6)
DMG	33.8000	117.0000	12/25/1899	1225 0.0	0.0	6.40	0.038	V	57.6( 92.6)
MGI	33.8000	117.6000	04/22/1918	2115 0.0	0.0	5.00	0.016	IV	58.3( 93.9)
DMG	33.6170	117.9670	03/11/1933	154 7.8	0.0	6.30	0.035	V	58.3( 93.9)
DMG	33.3430	116.3460	04/28/1969	232042.9	20.0	5.80	0.025	V	58.8( 94.7)
DMG	32.7000	116.3000	02/24/1892	720 0.0	0.0	6.70	0.044	VI	60.3( 97.1)
DMG	33.6170	118.0170	03/14/1933	19 150.0	0.0	5.10	0.016	IV	60.3( 97.1)
DMG	33.9000	117.2000	12/19/1880	0 0 0.0	0.0	6.00	0.027	V	62.4(100.3)
DMG	33.4000	116.3000	02/09/1890	12 6 0.0	0.0	6.30	0.033	V	62.9(101.2)
DMG	32.8170	118.3500	12/26/1951	04654.0	0.0	5.90	0.025	V	63.4(102.1)
DMG	33.2000	116.2000	05/28/1892	1115 0.0	0.0	6.30	0.032	V	63.8(102.7)
DMG	33.6830	118.0500	03/11/1933	658 3.0	0.0	5.50	0.019	IV	64.9(104.5)
DMG	33.4080	116.2610	03/25/1937	1649 1.8	10.0	6.00	0.026	V	65.1(104.8)
DMG	33.2830	116.1830	03/23/1954	41450.0	0.0	5.10	0.015	IV	66.2(106.6)
DMG	33.2830	116.1830	03/19/1954	102117.0	0.0	5.50	0.019	IV	66.2(106.6)
DMG	33.2830	116.1830	03/19/1954	95429.0	0.0	6.20	0.029	V	66.2(106.6)
DMG	33.2830	116.1830	03/19/1954	95556.0	0.0	5.00	0.014	IV	66.2(106.6)
DMG	33.7000	118.0670	03/11/1933	51022.0	0.0	5.10	0.015	IV	66.4(106.9)
DMG	33.7000	118.0670	03/11/1933	85457.0	0.0	5.10	0.015	IV	66.4(106.9)
DMG	33.1900	116.1290	04/09/1968	22859.1	11.1	6.40	0.032	V	67.7(109.0)
DMG	33.2170	116.1330	08/15/1945	175624.0	0.0	5.70	0.021	IV	67.9(109.2)

Page 2

TEST.OUT

DMG	34.0000	117.2500	07/23/1923	73026.0	0.0	6.25	0.029	V	69.1(111.2)
DMG	32.2000	116.5500	11/05/1949	43524.0	0.0	5.10	0.014	IV	69.5(111.9)
DMG	32.2000	116.5500	11/04/1949	204238.0	0.0	5.70	0.020	IV	69.5(111.9)
DMG	33.7500	118.0830	03/11/1933	230 0.0	0.0	5.10	0.014	IV	69.6(112.0)
DMG	33.7500	118.0830	03/13/1933	131828.0	0.0	5.30	0.016	IV	69.6(112.0)
DMG	33.7500	118.0830	03/11/1933	323 0.0	0.0	5.00	0.013	III	69.6(112.0)
DMG	33.7500	118.0830	03/11/1933	2 9 0.0	0.0	5.00	0.013	III	69.6(112.0)
DMG	33.7500	118.0830	03/11/1933	910 0.0	0.0	5.10	0.014	IV	69.6(112.0)
DMG	33.9500	116.8500	09/28/1946	719 9.0	0.0	5.00	0.013	III	70.1(112.8)
DMG	32.0000	117.5000	05/01/1939	2353 0.0	0.0	5.00	0.013	III	70.2(113.0)

EARTHQUAKE SEARCH RESULTS

Page 2

FILE CODE	LAT. NORTH	LONG. WEST	DATE	TIME (UTC) H M Sec	DEPTH (km)	QUAKE MAG.	SITE ACC. g	SITE MM INT.	APPROX. DISTANCE mi [km]
DMG	32.0000	117.5000	06/24/1939	1627 0.0	0.0	5.00	0.013	III	70.2(113.0)
MGI	34.0000	117.5000	12/16/1858	10 0 0.0	0.0	7.00	0.047	VI	70.3(113.1)
DMG	33.1130	116.0370	04/09/1968	3 353.5	5.0	5.20	0.014	IV	72.2(116.2)
DMG	32.0830	116.6670	11/25/1934	818 0.0	0.0	5.00	0.013	III	72.5(116.7)
DMG	33.7830	118.1330	10/02/1933	91017.6	0.0	5.40	0.016	IV	73.2(117.8)
DMG	32.9670	116.0000	10/21/1942	162519.0	0.0	5.00	0.012	III	74.0(119.1)
DMG	32.9670	116.0000	10/22/1942	181326.0	0.0	5.00	0.012	III	74.0(119.1)
DMG	32.9670	116.0000	10/21/1942	162213.0	0.0	6.50	0.031	V	74.0(119.1)
DMG	32.9670	116.0000	10/21/1942	162654.0	0.0	5.00	0.012	III	74.0(119.1)
DMG	33.9760	116.7210	06/12/1944	104534.7	10.0	5.10	0.013	III	74.7(120.1)
DMG	32.9830	115.9830	05/23/1942	154729.0	0.0	5.00	0.012	III	75.0(120.6)
DMG	33.2310	116.0040	05/26/1957	155933.6	15.1	5.00	0.012	III	75.4(121.3)
DMG	33.9940	116.7120	06/12/1944	111636.0	10.0	5.30	0.014	IV	76.0(122.3)
MGI	34.1000	117.3000	07/15/1905	2041 0.0	0.0	5.30	0.014	IV	76.0(122.3)
DMG	33.7830	118.2500	11/14/1941	84136.3	0.0	5.40	0.015	IV	77.9(125.4)
PAS	33.9980	116.6060	07/08/1986	92044.5	11.7	5.60	0.016	IV	79.1(127.2)
MGI	34.0000	118.0000	12/25/1903	1745 0.0	0.0	5.00	0.011	III	80.7(129.8)
DMG	34.1000	116.8000	10/24/1935	1448 7.6	0.0	5.10	0.012	III	80.8(130.0)
DMG	32.5000	118.5500	02/24/1948	81510.0	0.0	5.30	0.013	III	81.5(131.2)
DMG	33.8500	118.2670	03/11/1933	1425 0.0	0.0	5.00	0.011	III	81.9(131.8)
GSP	34.1400	117.7000	02/28/1990	234336.6	5.0	5.20	0.012	III	82.4(132.7)
DMG	31.8110	117.1310	12/22/1964	205433.2	2.3	5.60	0.016	IV	82.5(132.7)
DMG	33.9330	116.3830	12/04/1948	234317.0	0.0	6.50	0.028	V	82.5(132.8)
DMG	34.1000	116.7000	02/07/1889	520 0.0	0.0	5.30	0.013	III	82.9(133.5)
DMG	34.2000	117.4000	07/22/1899	046 0.0	0.0	5.50	0.015	IV	83.2(133.9)
PAS	33.0130	115.8390	11/24/1987	131556.5	2.4	6.00	0.020	IV	83.3(134.0)
DMG	34.0170	116.5000	07/24/1947	221046.0	0.0	5.50	0.015	IV	83.3(134.1)
DMG	34.0170	116.5000	07/26/1947	24941.0	0.0	5.10	0.012	III	83.3(134.1)
DMG	34.0170	116.5000	07/25/1947	61949.0	0.0	5.20	0.012	III	83.3(134.1)
DMG	34.0170	116.5000	07/25/1947	04631.0	0.0	5.00	0.011	III	83.3(134.1)
DMG	33.1830	115.8500	04/25/1957	222412.0	0.0	5.10	0.012	III	83.5(134.4)
DMG	34.2000	117.1000	09/20/1907	154 0.0	0.0	6.00	0.020	IV	83.5(134.4)
DMG	33.0000	115.8330	01/08/1946	185418.0	0.0	5.40	0.014	IV	83.6(134.6)
GSP	34.1630	116.8550	06/28/1992	144321.0	6.0	5.30	0.013	III	83.9(135.1)
GSP	33.8760	116.2670	06/29/1992	160142.8	1.0	5.20	0.012	III	84.0(135.1)
DMG	34.1800	116.9200	01/16/1930	034 3.6	0.0	5.10	0.012	III	84.1(135.3)
DMG	34.1800	116.9200	01/16/1930	02433.9	0.0	5.20	0.012	III	84.1(135.3)
DMG	33.0330	115.8210	09/30/1971	224611.3	8.0	5.10	0.011	III	84.3(135.7)
GSP	33.9020	116.2840	07/24/1992	181436.2	9.0	5.00	0.011	III	84.6(136.2)

Page 3

TEST.OUT

GSP	34.1950	116.8620	08/17/1992	204152.1	11.0	5.30	0.013	III	85.9(138.3)
DMG	33.2160	115.8080	04/25/1957	215738.7	-0.3	5.20	0.012	III	86.3(138.9)
GSP	33.9610	116.3180	04/23/1992	045023.0	12.0	6.10	0.020	IV	86.4(139.0)
PAS	34.0610	118.0790	10/01/1987	144220.0	9.5	5.90	0.018	IV	86.6(139.4)
GSN	34.2030	116.8270	06/28/1992	150530.7	5.0	6.70	0.030	V	87.1(140.1)
PAS	33.0820	115.7750	11/24/1987	15414.5	4.9	5.80	0.017	IV	87.1(140.2)
PAS	34.0730	118.0980	10/04/1987	105938.2	8.2	5.30	0.012	III	87.9(141.5)
DMG	31.8670	116.5710	02/27/1937	12918.4	10.0	5.00	0.010	III	88.3(142.2)
T-A	34.0000	118.2500	03/26/1860	0 0 0.0	0.0	5.00	0.010	III	88.9(143.1)
T-A	34.0000	118.2500	01/10/1856	0 0 0.0	0.0	5.00	0.010	III	88.9(143.1)
T-A	34.0000	118.2500	09/23/1827	0 0 0.0	0.0	5.00	0.010	III	88.9(143.1)
DMG	34.2700	117.5400	09/12/1970	143053.0	8.0	5.40	0.013	III	89.0(143.3)
GSP	34.2390	116.8370	07/09/1992	014357.6	0.0	5.30	0.012	III	89.3(143.6)
DMG	34.2670	116.9670	08/29/1943	34513.0	0.0	5.50	0.014	III	89.3(143.8)

EARTHQUAKE SEARCH RESULTS

Page 3

FILE CODE	LAT. NORTH	LONG. WEST	DATE	TIME (UTC) H M Sec	DEPTH (km)	QUAKE MAG.	SITE ACC. g	SITE MM INT.	APPROX. DISTANCE mi [km]
DMG	32.9830	115.7330	01/24/1951	717 2.6	0.0	5.60	0.014	IV	89.4(143.9)
MGI	34.1000	118.1000	07/11/1855	415 0.0	0.0	6.30	0.022	IV	89.5(144.1)
GSP	34.0290	116.3210	08/21/1993	014638.4	9.0	5.00	0.010	III	89.9(144.7)
DMG	34.2000	117.9000	08/28/1889	215 0.0	0.0	5.50	0.013	III	90.3(145.3)
DMG	32.9500	115.7170	06/14/1953	41729.9	0.0	5.50	0.013	III	90.4(145.5)
GSP	34.0640	116.3610	09/15/1992	084711.3	9.0	5.20	0.011	III	90.5(145.6)
DMG	34.3000	117.5000	07/22/1899	2032 0.0	0.0	6.50	0.025	V	90.7(146.0)
MGI	34.0000	118.3000	09/03/1905	540 0.0	0.0	5.30	0.012	III	90.8(146.1)
T-A	33.5000	115.8200	05/00/1868	0 0 0.0	0.0	6.30	0.022	IV	91.0(146.4)
PDG	34.2900	116.9460	02/10/2001	210505.8	9.0	5.10	0.011	III	91.1(146.7)
GSP	34.1080	116.4040	06/29/1992	141338.8	9.0	5.40	0.013	III	91.6(147.4)
DMG	34.0670	116.3330	05/18/1940	72132.7	0.0	5.00	0.010	III	91.6(147.4)
DMG	34.0670	116.3330	05/18/1940	55120.2	0.0	5.20	0.011	III	91.6(147.4)
DMG	32.9000	115.7000	10/02/1928	19 1 0.0	0.0	5.00	0.010	III	91.6(147.5)
DMG	33.2330	115.7170	10/22/1942	15038.0	0.0	5.50	0.013	III	91.7(147.5)
DMG	34.3000	117.6000	07/30/1894	512 0.0	0.0	6.00	0.018	IV	91.7(147.6)
GSP	34.1390	116.4310	06/28/1992	123640.6	10.0	5.10	0.010	III	92.5(148.9)
DMG	34.0830	116.3000	05/18/1940	5 358.5	0.0	5.40	0.012	III	93.6(150.6)
MGI	34.0800	118.2600	07/16/1920	18 8 0.0	0.0	5.00	0.010	III	93.6(150.7)
GSP	34.3400	116.9000	11/27/1992	160057.5	1.0	5.30	0.011	III	95.1(153.0)
PAS	33.0980	115.6320	04/26/1981	12 928.4	3.8	5.70	0.014	IV	95.5(153.6)
GSN	34.2010	116.4360	06/28/1992	115734.1	1.0	7.60	0.052	VI	96.0(154.6)
GSP	34.2620	118.0020	06/28/1991	144354.5	11.0	5.40	0.012	III	96.6(155.5)
DMG	34.3700	117.6500	12/08/1812	15 0 0.0	0.0	7.00	0.033	V	97.0(156.2)
GSP	34.3690	116.8970	12/04/1992	020857.5	3.0	5.30	0.011	III	97.1(156.2)
DMG	31.7500	116.5000	04/29/1935	20 8 0.0	0.0	5.00	0.009	III	97.4(156.8)
DMG	34.0000	118.5000	08/04/1927	1224 0.0	0.0	5.00	0.009	III	98.6(158.7)
MGI	34.0000	118.5000	11/19/1918	2018 0.0	0.0	5.00	0.009	III	98.6(158.7)
DMG	33.1170	115.5670	07/28/1950	175048.0	0.0	5.40	0.011	III	99.3(159.8)
DMG	33.1170	115.5670	07/29/1950	143632.0	0.0	5.50	0.012	III	99.3(159.8)
PAS	33.0140	115.5550	10/16/1979	65842.8	9.1	5.50	0.012	III	99.7(160.5)

\*\*\*\*\*  
 -END OF SEARCH- 137 EARTHQUAKES FOUND WITHIN THE SPECIFIED SEARCH AREA.

TEST.OUT

TIME PERIOD OF SEARCH: 1800 TO 2011

LENGTH OF SEARCH TIME: 212 years

THE EARTHQUAKE CLOSEST TO THE SITE IS ABOUT 1.3 MILES (2.1 km) AWAY.

LARGEST EARTHQUAKE MAGNITUDE FOUND IN THE SEARCH RADIUS: 7.6

LARGEST EARTHQUAKE SITE ACCELERATION FROM THIS SEARCH: 0.631 g

COEFFICIENTS FOR GUTENBERG & RICHTER RECURRENCE RELATION:

a-value= 1.460

b-value= 0.376

beta-value= 0.866

-----  
TABLE OF MAGNITUDES AND EXCEEDANCES:  
-----

Earthquake Magnitude	Number of Times Exceeded	Cumulative No. / Year
4.0	137	0.64623
4.5	137	0.64623
5.0	137	0.64623
5.5	50	0.23585
6.0	26	0.12264
6.5	10	0.04717
7.0	3	0.01415
7.5	1	0.00472

**APPENDIX D**  
**MODIFIED MERCALLI INTENSITY SCALE OF 1931**  
*(Excerpted from the California Division of Conservation Division of Mines  
and Geology DMG Note 32)*

The first scale to reflect earthquake intensities was developed by deRossi of Italy, and Forel of Switzerland, in the 1880s, and is known as the Rossi-Forel Scale. This scale, with values from I to X, was used for about two decades. A need for a more refined scale increased with the advancement of the science of seismology, and in 1902, the Italian seismologist Mercalli devised a new scale on a I to XII range. The Mercalli Scale was modified in 1931 by American seismologists Harry O. Wood and Frank Neumann to take into account modern structural features.

The Modified Mercalli Intensity Scale measures the intensity of an earthquake's effects in a given locality, and is perhaps much more meaningful to the layman because it is based on actual observations of earthquake effects at specific places. It should be noted that because the damage used for assigning intensities can be obtained only from direct firsthand reports, considerable time -- weeks or months -- is sometimes needed before an intensity map can be assembled for a particular earthquake.

On the Modified Mercalli Intensity Scale, values range from I to XII. The most commonly used adaptation covers the range of intensity from the conditions of "I -- not felt except by very few, favorably situated," to "XII -- damage total, lines of sight disturbed, objects thrown into the air." While an earthquake has only one magnitude, it can have many intensities, which decrease with distance from the epicenter.

It is difficult to compare magnitude and intensity because intensity is linked with the particular ground and structural conditions of a given area, as well as distance from the earthquake epicenter, while magnitude depends on the energy released at the focus of the earthquake.

I	Not felt except by a very few under especially favorable circumstances.
II	Felt only by a few persons at rest, especially on upper floors of buildings. Delicately suspended objects may swing.
III	Felt quite noticeably indoors, especially on upper floors of buildings, but many people do not recognize it as an earthquake. Standing motor cars may rock slightly. Vibration like passing of truck. Duration estimated.
IV	During the day felt indoors by many, outdoors by few. At night some awakened. Dishes, windows, doors disturbed; walls make cracking sound. Sensation like heavy truck striking building. Standing motor cars rocked noticeably.
V	Felt by nearly everyone, many awakened. Some dishes, windows, etc., broken; a few instances of cracked plaster; unstable objects overturned. Disturbances of trees, poles, and other tall objects sometimes noticed. Pendulum clocks may stop.
VI	Felt by all, many frightened and run outdoors. Some heavy furniture moved; a few instances of fallen plaster or damaged chimneys. Damage slight.
VII	Everybody runs outdoors. Damage negligible in building of good design and construction; slight to moderate in well-built ordinary structures; considerable in poorly built or badly designed structures; some chimneys broken. Noticed by persons driving motor cars.
VIII	Damage slight in specially designed structures; considerable in ordinary substantial buildings, with partial collapse; great in poorly built structures. Panel walls thrown out of frame structures. Fall of chimneys, factory stacks, columns, monuments, walls. Heavy furniture overturned. Sand and mud ejected in small amounts. Changes in well water. Persons driving motor cars disturbed.
IX	Damage considerable in specially designed structures; well-designed frame structures thrown out of plumb; great in substantial buildings with partial collapse. Buildings shifted off foundations. Ground cracked conspicuously. Underground pipes broken.
X	Some well-built wooden structures destroyed; most masonry and frame structures destroyed with foundations; ground badly cracked. Rails bent. Landslides considerable from riverbanks and steep slopes. Shifted sand and mud. Water splashed (sloped) over banks.
XI	Few, if any, masonry structures remain standing. Bridges destroyed. Broad fissures in ground. Underground pipelines completely out of service. Earth slumps and land slips in soft ground. Rails bent greatly.
XII	Damage total. Practically all works of construction are damaged greatly or destroyed. Waves seen on ground surface. Lines of sight and level are distorted. Objects thrown upward into the air.

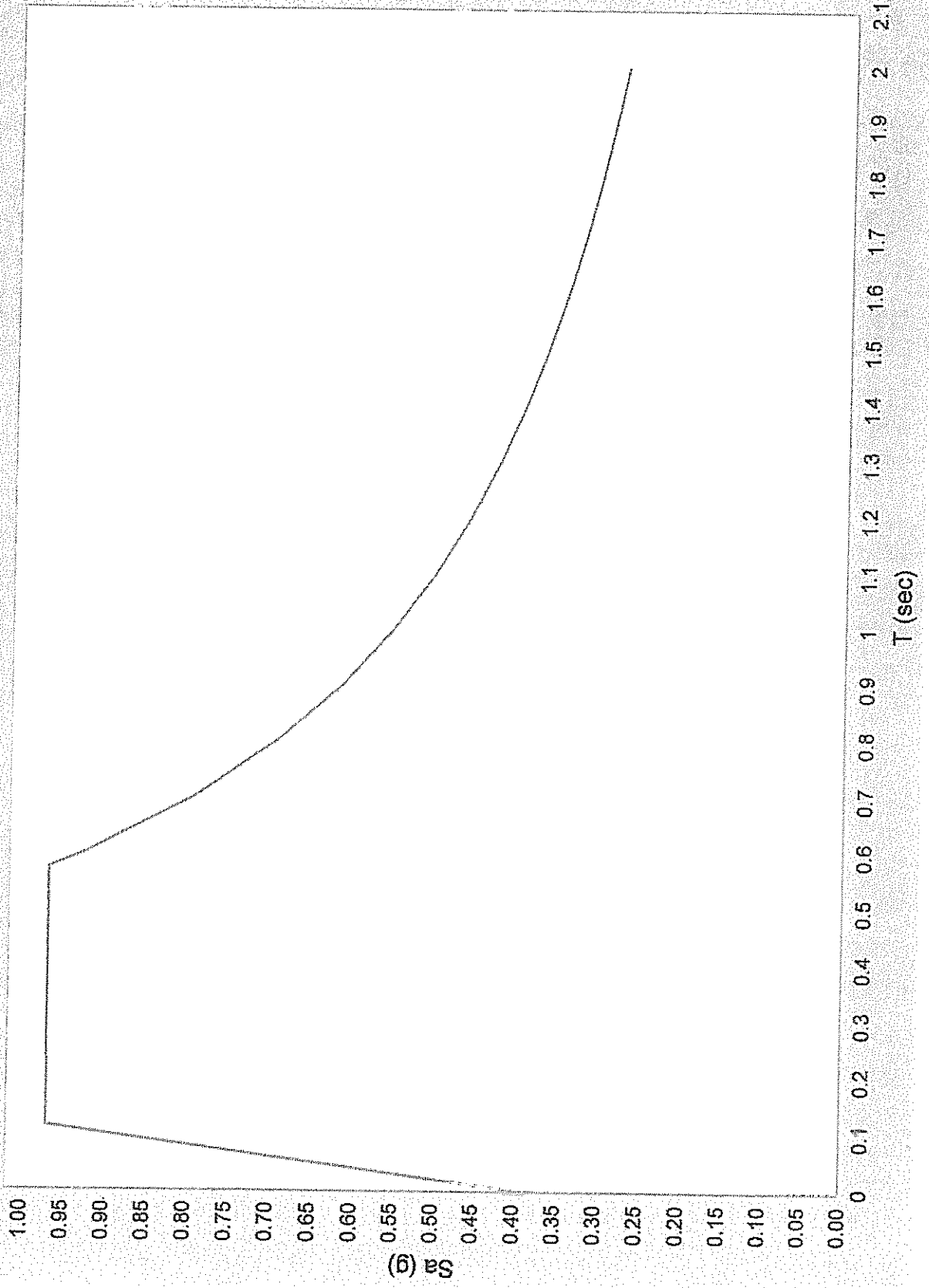


## APPENDIX E

# SPECTRAL ACCELERATION (SA) VS. PERIOD (T)



Design Spectrum Sa Vs T



Harris Property

GEE-Jas N° 11-10038

**APPENDIX F**

**SLOPE STABILITY ANALYSES**





# Harris Res./601 W Circle Dr/Job 11-10035Sectn A-A'

c:\old pc\g72sw\035a20.pl2 Run By: JAC 7/18/2011 07:04AM

124.5

#	FS
a	1.457
b	1.467
c	1.492
d	1.500
e	1.500
f	1.530
g	1.535
h	1.546
i	1.553

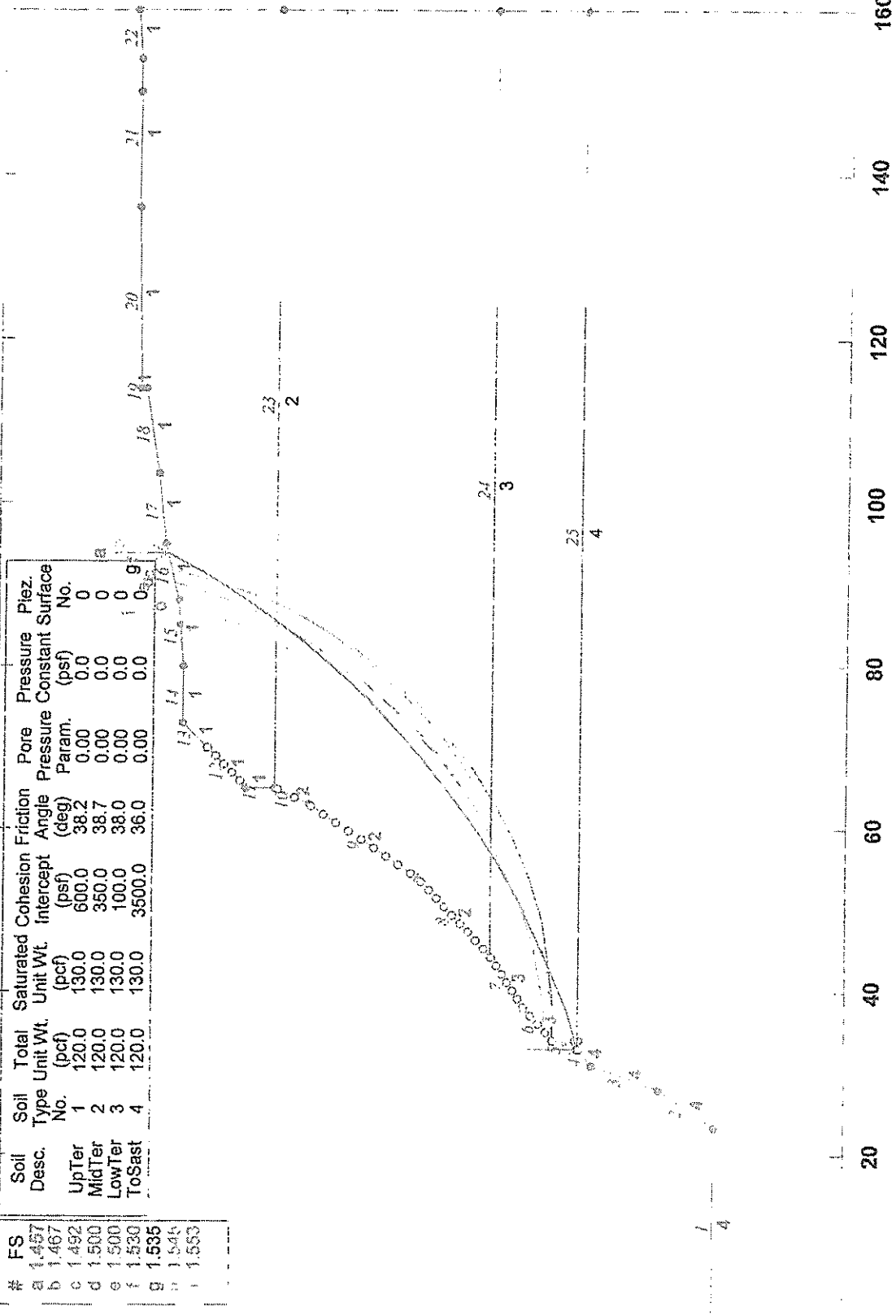
104.5

84.5

64.5

44.5

24.5



160

140

120

100

80

60

40

20

0

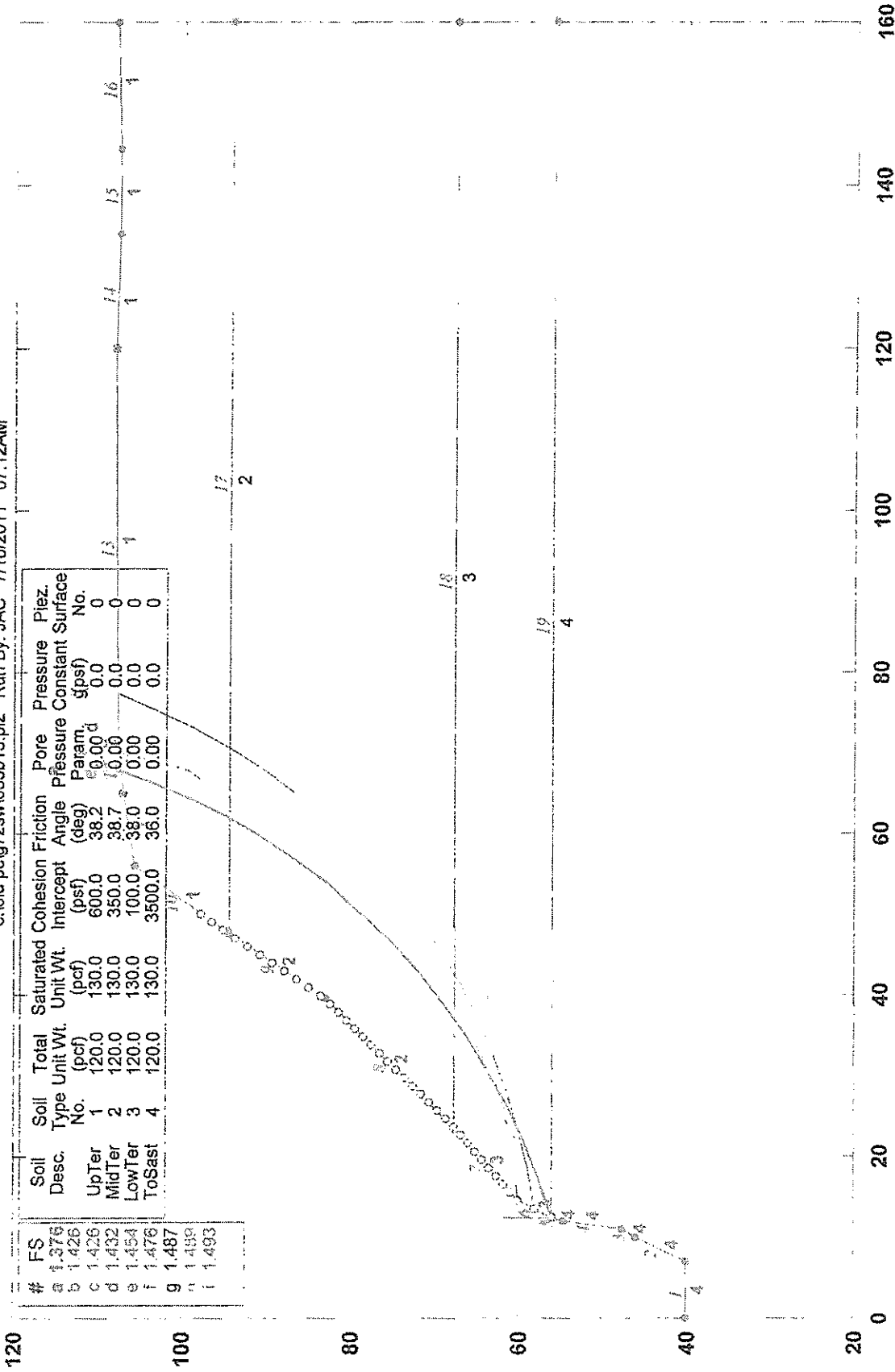
GSTABL7 v.2 FSmin=1.457

Safety Factors Are Calculated By The Modified Bishop Method



# Harris Res./601 W Circle Dr/Job 11-10035Sectn B-B'

c:\old pc\g72sw\035b13.pl2 Run By: JAC 7/18/2011 07:12AM



#	FS	Soil Desc.	Soil Type No.	Total Unit Wt. (pcf)	Saturated Unit Wt. (pcf)	Cohesion (psf)	Friction Angle (deg)	Intercept (psf)	Pore Pressure Param	Pressure Constant (psf)	Piez. No.
a	1.376	UpTer	1	120.0	130.0	600.0	38.2	0.00	0.00	0.00	0
b	1.426	MidTer	2	120.0	130.0	350.0	38.7	0.00	0.00	0.00	0
c	1.432	LowTer	3	120.0	130.0	100.0	38.0	0.00	0.00	0.00	0
d	1.454	ToSast	4	120.0	130.0	3500.0	36.0	0.00	0.00	0.00	0
e	1.476										
f	1.487										
g	1.498										
h	1.493										
i											

GSTABL7 v.2 FSmin=1.376

Safety Factors Are Calculated By The Modified Bishop Method

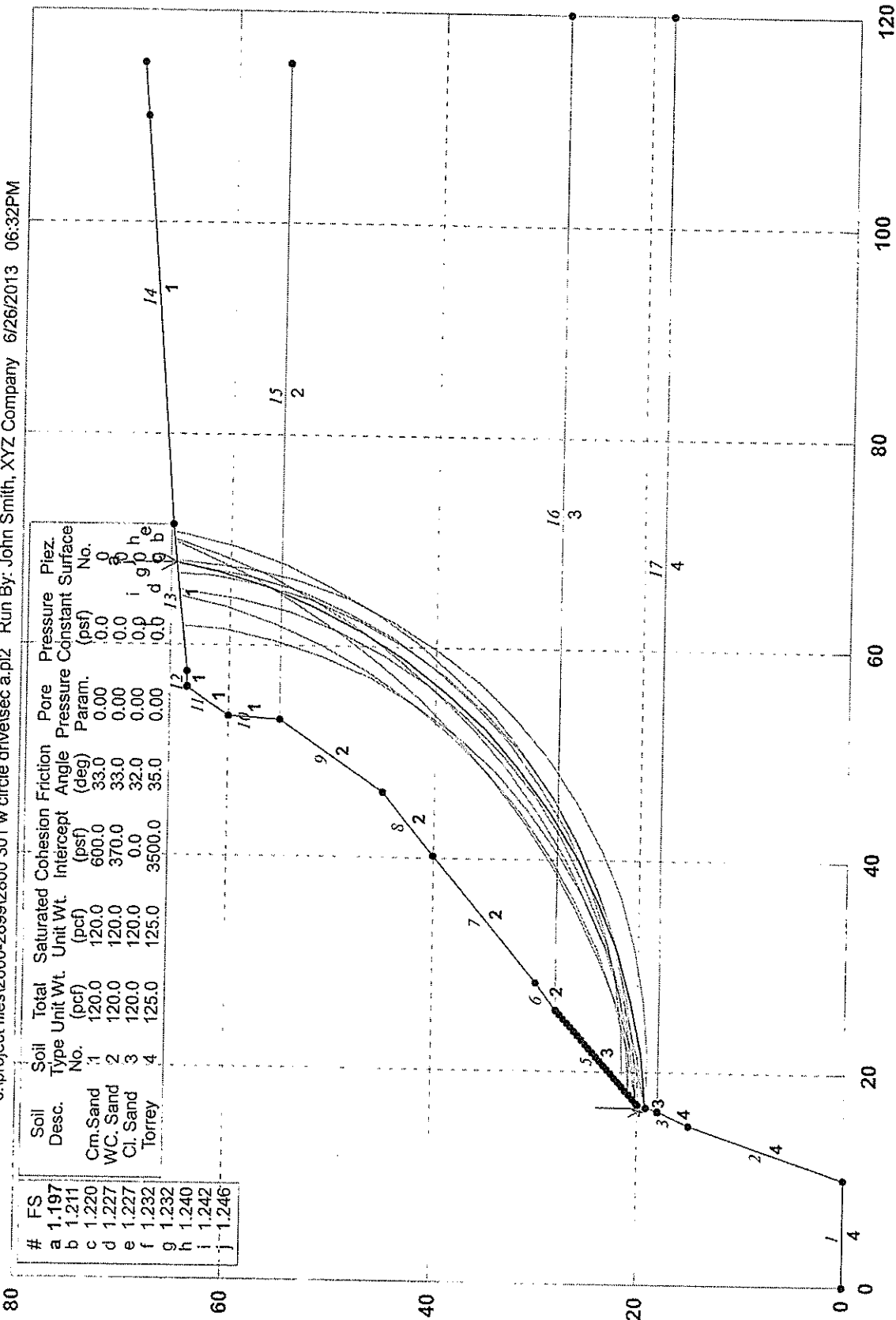


APPENDIX B  
SLOPE STABILITY ANALYSES



# 601 W Circle Drive Section A

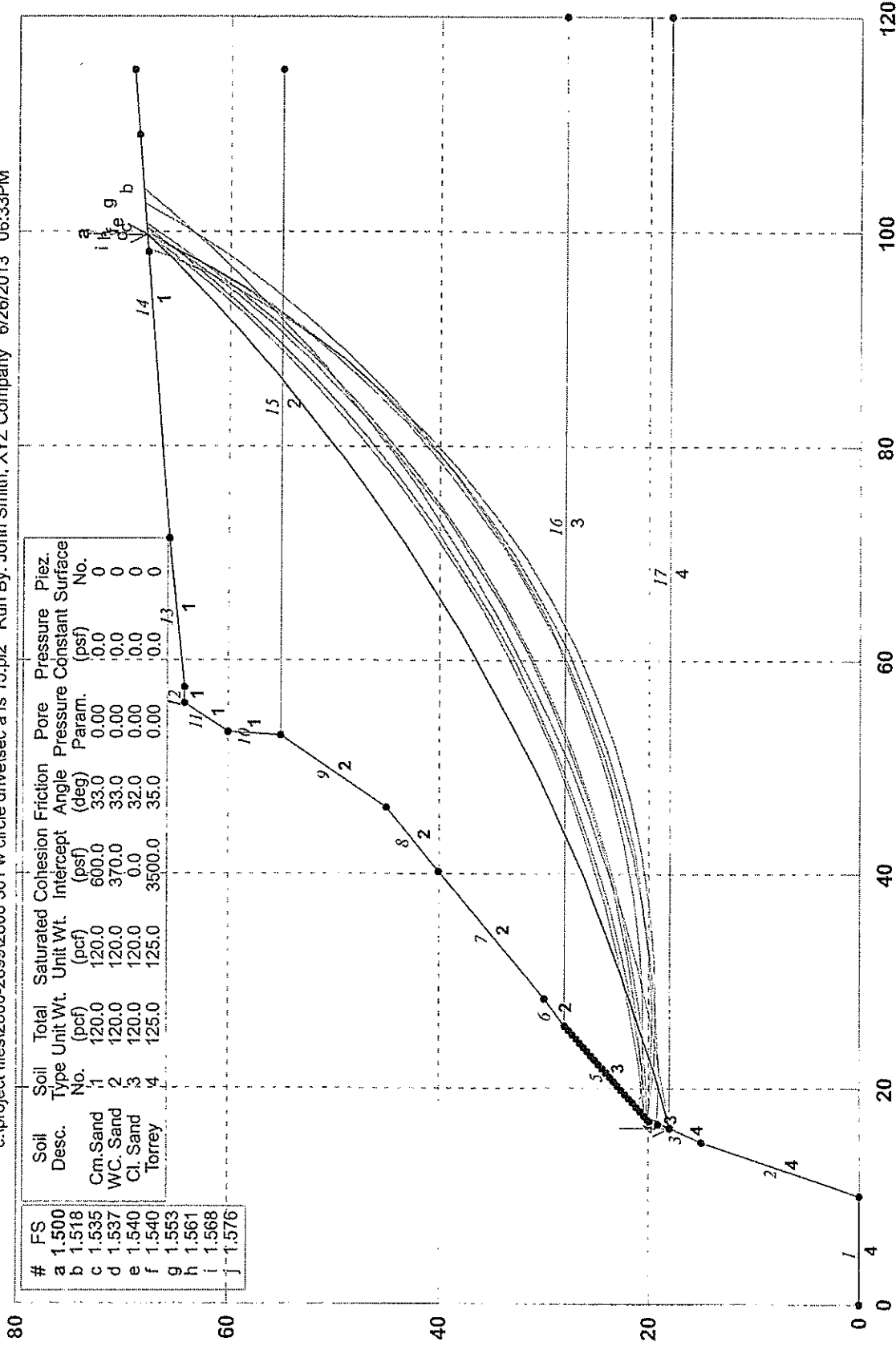
c:\project files\2800-2899\2800 301 w circle drivesecc a.pl2 Run By: John Smith, XYZ Company 6/26/2013 06:32PM



GSTABL7 v.2 FSmin=1.197  
Safety Factors Are Calculated By The Modified Bishop Method

# 601 W Circle Drive Section A

c:\project files\2800-2899\2800 301 w circle drive\sec a fs 15.pl2 Run By: John Smith, XYZ Company 6/26/2013 06:33PM

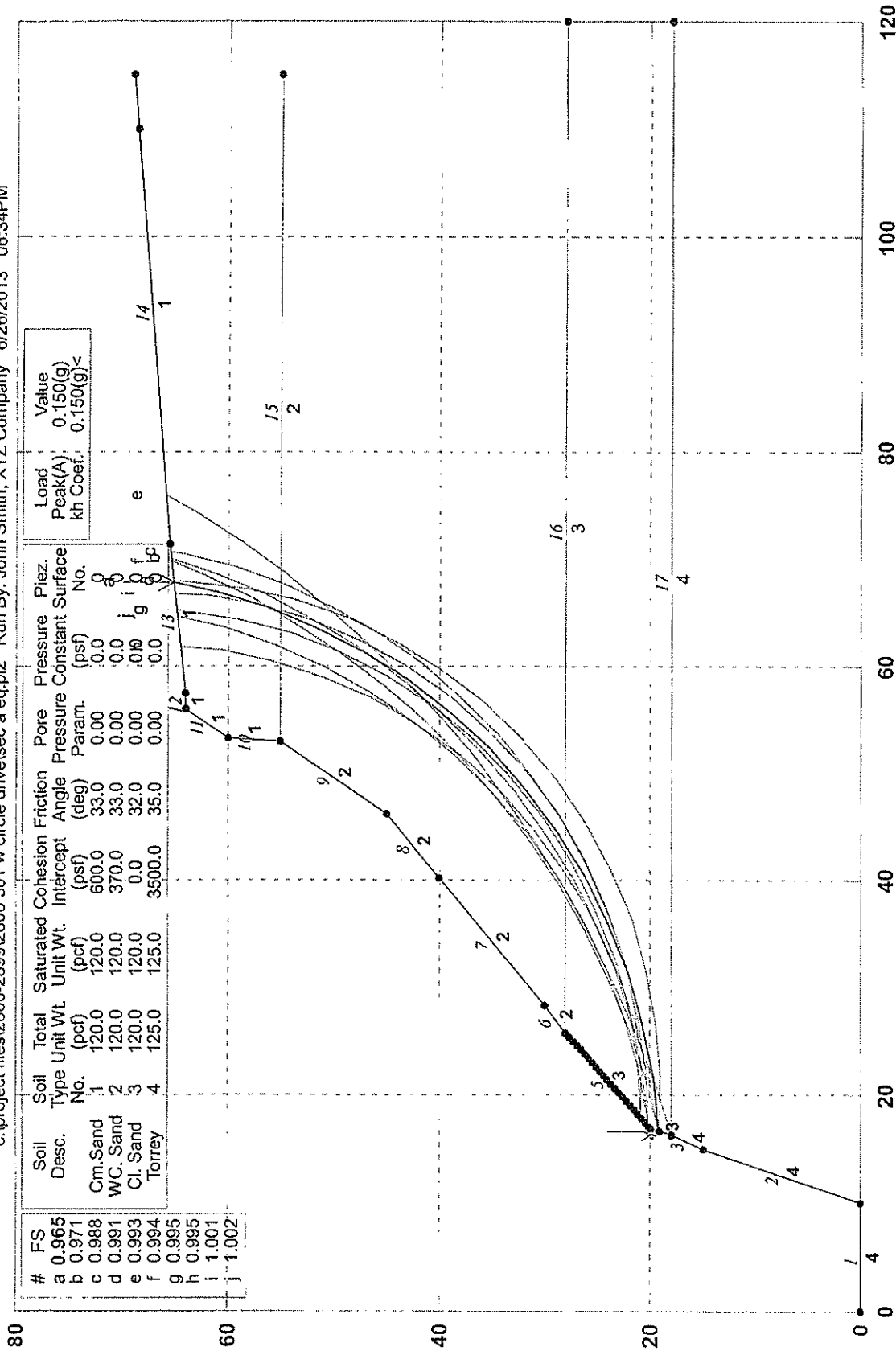


Soil Desc.	Soil Type No.	Total Unit Wt. (pcf)	Saturated Unit Wt. (pcf)	cohesion Intercept (pcf)	Friction Angle (deg)	Pore Pressure Param.	Piez. Constant
Cm. Sand	1	120.0	120.0	600.0	33.0	0.00	0
WC. Sand	2	120.0	120.0	370.0	33.0	0.00	0
Cl. Sand	3	120.0	120.0	0.0	32.0	0.00	0
Torrey	4	125.0	125.0	3500.0	35.0	0.00	0

GSTABL7 v.2 FSmin=1.500  
Safety Factors Are Calculated By The Modified Bishop Method

# 601 W Circle Drive Section A Seismic

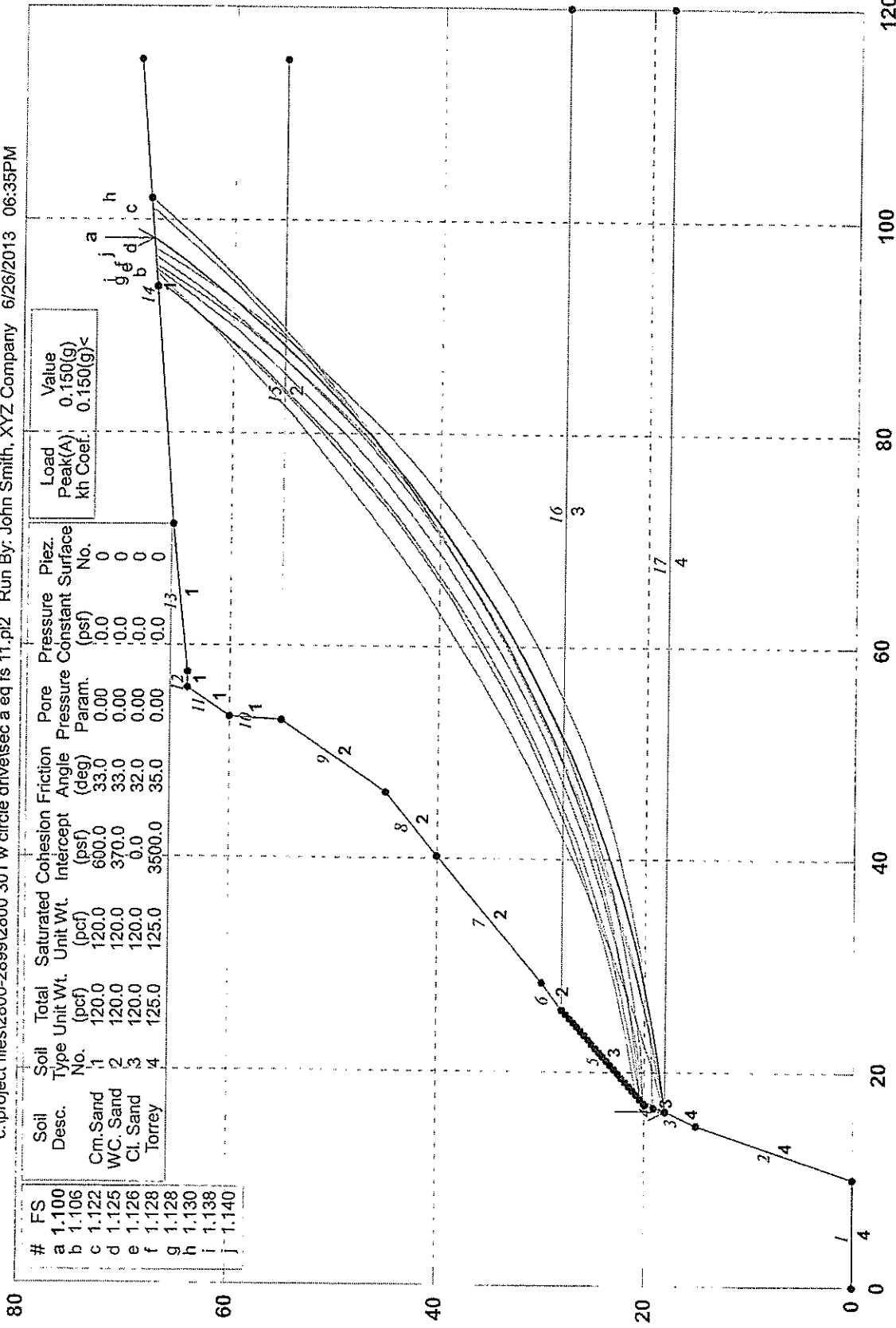
c:\project files\2800-2899\2800 301 w circle drive\sec a eq.pl2 Run By: John Smith, XYZ Company 6/26/2013 06:34PM



GSTABL7 v.2 FSmin=0.965  
 Safety Factors Are Calculated By The Modified Bishop Method

# 601 W Circle Drive Section A Seismic

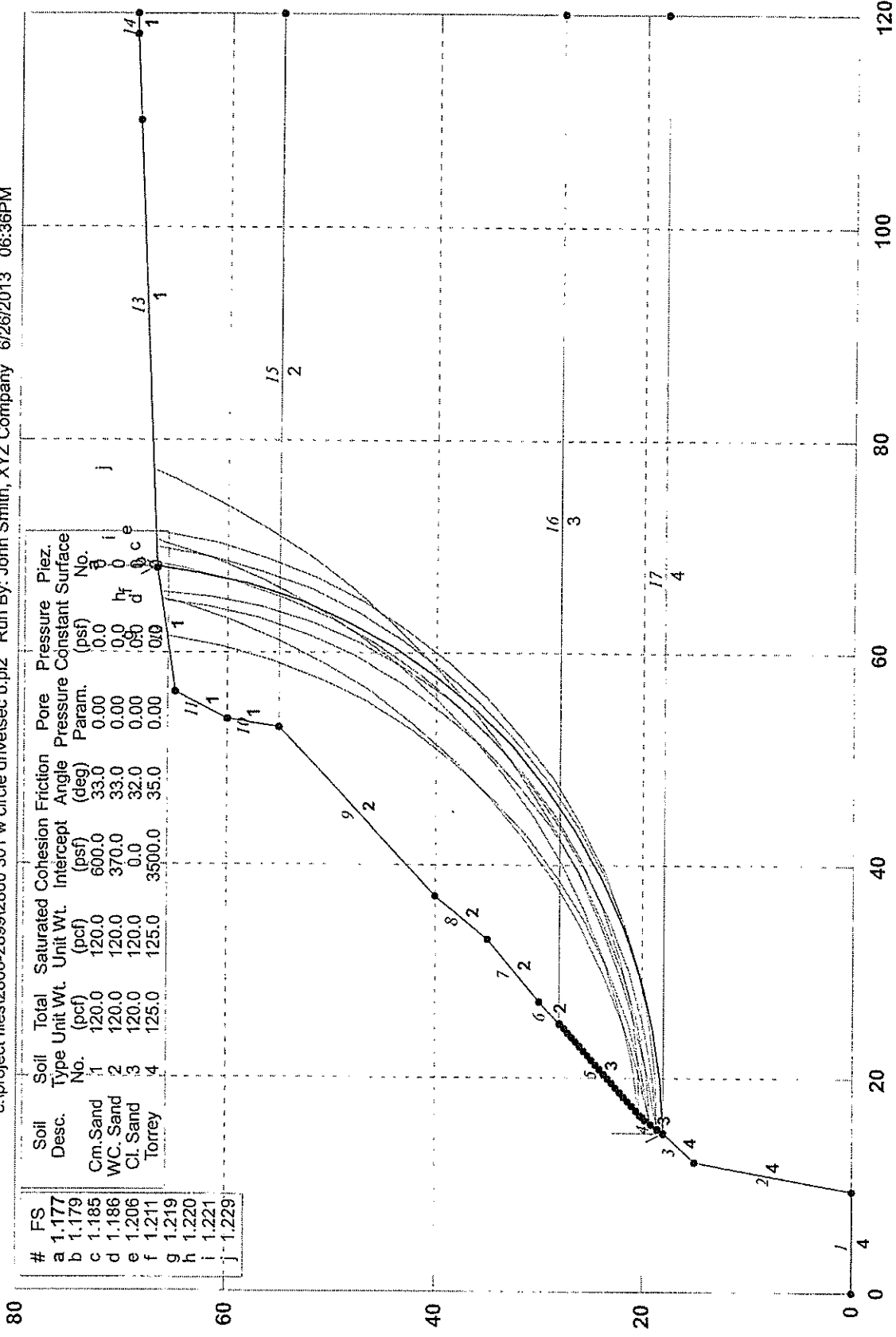
c:\project files\2800-2899\2800 301 w circle drive\sec a eq fs 11.pl2 Run By: John Smith, XYZ Company 6/26/2013 06:35PM



GSTABL7 v.2 FSmin=1.100  
Safety Factors Are Calculated By The Modified Bishop Method

# 601 W Circle Drive Section B

c:\project files\2800-2899\2800 301 w circle driv\sec b.pl2 Run By: John Smith, XYZ Company 6/26/2013 06:36PM



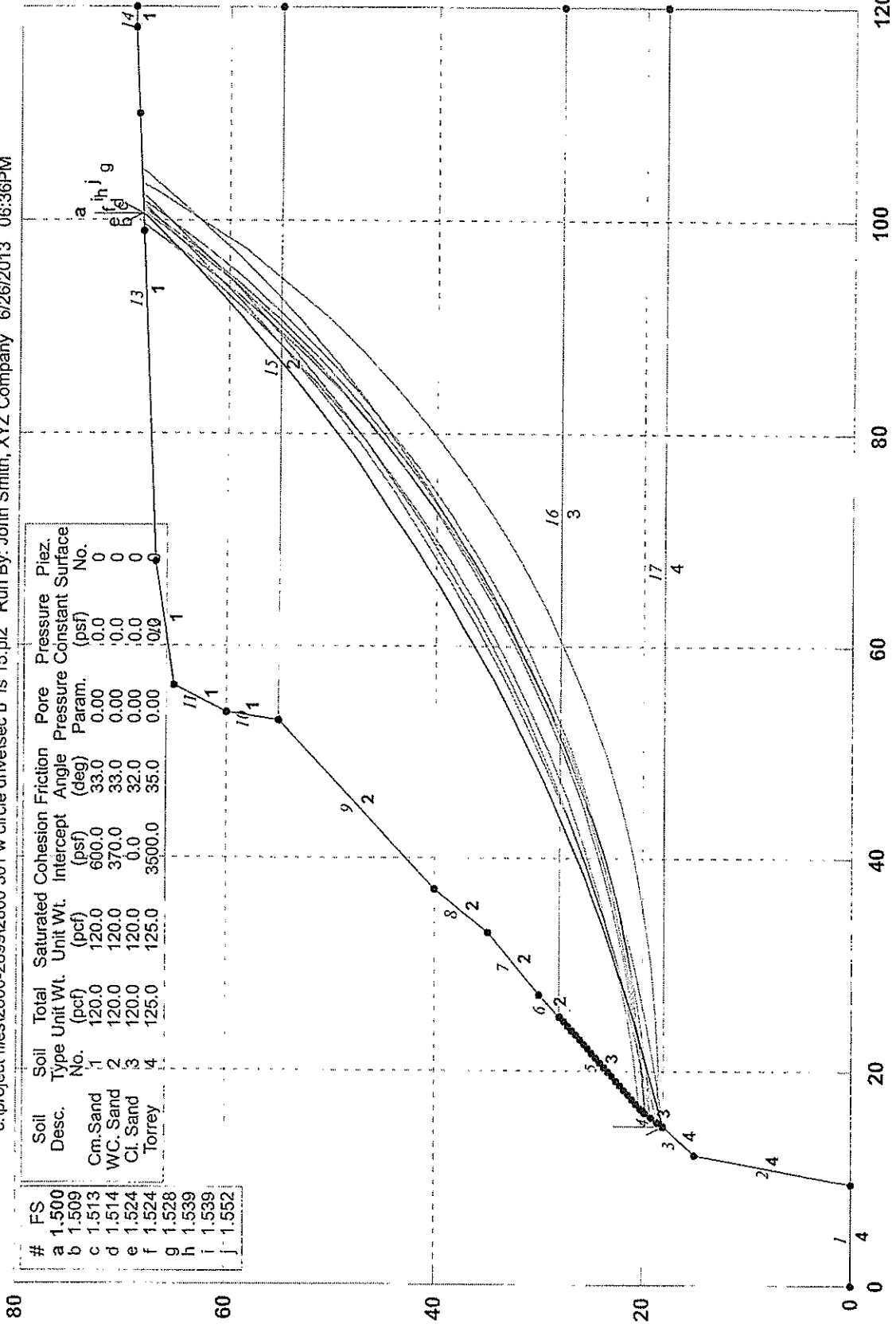
#	FS	Soil Desc.	Soil Type No.	Total Unit Wt. (pcf)	Saturated Unit Wt. (pcf)	Cohesion Intercept (psf)	Friction Angle (deg)	Pore Pressure Param.	Pressure Constant (psf)	Piez. No.
a	1.177	Cm. Sand	1	120.0	120.0	600.0	33.0	0.00	0.0	8
b	1.179	WC. Sand	2	120.0	120.0	370.0	33.0	0.00	0.0	9
c	1.186	Cl. Sand	3	120.0	120.0	0.0	32.0	0.00	0.0	10
d	1.206	Torrey	4	125.0	125.0	3500.0	35.0	0.00	0.0	11
e	1.211									
f	1.219									
g	1.220									
h	1.221									
i	1.221									
j	1.229									

GSTABL7 v.2 FSmin=1.177  
Safety Factors Are Calculated By The Modified Bishop Method



# 601 W Circle Drive Section B

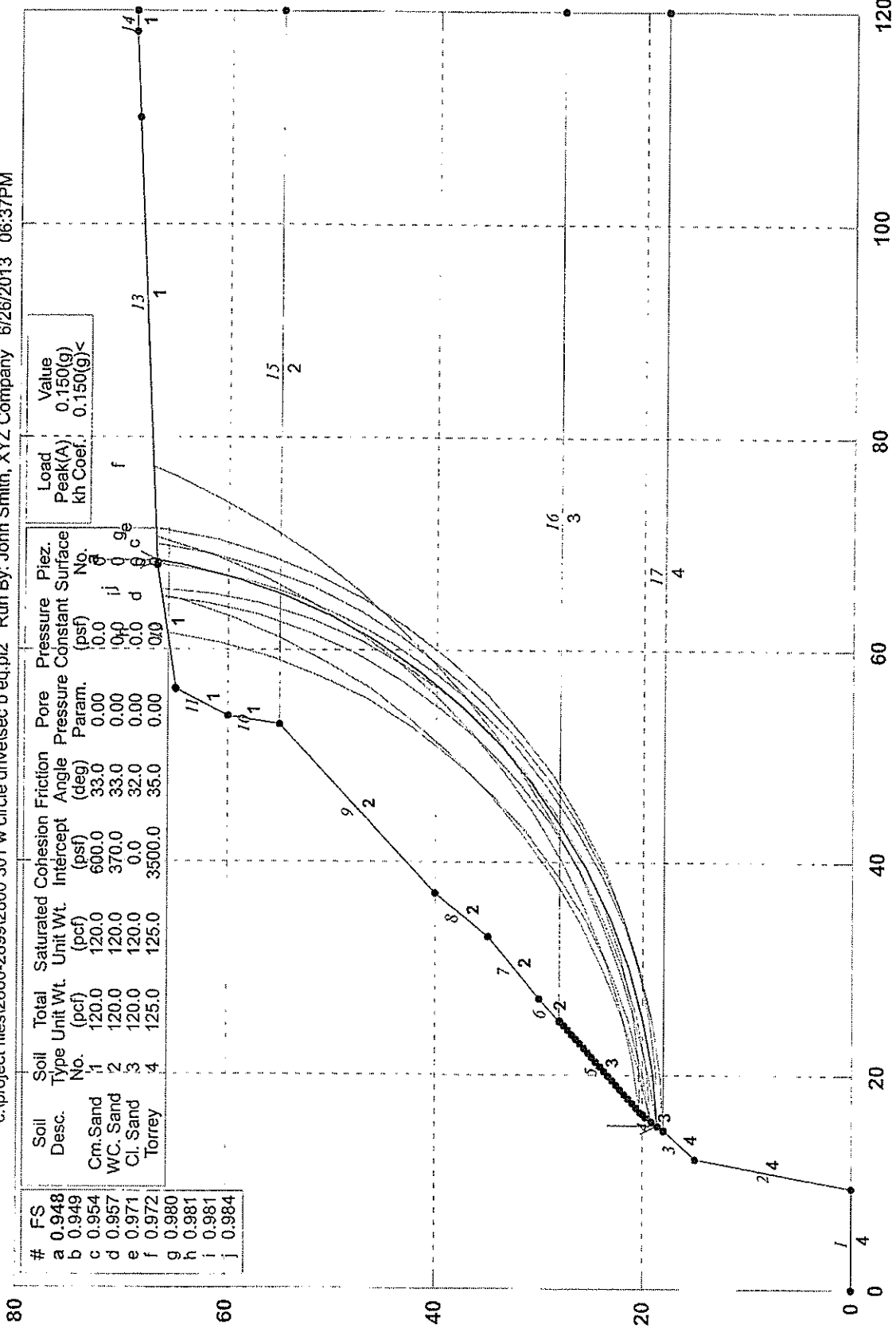
c:\project files\2800-2899\2800 301 w circle drivesecc b fs 15.pl2 Run By: John Smith, XYZ Company 6/26/2013 06:36PM



GSTABL7 v.2 FSmin=1.500  
Safety Factors Are Calculated By The Modified Bishop Method

# 601 W Circle Drive Section B Seismic

c:\project files\2800-2899\2800 301 w circle drivelsec b eq.pl2 Run By: John Smith, XYZ Company 6/26/2013 06:37PM

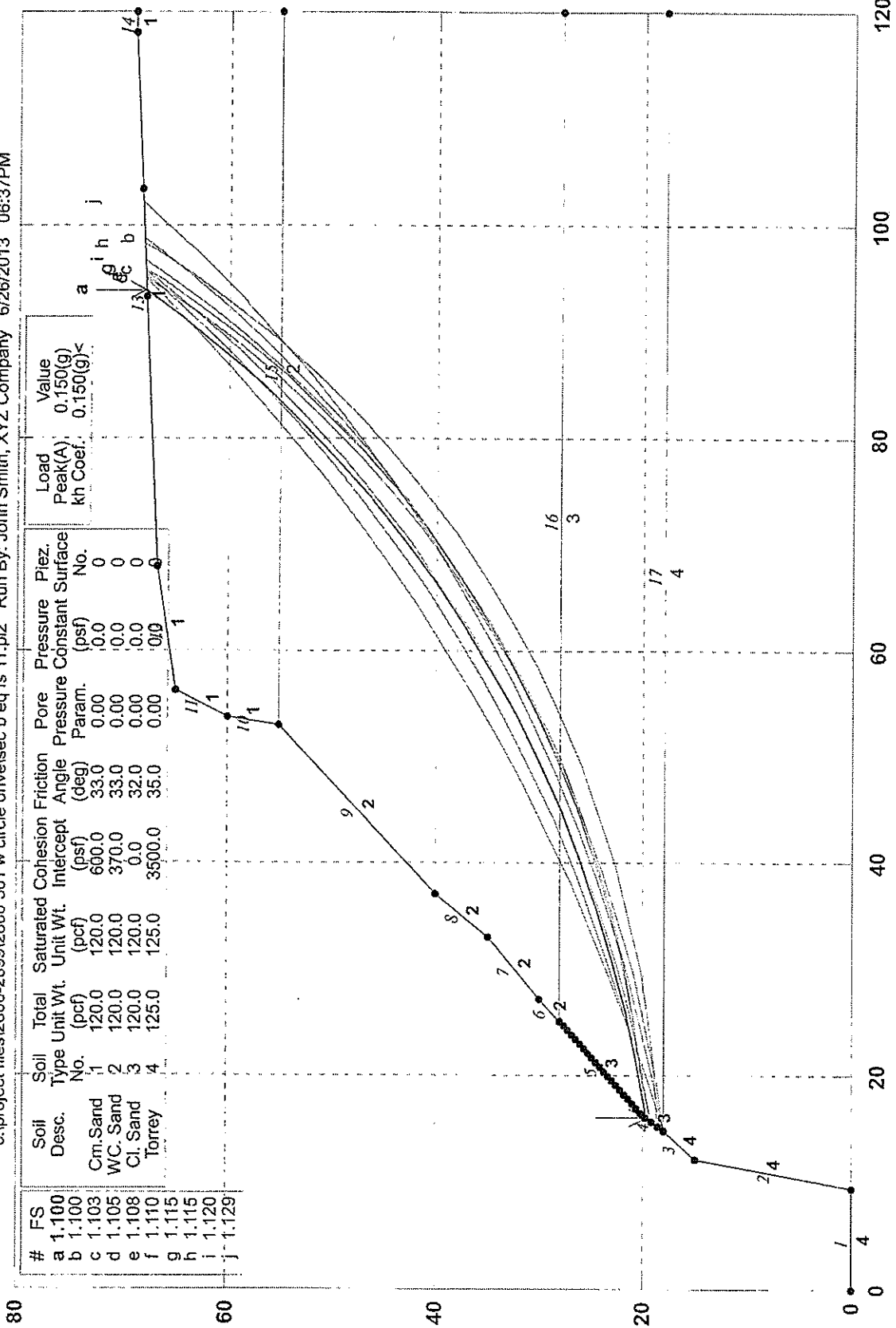


GSTABL7 v.2 FSmin=0.948

Safety Factors Are Calculated By The Modified Bishop Method

# 601 W Circle Drive Section B Seismic

c:\project files\2800-2899\2800 301 w circle drive\sec b eq fs 11.pl2 Run By: John Smith, XYZ Company 6/26/2013 06:37PM

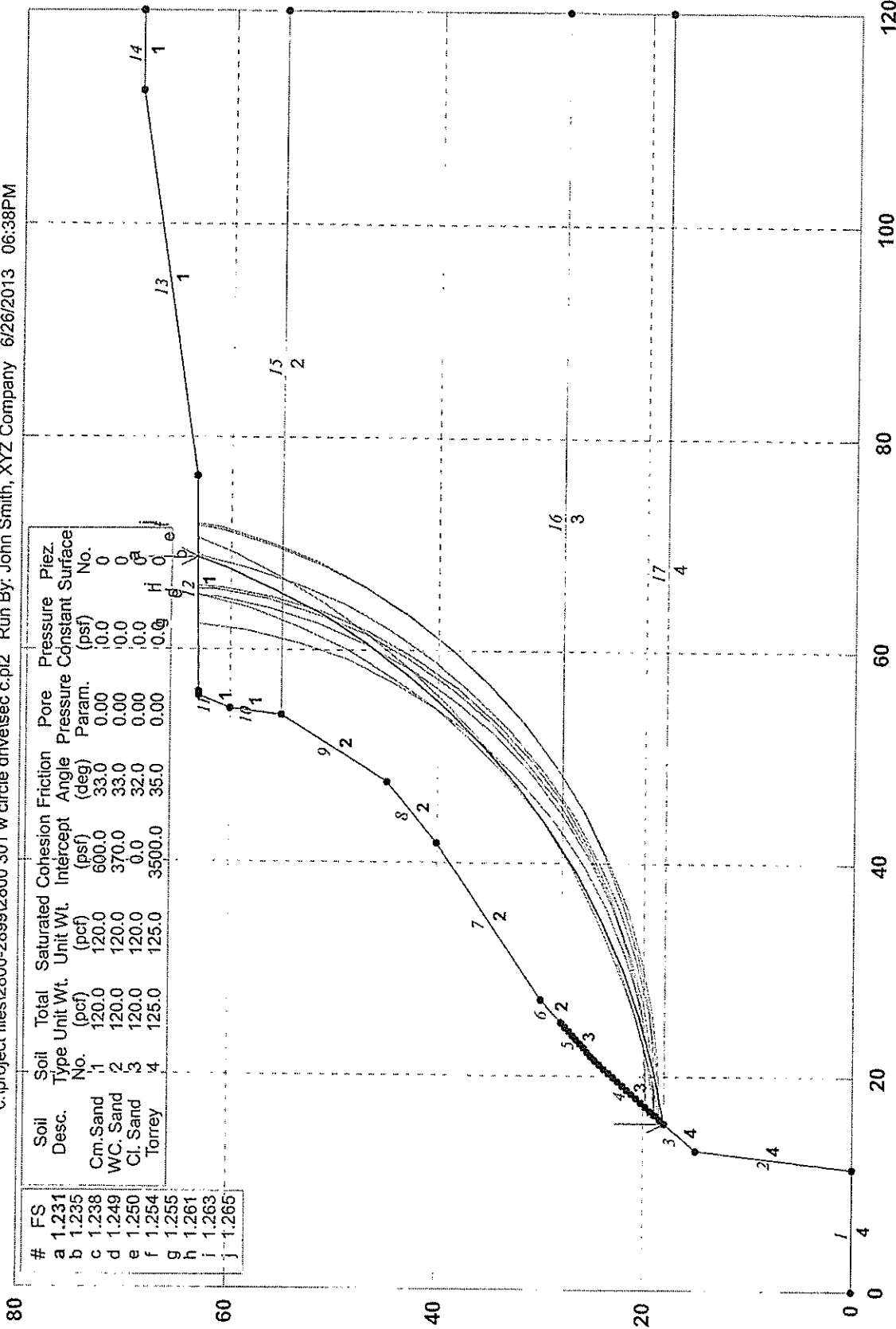


#	FS	Soil Desc.	Soil Type No.	Total Unit Wt. (pcf)	Saturated Unit Wt. (pcf)	Cohesion Intercept (psf)	Friction Angle (deg)	Pore Pressure Param.	Pressure Constant (psf)	Piez. No.	Load Peak(A) kh Coef.	Value
a	1.100											0.150(g)
b	1.103											0.150(g)
c	1.105	Cm.Sand	1	120.0	120.0	600.0	33.0	0.00	0.0	0		
d	1.108	WC.Sand	2	120.0	120.0	370.0	33.0	0.00	0.0	0		
e	1.110	Cl.Sand	3	120.0	120.0	0.0	32.0	0.00	0.0	0		
f	1.115	Torrey	4	125.0	125.0	3500.0	35.0	0.00	0.0	0		
g	1.115											
h	1.115											
i	1.120											
j	1.129											

GSTABL7 v.2 FSmin=1.100  
Safety Factors Are Calculated By The Modified Bishop Method

# 601 W Circle Drive Section C

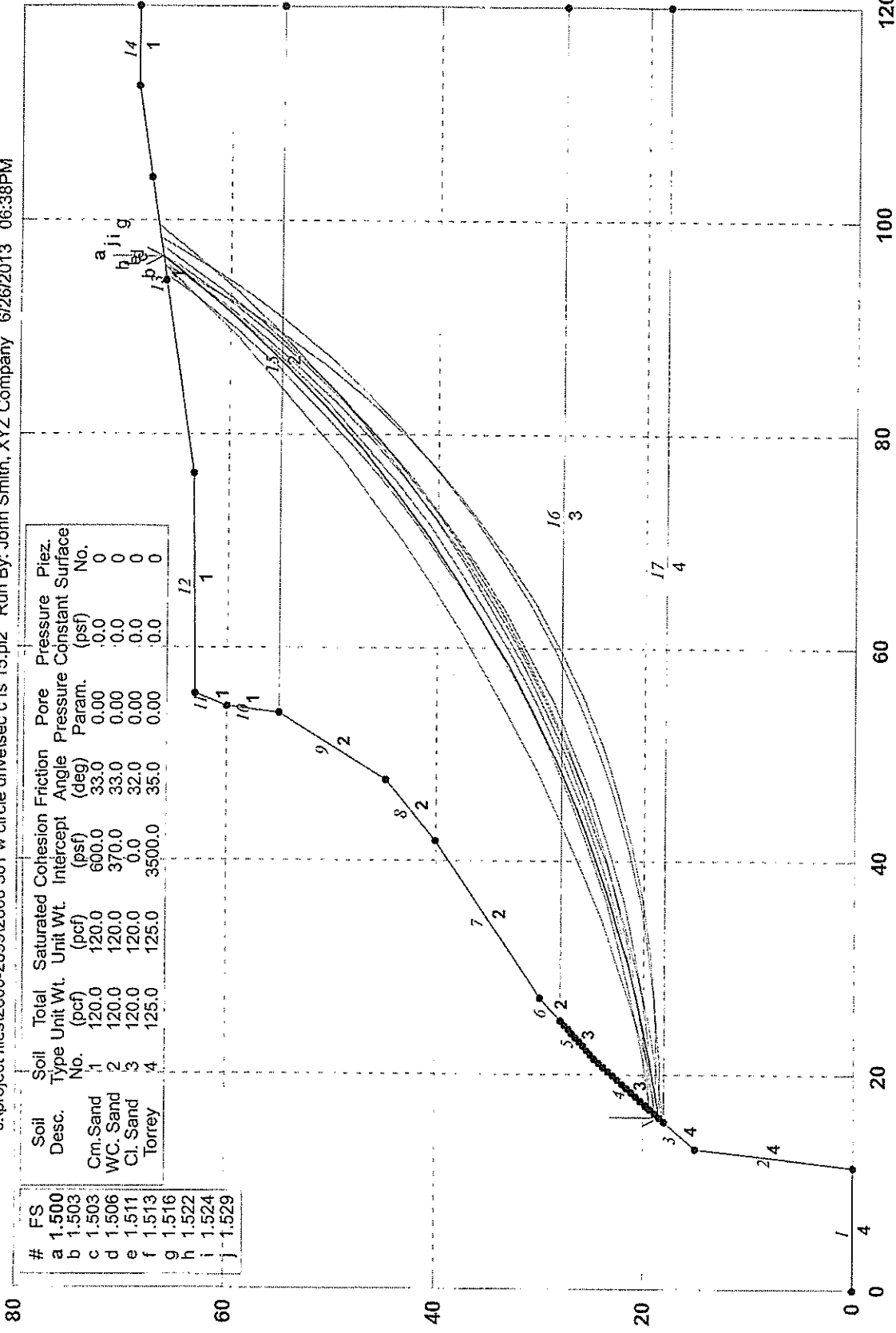
c:\project files\2800-2899\2800 301 w circle drive\sec c.pl2 Run By: John Smith, XYZ Company 6/26/2013 06:38PM



GSTABL7 v.2 FSmin=1.231  
Safety Factors Are Calculated By The Modified Bishop Method

# 601 W Circle Drive Section C

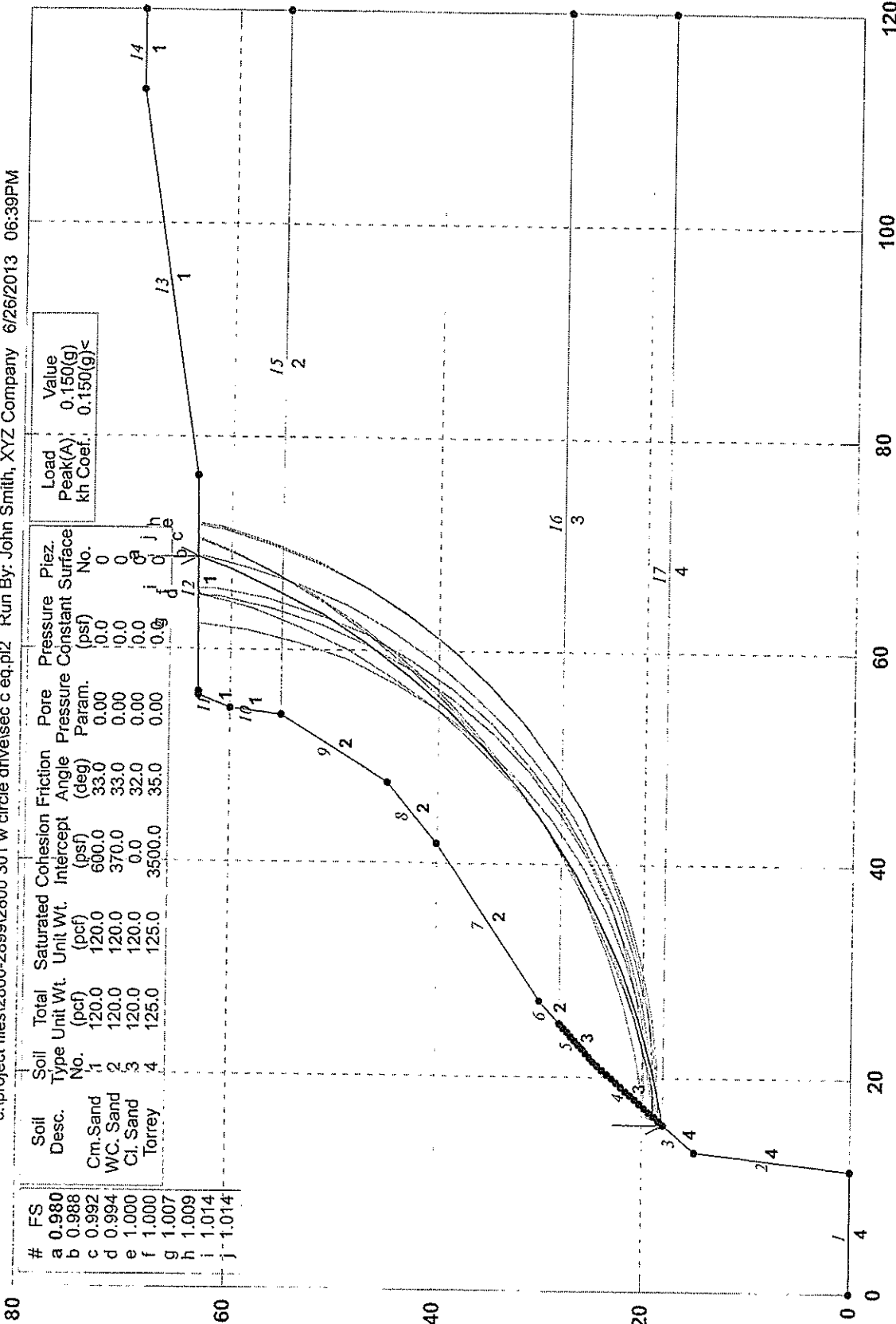
c:\project files\2800-2899\2800 301 w circle drive\sec c fs 15.pl2 Run By: John Smith, XYZ Company 6/26/2013 06:38PM



GSTABL7 v.2 FSmin=1.500  
Safety Factors Are Calculated By The Modified Bishop Method

# 601 W Circle Drive Section C Seismic

c:\project files\2800-2899\2800 301 w circle drive\sec c eq.pl2 Run By: John Smith, XYZ Company 6/26/2013 06:39PM

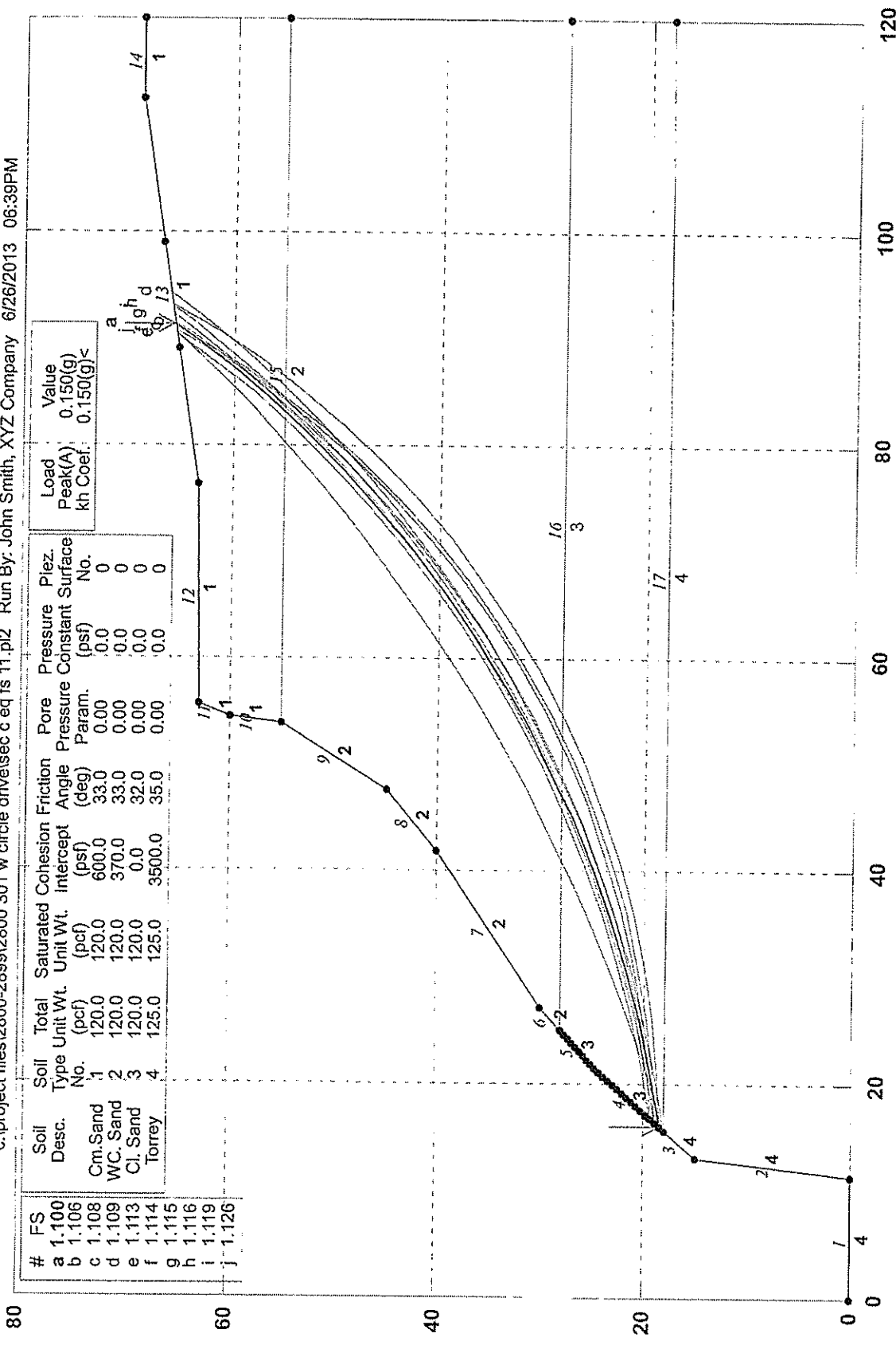


GSTABL7 v.2 FSmin=0.980

Safety Factors Are Calculated By The Modified Bishop Method

# 601 W Circle Drive Section C Seismic

c:\project files\2800-2899\2800 301 w circle drive\sec c eq fs 11.pl2 Run By: John Smith, XYZ Company 6/26/2013 06:39PM



Soil Desc.	Soil Type No.	Total Unit Wt. (pcf)	Saturated Unit Wt. (pcf)	Cohesion Intercept (psf)	Friction Angle (deg)	Pore Pressure Param. (psf)	Pressure Constant (psf)	Piez. No.	Load Peak(A) Kh Coef.	Value
Cm. Sand	1	120.0	120.0	600.0	33.0	0.00	0.0	0	0.150(g)	0.150(g)
WC. Sand	2	120.0	120.0	370.0	33.0	0.00	0.0	0	0.150(g)	0.150(g)
Cl. Sand	3	120.0	120.0	0.0	32.0	0.00	0.0	0	0.150(g)	0.150(g)
Torrey	4	125.0	125.0	3500.0	35.0	0.00	0.0	0	0.150(g)	0.150(g)

#	FS
a	1.100
b	1.106
c	1.108
d	1.109
e	1.113
f	1.114
g	1.115
h	1.116
i	1.119
j	1.126

GSTABL7 v.2 FSmin=1.100

Safety Factors Are Calculated By The Modified Bishop Method

APPENDIX C

EXCERPT FROM NAVFAC DM-7.2





# Naval Facilities Engineering Command

200 Stovall Street  
Alexandria, Virginia 22332-2300

APPROVED FOR PUBLIC RELEASE



# Foundations & Earth Structures

DESIGN MANUAL 7.02  
REVALIDATED BY CHANGE 1 SEPTEMBER 1986

## Section 7. LATERAL LOAD CAPACITY

1. DESIGN CONCEPTS. A pile loaded by lateral thrust and/or moment at its top, resists the load by deflecting to mobilize the reaction of the surrounding soil. The magnitude and distribution of the resisting pressures are a function of the relative stiffness of pile and soil.

Design criteria is based on maximum combined stress in the piling, allowable deflection at the top or permissible bearing on the surrounding soil. Although 1/4-inch at the pile top is often used as a limit, the allowable lateral deflection should be based on the specific requirements of the structure.

## 2. DEFORMATION ANALYSIS - SINGLE PILE.

a. General. Methods are available (e.g., Reference 9 and Reference 31, Non-Dimensional Solutions for Laterally Loaded Piles, with Soil Modulus Assumed Proportional to Depth, by Reese and Matlock) for computing lateral pile load-deformation based on complex soil conditions and/or non-linear soil stress-strain relationships. The COM 622 computer program (Reference 32, Laterally Loaded Piles: Program Documentation, by Reese) has been documented and is widely used. Use of these methods should only be considered when the soil stress-strain properties are well understood.

File deformation and stress can be approximated through application of several simplified procedures based on idealized assumptions. The two basic approaches presented below depend on utilizing the concept of coefficient of lateral subgrade reaction. It is assumed that the lateral load does not exceed about 1/3 of the ultimate lateral load capacity.

b. Granular Soil and Normally to Slightly Overconsolidated Cohesive Soils. Pile deformation can be estimated assuming that the coefficient of subgrade reaction,  $K_h$ , increases linearly with depth in accordance with:

$$K_h = \frac{fz}{D}$$

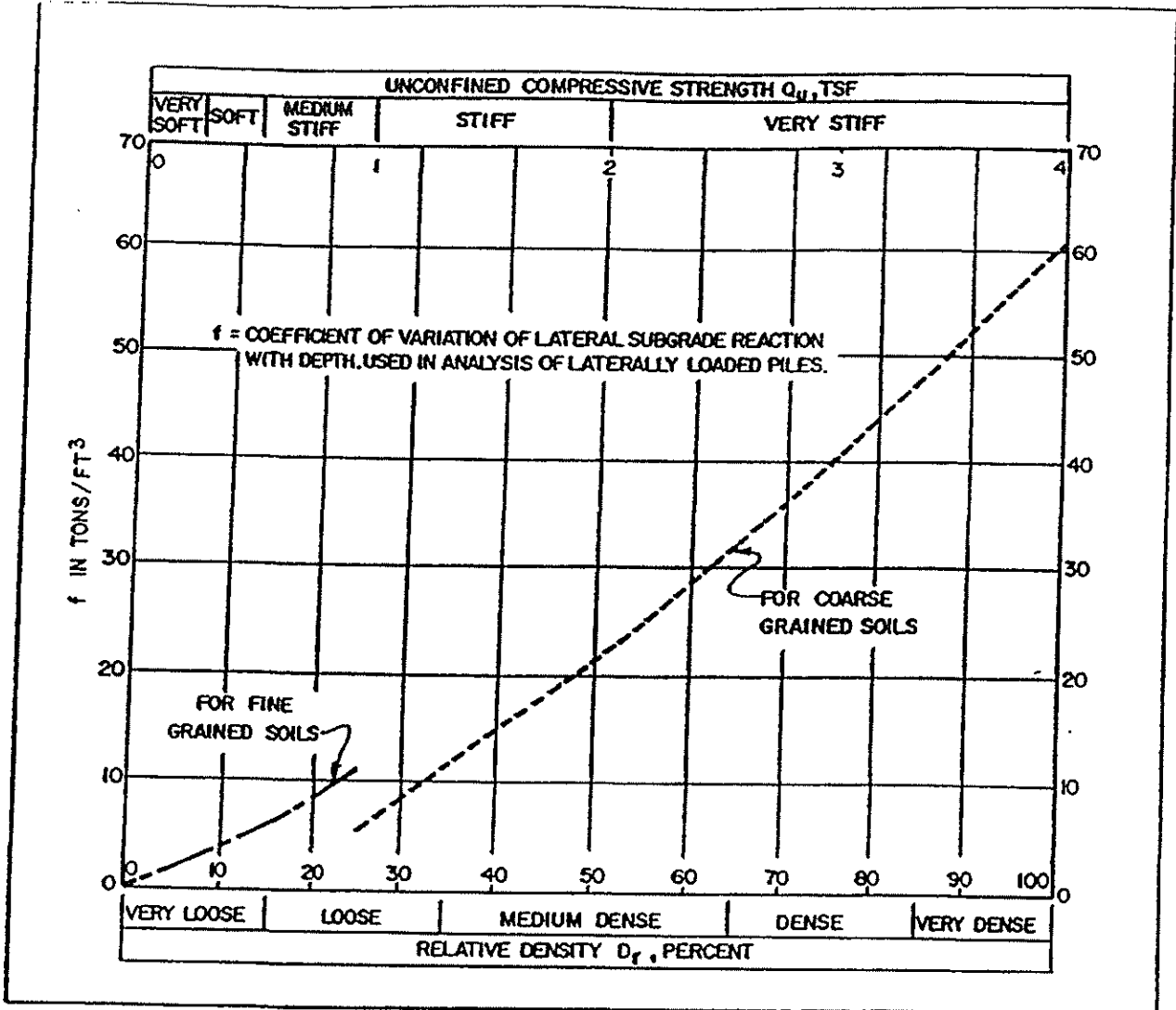
where:  $K_h$  = coefficient of lateral subgrade reaction (tons/ft<sup>3</sup>)  
 $f$  = coefficient of variation of lateral subgrade reaction (tons/ft<sup>3</sup>)  
 $z$  = depth (feet)  
 $D$  = width/diameter of loaded area (feet)

Guidance for selection of  $f$  is given in Figure 9 for fine-grained and coarse-grained soils.

c. Heavily Overconsolidated Cohesive Soils. For heavily overconsolidated hard cohesive soils, the coefficient of lateral subgrade reaction can be assumed to be constant with depth. The methods presented in Chapter 4 can be used for the analysis;  $K_h$  varies between 35c and 70c (units of force/length<sup>3</sup>) where c is the undrained shear strength.

d. Loading Conditions. Three principal loading conditions are illustrated with the design procedures in Figure 10, using the influence diagrams of Figure 11, 12 and 13 (all from Reference 31). Loading may be limited by allowable deflection of pile top or by pile stresses.

Case I. Pile with flexible cap or hinged end condition. Thrust and moment are applied at the top, which is free to rotate. Obtain total deflection, moment, and shear in the pile by algebraic sum of the effects of thrust and moment, given in Figure 11.



**FIGURE 9**  
Coefficient of Variation of Subgrade Reaction

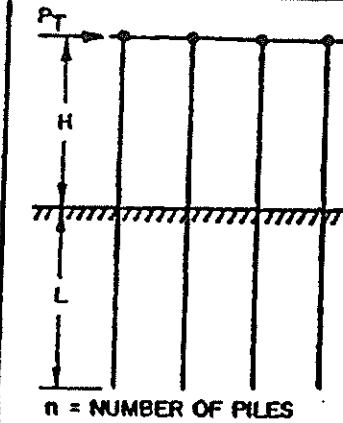
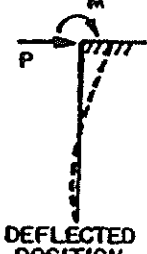
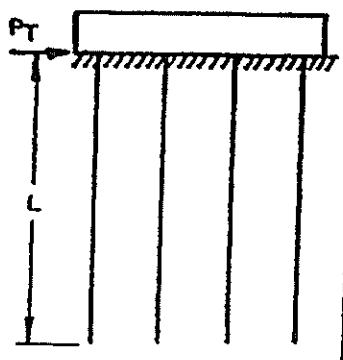

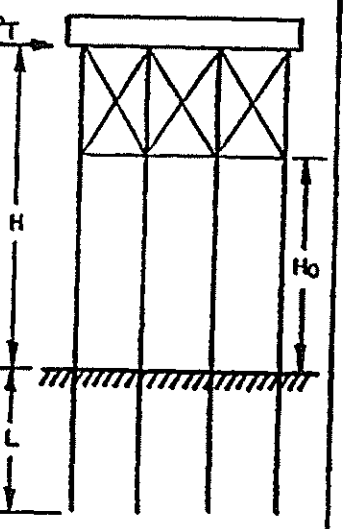
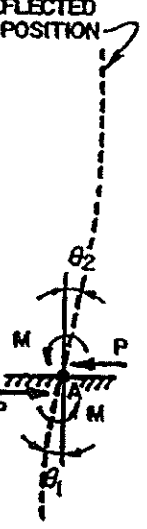
CASE I. FLEXIBLE CAP, ELEVATED POSITION		
CONDITION	LOAD AT GROUND LINE	DESIGN PROCEDURE
 <p><math>n = \text{NUMBER OF PILES}</math></p>	<p>FOR EACH PILE:</p> $P = \frac{P_T}{n}$ $M = PH$  <p>DEFLECTED POSITION</p>	<p>FOR DEFINITION OF PARAMETERS SEE FIGURE 12</p> <ol style="list-style-type: none"> <li>1. COMPUTE RELATIVE STIFFNESS FACTOR. <math display="block">T = \left(\frac{EI}{f}\right)^{1/5}</math></li> <li>2. SELECT CURVE FOR PROPER <math>\frac{L}{T}</math> IN FIGURE 11.</li> <li>3. OBTAIN COEFFICIENTS <math>F_\delta, F_M, F_V</math> AT DEPTHS DESIRED.</li> <li>4. COMPUTE DEFLECTION, MOMENT AND SHEAR AT DESIRED DEPTHS USING FORMULAS OF FIGURE 11.</li> </ol> <p>NOTE: "f" VALUES FROM FIGURE 9 AND CONVERT TO LB/IN<sup>3</sup>.</p>
CASE II. PILES WITH RIGID CAP AT GROUND SURFACE		
		<ol style="list-style-type: none"> <li>1. PROCEED AS IN STEP 1, CASE I.</li> <li>2. COMPUTE DEFLECTION AND MOMENT AT DESIRED DEPTHS USING COEFFICIENTS <math>F_\delta, F_M</math> AND FORMULAS OF FIGURE 12.</li> <li>3. MAXIMUM SHEAR OCCURS AT TOP OF PILE AND EQUALS <math>P = \frac{P_T}{n}</math> IN EACH PILE.</li> </ol>
CASE III. RIGID CAP, ELEVATED POSITION		
	<p>DEFLECTED POSITION</p> 	<ol style="list-style-type: none"> <li>1. ASSUME A HINGE AT POINT A WITH A BALANCING MOMENT M APPLIED AT POINT A.</li> <li>2. COMPUTE SLOPE <math>\theta_2</math> ABOVE GROUND AS A FUNCTION OF M FROM CHARACTERISTICS OF SUPERSTRUCTURE.</li> <li>3. COMPUTE SLOPE <math>\theta_1</math> FROM SLOPE COEFFICIENTS OF FIGURE 13 AS FOLLOWS: <math display="block">\theta_1 = F_\theta \left(\frac{PT^2}{EI}\right) + F_\theta \left(\frac{MT}{EI}\right)</math></li> <li>4. EQUATE <math>\theta_1 = \theta_2</math> AND SOLVE FOR VALUE OF M.</li> <li>5. KNOWING VALUES OF P AND M, SOLVE FOR DEFLECTION, SHEAR, AND MOMENT AS IN CASE I.</li> </ol> <p>NOTE: IF GROUND SURFACE AT PILE LOCATION IS INCLINED, LOAD P TAKEN BY EACH PILE IS PROPORTIONAL TO <math>I/H_0^3</math>.</p>

FIGURE 10  
Design Procedure for Laterally Loaded Piles

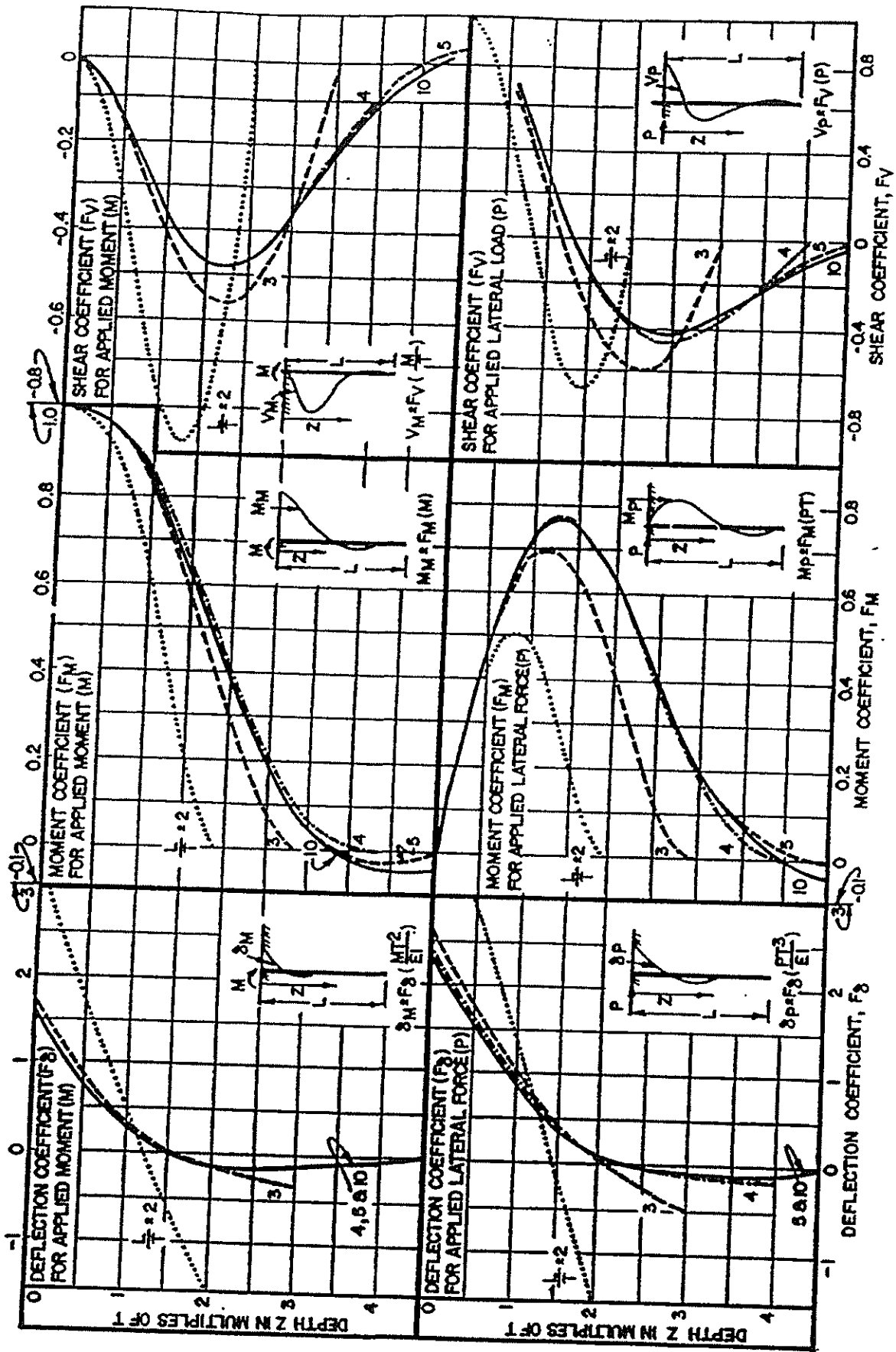


FIGURE 11  
 Influence Values for Pile with Applied Lateral Load and Moment  
 (Case I. Flexible Cap or Hinged End Condition)

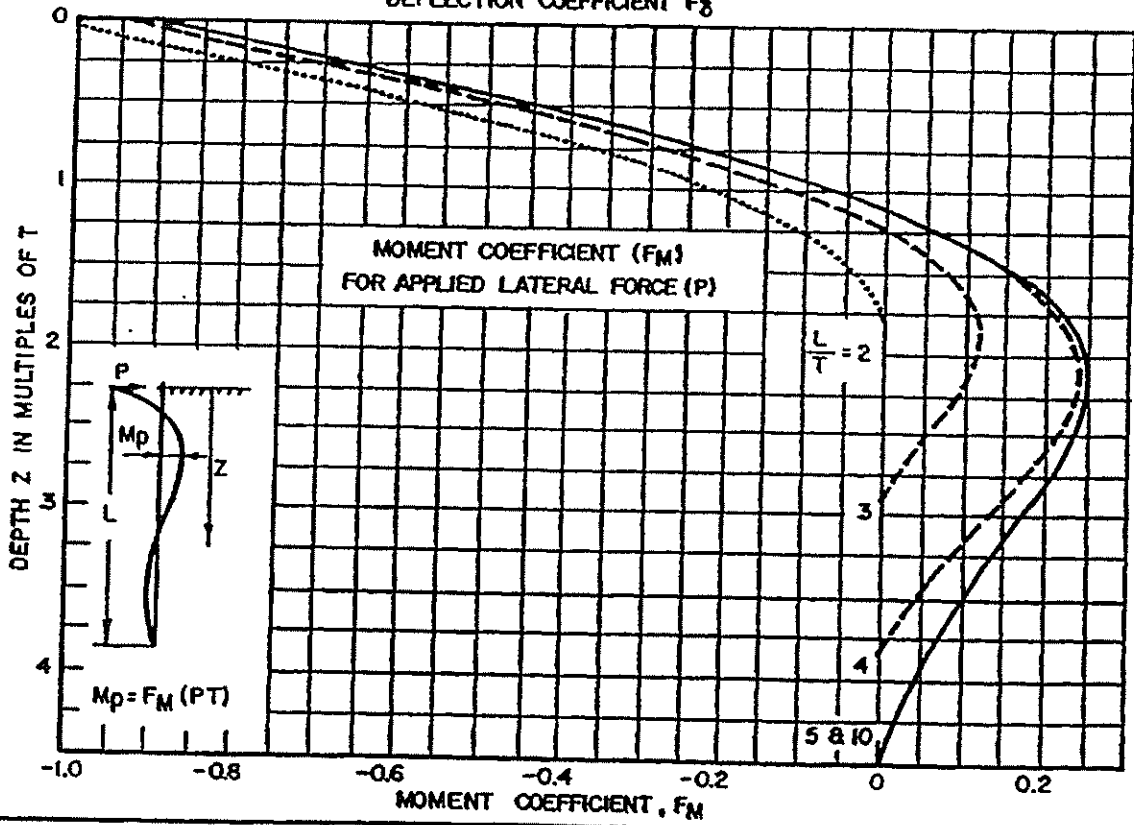
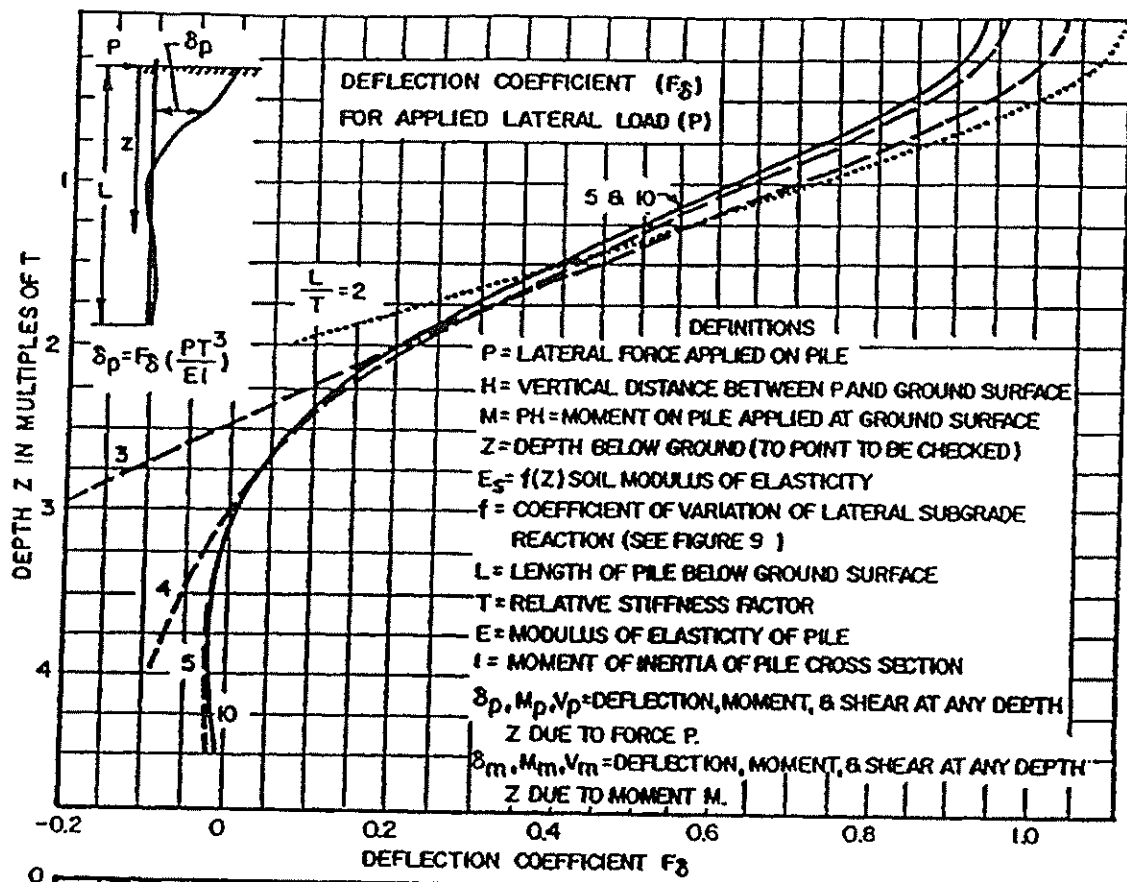


FIGURE 12  
 Influence Values for Laterally Loaded Pile  
 (Case II. Fixed Against Rotation at Ground Surface)  
 7.2-239

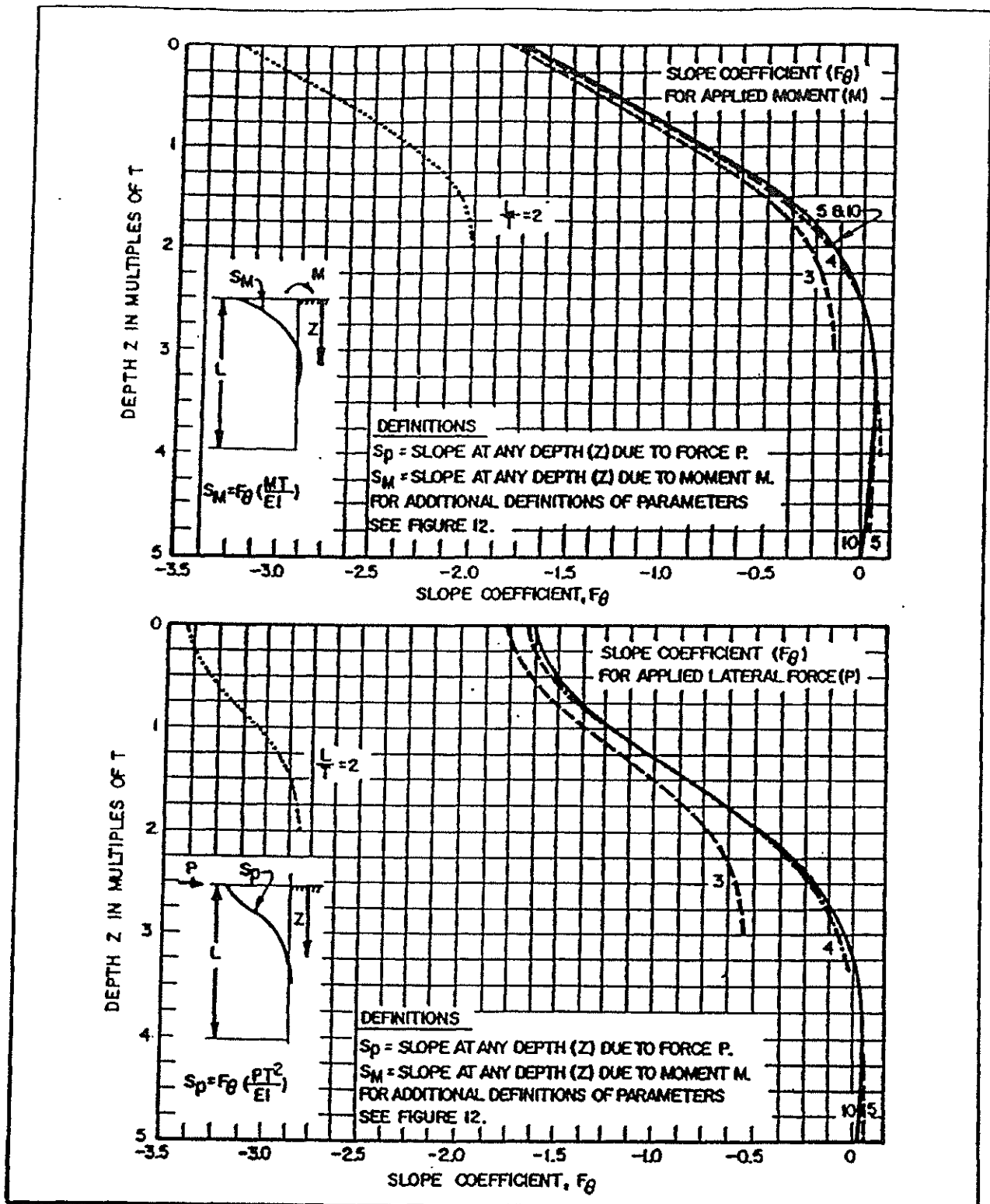


FIGURE 13  
 Slope Coefficient for Pile with Lateral Load or Moment

Case II. Pile with rigid cap fixed against rotation at ground surface. Thrust is applied at the top, which must maintain a vertical tangent. Obtain deflection and moment from influence values of Figure 12.

Case III. Pile with rigid cap above ground surface. Rotation of pile top depends on combined effect of superstructure and resistance below ground. Express rotation as a function of the influence values of Figure 13 and determine moment at pile top. Knowing thrust and moment applied at pile top, obtain total deflection, moment and shear in the pile by algebraic sum of the separate effects from Figure 11.

### 3. CYCLIC LOADS.

Lateral subgrade coefficient values decrease to about 25% the initial value due to cyclic loading for soft/loose soils and to about 50% the initial value for stiff/dense soils.

4. LONG-TERM LOADING. Long-term loading will increase pile deflection corresponding to a decrease in lateral subgrade reaction. To approximate this condition reduce the subgrade reaction values to 25% to 50% of their initial value for stiff clays, to 20% to 30% for soft clays, and to 80% to 90% for sands.

5. ULTIMATE LOAD CAPACITY - SINGLE PILES. A laterally loaded pile can fail by exceeding the strength of the surrounding soil or by exceeding the bending moment capacity of the pile resulting in a structural failure. Several methods are available for estimating the ultimate load capacity.

The method presented in Reference 33, Lateral Resistance of Piles in Cohesive Soils, by Broms, provides a simple procedure for estimating ultimate lateral capacity of piles.

6. GROUP ACTION. Group action should be considered when the pile spacing in the direction of loading is less than 6 to 8 pile diameters. Group action can be evaluated by reducing the effective coefficient of lateral subgrade reaction in the direction of loading by a reduction factor R (Reference 9) as follows:

File Spacing in Direction of Loading D = Pile Diameter	Subgrade Reaction Reduction Factor R
8D	1.00
6D	0.70
4D	0.40
3D	0.25



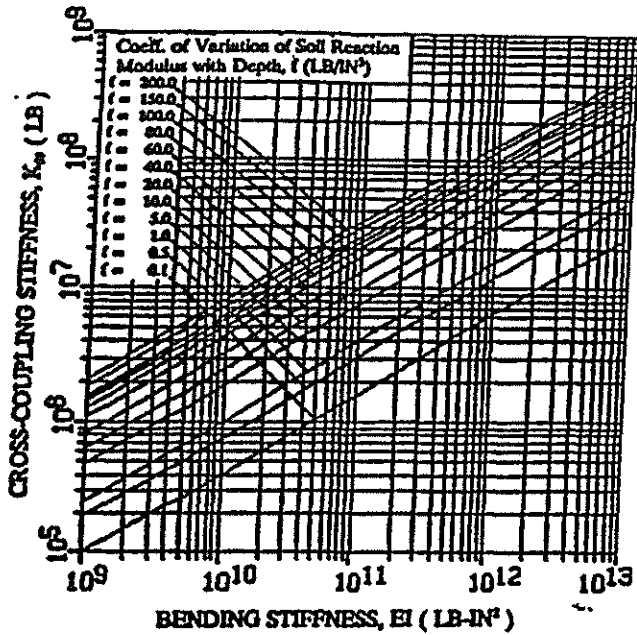


Figure 9. Pile Cross-Coupling Stiffness,  $K_{40}$

The authors. This recommendation and results of the correlation for clay are shown in Figure 11. Only the upper five lameters of soils (soil type and ground water) need to be considered in usage of the presented design charts.

**Limitations of Approach.** There are several simplifying assumptions in the presented approach. The coefficient  $f$  is not an intrinsic soil parameter. The recommendations for  $f$  presented in Figures 9 and 11 are appropriate for piles in typical highway bridge foundations (i.e. smaller piles). Furthermore, the embedment effect has not been taken into account in the procedure. Therefore the recommendations are conservative and appropriate for shallow embedment conditions (say less than 10 feet or 1.5 m).

Although correlations for the coefficient  $f$  can be conducted for other conditions (e.g. larger piles and bigger embedment depths), the additional complexity negates the merits of the use of simplified linear elastic solutions. For such cases, computer solutions, which can readily accommodate nonlinear effects and more general boundary conditions, are recommended.

**Comparison to Caltrans Practice.** The above procedure can be compared to the practice adopted by Caltrans. In Caltrans

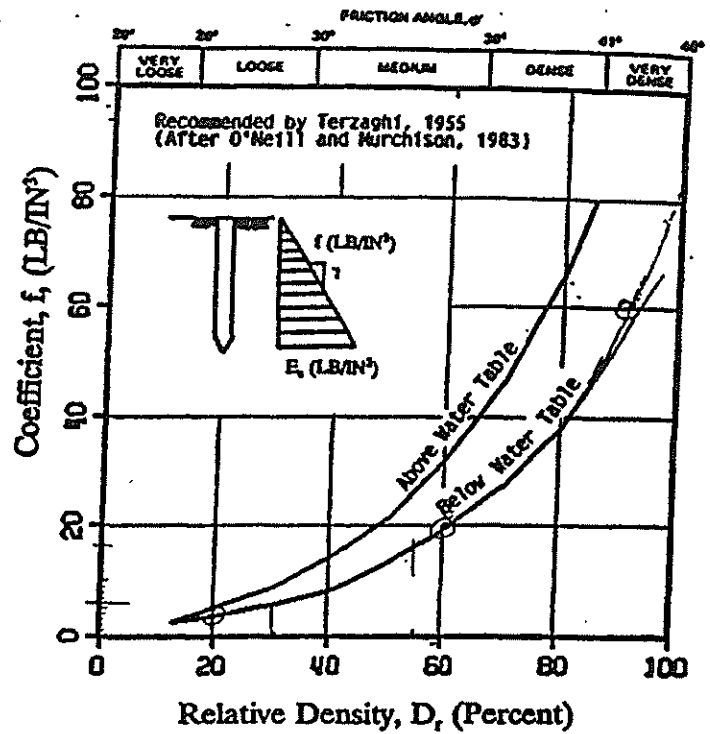


Figure 10. Recommendations for Coefficient  $f$  for Sands  
(Note:  $1 \text{ LB/IN}^3 = 0.27 \text{ N/cm}^3$ )

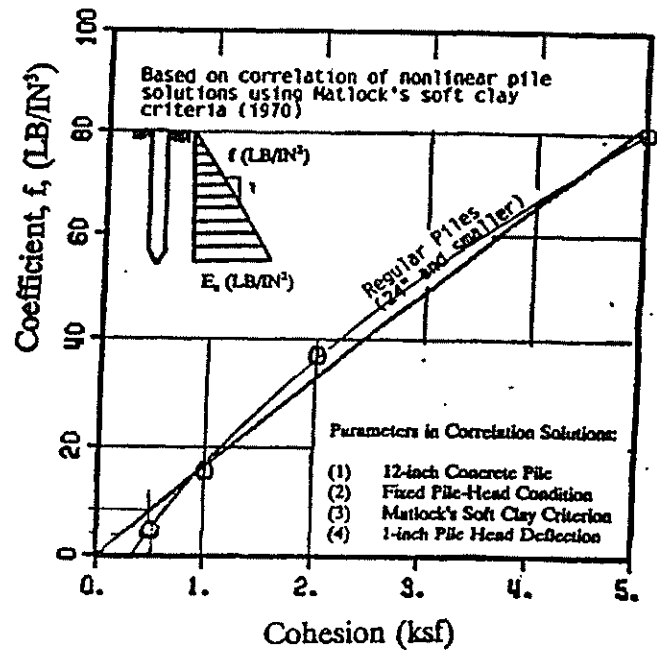


Figure 11. Recommendations of Coefficient  $f$  for Clays  
(Note:  $1 \text{ LB/IN}^3 = 0.27 \text{ N/cm}^3$ )



November 29, 2017

Ms. Corey Andrews  
City of Solana Beach  
635 South Highway 101  
Solana Beach, California 92075-2215

Subject: Geotechnical Review of Proposed Project  
Scott and Lisa Harris  
601 West Circle Drive  
Solana Beach, California

References:

1. "Geotechnical Investigation and Bluff Stability Study, 601 West Circle Drive, Solana Beach, CA", by TerraCosta Consulting Group, dated July 8, 2013
2. Plan Review and Updated Geotechnical Investigation, Harris Residence, 601 W. Circle Drive, Solana Beach, CA, by Geotechnical Exploration, dated May 24, 2017
3. Response to Geotechnical Reviewer Comments, Harris Residence, 601 West Circle Drive, Solana Beach, CA, by Geotechnical Exploration dated August 11, 2017
4. "Building Plans, Site Plans and Construction Plans for the Harris Addition", Prepared by DYJAK Design Build, dated October 25, 2017
5. Response to Geotechnical Reviewer Comments, Harris Residence, 601 W. Circle Drive, Solana Beach, CA, by Geotechnical Exploration, dated October 27, 2017

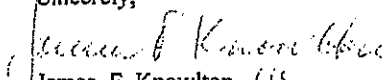
Dear Ms. Andrews:

In accordance with your request I have reviewed the referenced document for conformance to the requirements of the City of Solana Beach Municipal Code (SBMC), the recently adopted City of Solana Beach LCP/LUP and generally accepted standards of care for the preparation of geotechnical reports for shoreline stabilization projects in the State of California, County of San Diego and the City of Solana Beach. I have also visited the subject site several times and have had meetings with Solana Beach staff regarding my findings.

Based upon our review, from a geotechnical viewpoint, it appears that the geotechnical report(s) and site plan have adequately addressed all of my issues set forth in my review letter(s), dated June 29, 2017 and September 15, 2017 and therefore meet all of the requirements of the City of Solana Beach Municipal Code and the requirements of the City of Solana Beach LCP/LUP.

If you have any questions, please do not hesitate to call.

Sincerely,

  
James F. Knowlton  
RCE 55754 CEG 1045

3 0 6 0  
INDUSTRY ST  
SUITE 105  
OCEANSIDE  
CA 92054  
TEL: 760.721.5488  
FAX: 760.721.5539



# STAFF REPORT CITY OF SOLANA BEACH

**TO:** Honorable Mayor and City Councilmembers  
**FROM:** Gregory Wade, City Manager  
**MEETING DATE:** February 14, 2018  
**ORIGINATING DEPT:** Finance  
**SUBJECT:** **Resolution No. 2018-015 – City Council Consideration of Approving the Adoption of Mid-Year Budget Adjustments for Fiscal Year 2017/18**

---

## **BACKGROUND:**

During the course of any year, as new budgetary information becomes available, Staff presents that information to the Council for consideration when adjustments are recommended to the Adopted Budget.

This item is before the City Council for consideration of Resolution No. 2018-015 (Attachment 1) approving the adoption of mid-year budget adjustments for Fiscal Year (FY) 2017/18.

## **DISCUSSION:**

The City of Solana Beach's (City) Operating Budget Policies state that total expenditures of a particular fund may not exceed that which is appropriated by the City Council without a budget amendment. In addition, Section 3.08.040 of the Solana Beach Municipal Code limits the purchases by departments within the total departmental budget appropriations.

Staff is recommending that the City Council authorize the City Treasurer to amend the FY 2017/18 Adopted Budget for certain revenue and expenditure appropriations. The specific amendments to the FY 2017/18 Adopted Budget are discussed below in detail and categorized by General Fund and other funds.

## **General Fund Amendments**

### **General Fund – Revenues**

Staff analyzed revenues received by the City through December 2017. As part of the analysis, a comparison of revenues received against the annual budget for the first six months of this fiscal year was made as compared to last fiscal year. Any variance between the two years that was greater than 10% was analyzed in detail. In a few cases, budget adjustments are being recommended based on other separate analyses.

CITY COUNCIL ACTION:

---

---

## General Fund Appropriations – Revenues

- Property Taxes  
Revenues for property taxes are recommended to be increased by \$95,000 from \$7,297,000 to \$7,392,000 for current property taxes. This recommendation is based on an analysis done of the receivables posted by the County of San Diego for property taxes along with actual collection rates for the City over the past three years.
- Building Permits  
Each year, the City tracks its revenue collection rates at different mid-points during the fiscal year and estimates projected revenue based on a rolling four-year average of those collection rates.  
  
For Building Permits revenue, actual collection rates through December 31, 2017 were higher than the four year average collection rate at mid-year and Staff is proposing a budget increase to this revenue category of \$50,000 based on this analysis. This adjustment would increase Building Permits budgeted revenue from \$204,450 to \$254,450
- Motor Vehicle In Lieu  
The Adopted Budget appropriated \$1,510,000 for Motor Vehicle in Lieu revenue and the City has been notified by the County of San Diego that our actual revenue would be \$1,547,100. Staff is recommending an increase in this revenue category by \$37,100 to reflect this increase in anticipated Motor Vehicle in Lieu revenue.
- Community Grant  
Staff is recommending an increase in this revenue category by \$15,000 due to Community Grant funds committed to the City in this amount by Santa Fe Christian High School.
- Reimbursed Costs Revenue  
New street banners were made for the Breeder's Cup event at a cost of \$12,968, and the Breeder's Cup agreed to cover 75% of this cost. Staff is recommending an increase in this revenue category of \$9,700 which reflects the reimbursement received from the Breeder's Cup for the banners.

A summary of the recommended changes for General Fund revenues are listed in the table on the following page:

**Proposed Revenue Budget Adjustments  
 General Fund - Mid Year  
 Fiscal Year 2017/18**

<u>Account</u>	<u>Increases/ (Reductions)</u>
Property Tax-Current	\$ 95,000
Building Permits	50,000
Motor Vehicle in Lieu	37,100
Reimbursed Costs	9,700
Community Grants	15,000
<b>Total Adjustments</b>	<b><u>\$ 206,800</u></b>

General Fund Appropriations – Expenditures

Staff has also analyzed expenditures through December 2017 against budgeted expenditures. Based on this analysis, Staff is recommending increases to General Fund expenditure accounts totaling \$205,400.

The largest expenditure increase is \$52,000 for Planning Department temporary help. Temporary help is needed in the department due to: 1) the retirement of the Community Development Director at the end of December 2017 with a new director anticipated to be hired sometime near the end of March 2018; and 2) support to assist with the workload of the Associate Planner who is acting as the project leader for the implementation of the new permitting software, TRAKiT.

An increase of \$50,000 is also needed for Fire Department overtime costs. Expenditures through the end of December 2016 equal \$236,063 as compared to an annual budget of \$365,800. Costs are running ahead of the budget on a year-to-date basis and additional overtime coverage is necessary from vacancies and from worker compensation leave. Therefore, Staff is recommending an increase of \$50,000 from \$365,800 to \$415,800 to account for this increased cost.

A City entry sign has been installed at the entrance to the City on San Andreas Drive and the cost for the sign, which is a boulder with the "Solana Beach" lettering on it, cost \$8,600. The cost for the sign will be paid from the Public Arts Reserve in the General Fund and an appropriation to the Community Services budget is needed to reflect this transfer from the Reserve.

Salaries and benefits need to be reallocated from the City Manager's, Finance, and Engineering/Public Works budgets to reflect changes in costs and budget allocations with other General Fund budget units and non-General Fund budget units, such as the Self-Insurance and Sanitation funds. The changes in allocations reflect more closely what time

staff is devoting to the budget units. These changes will result in a net savings to the General Fund of \$3,800.

An appropriation to the Environmental Services budget is needed to increase the City's professional services contract with its stormwater consultant, MOE, Inc., by \$22,000. This increase is needed to implement Track 1 of the Trash Amendments that the City Council approved on August 23, 2017 and for conducting a special study in the Escondido Creek Hydrologic Area that is intended to address data gaps related to temporal flow and applicable pollutants at persistently flowing major Municipal Separate Storm Sewer System outfalls during dry weather conditions.

Staff is recommending an increase in building services costs of \$37,500 since building permits revenue is expected to increase by \$50,000 and 75% of this revenue category goes to EsGil, the City's on-call building plan check consultant

A summary of the recommend changes for General Fund expenditures are listed in the table on the following page:

**Proposed Expenditure Budget Adjustments  
 General Fund - Mid Year  
 Fiscal Year 2017/18**

<u>Account</u>	<u>Increases/ (Reductions)</u>
Fire Department overtime	
Overtime	\$ 50,000
Environmental	
Minor Equipment	6,600
Salary and Benefits	
City Manager	(4,900)
Human Resources	(1,500)
Finance	(5,600)
Engineering	3,100
Environmental	1,000
Street Maintenance	1,600
Community Services	1,500
Recreation	1,000
Community Services	
Entry Sign	8,600
Breeder Cup Banners	13,000
City Council	
Community Grants	18,000
Vehicle Maintenance	
Environmental	1,500
Professional Services	
Planning	52,000
Environmental	22,000
Building Services	37,500
<b>Total Adjustments</b>	<b>\$ 205,400</b>

Asset Replacement Fund

Staff is recommending the following appropriations be made to the Asset Replacement Fund:

Public Works vehicle equipment		\$	5,600	
Public Works power washer			10,000	
Fire Department station equipment			8,400	
City Clerk - Scanner			2,800	
Trakit Software			5,700	
Electronic Plan Review - software & hardware				
Planning/Building	\$	6,000		
Engineering		2,000		
Fire		2,000	10,000	
Total Asset Replacement Fund		\$	<u>42,500</u>	

The power washer will be used by Public Works Staff to better respond to graffiti removal and surface cleaning for both public areas as well as City Facilities. Under our current practices, when the scope of work exceeds our in-house capabilities, the Public Works Department needs to call for services which may take up to several days and would require contract processing efforts. With the proposed purchase, the City can save time and effort in performing these tasks.

The power washer would generate hot water to improve cleaning and would have a generator which would be mounted on the same trailer and also will be capable of reclaiming any water used for the operation.

Staff is recommending an appropriation of \$10,000 to purchase the power washer.

At the June 14, 2017 City Council meeting, Council approved a contract with Superior, LLC for the implementation and purchase of an annual subscription for the TRAKiT land management and permit streamlining software and the MyCommunity mobile app. The Council also added the capability for payment by electronic Check API (Check API) to the project scope.

The FY2018 Adopted Budget, also approved by Council at the June 14, 2017 City Council meeting, appropriated \$195,800 for the purchase based on the Superior contract before the addition of the Check API. With the addition of the Check API, the cost of the software increased by \$12,900.

The original contract also anticipated that the Planning Department's legacy database would be converted over to the TRAKiT software at a cost of \$7,200. After an evaluation was conducted by Staff and Superior, it was decided not to do the conversion since it would be



difficult to accomplish successfully. This portion of the contract is expected to be refunded to the City. With this expected savings of \$7,200, and the addition of Check API at \$12,900, Staff is recommending that the TRAKiT implementation project be increased by \$5,700.

Staff is also requesting funding for the purchase of new software and hardware that will allow Staff to convert from conventional paper-based plan review procedures to electronic plan review. Staff proposes installing shared review stations for each department that participates in development review (Planning, Engineering, Building, and Fire). Each review station would be equipped with a large computer monitor and Bluebeam Revu.

Bluebeam Revu is an end-to-end digital workflow and collaboration solution that allows PDF creation, editing, markup and collaboration technology. Staff has selected Bluebeam Revu because the software is also available as an add-on to TRAKiT, the City's permit tracking system that is currently undergoing configuration and implementation. Staff has opted to purchase stand-alone licensing ("seats") for Bluebeam Revu at this time with the intent of analyzing the integration with TRAKiT at a later date. The estimated cost for this first phase is \$10,000.

The software would allow Staff to share markups when necessary with applicants, which can significantly increase the effectiveness of plan review versus relying on written comments, phone calls or meetings to convey corrections. Bluebeam Revu also has the potential to expedite plan review cycles by allowing Staff to overlay submittals and immediately see changes made to plans between submittals. Additionally, the software provides dimension and area measuring tools and the ability to easily "slip sheet" and compile multiple files into one PDF. As Staff become accustomed to the software and reviewing electronic versus paper plans, the City can continue to implement new procedures for moving toward electronic plan review.

The benefits from electronic plan review also include a significant reduction in printing costs to applicants.

#### City CIP Fund

Policy 3.5 of the City's Local Coastal Plan (LCP) / Land Use Plan (LUP) requires the City to update the citywide Environmentally Sensitive Habitat Area (ESHA) maps every ten years to reflect current habitat and development boundaries and update information on rare, threatened or endangered species. The ESHA maps found in the current LCP/LUP were based on information gathered in 2008 and 2009 and created in 2010. The City would like to update the ESHA maps and submit them to the California Coastal Commission with the Local Implementation Plan. In order to update the maps, Merkel & Associates Inc. would update the citywide biological resource map based on current aerial and GIS data and then verified by a site visit to all the areas identified that potentially support ESHA. Staff is recommending that an appropriation be made to the Local Coastal Plan project in the City CIP fund for \$19,500 to pay for the estimated cost to update the ESHA maps.

Donations for Fletcher Cove Community Center (FCCC) donor tiles were received last fiscal year and enough tiles were sold to warrant a contract with Betsy Schulz to install the tiles.

Staff recommends an appropriation to the FCCC project in the City CIP fund of \$5,500 to cover the cost of the tile installation.

**Other Fund Amendments**

The following amendments to other funds are also recommended:

#	Fund Name	Description	Amount
120	Self Insurance	Salaries and Benefits	\$ 8,790
125	Workers Comp	Salaries and Benefits	971
211	Street Lighting	Salaries and Benefits	1,073
250	Coastal Visitors TOT	Community Grants	5,000
255	Camp Programs	Salaries and Benefits	485
283	Housing Fund	Professional Services (legal)-Hitzke	15,000
509	Sanitation	Salaries and Benefits	5,053
<b>Total Adjustments</b>			<b>\$ 36,372</b>

The Salaries and Benefits to be appropriated to the funds listed in the above table are the non-General Fund funds described in the “General Fund Appropriations – Expenditures” section of this Staff Report and the changes in the proposed allocations reflect more closely what time Staff is devoting to these funds.

**CEQA COMPLIANCE STATEMENT:**

Not a project as defined by CEQA

**FISCAL IMPACT:**

If Council approves Staff recommendations, the “General Fund – Adopted Budget Plus Changes” net surplus balance reported at each Council meeting would be updated as follows:

GENERAL FUND - ADOPTED BUDGET PLUS CHANGES					
As of January 24, 2018 (Proposed)					
Action	Description	Revenues	Expenditures	Transfers from GF	Net Surplus
Reso 2017-195	Adopted Budget	17 611.600	(16.932 700)	(372.400) (1)	\$ 306 500
Reso 2017-122	Marine Safety MOU	-	(11.340)	-	295.160
Reso 2017-123	Salary and Comp Plan	-	(75.500)	-	219.660
Reso 2017-126	Miscellaneous MOU	-	(53.600)	-	166.060
Reso 2018-015	FY18 Mid-Year Budget Adjustments	206.800	(205.400)		<u>167.460</u>

The General Fund’s projected budget surplus for FY 2017/18 would then increase \$1,400 to \$167,460.

**WORK PLAN:**

Fiscal Sustainability

**OPTIONS:**

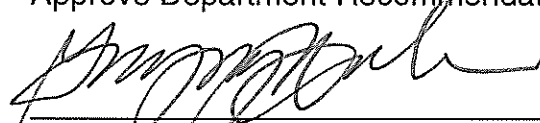
- Approve Staff Recommendation
- Deny Staff Recommendation

**DEPARTMENT RECOMMENDATION:**

Staff recommends the City Council adopt Resolution No. 2018-015 revising appropriations in the Fiscal Year 2017/18 Budget.

**CITY MANAGER'S RECOMMENDATION:**

Approve Department Recommendation.



---

Gregory Wade, City Manager

Attachments:

1. Resolution No. 2018-015

**RESOLUTION 2018-015**

**A RESOLUTION OF THE CITY COUNCIL OF THE CITY OF SOLANA BEACH, CALIFORNIA, REVISING APPROPRIATIONS IN THE FISCAL YEAR 2017/18 BUDGET AND AUTHORIZING THE CITY TREASURER TO AMEND THE BUDGET ACCORDINGLY**

**WHEREAS**, during the course of the fiscal year, new information becomes available to Staff which require adjustments to be made to the adopted budget; and

**WHEREAS**, Section 3.08.040 of the Solana Beach Municipal Code limits the purchases by departments within the total departmental budget appropriations; and

**WHEREAS**, the City's Operating Budget Policies state that total expenditures of a particular fund may not exceed that which is appropriated by the City Council, without a budget amendment; and

**WHEREAS**, the City Manager, in coordination with the Finance Manager, reviewed and analyzed the expenditures of the Fiscal Year 2017/18 Adopted Budget and recommend certain amendments be made to the General Fund as well as other funds.

**NOW THEREFORE BE IT RESOLVED**, by the City Council of the City of Solana Beach, California, does hereby resolve as follows:

1. That the above recitations are true and correct.
2. That the City Treasurer is authorized to amend appropriations in the 2017/18 fiscal year budget as further set forth in the attached Exhibit A.

//

//

//

**PASSED, APPROVED AND ADOPTED** by the City Council of the City of Solana Beach, California, this 14<sup>th</sup> day of February 2018, by the following vote:

AYES: Councilmembers –  
NOES: Councilmembers –  
ABSENT: Councilmembers –  
ABSTAIN: Councilmembers –

\_\_\_\_\_  
GINGER MARSHALL, Mayor

APPROVED AS TO FORM:

ATTEST:

\_\_\_\_\_  
JOHANNA N. CANLAS, City Attorney

\_\_\_\_\_  
ANGELA IVEY, City Clerk

**Exhibit A  
Resolution 2018-015**

**REVENUES**  
**General Fund**

**Account**

**Additions/  
Deletions**

Property Tax-Current	\$ 95,000
Building Permits	50,000
Motor Vehicle in Lieu	37,100
Reimbursed Costs	9,700
Community Grants	15,000
<b><i>Total General Fund</i></b>	<b><u>\$ 206,800</u></b>

**EXPENDITURES**  
**Fund 001 - General Fund**

City Council	Community Grants	\$ 18,000
City Manager	Salary and Benefits	(4,900)
Human Resources	Salary and Benefits	(1,500)
Finance	Salary and Benefits	(5,600)
Engineering	Salary and Benefits	3,100
Environmental Services	Salary and Benefits	1,000
Environmental Services	Vehicle Maintenance	1,500
Environmental Services	Professional Services	22,000
Environmental Services	Minor Equipment	6,600
Planning	Professional Services	52,000
Building Services	Professional Services	37,500
Fire Department	Overtime	50,000
Street Maintenance	Salary and Benefits	1,600
Community Services	Salary and Benefits	1,500
Community Services	Public Arts	8,600
Community Services	Professional Services	13,000
Recreation	Salary and Benefits	1,000
	<b><i>Total General Fund</i></b>	<b><u>\$ 205,400</u></b>

**Other Funds**

Asset Replacement	Equipment-Fire	10,400
	Equipment-Engineering/Public Works	12,000
	Vehicles-Public Works	5,600
	Equipment - Planning	11,700
	Equipment - City Clerk	2,800
	Self Insurance	Salaries and Benefits
Workers Comp	Salaries and Benefits	971
Street Lighting	Salaries and Benefits	1,073
Camp Programs	Salaries and Benefits	485
Sanitation	Salaries and Benefits	5,053
Housing Fund	Professional Services (Legal) Hitzke	15,000
City CIP	General Plan Update-Climate Action Plan	30,000
	FCCC CIP	5,500
Coastal Visitors/TOT	Community Grants	5,000

***Total Other Funds***

**\$ 114,372**

**\$ 319,772**